



# ZMOTION<sup>®</sup> Pyroelectric Sensors

## Product Specification

PS033601-1214





**Warning:** DO NOT USE THIS PRODUCT IN LIFE SUPPORT SYSTEMS.

---

### **LIFE SUPPORT POLICY**

ZILOG'S PRODUCTS ARE NOT AUTHORIZED FOR USE AS CRITICAL COMPONENTS IN LIFE SUPPORT DEVICES OR SYSTEMS WITHOUT THE EXPRESS PRIOR WRITTEN APPROVAL OF THE PRESIDENT AND GENERAL COUNSEL OF ZILOG CORPORATION.

### **As used herein**

Life support devices or systems are devices which (a) are intended for surgical implant into the body, or (b) support or sustain life and whose failure to perform when properly used in accordance with instructions for use provided in the labeling can be reasonably expected to result in a significant injury to the user. A critical component is any component in a life support device or system whose failure to perform can be reasonably expected to cause the failure of the life support device or system or to affect its safety or effectiveness.

### **Document Disclaimer**

©2014 Zilog, Inc All rights reserved. Information in this publication concerning the devices, applications, or technology described is intended to suggest possible uses and may be superseded. ZILOG, INC. DOES NOT ASSUME LIABILITY FOR OR PROVIDE A REPRESENTATION OF ACCURACY OF THE INFORMATION, DEVICES, OR TECHNOLOGY DESCRIBED IN THIS DOCUMENT. ZILOG ALSO DOES NOT ASSUME LIABILITY FOR INTELLECTUAL PROPERTY INFRINGEMENT RELATED IN ANY MANNER TO USE OF INFORMATION, DEVICES, OR TECHNOLOGY DESCRIBED HEREIN OR OTHERWISE. The information contained within this document has been verified according to the general principles of electrical and mechanical engineering.

ZMOTION and Z8 Encore! XP are trademarks or registered trademarks of Zilog, Inc. (An IXYS Company). All other product or service names are the property of their respective owners.

# Revision History

Each instance in the revision history table reflects a change to this document from its previous revision. For more details, refer to the corresponding pages or appropriate links provided in the table below.

<b>Date</b>	<b>Revision Level</b>	<b>Description</b>	<b>Page</b>
Dec 2014	01	Original issue, split into its own document from the former ZMOTION Lens and Pyroelectric Sensor Product Specification (PS0286), which is now titled ZMOTION Lenses Product Specification.	All

# Table of Contents

Revision History .....	iii
List of Figures .....	vi
List of Tables .....	vi
Overview .....	1
ZMOTION Pyroelectric Sensor Selection Guide .....	2
ZMOTION Pyroelectric Sensor Specifications .....	3
ZRE200GE Sensor Specification .....	3
Type of Sensor .....	3
Physical Configuration .....	3
Electrical Characteristics @ 25 ±5°C .....	3
Optical Characteristics .....	4
Environmental Requirements .....	4
RoHS Compliance .....	4
ZSBG323671 Sensor Specification .....	7
Type of Sensor .....	7
Physical Configuration .....	7
Electrical Characteristics @ 25 ±5°C .....	7
Optical Characteristics .....	8
Environmental Requirements .....	8
RoHS Compliance .....	8
Mechanical Drawings .....	9
ZSBG446671 Sensor Specification .....	11
Type of Sensor .....	11
Physical Configuration .....	11
Electrical Characteristics @ 25 ±5°C .....	11
Optical Characteristics .....	12
Environmental Requirements .....	12
RoHS Compliance .....	12
Mechanical Drawings .....	13
Precautions .....	15
Design Restrictions and Precautions .....	15
Usage Restrictions and Precautions .....	15
Assembly Restrictions and Precautions .....	15
Handling and Storage Restrictions and Precautions .....	16
Restrictions on Product Use .....	16



Related Documents ..... 17  
Customer Support ..... 18

## List of Figures

Figure 1.	ZRE200GE Mechanical Configuration	5
Figure 2.	ZRE200GE Circuit Configuration	6
Figure 3.	ZRE200GE Test Setup Block Diagram	6
Figure 4.	ZSBG323671 Mechanical Configuration	9
Figure 5.	ZSBG323671 Circuit Configuration	10
Figure 6.	ZSBG323671 Test Setup Block Diagram	10
Figure 7.	ZSBG446671 Mechanical Configuration	13
Figure 8.	ZSBG446671 Circuit Configuration	14
Figure 9.	ZSBG446671 Test Setup Block Diagram	14

## List of Tables

Table 1.	ZMOTION Pyroelectric Sensors	2
----------	------------------------------	---

# Overview

Zilog's ZMOTION Detection and Control and Intrusion Detection product families provide integrated and flexible solutions for Passive Infrared (PIR)-based motion detection applications. These product families are based on the ZMOTION MCU, a high-performance microcontroller featuring integrated PIR motion detection algorithms. Each family includes a selection of lenses and PIR sensors to fit a wide range of application requirements. Each lens and sensor combination is optimized for its intended application by configuration settings loaded into the ZMOTION MCU ensuring the best possible performance while significantly reducing development risk and minimizing time to market. Zilog's PIR Motion Detection Technology provides a dramatic improvement in both sensitivity and stability over traditional designs and is scalable to many market segments including Security/Intrusion Detection, Lighting Control, HVAC, Access Control, Vending, Display, Proximity, Power Management, Occupancy Sensing and many others.

This document provides the optical, electrical, and mechanical specifications for the Zilog-supported pyroelectric sensors included in the ZMOTION Family. Each supported lens and pyroelectric sensor combination is provided with an associated configuration file for the ZMOTION MCU. For more information on configuration files for specific lens and sensor combinations, refer to WP0018 ZMOTION Detection Lens and Pyro Electric Sensor Configuration Guide. It is possible to use other lenses and pyroelectric sensors not directly supported by Zilog by developing the appropriate configuration settings based on one of the existing files.

All pyroelectric sensors listed in this document are available from Zilog or from their associated manufacturers. Because Zilog is regularly adding new sensor support to these ZMOTION product families, please obtain the latest version of this document from our website at [zillog.com/ZMOTION](http://zillog.com/ZMOTION).

# ZMOTION Pyroelectric Sensor Selection Guide

[Table 1](#) presents a short list of available pyroelectric sensors that support applications that employ ZMOTION Detection and Control and ZMOTION Intrusion Detection MCUs. Select your pyroelectric sensor from this table based on your intended application.

**Table 1. ZMOTION Pyroelectric Sensors**

Part Number	Description	Recommended Applications	Recommended PIR Lens Type(s)	Manufacturer and MFR Part Number
ZRE200GE	Basic dual-element sensor <ul style="list-style-type: none"> <li>• Two sensitive areas, 1.0mm x 2.0mm, spaced 1.0mm apart</li> <li>• Low cost</li> </ul>	Occupancy/Vacancy sensors <ul style="list-style-type: none"> <li>• HVAC/energy management sensors</li> <li>• Intrusion motion detectors</li> <li>• Smart appliances</li> </ul>	Narrow- to wide-angle wall-mount Fresnel lenses	Nippon Ceramic Co., Ltd. (Nicera) RE200GE
ZSBG323671	Premium dual-element sensor <ul style="list-style-type: none"> <li>• Two sensitive areas, 1.0mm x 2.3mm, spaced 1.0mm apart</li> <li>• Internal EMI protection</li> </ul>	Intrusion motion detectors <ul style="list-style-type: none"> <li>• Occupancy/Vacancy sensors</li> <li>• HVAC/energy management sensors</li> <li>• Smart appliances</li> </ul>	Narrow- to wide-angle wall-mount Fresnel lenses	Nippon Ceramic Co., Ltd. (Nicera) SBG323-671
ZSBG446671	Premium quad-element sensor <ul style="list-style-type: none"> <li>• Four sensitive areas, 1.0mm x 1.0mm, spaced 1.0mm apart</li> <li>• Symmetrical sensor organization, optimized for ceiling-mount applications</li> <li>• Internal EMI protection</li> </ul>	Occupancy/Vacancy sensors <ul style="list-style-type: none"> <li>• HVAC/energy management sensors</li> <li>• Intrusion motion detectors</li> </ul>	Circular ceiling-mounted Fresnel lenses	Nippon Ceramic Co., Ltd. (Nicera) SBG446-671



# ZMOTION Pyroelectric Sensor Specifications

This chapter presents specifications for the pyroelectric sensors selected for the ZMOTION family of products. To see the specifications for lenses used in Zilog's ZMOTION Detection and Control and Intrusion Detection applications, refer to the [ZMOTION Lenses Specification \(PS0286\)](#).

## ZRE200GE Sensor Specification

This section describes the specifications for the ZRE200GE passive infrared pyroelectric sensor.

### Type of Sensor

Balanced differential (series-opposed type.)

### Physical Configuration

Package	TO-5 nickel-plated metal can with dimensions; see Side View, <a href="#">Figure 1</a> on page 5.
Element geometry	Two sensitive areas 2.0mm long, 1.0mm wide and spaced 1.0mm apart.
Element orientation	See Top View, <a href="#">Figure 1</a> on page 5.
Lead configuration	See Side and Base views, <a href="#">Figure 1</a> on page 5.

### Electrical Characteristics @ 25 ±5°C

Circuit configuration	Three-terminal sensor with source follower; see <a href="#">Figure 2</a> on page 6.
Operating voltage	3–10V DC ( $R_s = 47\text{K}\Omega$ ).
Source voltage	0.3–1.5V; $V_D = 5\text{V}$ , $R_s = 47\text{K}\Omega$ .
Signal output	Minimum 2.5V <sub>P-P</sub> ; typically 4.0V <sub>P-P</sub> . Signal output is measured at a chopper frequency of 1Hz when connected to an amplifier with a gain of 72.5dB at 1Hz and submitted to an infrared energy emission of 13microW/cm <sup>2</sup> from a 420K black body. See <a href="#">Figure 3</a> on page 6.

Noise output	Max. 250 mV <sub>P-P</sub> ; typically 90mV <sub>P-P</sub> . Noise output should be measured for 20 seconds when connected to an amplifier with a gain of 72.5dB at 1 Hz and shielded from infrared energy. See <a href="#">Figure 3</a> on page 6.
Balance output	Max. 15%. [ $BO /  SA+SB  \leq 0.15$ , in which: BO = Balance output SA = Signal output on Element A SB = Signal output on Element B  Balance output is measured at a chopper frequency of 1 Hz when connected to an amplifier with a gain of 72.5 dB at 1 Hz and submitted to an infrared energy emission of 13 microW/cm <sup>2</sup> from a 420K black body. See <a href="#">Figure 3</a> on page 6.
Frequency response	0.3Hz to 3.0Hz / ±10dB.

## Optical Characteristics

Field of view	138° from center of element on Axis X. 125° from center of element on Axis Y. See Field of View, Figure 1.
Filter substrate	Silicon.
Cut on (5 %T ABS)	5.0 ±0.5µm.
Transmission	≥ 70%; average 7–14µm.

## Environmental Requirements

Operating temperature	–30°C to +70°C.
Storage temperature	–40°C to +80°C.
Relative humidity	The sensor operates without an increase in noise output when continuously exposed to 90–95% RH at 30°C.
Hermetic seal	The sensor must be sealed to withstand a vacuum of 21.28kPa.

## RoHS Compliance

The ZRE200GE Sensor conforms to the RoHS directive in force at the date of issuance of this specification.

Figures 1 and 2 present mechanical drawings of the Nicera ZRE200GE pyroelectric sensor.

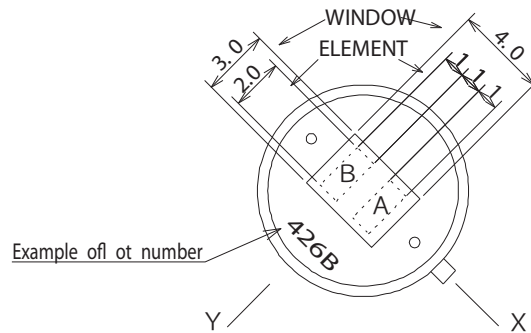
Field of view

(Figure 1-a)



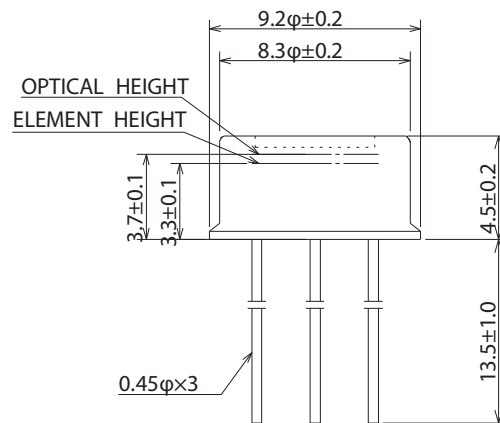
Top view

(Figure 1-b)



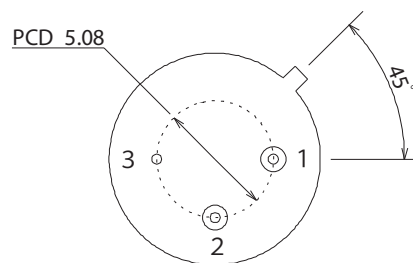
Side view

(Figure 1-c)



Base view

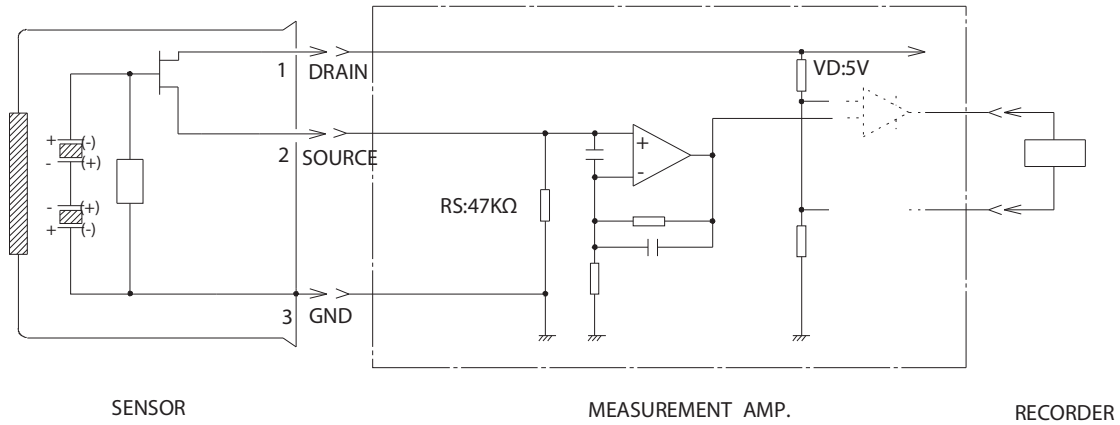
(Figure 1-d)



- 1: Drain
- 2: Source
- 3: Ground

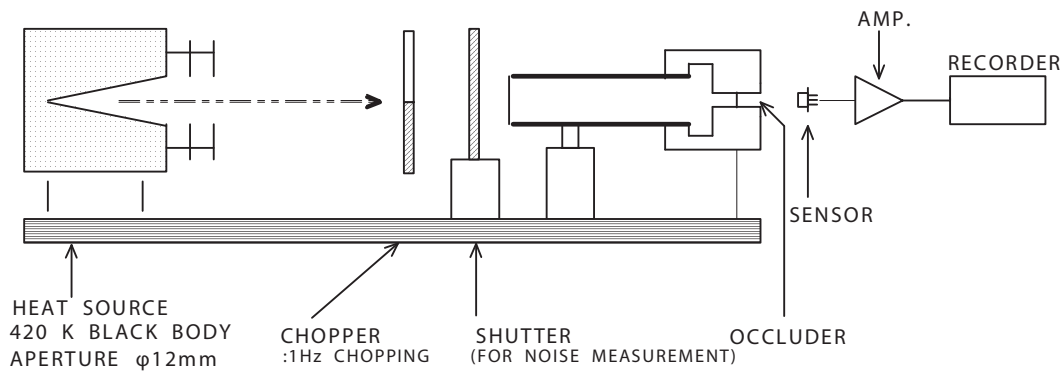
unit : mm

**Figure 1. ZRE200GE Mechanical Configuration**



Measurement Amp.: Non-inverted type, gain 72.5 dB at 1 Hz , 0.4 to 2.7 Hz / -3 dB

Figure 2. ZRE200GE Circuit Configuration



Occluder position

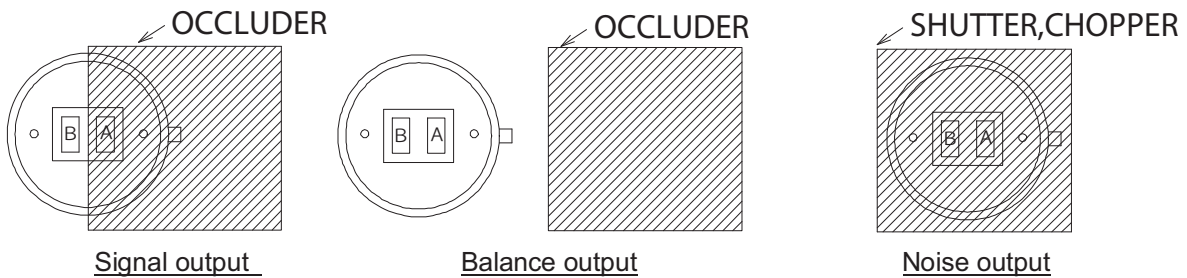


Figure 3. ZRE200GE Test Setup Block Diagram

## ZSBG323671 Sensor Specification

This section describes the specifications for the ZSBG323671 passive infrared pyroelectric sensor.

### Type of Sensor

Balanced differential (series-opposed type.)

### Physical Configuration

Package	TO-5 nickel-plated metal can with dimensions as shown in Side View, <a href="#">Figure 4</a> on page 9.
Element geometry	Two sensitive areas 2.3 mm long, 1.0 mm wide and spaced 1.0 mm apart.
Element orientation	See Top View, <a href="#">Figure 4</a> on page 9.
Lead configuration	See Side and Base views, <a href="#">Figure 4</a> on page 9.

### Electrical Characteristics @ 25 ±5°C

Circuit configuration	Three-terminal sensor with source follower; see <a href="#">Figure 5</a> on page 10.
Operating voltage	3–10 V DC (R <sub>s</sub> : 470 KΩ).
Source voltage	0.35–1.4 V (V <sub>D</sub> : 5 V vs. 470 KΩ).
Signal output	Minimum 2.6 V <sub>P-P</sub> ; typically 4.0 V <sub>P-P</sub> . Signal output is measured at a chopper frequency of 1 Hz when connected to an amplifier with a gain of 72.5 dB at 1 Hz and submitted to an infrared energy emission of 13 microW/cm <sup>2</sup> from a 420 K black body. See <a href="#">Figure 6</a> on page 10.
Noise output	Max. 250 mV <sub>P-P</sub> ; typically 90 mV <sub>P-P</sub> . Noise output should be measured for 20 seconds when connected to an amplifier with a gain of 72.5 dB at 1 Hz and shielded from infrared energy. See <a href="#">Figure 6</a> on page 10.

Balance output	Max. 10%. [ $BO /  SA+SB  \leq 0.10$ , in which: BO = balance output SA = signal output on Element A SB = signal output on Element B
----------------	--

Balance output is measured at a chopper frequency of 1 Hz when connected to an amplifier with a gain of 72.5 dB at 1 Hz and submitted to an infrared energy emission of 13 microW/cm<sup>2</sup> from a 420K black body. See [Figure 6](#) on page 10.

Frequency response	0.3Hz to 3.0Hz / $\pm 10$ dB.
--------------------	-------------------------------

## Optical Characteristics

Field of view	134° from center of element on Axis X. 120° from center of element on Axis Y. See Field of View, Figure 4.
Filter substrate	Silicon.
Cut on (5 %T ABS)	$5.5 \pm 0.5 \mu\text{m}$ .
Transmission	$\geq 70\%$ ; average 8–13 $\mu\text{m}$ .

## Environmental Requirements

Operating temperature	-30°C to +70°C.
Storage temperature	-40°C to +80°C.
Relative humidity	The sensor operate without an increase in noise output when continuously exposed to 90–95% RH at 30°C.
Hermetic seal	The sensor must be sealed to withstand a vacuum of 21.28kPa.

## RoHS Compliance

The ZSBG323671 Sensor conforms to the RoHS directive in force at the date of issuance of this specification.

## Mechanical Drawings

Figures 4 through 6 present mechanical drawings of the Nicera ZSBG323671 pyro sensor.

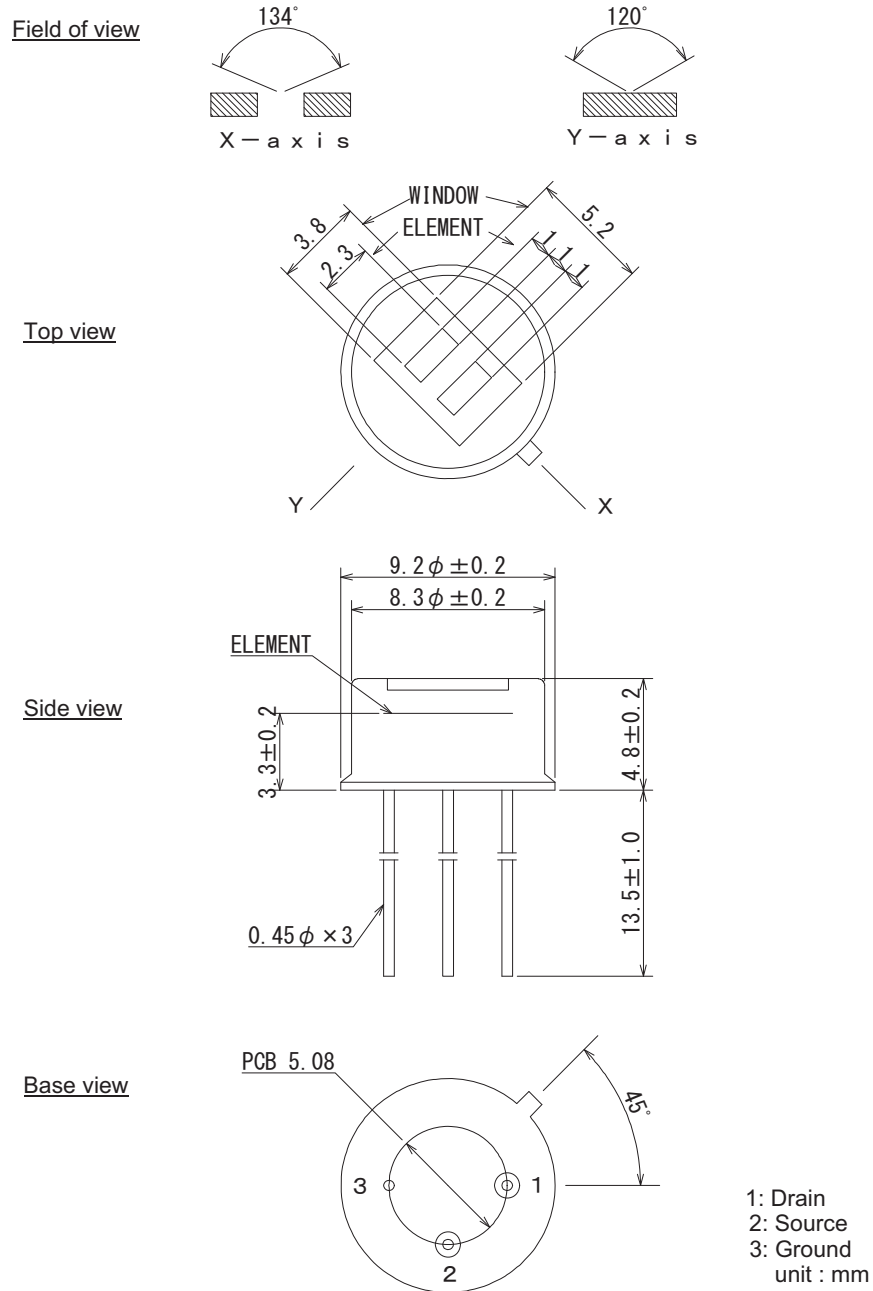
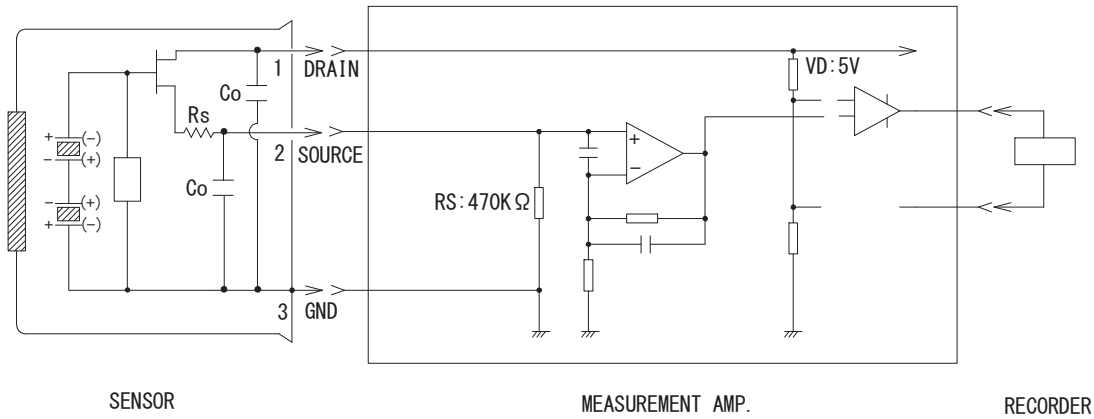
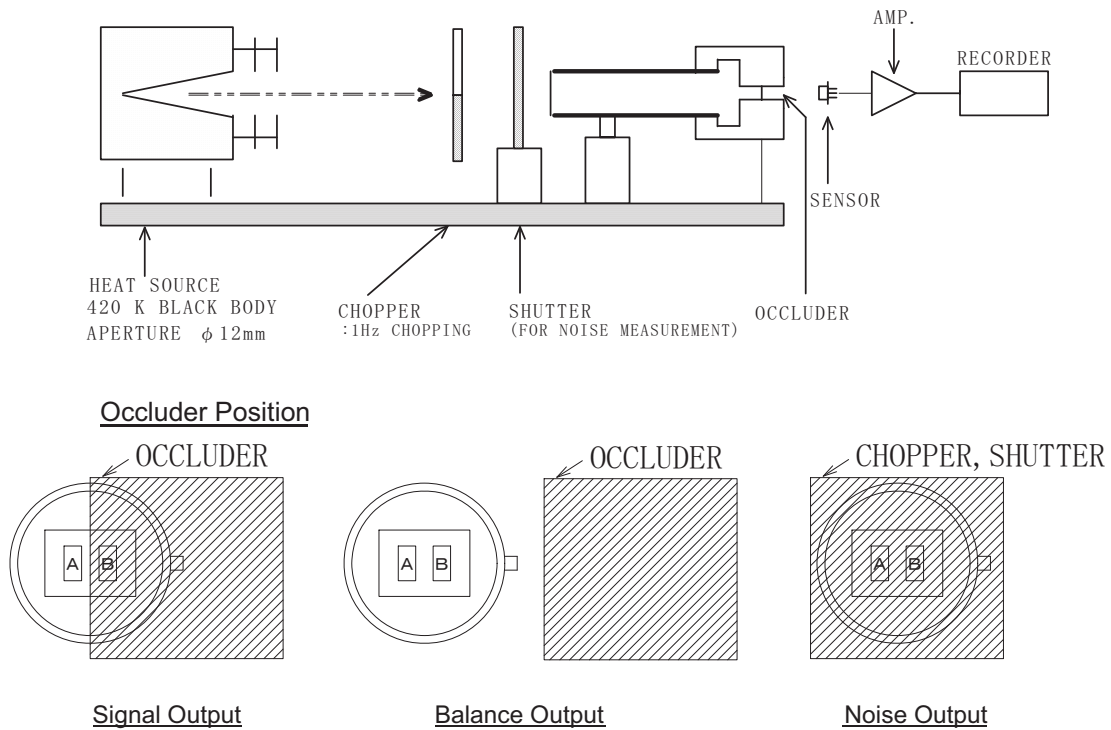


Figure 4. ZSBG323671 Mechanical Configuration



Measurement Amp.: Non-inverted type, gain 72.5 dB at 1 Hz, 0.4 to 2.7 Hz / -3 dB

**Figure 5. ZSBG323671 Circuit Configuration**



**Figure 6. ZSBG323671 Test Setup Block Diagram**



## ZSBG446671 Sensor Specification

This section describes the specifications for the Nicera ZSBG446671 passive infrared pyroelectric sensor.

### Type of Sensor

Balanced differential (series-opposed type.)

### Physical Configuration

Package	TO-5 nickel-plated metal can with dimensions as shown in Side View, <a href="#">Figure 7</a> on page 13.
Element geometry	Four sensitive areas 1.0 mm * 1.0mm and spaced 1.0mm apart.
Element orientation	See Top View, <a href="#">Figure 7</a> on page 13.
Lead configuration	See Side and Base views, <a href="#">Figure 7</a> on page 13.

### Electrical Characteristics @ 25 ±5°C

Circuit configuration	Three-terminal sensor with source follower; see <a href="#">Figure 8</a> on page 14.
Operating voltage	3–10V DC (Rs: 470KΩ).
Element polarity	Element A,C:(+) B,D:(-) or A,C:(-) B,D:(+).
Source voltage	0.35–1.4V (Vd: 5V vs. 470KΩ).
Signal output	Min. 4.5V <sub>p-p</sub> ; typically 6.5 V <sub>p-p</sub> . (S1, S2) signal output is measured at a chopper frequency of 1Hz when connected to an amplifier with a gain of 72.5dB at 1 Hz and submitted to an infrared energy emission of 13 microW/cm <sup>2</sup> from a 420K black body; see <a href="#">Figure 9</a> on page 14.
Noise output	Max. 250 mV <sub>P-P</sub> ; typically 90mV <sub>P-P</sub> . Noise output should be measured for 20 seconds when connected to an amplifier with a gain of 72.5dB at 1 Hz and shielded from infrared energy; see <a href="#">Figure 9</a> on page 14.

Balance output	Max. 15%. $\left[ \frac{ S1-S2 }{ S1+S2 } \leq 0.15 \right]$ S1 = signal output on Elements A + C S2 = signal output on Elements B + D
----------------	--

Balance output is measured at a chopper frequency of 1 Hz when connected to an amplifier with a gain of 72.5 dB at 1 Hz and submitted to an infrared energy emission of 13 microW/cm<sup>2</sup> from a 420K black body. See [Figure 9](#) on page 14.

Frequency response	0.3Hz to 3.0Hz / ±10dB.
--------------------	-------------------------

## Optical Characteristics

Field of view	132° from center of element on Axis X. 146° from center of element on 45°. See Field of View, Figure 4.
Filter substrate	Silicon.
Cut on (5 %T ABS)	5.5 ±0.5µm.
Transmission	≥ 70%; average 8–13µm.

## Environmental Requirements

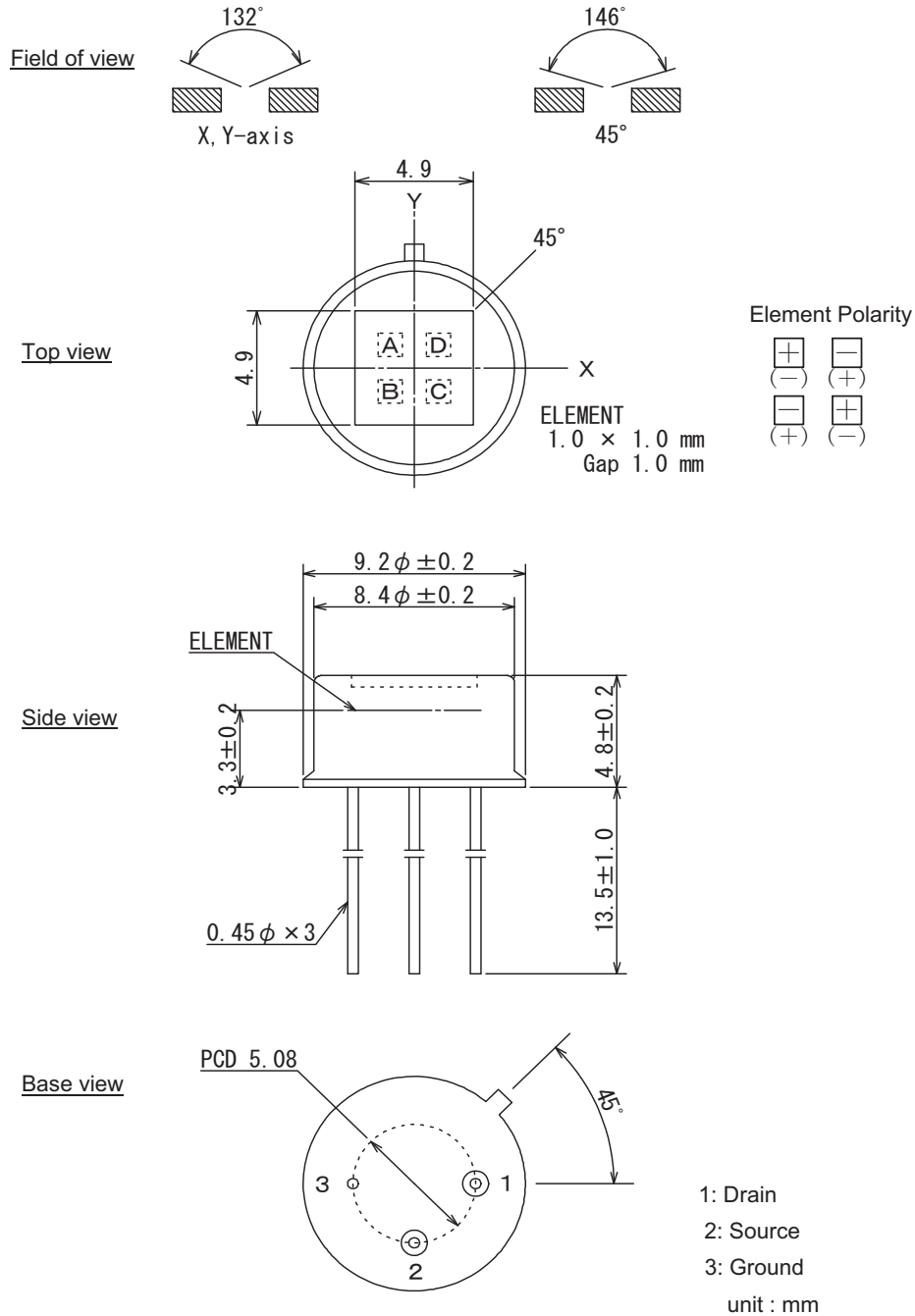
Operating temperature	–30°C to +70°C.
Storage temperature	–40°C to +80°C.
Relative humidity	The sensor operate without an increase in noise output when continuously exposed to 90–95% RH at 30°C.
Hermetic seal	The sensor must be sealed to withstand a vacuum of 21.28kPa.

## RoHS Compliance

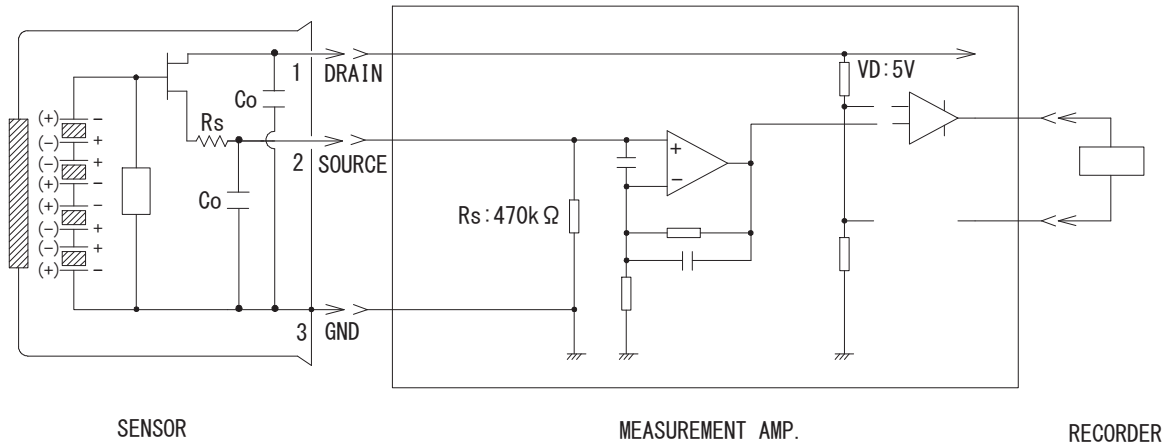
The ZSBG446671 Sensor conforms to the RoHS directive in force at the date of issuance of this specification.

## Mechanical Drawings

Figures 7 through 9 present mechanical drawings of the Nicera ZSBG446671 pyro sensor.

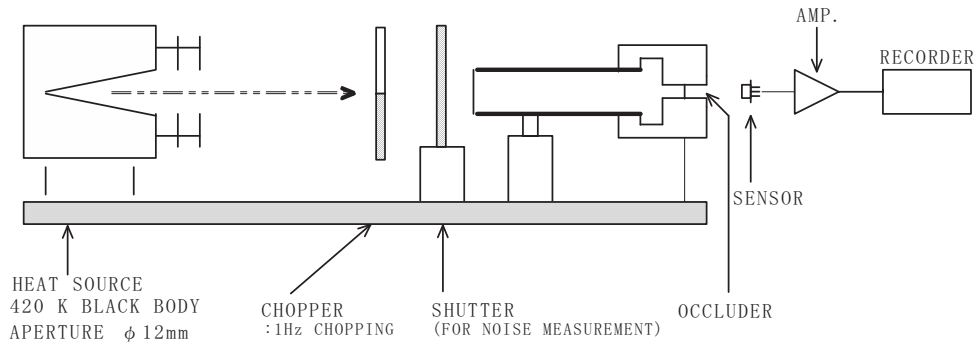


**Figure 7. ZSBG446671 Mechanical Configuration**

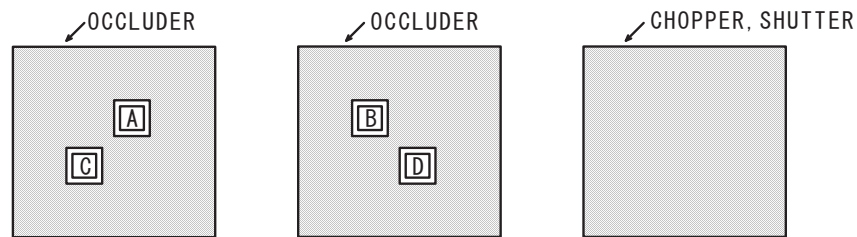


Measurement Amp.: Non-inverted type, gain 72.5 dB at 1 Hz , 0.4 to 2.7 Hz / -3 dB

**Figure 8. ZSBG446671 Circuit Configuration**



Occluder position



**Figure 9. ZSBG446671 Test Setup Block Diagram**

# Precautions

This chapter presents restrictions and precautions that apply to ZMOTION pyroelectric sensors.

## Design Restrictions and Precautions

This sensor is designed for indoor purposes in which secondary accidents due to operation failure or malfunctions can be anticipated; therefore, add appropriate fail-safe functionality to your design. If these sensors are intended for outdoor applications, be sure to apply suitable supplementary optical filters and design with drip-proof, anti-dew construction materials.

## Usage Restrictions and Precautions

To prevent sensor malfunctions, operational failure, or any deterioration of their characteristics, do not operate these ZMOTION sensors under the following, or similar, conditions:

- Rapid environmental temperature changes
- Strong shocks or vibrations
- In places where there are obstructing materials (glass, fog, etc.) through which infrared rays cannot pass within the detection area
- In fluids, corrosive gases, and sea breezes
- Under continual high-humidity atmospheric conditions
- When exposed to direct sunlight or automobile headlights
- When exposed to directly to forced-air currents from a heater or air conditioner

## Assembly Restrictions and Precautions

Soldering:

- Use soldering irons when soldering
- Avoid extended durations of heat on the sensors' pins, because excessive heat may cause deterioration of the sensor (e.g., durations beyond 5 seconds at 350°C)

Washing:

- Be sure to wash out all flux after soldering, because remaining solder materials may cause malfunctions

- Use a brush when washing; washing with an ultrasonic cleaner may cause operational failure

## Handling and Storage Restrictions and Precautions

To prevent sensor malfunctions, operational failure, appearance damage, or any deterioration of their characteristics, do not expose these sensors to the following, or similar, handling and storage conditions:

- Vibrations over extended periods
- Strong shocks
- Static electricity or strong electromagnetic waves
- High temperature and humidity over extended periods
- Corrosive gases or sea breezes
- Dirty and dusty environments that may contaminate the optical window

## Restrictions on Product Use

The products described in this document shall not be used or embedded into any downstream products for which their manufacture, use, and/or sale are prohibited under any applicable laws and regulations.

Sensor troubles resulting from misuse and/or inappropriate handling or storage are not the manufacturer's responsibility.

## Related Documents

Additional information about the ZMOTION Families of Motion Detection MCUs can be found in the following documents, which are available from the Zilog website at [www.zilog.com](http://www.zilog.com).

Document Number	Description
<a href="#">PB0225</a>	ZMOTION Detection and Control Family Product Brief
<a href="#">PB0230</a>	ZMOTION Intrusion Detection Product Brief
<a href="#">PS0228</a>	Z8 Encore! XP® F082A Series Product Specification
<a href="#">PS0285</a>	ZMOTION Detection and Control Family Product Specification
<a href="#">PS0286</a>	ZMOTION Lenses Product Specification
<a href="#">PS0288</a>	ZMOTION Intrusion Detection Product Specification
<a href="#">AN0307</a>	ZMOTION Detection Module Application Walkthrough
<a href="#">AN0309</a>	ZMOTION High Brightness White LED Lighting Application Note
<a href="#">WP0017</a>	A New PIR Motion Detection Architecture White Paper
<a href="#">WP0018</a>	ZMOTION Detection Lens and Pyro Sensor Configuration Guide
<b>Other ZMOTION Family Products</b>	
<a href="#">PB0244</a>	ZMOTION Detection Module II Product Brief
<a href="#">PS0305</a>	ZMOTION Detection Module II Product Specification

## ***Customer Support***

To share comments, get your technical questions answered, or report issues you may be experiencing with our products, please visit Zilog's Technical Support page at <http://support.zilog.com>.

To learn more about this product, find additional documentation, or to discover other facts about Zilog product offerings, please visit the Zilog Knowledge Base at <http://zilog.com/kb> or consider participating in the Zilog Forum at <http://zilog.com/forum>.

This publication is subject to replacement by a later edition. To determine whether a later edition exists, please visit the Zilog website at <http://www.zilog.com>.