

Features

- High Efficiency (Up to 85%)
- Active Power Factor Correction (Typical 0.92)
- Constant Output Current
- Waterproof (IP66)
- Dimming Control
- All-Round Protection: OVP, SCP, OLP
- Comply With UL8750 & EN61347 Safety Regulations (Pending)



Description

The EUC-025SxxxDS Series operate from a 90 ~ 305 Vac input range. These units will provide up to a 2080 mA of output current and a maximum output voltage of 72 V for 25 W maximum output power. They are designed to be highly efficient and highly reliable. Features include over voltage protection, short circuit protection and over load protection.

Models

Output Current	Input Voltage	Max. Output Voltage	Max. Output Power	Typical Efficiency (1)	Power Factor		Model Number With Dimming Control (2, 3)	Model Number Without Dimming Control (2, 3)
					110Vac	220Vac		
2080 mA	90 ~ 305 Vac	12 Vdc	25 W	80%	0.99	0.92	EUC-025S208DS	EUC-025S208PS
1750 mA	90 ~ 305 Vac	14 Vdc	25 W	81%	0.99	0.92	EUC-025S175DS	EUC-025S175PS
1400 mA	90 ~ 305 Vac	18 Vdc	25 W	82%	0.99	0.92	EUC-025S140DS	EUC-025S140PS
1050 mA	90 ~ 305 Vac	24 Vdc	25 W	83%	0.99	0.92	EUC-025S105DS	EUC-025S105PS
700 mA	90 ~ 305 Vac	36 Vdc	25 W	83%	0.99	0.92	EUC-025S070DS	EUC-025S070PS
620 mA	90 ~ 305 Vac	40 Vdc	25 W	83%	0.99	0.92	EUC-025S062DS	EUC-025S062PS
450 mA	90 ~ 305 Vac	56 Vdc	25 W	84%	0.99	0.92	EUC-025S045DS	EUC-025S045PS
350 mA	90 ~ 305 Vac	72 Vdc	25 W	85%	0.99	0.92	EUC-025S035DS	EUC-025S035PS

- Notes:** (1) Measured at full load and 220 Vac input.
 (2) The DS suffix may be changed to PS to omit the dimming function and remove the three wires associated with that function.
 (3) A suffix –xxx may be added to denote variations or modifications to the base product, where x can be any alphanumeric character or blank.

Input Specifications

Parameter	Min.	Typ.	Max.	Notes
Input Voltage	90 V	-	305 V	
Input Frequency	47Hz	-	63 Hz	
Input AC Current	-	-	0.32 A	Measured at full load and 100 Vac input.
	-	-	0.15 A	Measured at full load and 220 Vac input.
Inrush Current	-	-	20 A	At 230Vac input 25°C Cold Start .

Specifications are subject to changes without notice.

Output Specifications

Parameter	Min.	Typ.	Max.	Notes
Output Current Range				
$I_o = 2080 \text{ mA}$	1976 mA	-	2184 mA	
$I_o = 1750 \text{ mA}$	1663 mA	-	1838 mA	
$I_o = 1400 \text{ mA}$	1330 mA	-	1470 mA	
$I_o = 1050 \text{ mA}$	998 mA	-	1103 mA	
$I_o = 700 \text{ mA}$	665 mA	-	735 mA	
$I_o = 620 \text{ mA}$	589 mA	-	651 mA	
$I_o = 450 \text{ mA}$	428 mA	-	473 mA	
$I_o = 350 \text{ mA}$	333 mA	-	368 mA	
Output Voltage Range				
$I_o = 2080 \text{ mA}$	4 V	-	12 V	
$I_o = 1750 \text{ mA}$	5 V	-	14 V	
$I_o = 1400 \text{ mA}$	6 V	-	18 V	
$I_o = 1050 \text{ mA}$	8 V	-	24 V	
$I_o = 700 \text{ mA}$	12 V	-	36 V	
$I_o = 620 \text{ mA}$	13 V	-	40 V	
$I_o = 450 \text{ mA}$	19 V	-	56 V	
$I_o = 350 \text{ mA}$	24 V	-	72 V	
Ripple and Noise (pk-pk)	-	-	10% V_o	Measured by 20 MHz bandwidth oscilloscope and the output paralleled a 0.1 uF ceramic capacitor and a 10 uF electrolytic capacitor.
Line Regulation	-	-	2%	
Load Regulation	-	-	5%	
Turn-on Delay Time	-	1.7 S	2.0 S	Measured at 110Vac input.
	-	0.7 S	1.0 S	Measured at 220Vac input.
Output Overshoot / Undershoot	-	-	10%	When power on or off.

Note: All specifications are typical at 25 °C unless otherwise stated.

Protection Functions

Parameter	Min.	Typ.	Max.	Notes
Over Voltage Protection				
$I_o = 2080 \text{ mA}$	13 V	15 V	17 V	Hiccup mode. The power supply shall be self-recovery when the fault condition is removed.
$I_o = 1750 \text{ mA}$	16 V	18 V	20 V	
$I_o = 1400 \text{ mA}$	21 V	23 V	25 V	
$I_o = 1050 \text{ mA}$	30 V	32 V	34 V	
$I_o = 700 \text{ mA}$	46 V	48 V	50 V	
$I_o = 620 \text{ mA}$	48 V	50 V	52 V	
$I_o = 450 \text{ mA}$	71 V	73 V	75 V	
$I_o = 350 \text{ mA}$	92 V	94 V	96 V	
Over Load Protection	-	1.25 P_o	-	Hiccup mode. The power supply shall be self-recovery when the fault condition is removed.
Short Circuit Protection	No damage shall occur when any output operating in a short circuit condition. The power supply shall be self-recovery when the fault condition is removed.			

Specifications are subject to changes without notice.

General Specifications

Parameter	Min.	Typ.	Max.	Notes
Efficiency I _o = 2080 mA I _o = 1750 mA I _o = 1400 mA I _o = 1050 mA I _o = 700 mA I _o = 620 mA I _o = 450 mA I _o = 350 mA	78% 79% 80% 81% 81% 81% 82% 83%	79% 80% 81% 82% 82% 82% 83% 84%	- - - - - - - -	Measured at full load and 110 Vac input.
Efficiency I _o = 2080 mA I _o = 1750 mA I _o = 1400 mA I _o = 1050 mA I _o = 700 mA I _o = 620 mA I _o = 450 mA I _o = 350 mA	79% 80% 81% 82% 82% 82% 83% 84%	80% 81% 82% 83% 83% 83% 84% 85%	- - - - - - - -	Measured at full load and 220 Vac input.
No Load Power Dissipation	≤ 3 W			
MTBF	484,000 hours			For 2080 mA output model, measured at 110Vac input, 80%Load and 25°C ambient temperature (MIL-HDBK-217F).
Life Time	79,000 hours			For 2080 mA output model, measured at 110Vac input, 80%Load and 45°C ambient temperature
Dimensions Inches (L x W x H) Millimeters (L x W x H)	3.07 x 3.15 x 0.98 78 x 80 x 25			
Net Weight	-	200 g	-	

Note: All specifications are typical at 25 °C unless otherwise stated.

Environmental Specifications

Parameter	Min.	Typ.	Max.	Notes
Operating Temperature	-20 °C	-	+70 °C	Humidity: 10% RH to 100% RH
Storage Temperature	-40 °C	-	+85 °C	Humidity: 5% RH to 100% RH

Safety & EMC Compliance

Safety Category	Country	Standard
CUL	USA & Canada	UL8750 Compliance to UL1310 Class2 UL1012 UL935, CAN/CSA-C22.2 No. 0, CSA-C22.2 No. 107.1, CSA-C22.2 No. 250.0
CE	Europe	EN 61347-1, EN61347-2-13
EMI Standards		Notes
EN 55015		Conducted emission Test & Radiated emission Test with 6 dB margin

Specifications are subject to changes without notice.

EMS Standards	Notes
EN 61000-3-2	Harmonic current emissions
EN 61000-3-3	Voltage fluctuations & flicker
EN 61000-4-2	Electrostatic Discharge (ESD): 8 kV air discharge, 4 kV contact discharge
EN 61000-4-3	Radio-Frequency Electromagnetic Field Susceptibility Test-RS
EN 61000-4-4	Electrical Fast Transient / Burst-EFT
EN 61000-4-6	Conducted Radio Frequency Disturbances Test-CS
EN 61000-4-8	Power Frequency Magnetic Field Test
EN 61000-4-11	Voltage Dips
EN 61547	Electromagnetic Immunity Requirements Applies To Lighting Equipment

Derating Curve

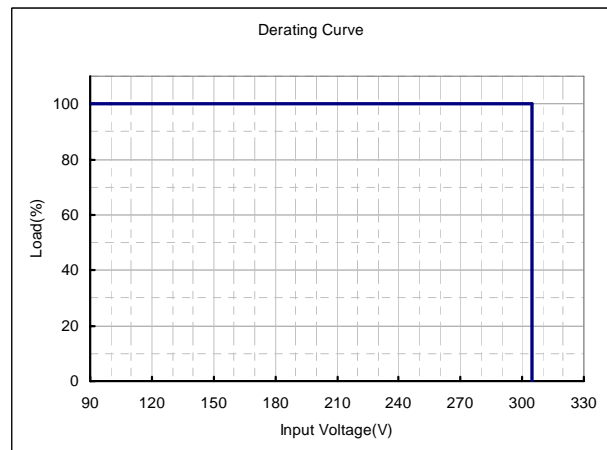
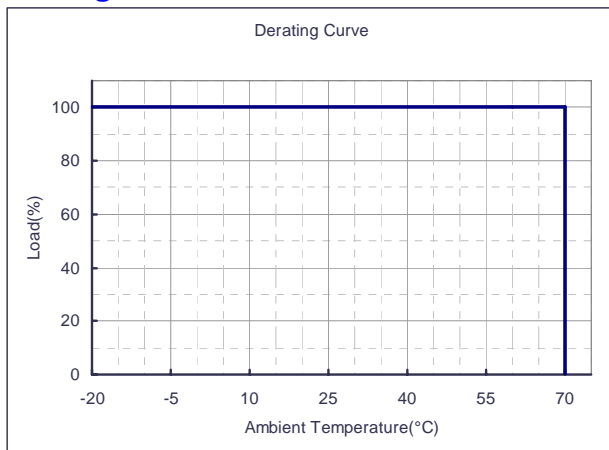

Mechanical Outline

EUC-025SxxxPS

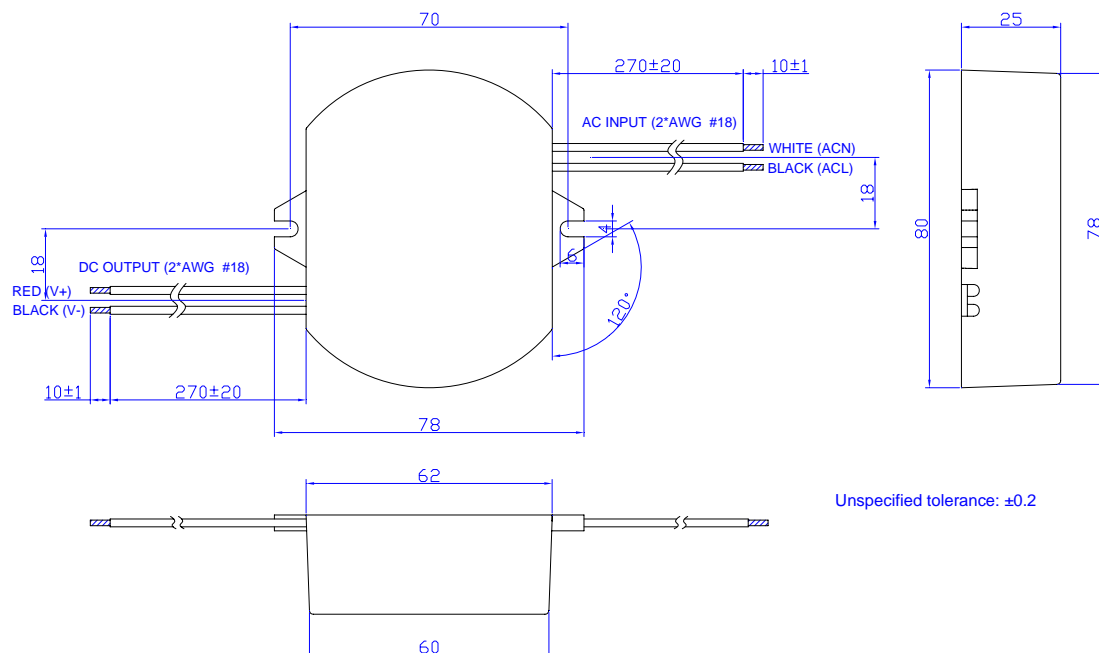

Specifications are subject to changes without notice.

EUC-025SxxxDS

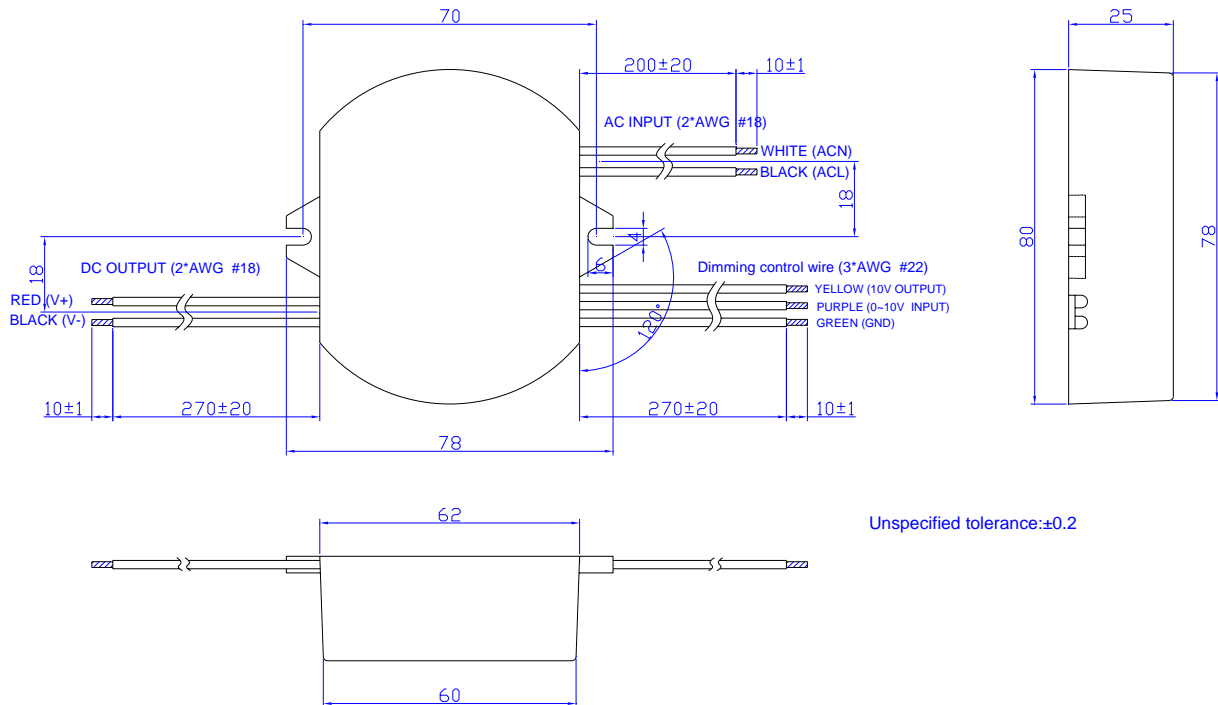

Dimming Control (On secondary side)

Parameter	Min.	Typ.	Max.	Notes
10V output voltage	9.8 V	10 V	10.2 V	
10V output source current	-10 mA	-	2 mA	
Absolute maximum voltage on the 0~10V input pin	-2 V	-	15 V	
Source current on 0~10V input pin	0 mA	-	1 mA	

The dimmer control may be operated from either a potentiometer or from an input signal of 0 – 10 Vdc. Two recommended implementations are provided below.

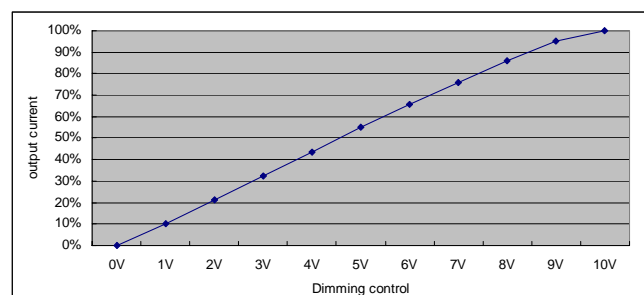
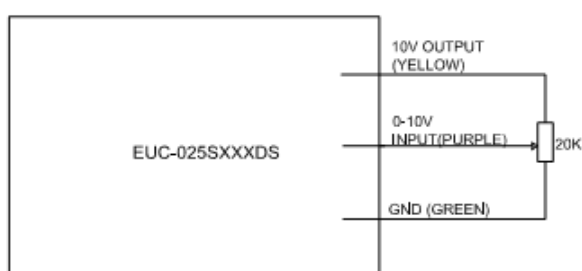

Implementation 1: Potentiometer Control

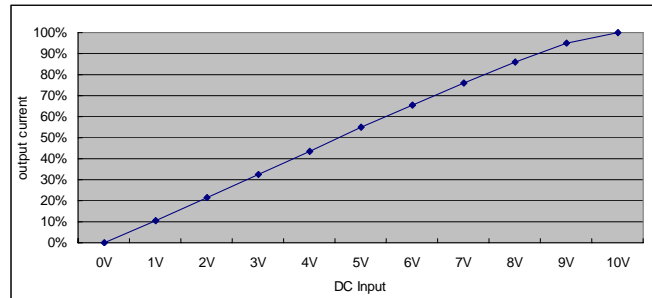
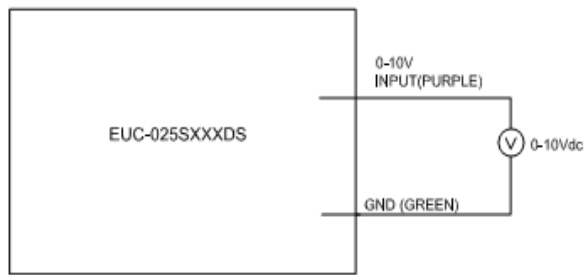

Implementation 2: DC input

Notes:

1. For the driver to operate properly, the load voltage must be maintained above the minimum voltage threshold (approx. 33% of the max. output voltage for any given model).
2. If the output voltage is maintained above 50% of the maximum output voltage, the dimmer control may be operated over the entire 0-10V range with output current varying from 100% down to practically 0%.
3. If the output voltage is maintained between 33-50% of the maximum output voltage, the dimmer control may be operated over 5-10V range with output current varying from 100% down to 50%. Dimming below 5V under these conditions is not guaranteed.

RoHS Compliance

Our products comply with the European Directive 2002/95/EC, calling for the elimination of lead and other hazardous substances from electronic products.

Revision History

Rev.	Description of Change	Changed Date	Note
V3.2	Change MTBF and Life Time	2009-09-02	
V3.3	Change Turn-on Delay Time	2009-09-11	

Specifications are subject to changes without notice.