

LV8806QAGEVB

LV8806QA Test Procedure for Quick Evaluation

Overview

This Evaluation board is designed to provide an easy and quick development platform for LV8806QA which is 3-phase BLDC motor driver for 5 V class.

Quick Evaluation

The evaluation board is programmed to work standalone without PC. The following operation allows the operation of most motors.

- Step 1. Connect a motor to the motor connector.
- Step 2. Connect PWM signal to the pin labeled 'PWM'.
- Step 3. Connect a power supply to the pin labeled 'VCC'.
- Step 4. Connect F/R pin to GND.
- Step 5. Turn on power supply and input 5 V to 'VCC'.
- Step 6. Turn on power supply and input 5 V to 'VDD'.
- Step 7. Input PWM signal.



ON Semiconductor®

www.onsemi.com

EVAL BOARD USER'S MANUAL

Test Procedure (for quick evaluation)

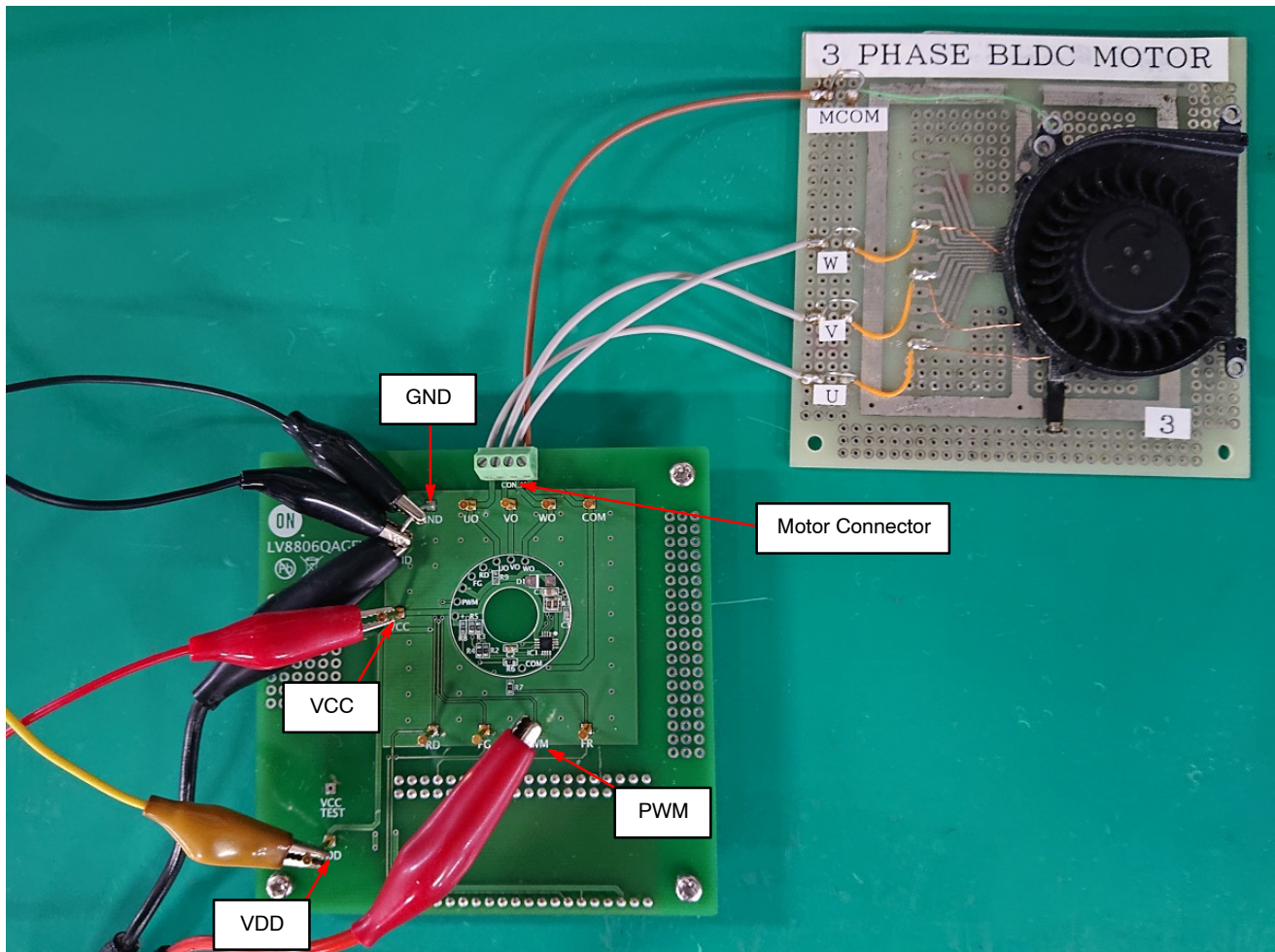

Figure 1. Example of Setting for Quick Evaluation

LV8806QAGEVB

HARDWARE DESCRIPTION

Table 1. PINS AND CONNECTORS IN LV8806QA EVALUATION BOARD

No.	Name	Description
1	Evaluation board	The evaluation board which works standalone (without the mother board)
2	Pin VCC	To input power supply voltage.
3	Connector	To connect to each motor coil edge (phase).
4	Pin UO/VO/WO/COM	To monitor each phase output of motor coil
5	Pin FR	To connect to GND or VCC to select motor rotation direction. GND: Forward rotation VCC: Revers rotation
6	Pin PWM	To input PWM (rotation speed control) signal. The signal level is: Frequency = 20 kHz, High level = 5 V, Low level = 0 V
7	Pin FG	To monitor FG (motor rotation pulse) signal output.
8	Pin RD	To monitor RD (motor rotation / stop) signal output.
9	Pin VDD	To bias pull-up resistors for FG / RD output.

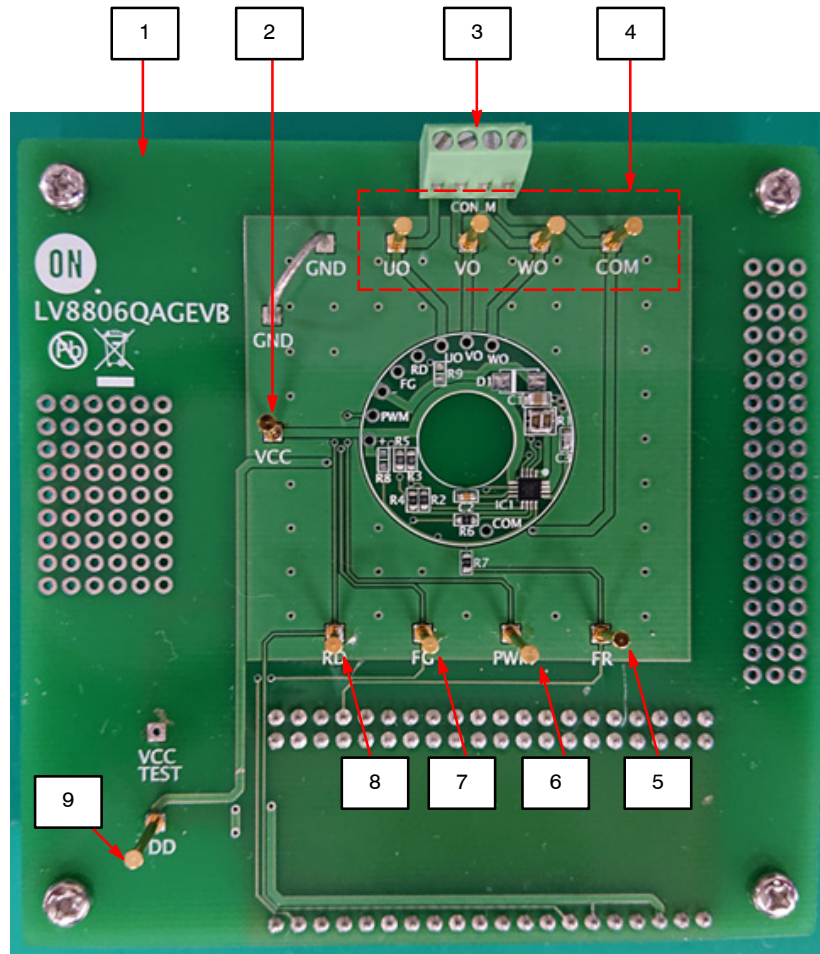

Figure 2. Top view of LV8806QA Evaluation Board

LV8806QAGEVB

APPLICATION DIAGRAM

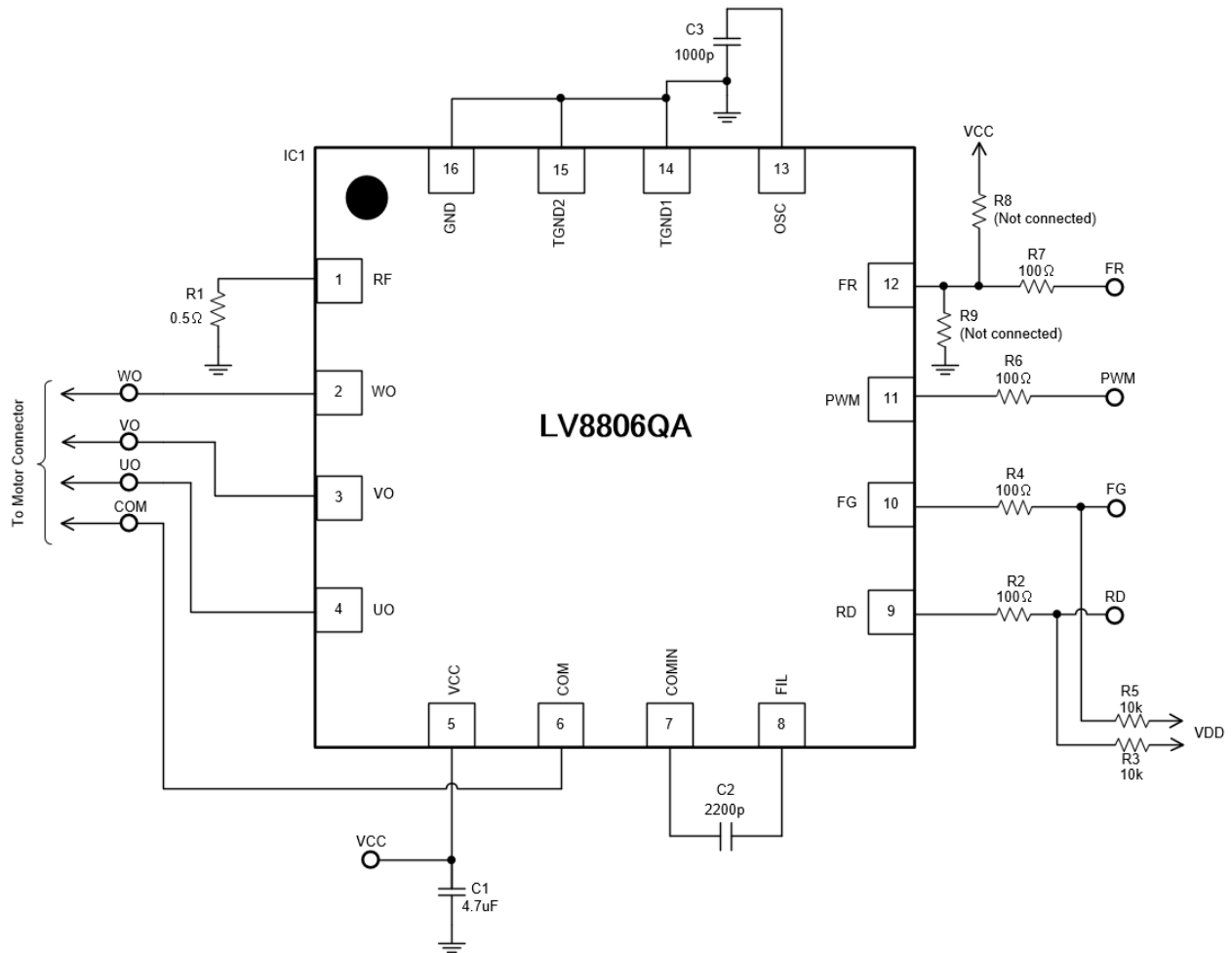

Figure 3. LV8806QA Evaluation Board Schematic

Table 2. COMPONENT LIST OF LV8806QA EVALUATION BOARD

No.	Description	Value
IC1	LV8806QA	(1 device)
C1	VCC bypass capacitor	4.7 μF
C2	Filter for output (U/V/W) signal	2,200 pF
C3	Capacitor for oscillation	1,000 pF
R1	Current sense resistor	0.5 Ω (1 Ω //2)
R2	Protection against external pin	100 Ω
R3	Pull-up resistor	10k Ω
R4	Protection against external pin	100 Ω
R5	Pull-up resistor	10k Ω
R6	Protection against external pin	100 Ω
R7	Protection against external pin	100 Ω
R8	Pull-up resistor	Not used
R9	Pull-down resistor	Not used

LV8806QAGEVB

WAVEFORMS

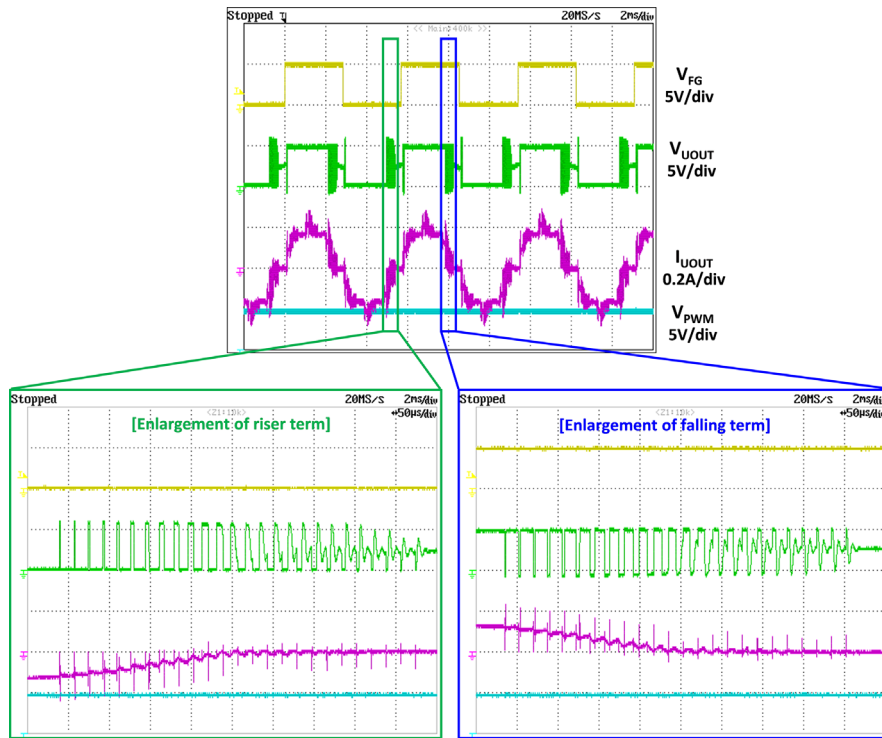

Figure 4. The Image of Waveforms of Example 1
(PWMIN Duty-cycle = 100%, VDD = 5 V)

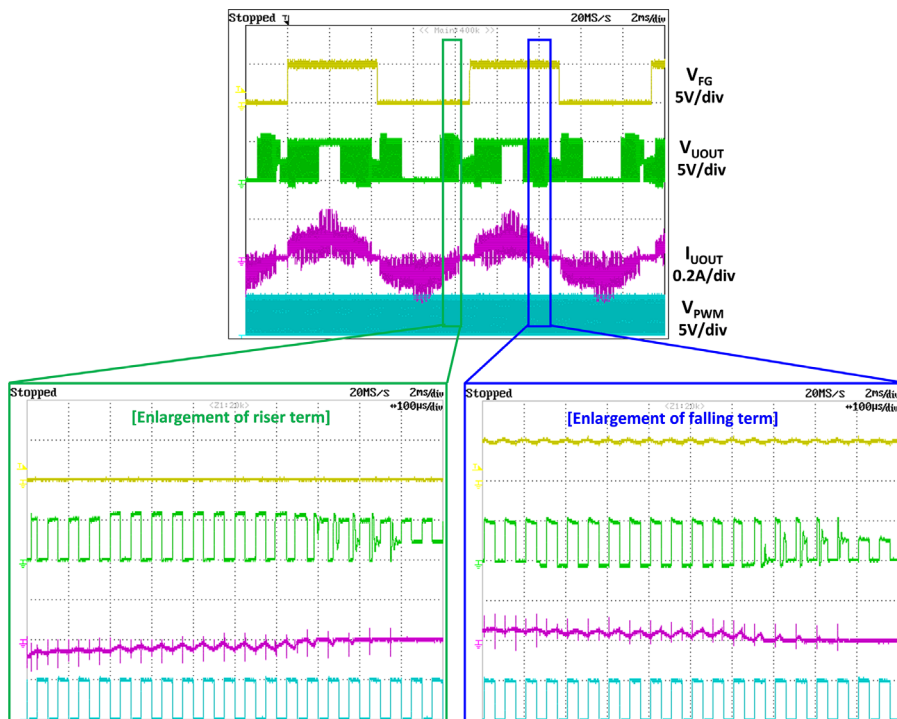

Figure 5. The Image of Waveforms of Example 2
(PWMIN Duty-cycle = 50%, VDD = 5 V)

LV8806QAGEVB

Detail Description of LV8806QA Operation

Please refer to LV8806QA Application Note:

<https://www.onsemi.jp/pub/Collateral/ANDLV8806QA-D.PDF>

Cautions

- This is intended for an initial evaluation of LV8806QA. It will not be guaranteed measurement values as full evaluation and validation must be performed on your system independently.
- Never hold the motor with the lead wire or shaft. The motor should be affixed to a stand prior to operation.
- Attach all motor leads prior to application of power.

Safety

- Do not touch the rotating part when the motor is powered. Doing so may result in injury.
- Do not touch conductive parts such as connectors when the motor is powered. Doing so may result in electric shocks.

ON Semiconductor and the ON Semiconductor logo are trademarks of Semiconductor Components Industries, LLC dba ON Semiconductor or its subsidiaries in the United States and/or other countries. ON Semiconductor owns the rights to a number of patents, trademarks, copyrights, trade secrets, and other intellectual property. A listing of ON Semiconductor's product/patent coverage may be accessed at www.onsemi.com/site/pdf/Patent-Marking.pdf. ON Semiconductor is an Equal Opportunity/Affirmative Action Employer. This literature is subject to all applicable copyright laws and is not for resale in any manner.

The evaluation board/kit (research and development board/kit) (hereinafter the "board") is not a finished product and is as such not available for sale to consumers. The board is only intended for research, development, demonstration and evaluation purposes and should as such only be used in laboratory/development areas by persons with an engineering/technical training and familiar with the risks associated with handling electrical/mechanical components, systems and subsystems. This person assumes full responsibility/liability for proper and safe handling. Any other use, resale or redistribution for any other purpose is strictly prohibited.

The board is delivered "AS IS" and without warranty of any kind including, but not limited to, that the board is production-worthy, that the functions contained in the board will meet your requirements, or that the operation of the board will be uninterrupted or error free. ON Semiconductor expressly disclaims all warranties, express, implied or otherwise, including without limitation, warranties of fitness for a particular purpose and non-infringement of intellectual property rights.

ON Semiconductor reserves the right to make changes without further notice to any board.

You are responsible for determining whether the board will be suitable for your intended use or application or will achieve your intended results. Prior to using or distributing any systems that have been evaluated, designed or tested using the board, you agree to test and validate your design to confirm the functionality for your application. Any technical, applications or design information or advice, quality characterization, reliability data or other services provided by ON Semiconductor shall not constitute any representation or warranty by ON Semiconductor, and no additional obligations or liabilities shall arise from ON Semiconductor having provided such information or services.

The boards are not designed, intended, or authorized for use in life support systems, or any FDA Class 3 medical devices or medical devices with a similar or equivalent classification in a foreign jurisdiction, or any devices intended for implantation in the human body. Should you purchase or use the board for any such unintended or unauthorized application, you shall indemnify and hold ON Semiconductor and its officers, employees, subsidiaries, affiliates, and distributors harmless against all claims, costs, damages, and expenses, and reasonable attorney fees arising out of, directly or indirectly, any claim of personal injury or death associated with such unintended or unauthorized use, even if such claim alleges that ON Semiconductor was negligent regarding the design or manufacture of the board.

This evaluation board/kit does not fall within the scope of the European Union directives regarding electromagnetic compatibility, restricted substances (RoHS), recycling (WEEE), FCC, CE or UL, and may not meet the technical requirements of these or other related directives.

FCC WARNING – This evaluation board/kit is intended for use for engineering development, demonstration, or evaluation purposes only and is not considered by ON Semiconductor to be a finished end product fit for general consumer use. It may generate, use, or radiate radio frequency energy and has not been tested for compliance with the limits of computing devices pursuant to part 15 of FCC rules, which are designed to provide reasonable protection against radio frequency interference. Operation of this equipment may cause interference with radio communications, in which case the user shall be responsible, at its expense, to take whatever measures may be required to correct this interference.

ON Semiconductor does not convey any license under its patent rights nor the rights of others.

LIMITATIONS OF LIABILITY: ON Semiconductor shall not be liable for any special, consequential, incidental, indirect or punitive damages, including, but not limited to the costs of requalification, delay, loss of profits or goodwill, arising out of or in connection with the board, even if ON Semiconductor is advised of the possibility of such damages. In no event shall ON Semiconductor's aggregate liability from any obligation arising out of or in connection with the board, under any theory of liability, exceed the purchase price paid for the board, if any.

For more information and documentation, please visit www.onsemi.com.

PUBLICATION ORDERING INFORMATION

LITERATURE FULFILLMENT:

Email Requests to: orderlit@onsemi.com

ON Semiconductor Website: www.onsemi.com

TECHNICAL SUPPORT

North American Technical Support:

Voice Mail: 1 800-282-9855 Toll Free USA/Canada

Phone: 011 421 33 790 2910

Europe, Middle East and Africa Technical Support:

Phone: 00421 33 790 2910

For additional information, please contact your local Sales Representative