

## Data sheet

Commercial Art.No.: 25.620.0353.0

PCB connector 8813 B / 3

PCB female connector with screw connection with rising cage clamp system, 3 poles, printed version, max. cross section: 1.5 mm<sup>2</sup>, pitch: 3.81 mm, type of packing: carton, color: grey

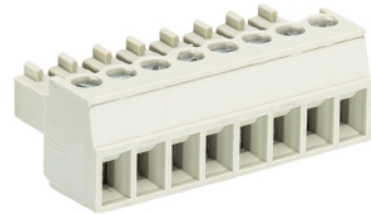

Certificates / Approvals



## Technical data

### General

Modular spacing	3.81 mm
Connection type	Screw connection
Soldering process	None
Packaging	Carton
Number of poles	3
Marking	Yes
Fastening	None
Mating direction towards connector	180°

### Technical data

Nominal cross section	1.5 mm <sup>2</sup>
Rated current	8 A
Overvoltage Category I	690 V
Overvoltage Category II	250 V
Overvoltage Category III	125
Rated impulse voltage	2.5 kV
Wire strip length	6.5 mm

### Connection Data

Minimum cross section solid	0.14 mm <sup>2</sup>
Maximum cross section solid	1.5 mm <sup>2</sup>
Minimum cross section fine stranded	0.14 mm <sup>2</sup>
Maximum cross section fine stranded	1.5 mm <sup>2</sup>
Wire strip length	6.5 mm

### Technical Data UL/CSA

Cross section UL	30-16 AWG
Voltage UL	300 V
Current field wiring	8 A
Current factory wiring	8 A
Cross section CSA	22-14 AWG
Voltage CSA	300 V

Current CSA	5 A
-------------	-----

**Other**

Type of insulation material	Thermoplastic
Color	Grey
Height	11.1 mm
Length	12.22 mm
Depth	15.5 mm
Material attachment screw	Steel
Material contact base	CuSn
Material contact surface	Sn

**Classification**

ECLASS 11	
ECLASS 8.1	27440402
ETIM 7.0	EC002637
ETIM 6.0	EC002637
ETIM 5.0	EC002637
ETIM 4.0	EC002637

**Product compliance**

ROHS conformity status	Compliant/Exempted
ROHS exceptions	III-6(c)
REACH-SVHC conformity status	Duty-To-Declare
REACH-SVHC substances	Lead
REACH-SVHC CAS numbers	7439-92-1

8-polige Ausführung gezeichnet  
 Ab 7-polige Ausführung ohne Bremsflächen  
 8 pole version drawn  
 No ribs drawn on the outer surface of the first  
 and last pole from 7 pole version

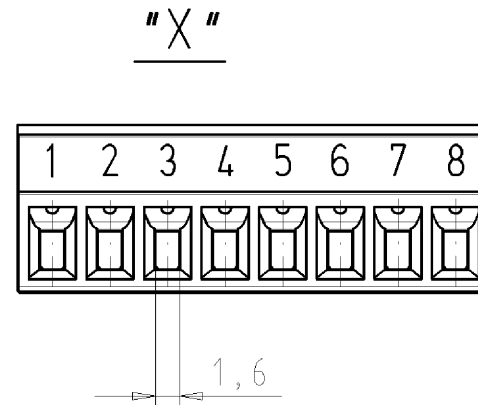
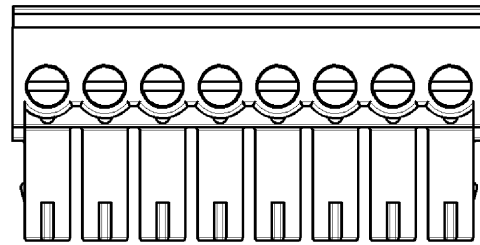
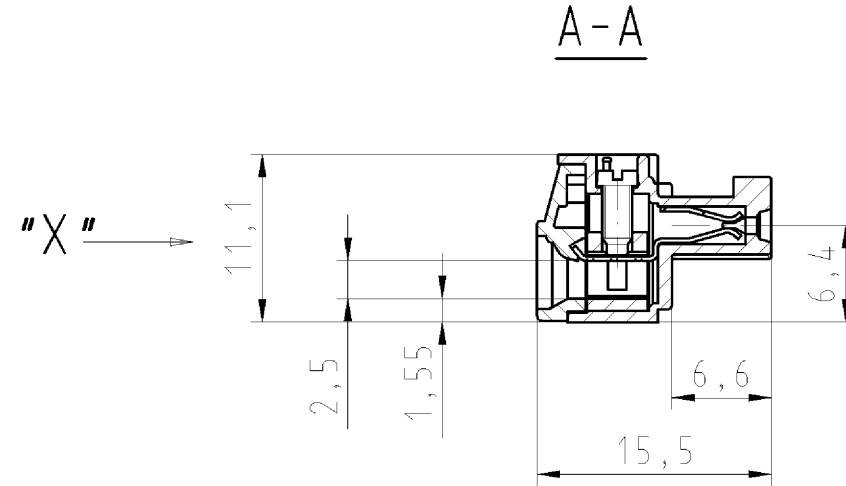
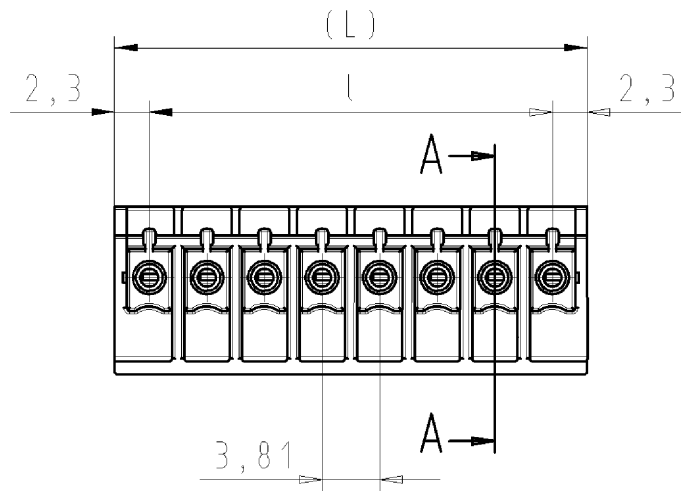

4-polige Ausführung gezeichnet  
 4 pole version drawn

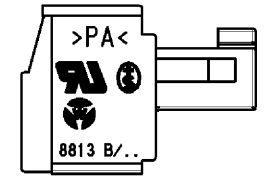
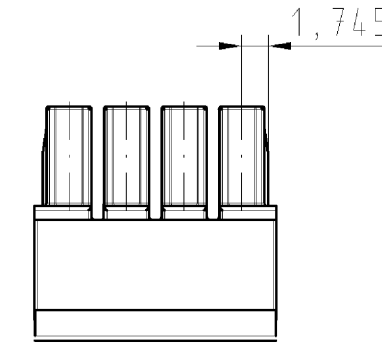

Bei 2-6polige Ausführung  
 (25.620.0253.F, 25.620.0353.F, 25.620.0453.F,  
 25.620.0553.F, 25.620.0653.F)  
 sind am Isoliergehäuse Bremsflächen an den  
 Außenflächen am ersten und letzten Pol

2-6 pole version  
 (25.620.0253.F, 25.620.0353.F, 25.620.0453.F,  
 25.620.0553.F, 25.620.0653.F)  
 with ribs on the outer surface  
 of the first and last pole

○ Diese Maße werden bei Abnahme besonders geprüft  
 ○ Ausschließlich Prüfmaße  
 ○ M11/Æ Rekanzeichene Maße sind nur für interne Zwecke gültig

Artikel-Nr. part-no.	Pol- zahl pole	L	l	Typ type
25.620.0253.F	2	8,41	3,81	8813 B/ 2
25.620.0353.F	3	12,22	7,62	8813 B/ 3
25.620.0453.F	4	16,03	11,43	8813 B/ 4
25.620.0553.F	5	19,84	15,24	8813 B/ 5
25.620.0653.F	6	23,65	19,05	8813 B/ 6
25.620.0753.F	7	27,46	22,86	8813 B/ 7
25.620.0853.F	8	31,27	26,67	8813 B/ 8
25.620.0953.F	9	35,08	30,48	8813 B/ 9
25.620.1053.F	10	38,89	34,29	8813 B/ 10
25.620.1153.F	11	42,70	38,10	8813 B/ 11
25.620.1253.F	12	46,51	41,91	8813 B/ 12
25.620.1353.F	13	50,32	45,72	8813 B/ 13
25.620.1453.F	14	54,13	49,53	8813 B/ 14
25.620.1553.F	15	57,94	53,34	8813 B/ 15
25.620.1653.F	16	61,75	57,15	8813 B/ 16
25.620.1753.F	17	65,56	60,96	8813 B/ 17
25.620.1853.F	18	69,37	64,77	8813 B/ 18
25.620.1953.F	19	73,18	68,58	8813 B/ 19
25.620.2053.F	20	76,99	72,39	8813 B/ 20

.F	Farbe/ colour	Bedruckung / Farbe printing / colour	Freitoleranz nach		CAD - Zeichnung, keine manuellen Änderungen			1.Verwendung: -		Bl.: 1 von 1	
			Maßstab	2005	Tag	Name	Zeichnung Nr.		Index		
.0	grau/grey	schwarz/black	2:1	Entworfen	12.04.	Treschan	T	25.620.0253.0 01K		a	
.1	schwarz/black	weiß/white	Vol.	Geprüft	-	-	Ersatz für:				
.7	grün/green	schwarz/black	Normgepr.	<b>wieland</b> Elektrische Verbindungen			Typ	Benennung <b>LP_STECKKLEMME</b> mit Steck- u. Schraubanschluss, Rastermaß/Pitch 3,81 Pluggable PCB terminal, rising cage clamp system			

Weitere Daten siehe Katalog  
 further data see catalog

Weitergabe sowie Vervielfältigung dieses Dokuments, Verwertung und Mitteilung  
 seines Inhalts sind verboten, soweit nicht ausdrücklich gestattet.  
 The reproduction, distribution and utilization of this document as well as the  
 communication of its contents to others without express authorization is prohibited.