



Screw Connectors for Printed Circuit Boards

TYPE 971 (-DS)

5 mm spacing - 2 to 32 poles



Distributor Stock Check



RoHS WEEE Pb free compliant

Description

- Solid version
- Wire entrance perpendicular to PC Board

Technical Data

Center to Center Spacing: 5 mm (0.197 in.)

Nominal Cross Section:

2.5 mm² (3874 mils²)

Wire Stripping Length: 5.5 mm (0.22 in.)

Recommended Hole Diameter in PC Board:

1.3 mm (0.051 in.)

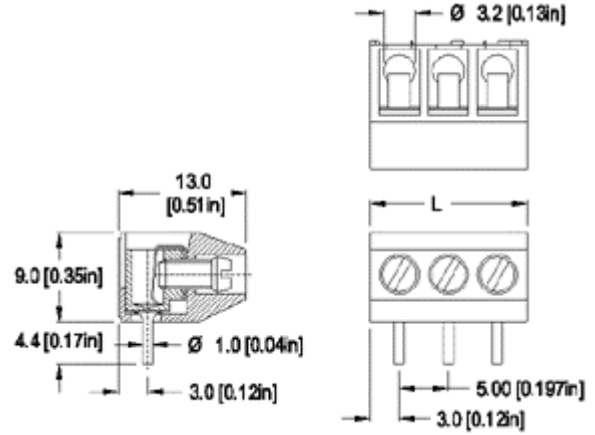

Dimensions: mm (in.)

Length of Connector (L)

L = No. of Poles x Center to Center Spacing + 1 mm

When locating connector, allow 0.5 mm clearance around it for process-induced variations.

Approval Information

UL File No.E69841

CSA File No.LR24322

Rating	Current(A)	Voltage(V)	Application group	AWG
UL	20	300	B,D	26-12
CSA	15	300	B,D,E	22-10

* Version DS is CSA certified for 26-10 AWG.
UL: 24-26 AWG range for factory wiring only.

Screw Tightening Torque:

UL: 4.5 lbf·in

CSA: 0.51 Nm

International Approvals:



Rated Impulse Withstand Voltage: 2500 V

Material

Version: 2 to 8 poles

Molding: Polyamide, self extinguishing UL 94, V-0, color grey

Temperature limits:

Short Time: 140°C (284°F)

Continuous: RTI 105°C (221°F)

Low Limit: -40°C (-40°F)

Comparative Tracking Index: CTI > 600

Oxygen Index Rating: 32%

Version: 9 to 32 poles

Molding: Polyamide (glass fiber reinforced), self extinguishing UL 94, V-0, color grey

Temperature limits:

Short Time: 200°C (392°F)

Continuous: RTI 105°C (221°F)

Low Limit: -40°C (-40°F)

Comparative Tracking Index: CTI > 175

Oxygen Index Rating: 33%

Terminal Body: Tin plated copper alloy

Wire Protector: Tin plated copper alloy

Screw: M3, Slotted head, zinc plated blue passivated, steel substrate

Solder Pin: Ø 1.0 mm (0.04 in.), Tin plated copper alloy

Item

971 (-DS)

Options

- CN: Consecutive Numbering (hot stamped numbers)
- SM: Special Marking (please provide sketch)
- PS: Clear Chromate Passivated, zinc plated, Steel Screws
- WG: Wire Guide
- G05: Gold Plating (5 micro inches)
- G30: Gold Plating (30 micro inches)
- S30: Silver Plating (30 micro inches)
- BS: Copper Alloy Screws

Note: Plated component: terminal body

Ordering Note: Version with 10 mm spacing (973 (-DS)).

Accessories

WIRE PROTECTOR:
with: - DS

971

/

POLES:
02 to 32