

Data Sheet | Item Number: 216-244

Ferrule; Sleeve for 1.5 mm² / AWG 16; insulated; electro-tin plated; electrolytic copper; gastight crimped; acc. to DIN 46228, Part 4/09.90; black

<https://www.wago.com/216-244>



Color: ■ black

Similar to illustration

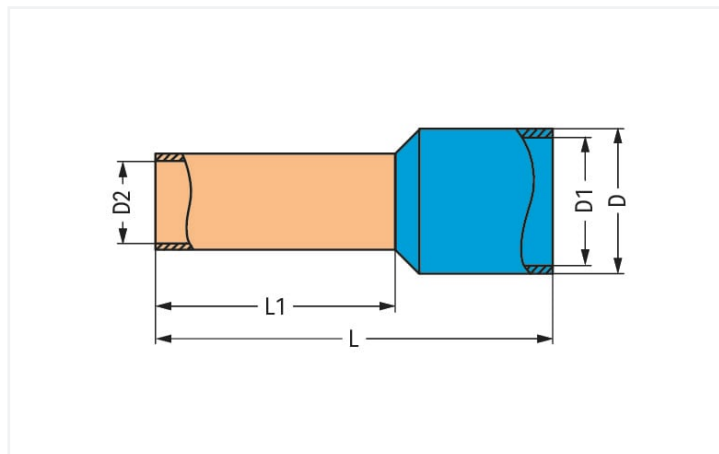

Dimensions in mm

Technical data

Sleeve cross-section (AWG)	16 AWG
Sleeve for	1.5 mm ²

Connection data

Strip length	12 mm / 0.47 inches
--------------	---------------------

Physical data

Length	16 mm
Crimp length (length of sleeve)	10 mm
Diameter	4 mm
Inner Diameter plastic collar	3.5 mm
Diameter crimp sleeve inside	1.7 mm

Mechanical data

Suitable	2001 – 2002 Series
----------	--------------------

Material data

Color	black
Fire load	0.002 MJ
Weight	0.1 g

Commercial data	
Product Group	2 (Terminal Block Accessories)
eCl@ss 10.0	27-40-02-01
eCl@ss 9.0	27-40-02-01
ETIM 9.0	EC000005
ETIM 8.0	EC000005
PU (SPU)	1000 pcs
Packaging type	Box
Country of origin	DE
GTIN	4044918016346
Customs tariff number	85369010000

Environmental Product Compliance	
RoHS Compliance Status	Compliant, No Exemption

Downloads

Environmental Product Compliance	
Compliance Search	
Environmental Product Compliance 216-244	↓

Documentation

Bid Text			
216-244	19.02.2019	xml 2.80 KB	↓
216-244	11.09.2017	doc 23.50 KB	↓

Installation Notes

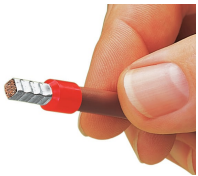

A perfect gas-tight crimp – both electrical-ly and mechanically reliable

Subject to changes. Please also observe the further product documentation!

Current addresses can be found at: www.wago.com