

Data Sheet | Item Number: 216-286

Ferrule; Sleeve for 2.5 mm² / AWG 14; insulated; electro-tin plated; electrolytic copper; gastight crimped; acc. to DIN 46228, Part 4/09.90; blue

<https://www.wago.com/216-286>



Color: ■ blue

Similar to illustration

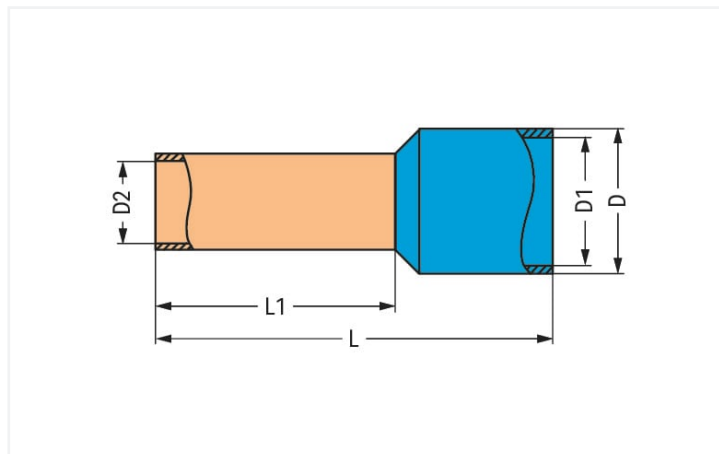

Dimensions in mm

Technical data

Sleeve cross-section (AWG)	14 AWG
Sleeve for	2.5 mm ²

Connection data

Strip length	20 mm / 0.79 inches
--------------	---------------------

Physical data

Length	25 mm
Crimp length (length of sleeve)	18 mm
Diameter	4.7 mm
Inner Diameter plastic collar	4.2 mm
Diameter crimp sleeve inside	2.2 mm

Mechanical data

Suitable	2010 to 2016 Series
----------	---------------------

Material data

Color	blue
Fire load	0 MJ
Weight	0 g

Commercial data	
Product Group	2 (Terminal Block Accessories)
eCl@ss 10.0	27-40-02-01
eCl@ss 9.0	27-40-02-01
ETIM 8.0	EC000005
ETIM 7.0	EC000005
PU (SPU)	500 pcs
Packaging type	Box
Country of origin	DE
GTIN	4055143654753
Customs tariff number	85369010000

Environmental Product Compliance	
RoHS Compliance Status	Compliant, No Exemption

Downloads

Environmental Product Compliance

Compliance Search

Environmental Product Compliance 216-286	↓
------------------------------------------	---

Documentation

Bid Text			
216-286	19.02.2019	xml 2.80 KB	↓
216-286	11.09.2017	doc 24.00 KB	↓

Installation Notes

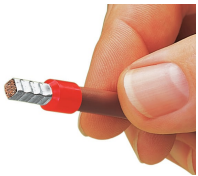

A perfect gas-tight crimp – both electrical-ly and mechanically reliable

Subject to changes. Please also observe the further product documentation!

Current addresses can be found at: www.wago.com