

## Data Sheet | Item Number: 216-110

Ferrule; Sleeve for 16 mm<sup>2</sup> / AWG 6; uninsulated; electro-tin plated; brown metallic



<https://www.wago.com/216-110>



Color:  brown metallic

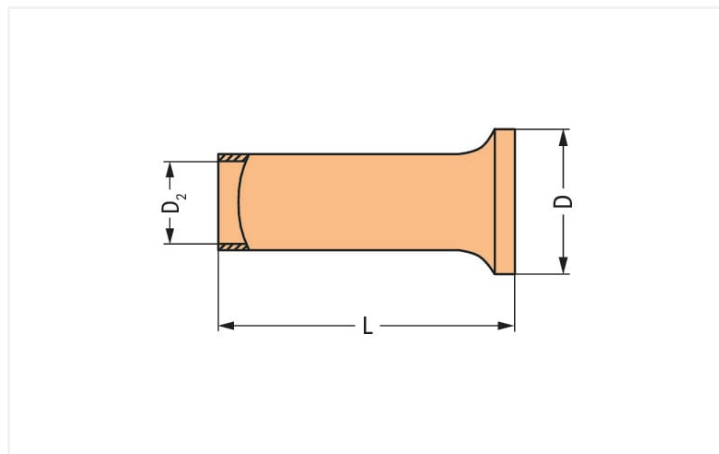

Dimensions in mm

### Technical data

|                            |                    |
|----------------------------|--------------------|
| Main product function      | Ferrule            |
| Sleeve cross-section (AWG) | 6 AWG              |
| Sleeve for                 | 16 mm <sup>2</sup> |

### Connection data

|              |                     |
|--------------|---------------------|
| Strip length | 15 mm / 0.59 inches |
|--------------|---------------------|

### Physical data

|            |        |
|------------|--------|
| Length     | 15 mm  |
| Diameter   | 7.5 mm |
| Diameter 2 | 5.8 mm |

### Material Data

|           |                |
|-----------|----------------|
| Color     | brown metallic |
| Fire load | 0 MJ           |
| Weight    | 0.5 g          |

### Commercial data

|                       |                                |
|-----------------------|--------------------------------|
| Product Group         | 2 (Terminal Block Accessories) |
| eCl@ss 10.0           | 27-40-02-01                    |
| eCl@ss 9.0            | 27-40-02-01                    |
| ETIM 8.0              | EC000005                       |
| ETIM 7.0              | EC000005                       |
| PU (SPU)              | 500 (250) pcs                  |
| Packaging type        | Box                            |
| Country of origin     | DE                             |
| GTIN                  | 4017332277723                  |
| Customs tariff number | 85369010000                    |

### Downloads

## Environmental Product Compliance

### Compliance Search

Environmental Product  
Compliance 216-110



## Documentation

### Bid Text

|         |            |                 |  |
|---------|------------|-----------------|--|
| 216-110 | 11.09.2017 | doc<br>24.50 KB |  |
| 216-110 | 19.02.2019 | xml<br>2.77 KB  |  |

## Installation Notes

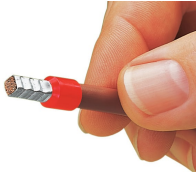

A perfect gas-tight crimp – both electrical-ly and mechanically reliable