

## Aluminum Capacitors Power Miniaturized General Purpose - Snap-In

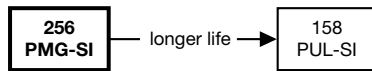

Fig. 1

### FEATURES

- Useful life: 2000 h at +105 °C, > 5000 h at +85 °C
- Voltage range from 16 V to 100 V
- Polarized aluminum electrolytic capacitors, non-solid electrolyte
- Pressure relief on the top of the aluminum case
- PET insulation sleeve
- Material categorization: For definitions of compliance please see [www.vishay.com/doc?99912](http://www.vishay.com/doc?99912)

**RoHS  
COMPLIANT**

### APPLICATIONS

- General purpose, industrial
- Standard and switched mode power supplies
- Audio systems
- DC/DC converters
- Telecom
- Smoothing and filtering

### MARKING

The capacitors are marked (where possible) with the following information:

- Rated capacitance (in  $\mu\text{F}$ )
- Tolerance on rated capacitance, code letter in accordance with IEC 60062 ( $\pm 20\%$ )
- Rated voltage (in V)
- Date code; abbreviation in 2 digits in accordance with IEC 60062
- Name of manufacturer
- Code for factory of origin (04)
- “-” sign to identify the negative terminal, visible from the top and side of the capacitor
- Relevant part of ordering code. Example MAL225638472E3, marking will show: 256 38472
- Climatic category in accordance with IEC 60068
- LL for Long Life

QUICK REFERENCE DATA	
DESCRIPTION	VALUE
Nominal case size (D x L in mm)	20 x 25 to 35 x 45
Rated capacitance range (E6 series), $C_R$	820 $\mu\text{F}$ to 47 000 $\mu\text{F}$
Tolerance on $C_R$	$\pm 20\%$
Rated voltage range, $U_R$	16 V to 100 V
Category temperature range	-40 °C to +105 °C
Endurance test at +105 °C	2000 h
Useful life at +105 °C	2000 h
Useful life at +85 °C	> 5000 h
Shelf life at 0 V, 105 °C	1000 h
Based on sectional specification	IEC 60384-4/EN130300
Climatic category IEC 60068	40/105/56

SELECTION CHART FOR $C_R$ , $U_R$ , AND RELEVANT NOMINAL CASE SIZES ( $\varnothing$ D x L in mm)							
$C_R$ ( $\mu\text{F}$ )	$U_R$ (V)						
	16	25	35	50	63	80	100
820	-	-	-	-	-	-	22 x 30
1200	-	-	-	-	22 x 25	-	25 x 30
1500	-	-	-	-	-	22 x 35	-
2200	-	-	-	22 x 25	22 x 30	25 x 30	25 x 40
2700	-	-	-	22 x 25	-	-	30 x 35
3300	-	-	22 x 25	22 x 30	25 x 35	35 x 25	30 x 40
3900	-	-	-	22 x 35	-	-	-
4700	-	-	22 x 25	25 x 30	25 x 40	35 x 30	35 x 40
5600	-	-	-	-	-	35 x 45	35 x 45
6800	-	-	25 x 30	25 x 40	35 x 30	35 x 40	-
10 000	20 x 25	-	30 x 30	30 x 40	35 x 40	-	-
15 000	22 x 30	22 x 40	-	-	-	-	-
22 000	25 x 30	25 x 40	35 x 40	-	-	-	-
47 000	35 x 35	-	-	-	-	-	-

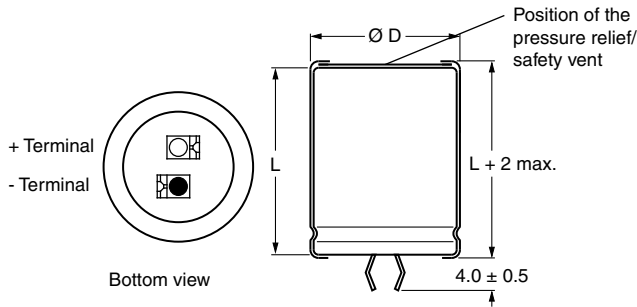
**DIMENSIONS in millimeters AND AVAILABLE FORMS**

The minus and/or plus terminal can be marked with an imprinted sign.

Fig. 2 - Two terminal snap-in

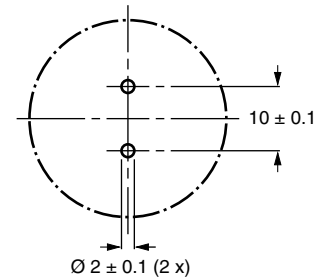

Fig. 3 - Mounting hole diagram

**Table 1**

<b>DIMENSIONS in millimeters, MASS AND PACKAGING QUANTITIES</b>					
<b>NOMINAL CASE SIZE Ø D x L</b>	<b>Ø D<sub>max.</sub></b>	<b>L<sub>max.</sub></b>	<b>MASS (g)</b>	<b>PACKAGING QUANTITIES (units per box)</b>	<b>CARDBOARD BOX DIMENSIONS L x W x H</b>
20 x 25	21	27	≈ 10	104	310 x 200 x 42
22 x 25	23	27	≈ 11	84	310 x 200 x 42
22 x 30	23	32	≈ 15	84	310 x 200 x 47
22 x 35	23	37	≈ 17	84	310 x 200 x 52
22 x 40	23	42	≈ 19	84	310 x 200 x 57
25 x 30	26	32	≈ 18	66	310 x 200 x 47
25 x 35	26	37	≈ 20	66	310 x 200 x 52
25 x 40	26	42	≈ 27	66	310 x 200 x 57
25 x 50	26	52	≈ 28	66	310 x 200 x 67
30 x 30	31	32	≈ 32	45	310 x 200 x 47
30 x 35	31	37	≈ 35	45	310 x 200 x 52
30 x 40	31	42	≈ 37	45	310 x 200 x 57
30 x 50	31	52	≈ 42	45	310 x 200 x 67
35 x 25	36	27	≈ 32	40	310 x 200 x 42
35 x 30	36	32	≈ 38	40	310 x 200 x 47
35 x 35	36	37	≈ 43	40	310 x 200 x 52
35 x 40	36	42	≈ 50	40	310 x 200 x 57
35 x 45	36	47	≈ 57	40	310 x 200 x 62

<b>ELECTRICAL DATA</b>	
<b>SYMBOL</b>	<b>DESCRIPTION</b>
C <sub>R</sub>	Rated capacitance at 120 Hz, +20 °C
I <sub>R</sub>	Rated RMS ripple current at 120 Hz, +105 °C
I <sub>L5</sub>	Max. leakage current after 5 min at U <sub>R</sub>
ESR	Max. equivalent series resistance at 120 Hz, +20 °C

**Notes**

- Unless otherwise specified, all electrical values in Table 2 apply at T<sub>amb</sub> = 20 °C, P = 86 kPa to 106 kPa, RH = 45 % to 75 %

**ORDERING EXAMPLE**

Aluminum electrolytic capacitor 256 series;  
 4700 µF/63 V;  
 2-terminal snap-in: MAL225638472E3

Table 2

ELECTRICAL DATA AND ORDERING INFORMATION								
$U_R$ (V)	$C_R$ ( $\mu$ F)	CASE SIZE $\varnothing D \times L$ (mm)	$I_R$ 120 Hz +105 °C (A)	$\tan \delta$ 120 Hz +20 °C	TYP. ESR 120 Hz +20 °C <sup>(1)</sup> ( $\Omega$ )	MAX. ESR 120 Hz +20 °C <sup>(1)</sup> ( $\Omega$ )	$I_L$ 5 min (mA)	ORDERING CODE
16	10 000	20 x 25	1.61	0.50	0.047	0.066	1.20	MAL225615103E3
	15 000	22 x 30	2.20	0.50	0.031	0.044	1.47	MAL225625153E3
	22 000	25 x 30	2.77	0.50	0.021	0.030	1.50	MAL225635223E3
	47 000	35 x 35	4.85	0.50	0.010	0.014	1.50	MAL225655473E3
25	15 000	22 x 40	2.65	0.45	0.022	0.040	1.50	MAL225626153E3
	22 000	25 x 40	3.22	0.45	0.015	0.027	1.50	MAL225636223E3
35	3300	22 x 25	1.31	0.40	0.074	0.161	1.02	MAL225620332E3
	4700	22 x 25	1.63	0.40	0.053	0.113	1.22	MAL225620472E3
	6800	25 x 30	2.04	0.40	0.037	0.078	1.46	MAL225630682E3
	10 000	30 x 30	2.75	0.40	0.027	0.053	1.50	MAL225640103E3
	22 000	35 x 40	4.69	0.40	0.013	0.024	1.50	MAL225650223E3
50	2200	22 x 25	1.48	0.35	0.088	0.211	0.99	MAL225621222E3
	2700	22 x 25	1.53	0.35	0.072	0.172	1.10	MAL225621272E3
	3300	22 x 30	1.76	0.35	0.059	0.141	1.22	MAL225621332E3
	3900	22 x 35	1.97	0.35	0.050	0.119	1.32	MAL225621392E3
	4700	25 x 30	2.18	0.35	0.042	0.099	1.45	MAL225631472E3
	6800	25 x 40	2.92	0.35	0.030	0.068	1.50	MAL225631682E3
	10 000	30 x 40	3.55	0.35	0.022	0.046	1.50	MAL225641103E3
63	1200	22 x 25	1.19	0.30	0.118	0.332	0.82	MAL225628122E3
	2200	22 x 30	1.55	0.30	0.069	0.181	1.12	MAL225628222E3
	3300	25 x 35	2.06	0.30	0.049	0.121	1.37	MAL225638332E3
	4700	25 x 40	2.51	0.30	0.038	0.085	1.50	MAL225638472E3
	6800	35 x 30	3.30	0.30	0.028	0.059	1.50	MAL225658682E3
	10 000	35 x 40	3.90	0.30	0.020	0.040	1.50	MAL225658103E3
80	1500	22 x 35	1.48	0.25	0.081	0.221	1.04	MAL225622152E3
	2200	25 x 30	1.65	0.25	0.056	0.151	1.26	MAL225632222E3
	3300	35 x 25	2.30	0.25	0.040	0.101	1.50	MAL225652332E3
	4700	35 x 30	2.64	0.25	0.030	0.071	1.50	MAL225652472E3
	5600	35 x 45	3.39	0.25	0.026	0.059	1.50	MAL225652562E3
	6800	35 x 40	3.56	0.25	0.022	0.049	1.50	MAL225652682E3
100	820	22 x 30	1.14	0.20	0.100	0.324	0.86	MAL225629821E3
	1200	25 x 30	1.56	0.20	0.072	0.221	1.04	MAL225639122E3
	2200	25 x 40	2.15	0.20	0.044	0.121	1.41	MAL225639222E3
	2700	30 x 35	2.37	0.20	0.036	0.098	1.50	MAL225649272E3
	3300	30 x 40	2.77	0.20	0.030	0.080	1.50	MAL225649332E3
	4700	35 x 40	3.30	0.20	0.023	0.056	1.50	MAL225659472E3
	5600	35 x 45	3.51	0.20	0.020	0.047	1.50	MAL225659562E3

**Note**
<sup>(1)</sup> ESR at 100 Hz is approximately 1.05 x ESR 120 Hz

ADDITIONAL ELECTRICAL DATA		
PARAMETER	CONDITIONS	VALUE
<b>Voltage</b>		
Surge voltage	at +85 °C	$U_s = 1.25 \times U_R$
Reverse voltage	at +105 °C	$U_{rev} \leq 1 V$
<b>Inductance</b>		
Equivalent series inductance (ESL)	All case sizes	Typ. 19 nH
		Max. 25 nH

**RIPPLE CURRENT AND USEFUL LIFE**

CCC208

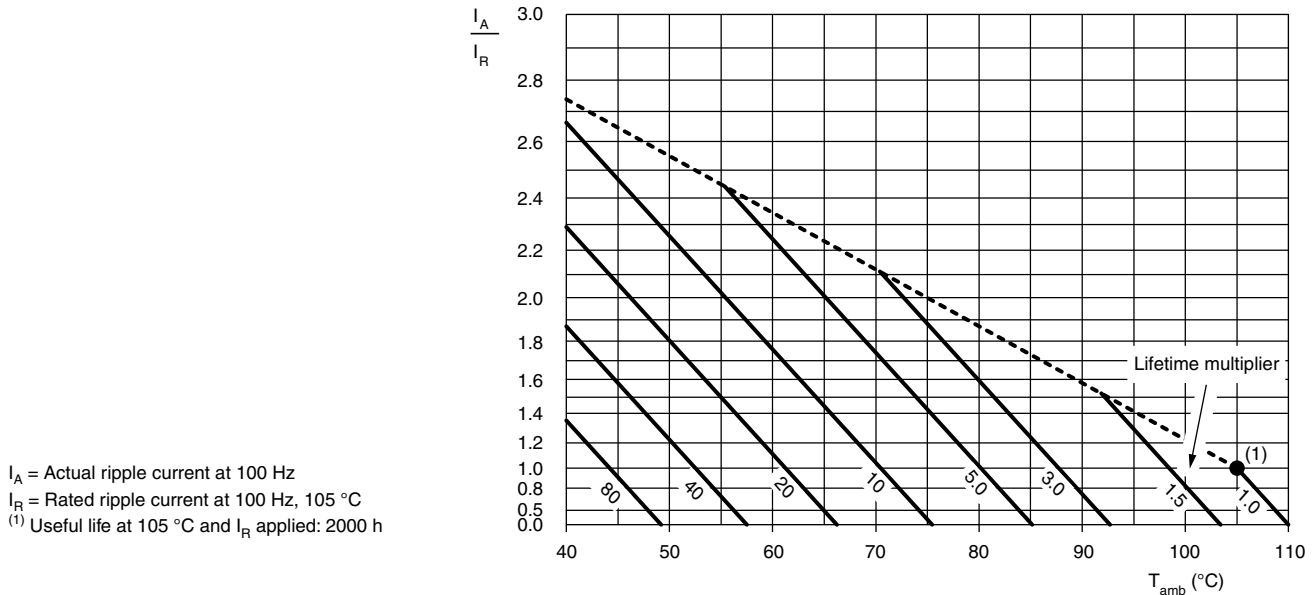

Fig. 4 - Multiplier of useful life as a function of ambient temperature and ripple current load

**Table 3**

MULTIPLIER OF RIPPLE CURRENT ( $I_R$ ) AS A FUNCTION OF FREQUENCY	
FREQUENCY (Hz)	$I_R$ MULTIPLIER
50	0.92
100	0.95
120	1.00
500	1.13
1000	1.19
≥ 10 000	1.20

**Table 4**

TEST PROCEDURES AND REQUIREMENTS			
TEST		PROCEDURE (quick reference)	REQUIREMENTS
NAME OF TEST	REFERENCE		
Endurance	IEC 60384-4/ EN130300 subclause 4.13	$T_{amb} = 105\text{ °C}$ ; $U_R$ and $I_R$ applied; 2000 h	$\Delta C/C: \pm 20\%$ $\tan \delta \leq 2 \times \text{spec. limit}$ $I_{L5} \leq \text{spec. limit}$
Useful life	CECC 30301 subclause 4.13	$T_{amb} = 105\text{ °C}$ ; $U_R$ and $I_R$ applied; 2000 h  $T_{amb} = 85\text{ °C}$ ; $U_R$ and $I_R$ applied; > 5000 h	$\Delta C/C: \pm 20\%$ $\tan \delta \leq 2 \times \text{spec. limit}$ $I_{L5} \leq \text{spec. limit}$ no short or open circuit, no visible damage total failure percentage ≤ 1 %
Shelf life (storage at high temperature)	IEC 60384-4/ EN130300 subclause 4.17	$T_{amb} = 105\text{ °C}$ ; no voltage applied; 1000 h after test: $U_R$ to be applied for 30 min, 24 h to 48 h before measurement	$\Delta C/C: \pm 20\%$ $\tan \delta \leq 1.5 \times \text{spec. limit}$ $I_{L5} \leq 2 \times \text{spec. limit}$
Vibration	IEC 60384-4/ EN130300 subclause 4.8	10 Hz to 55 Hz; 0.037 m or 5 g (whichever is less); 3 axis; 2 h per axis	$\Delta C/C: \pm 10\%$ $\tan \delta \leq \text{spec. limit}$ $I_{L5} \leq \text{spec. limit}$