

## Ceramic Disc Capacitors Class 1 and 2, 500 V (DC) General Purpose

**FEATURES**

- Low losses
- High stability
- High capacitance in small size
- Kinked (preferred) or straight leads.
- Lead (Pb)-free available.

**APPLICATIONS**

- Bypassing
- Coupling
- Resonant circuit.

**DESIGN**

The capacitors consist of a ceramic disc both sides of which are silver-plated. Connection leads are made of tinned copper having a diameter of 0.6 mm.

The capacitors have inward kinked leads with a spacing of 5 mm (0.200") or 7.5 mm (0.300") and a lead length from 4 to 30 mm. Encapsulation is made of phenolic resin.

**CAPACITANCE RANGE:**

Class 1, at 1 MHz, 1.2 V (RMS); 10 to 82 pF  
1 kHz,  $1 \pm 0.2$  V (RMS) for capacitance values higher than 1000 pF.

Class 2, at 1 kHz,  $1 \pm 0.2$  V (RMS); 100 to 22000 pF

**RATED DC VOLTAGE:**

500 V

**DIELECTRIC STRENGTH:**

250 % of rated voltage

**INSULATION RESISTANCE AT 500V (DC):**

$\geq 10000$  M $\Omega$

**TOLERANCE ON CAPACITANCE:**

$\pm 5$  %;  $\pm 10$  %;  $\pm 20$  %; + 80 /- 20 %

**DISSIPATION FACTOR:**

Class 1,  $C \leq 30$  pF;  $\leq 20 \times (10/C + 0.7) \times 10^{-4}$  maximum

Class 1,  $C > 30$  pF;  $\leq 20 \times 10^{-4}$

Class 2,  $\leq 3.0$  %

**TEMPERATURE COEFFICIENTS:**

Class 1 C0G (NP0); SL0

Class 2 Y5P; Z5U; Y5V

The capacitors meet the essential requirements of "EIA 198". Unless stated otherwise all electrical values apply at an ambient temperature of  $25 \pm 3$  °C, at normal atmospheric conditions

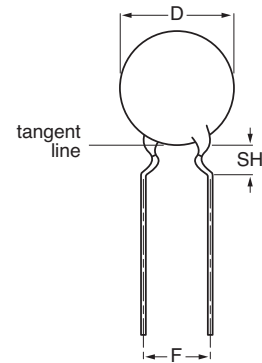

Capacitors with 5 mm (0.20") lead spacing.

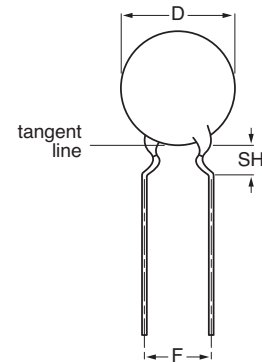

Capacitors with 7.5 mm (0.30") lead spacing.

**SECTIONAL SPECIFICATIONS:**

Class 1 IEC 60 384-8,

Class 2 IEC 60 384-9,

EIA 198

**CLIMATIC CATEGORY:**

Class 1 55/125/21

Class 2 10/85/21 and 30/85/21

**OPERATING TEMPERATURE RANGE:**

Class1 - 55 to +125 °C

Class 2 - 30 to + 85 °C

**MARKING**

Marking indicates capacitance value and tolerance in accordance with "EIA 198".



<b>ORDERING INFORMATION (PREFERRED TYPES), CLASS 1, 500 V (DC), KINKED</b>											
C (pF)	TOL. (%)	D <sub>max</sub> (mm)	LEAD SPACING F (mm)	SH <sup>(2)</sup> (mm)	CLEAR TEXT CODE			PACKAGING CODE 8 <sup>th</sup> AND 9 <sup>th</sup> DIGIT <sup>(3)</sup>			CATALOG NUMBER <sup>(4)</sup> 3 <sup>rd</sup> DIGIT: 5 = STANDARD 8 = RoHS COMPLIANT
					13 <sup>th</sup> DIGIT: T = REEL; U = AMMO; 3 = BULK 16 <sup>th</sup> DIGIT: R = RoHS COMPLIANT	REEL	AMMO	BULK			
<b>CLASS 1 NP0</b>											
10	± 5	5.0	5.0	4.0	D100J20C0GL6.J5.			06	08	10	22.2 508 ..005
12					D120J20C0GL6.J5.						22.2 508 ..055
15					D150J20C0GL6.J5.						22.2 508 ..105
18					D180J20C0GL6.J5.						22.2 508 ..155
22					D220J25C0GL6.J5.						22.2 508 ..205
27		6.5			D270J25C0GL6.J5.						22.2 508 ..255
<b>CLASS 1 SL0</b>											
33	± 5	5.0	5.0	4.0	D330J20SL0L6.J5.			06	08	10	22.2 568 ..305
39					D390J20SL0L6.J5.						22.2 568 ..355
47					D470J20SL0L6.J5.						22.2 568 ..405
56					D560J20SL0L6.J5.						22.2 568 ..505
68					D680J25SL0L6.J5.						22.2 568 ..605
82		6.5			D820J25SL0L6.J5.						22.2 568 ..805

**Notes**

1. Maximum thickness 4.0 mm.
2. SH = seated height.
3. Packaging codes refer to inward kinked leads. Other styles available on request.
4. 3<sup>rd</sup> digit to complete RoHS catalog number. 8<sup>th</sup> and 9<sup>th</sup> digit of the catalog number to be completed with the packaging code.

<b>ORDERING INFORMATION (PREFERRED TYPES), CLASS 2, 500 V (DC), KINKED</b>											
C (pF)	TOL. (%)	D <sub>max</sub> (mm)	LEAD SPACING F (mm)	SH <sup>(2)</sup> (mm)	CLEAR TEXT CODE			PACKAGING CODE 8 <sup>th</sup> AND 9 <sup>th</sup> DIGIT <sup>(3)</sup>			CATALOG NUMBER <sup>(4)</sup> 3 <sup>rd</sup> DIGIT: 5 = STANDARD 8 = RoHS COMPLIANT
					13 <sup>th</sup> DIGIT: T = REEL; U = AMMO; 3 = BULK 16 <sup>th</sup> DIGIT: R = RoHS COMPLIANT	REEL	AMMO	BULK			
<b>CLASS 2 Y5P</b>											
100	± 10	5.0	5.0	4.0	D101K20Y5PL6.J5.			06	08	10	22.2 618 ..011
150					D151K20Y5PL6.J5.						22.2 618 ..111
220					D221K20Y5PL6.J5.						22.2 618 ..211
330					D331K20Y5PL6.J5.						22.2 618 ..311
470					D471K20Y5PL6.J5.						22.2 618 ..411
680					D681K25Y5PL6.J5.						22.2 618 ..611
1000					D102K25Y5PL6.J5.						22.2 618 ..021
1500					D152K29Y5PL6.J5.						22.2 618 ..121
2200					D222K33Y5PL6.J5.						22.2 618 ..221
3300					D332K39Y5PL6.J5.						22.2 618 ..321
4700		D472K43Y5PL6.J5.			22.2 618 ..421						
6800		D682K53Y5PL6.J7.			22.2 618 ..621						
10000		D103K69Y5PL6.J7.			22.2 618 ..031						
<b>CLASS 2 Y5V</b>											
1000	+ 80/- 20	5.0	5.0	4.0	D102Z20Y5VL6.J5.			06	08	10	22.2 638 ..023
1500					D152Z20Y5VL6.J5.						22.2 638 ..123
2200					D222Z25Y5VL6.J5.						22.2 638 ..223
3300					D332Z25Y5VL6.J5.						22.2 638 ..323
4700					D472Z29Y5VL6.J5.						22.2 638 ..423
6800					D682Z33Y5VL6.J5.						22.2 638 ..623
10000					D103Z39Y5VL6.J5.						22.2 638 ..033
15000					D153Z43Y5VL6.J5.						22.2 638 ..133
22000		D223Z53Y5VL6.J7.			22.2 638 ..233						
33000		D333Z69Y5VL6.J7.			22.2 638 ..333						

<b>ORDERING INFORMATION (PREFERRED TYPES), CLASS 2, 500 V (DC), KINKED</b>											
C (pF)	TOL. (%)	D <sub>max</sub> (mm)	LEAD SPACING F (mm)	SH <sup>(2)</sup> (mm)	CLEAR TEXT CODE		PACKAGING CODE 8 <sup>th</sup> AND 9 <sup>th</sup> DIGIT <sup>(3)</sup>			CATALOG NUMBER <sup>(4)</sup> 3 <sup>rd</sup> DIGIT: 5 = STANDARD 8 = RoHS COMPLIANT	
					13 <sup>th</sup> DIGIT: T = REEL; U = AMMO; 3 = BULK 16 <sup>th</sup> DIGIT: R = RoHS COMPLIANT	REEL	AMMO	BULK			
<b>CLASS 2 Z5U</b>											
1000	± 20	5.0	5.0	4.0	D102M20Z5UL6..J5.		06	08	10	22.2 648 ..022	
1500					D152M25Z5UL6..J5.					22.2 648 ..122	
2200					D222M25Z5UL6..J5.					22.2 648 ..222	
3300					D332M29Z5UL6..J5.					22.2 648 ..322	
4700					D472M33Z5UL6..J5.					22.2 648 ..422	
6800					D682M39Z5UL6..J5.					22.2 648 ..622	
10000		7.5	11.0	7.5	4.0	D103M43Z5UL6..J5.		-	-	31	22.2 648 ..032
15000			13.5			D153M53Z5UL6..J7.					22.2 648 ..132
22000			15.0			D223M59Z5UL6..J7.					22.2 648 ..232

**Notes**

- Maximum thickness 4.0 mm.
- SH = seated height.
- Packaging codes refer to inward kinked leads. Other styles available on request.
- 3<sup>rd</sup> digit to complete RoHS catalog number. 8<sup>th</sup> and 9<sup>th</sup> digit of the catalog number to be completed with the packaging code.

<b>PACKAGING</b>				
D <sub>max</sub> mm	SIZE CODE	PACKAGING QUANTITIES		
		BULK	REEL	AMMO
5.0 (0.20")	20	1000	2000	2000
6.5 (0.25")	25			
7.5 (0.29")	29			
8.5 (0.33")	33			
10.0 (0.39")	39			
11.0 (0.43")	43			
12.0 (0.47")	47	500	-	-
13.5 (0.53")	53			
15.0 (0.59")	59			
17.5 (0.69")	69			

**Note**

- The capacitors are supplied in bulk packaging (cardboard boxes), in tape on reel or in ammopack

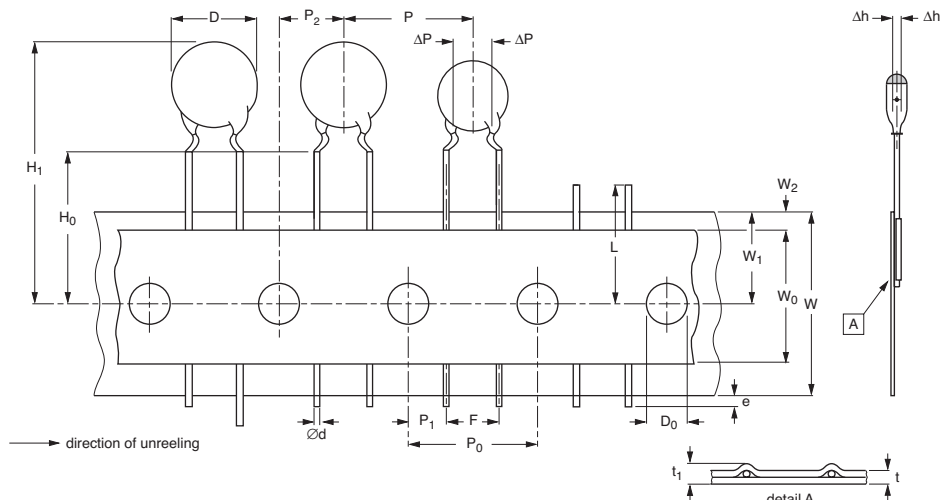

Kinked capacitors on tape, lead spacing 5.0 mm (0.2 inch).

DIMENSIONS OF TAPE			
SYMBOL	PARAMETER	DIMENSIONS (mm)	
		NOMINAL	TOLERANCE
D	body diameter	11.0 maximum	-
d	lead diameter	0.6	± 0.05
P	pitch between capacitors	12.7	± 1.0
P <sub>0</sub>	feed-hole pitch	12.7	± 0.3; note 1
ΔP	plane deviation	1.0 maximum	-
P <sub>1</sub>	feed-hole centre to lead centre	3.85	± 0.7; note 2
P <sub>2</sub>	feed-hole centre to component centre	6.35	± 1.3; note 2
F	lead spacing	5.0	+ 0.6 - 0.4
Δh	component alignment	0	± 1.0
Δs	deviation along tape, left or right	0	± 1.0
W	tape width	18.0	+ 1.0 - 0.5
W <sub>0</sub>	hold-down tape width	5.0 minimum	-
W <sub>1</sub>	hole position	9.0	+ 0.75 - 0.5
W <sub>2</sub>	hold-down tape margin	3.0 maximum	-
H <sub>0</sub>	height to seating plane	16.0	± 0.5
H <sub>1</sub>	maximum component height	32.0	-
e	lead end protrusion	1.0 maximum	-
L	maximum length of snipped lead	11.0	-
D <sub>0</sub>	feed-hole diameter	4.0	± 0.2
t	total tape thickness	0.9 maximum	-
t <sub>1</sub>	maximum thickness of tape and wires	1.5 maximum	-

**Notes**

1. Cumulative pitch error:  $\pm \leq 1$  mm /20 pitches.
2. Obliquity maximum 3°.

**REEL AND TAPE DATA** in millimeters

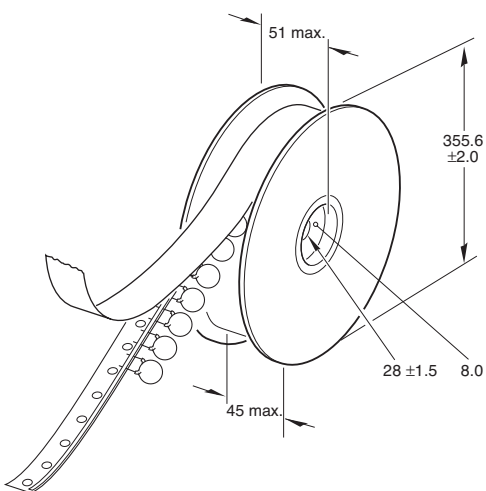

Reel with capacitors on tape.

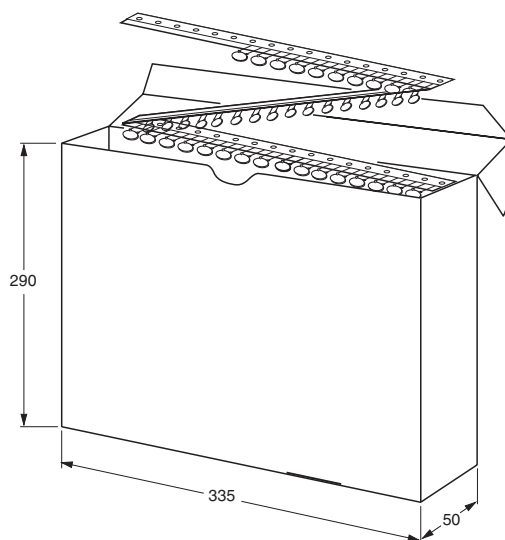

Ampopack with capacitors on tape.