



N-Channel JFETs

2N4856JAN	2N4856JANTX	2N4856JANTXV
2N4857JAN	2N4857JANTX	2N4857JANTXV
2N4858JAN	2N4858JANTX	2N4858JANTXV
2N4859JAN	2N4859JANTX	2N4859JANTXV
2N4860JAN	2N4860JANTX	2N4860JANTXV
2N4861JAN	2N4861JANTX	2N4861JANTXV

PRODUCT SUMMARY					
Part Number	V _{GS(off)} (V)	V _{(BR)GSS} Min (V)	r _{DS(on)} Max (Ω)	I _{D(off)} Max (pA)	t _{ON} Typ (ns)
2N4856	-4 to -10	-40	25	250	9
2N4857	-2 to -6	-40	40	250	10
2N4858	-0.8 to -4	-40	60	250	20
2N4859	-4 to -10	-30	25	250	9
2N4860	-2 to -6	-30	40	250	10
2N4861	-0.8 to -4	-30	60	250	20

FEATURES

- Low On-Resistance: 2N4856 <25 Ω
- Fast Switching—t_{ON}: 4 ns
- High Off-Isolation—I_{D(off)}: 5 pA
- Low Capacitance: 3 pF
- Low Insertion Loss
- N-Channel Majority Carrier FET

BENEFITS

- Low Error Voltage
- High-Speed Analog Circuit Performance
- Negligible “Off-Error,” Excellent Accuracy
- Good Frequency Response, Low Glitches
- Eliminates Additional Buffering
- High Radiation Tolerance

APPLICATIONS

- Analog Switches
- Choppers
- Sample-and-Hold
- Normally “On” Switches
- Current Limiters

DESCRIPTION

The 2N4856JAN/JANTX/JANTXV all-purpose JFET analog switches offer low on-resistance, low capacitance, good isolation, and fast switching.

Hermetically-sealed TO-206AA (TO-18) packaging allows full military processing (see Military Information). For similar products in TO-226AA (TO-92) and TO-236 (SOT-23) packages, see the J/SST111 series data sheet. For similar duals, see the 2N5564/5565/5566 data sheet.

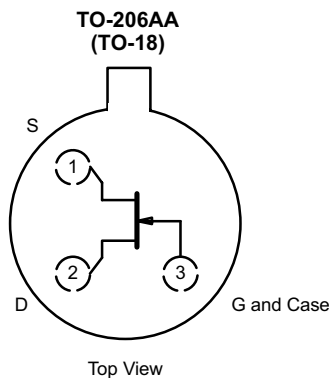



Vishay Siliconix

ABSOLUTE MAXIMUM RATINGS

Gate-Drain, Gate-Source Voltage :	
(2N4856-58)	-40 V
(2N4859-61)	-30 V
Gate Current	50 mA
Lead Temperature (¹ / ₁₆ " from case for 10 seconds)	300 °C
Storage Temperature	-65 to 200°C

Operating Junction Temperature	-65 to 200°C
Power Dissipation ^a	1800 mW

Notes

a. Derate 10.3 mW/°C to T_C > 25°C

SPECIFICATIONS FOR 2N4856, 2N4857 AND 2N4858 (T_A = 25 °C UNLESS NOTED)

Parameter	Symbol	Test Conditions	Typ ^a	Limits						Unit	
				2N4856		2N4857		2N4858			
				Min	Max	Min	Max	Min	Max		
Static											
Gate-Source Breakdown Voltage	V _{(BR)GSS}	I _G = -1 μA, V _{DS} = 0 V	-55	-40		-40		-40		V	
Gate-Source Cutoff Voltage	V _{GS(off)}	V _{DS} = 15 V, I _D = 0.5 nA		-4	-10	-2	-6	-0.8	-4		
Saturation Drain Current ^b	I _{DSS}	V _{DS} = 15 V, V _{GS} = 0 V		50	175	20	100	8	80	mA	
Gate Reverse Current	I _{GSS}	V _{GS} = -20 V, V _{DS} = 0 V		-5		-250		-250		-250	pA
			T _A = 150°C	-13		-500		-500		-500	nA
Gate Operating Current ^c	I _G	V _{DG} = 15 V, I _D = 10 mA	-5							pA	
Drain Cutoff Current	I _{D(off)}	V _{DS} = 15 V, V _{GS} = -10 V		5		250		250		250	nA
			T _A = 150°C	13		500		500		500	nA
Drain-Source On-Voltage	V _{DS(on)}	V _{GS} = 0 V	I _D = 5 mA	0.25					0.5		V
			I _D = 10 mA	0.35			0.5				
			I _D = 20 mA	0.5		0.75					
Drain-Source On-Resistance ^c	r _{DS(on)}	V _{GS} = 0 V, I _D = 1 mA			25		40		60	Ω	
Gate-Source Forward Voltage ^c	V _{GS(F)}	I _G = 1 mA, V _{DS} = 0 V	0.7							V	
Dynamic											
Common-Source Forward Transconductance ^c	g _{fs}	V _{DG} = 20 V, I _D = 1 mA f = 1 kHz	6							mS	
Common-Source Output Conductance ^c	g _{os}		25							μS	
Common-Source Input Capacitance	C _{iss}	V _{DS} = 0 V, V _{GS} = -10 V f = 1 MHz	7		18		18		18	pF	
Common-Source Reverse Transfer Capacitance	C _{rss}		3		8		8		8		
Equivalent Input Noise Voltage ^c	\bar{e}_n	V _{DG} = 10 V, I _D = 10 mA f = 1 kHz	3							nV/ √Hz	
Switching											
Turn-On Time	t _{d(on)}	V _{DD} = 10 V, V _{GS(H)} = 0 V See Switching Circuit	2		6		6		10	ns	
	t _r		2		3		4		10		
Turn-Off Time	t _{OFF}		13		25		50		100		



SPECIFICATIONS FOR 2N4859, 2N4860 AND 2N4861 (T _A = 25 °C UNLESS NOTED)											
Parameter	Symbol	Test Conditions	Typ ^a	Limits						Unit	
				2N4859		2N4860		2N4861			
				Min	Max	Min	Max	Min	Max		
Static											
Gate-Source Breakdown Voltage	V _{(BR)GSS}	I _G = -1 μA, V _{DS} = 0 V	-55	-30		-30		-30		V	
Gate-Source Cutoff Voltage	V _{GS(off)}	V _{DS} = 15 V, I _D = 0.5 nA		-4	-10	-2	-6	-0.8	-4		
Saturation Drain Current ^b	I _{DSS}	V _{DS} = 15 V, V _{GS} = 0 V		50	175	20	100	8	80	mA	
Gate Reverse Current	I _{GSS}	V _{GS} = -15 V, V _{DS} = 0 V		-5		-250		-250		-250	pA
			T _A = 150 °C	-13		-500		-500		-500	nA
Gate Operating Current ^c	I _G	V _{DG} = 15 V, I _D = 10 mA	-5							pA	
Drain Cutoff Current	I _{D(off)}	V _{DS} = 15 V, V _{GS} = -10 V		5	250		250		250		
			T _A = 150 °C	13	500		500		500		
Drain-Source On-Voltage	V _{DS(on)}	V _{GS} = 0 V	I _D = 5 mA	0.25					0.5	V	
			I _D = 10 mA	0.35			0.5				
			I _D = 20 mA	0.5	0.75						
Drain-Source On-Resistance	r _{DS(on)}	V _{GS} = 0 V, I _D = 1 mA			25		40		60	Ω	
Gate-Source Forward Voltage	V _{GS(F)}	I _G = 1 mA, V _{DS} = 0 V	0.7							V	
Dynamic											
Common-Source Forward Transconductance ^c	g _{fs}	V _{DG} = 20 V, I _D = 1 mA f = 1 kHz	6							mS	
Common-Source Output Conductance ^c	g _{os}		25							μS	
Common-Source Input Capacitance	C _{iss}	V _{DS} = 0 V, V _{GS} = -10 V f = 1 MHz	7	18		18			18	pF	
Common-Source Reverse Transfer Capacitance	C _{rss}		3	8		8		8			
Equivalent Input Noise Voltage ^c	e _n	V _{DG} = 10 V, I _D = 10 mA f = 1 kHz	3							nV/ √Hz	
Switching											
Turn-On Time	t _{d(on)}	V _{DD} = 10 V, V _{GS(H)} = 0 V See Switching Circuit	2	6		6		10		ns	
	t _r		2	3		4		10			
Turn-Off Time	t _{OFF}		19	25		50		100			

Notes

- a. Typical values are for DESIGN AID ONLY, not guaranteed nor subject to production testing.
- b. Pulse test: PW ≤ 100 μs duty cycle ≤ 10%.
- c. This parameter not registered with JEDEC.

NCB

SWITCHING TIME TEST CIRCUIT			
	4856/4859	4857/4860	4858/4861
$V_{GS(L)}$	-10 V	-6 V	-4 V
R_L^*	464 Ω	953 Ω	1910 Ω
$I_{D(on)}$	20 mA	10 mA	5 mA

*Non-inductive

INPUT PULSE

Rise Time < 1 ns
 Fall Time < 1 ns
 Pulse Width 100 ns
 PRF 1 MHz

SAMPLING SCOPE

Rise Time 0.4 ns
 Input Resistance 10 M Ω
 Input Capacitance 1.5 pF

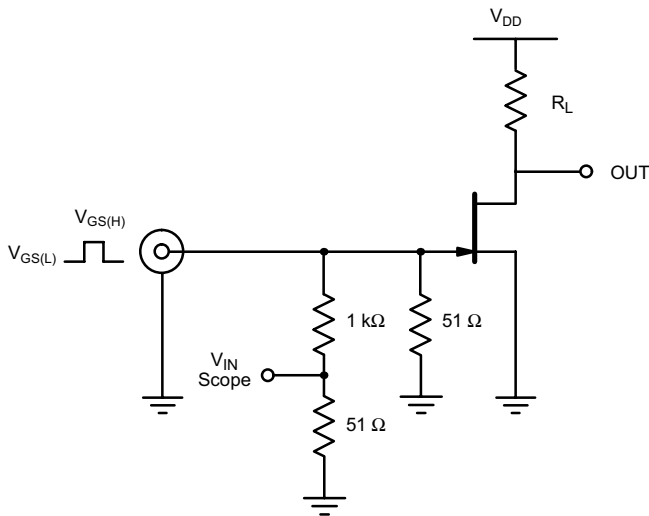
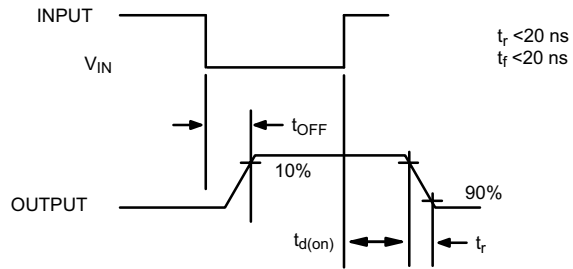



Disclaimer

All product specifications and data are subject to change without notice.

Vishay Intertechnology, Inc., its affiliates, agents, and employees, and all persons acting on its or their behalf (collectively, "Vishay"), disclaim any and all liability for any errors, inaccuracies or incompleteness contained herein or in any other disclosure relating to any product.

Vishay disclaims any and all liability arising out of the use or application of any product described herein or of any information provided herein to the maximum extent permitted by law. The product specifications do not expand or otherwise modify Vishay's terms and conditions of purchase, including but not limited to the warranty expressed therein, which apply to these products.

No license, express or implied, by estoppel or otherwise, to any intellectual property rights is granted by this document or by any conduct of Vishay.

The products shown herein are not designed for use in medical, life-saving, or life-sustaining applications unless otherwise expressly indicated. Customers using or selling Vishay products not expressly indicated for use in such applications do so entirely at their own risk and agree to fully indemnify Vishay for any damages arising or resulting from such use or sale. Please contact authorized Vishay personnel to obtain written terms and conditions regarding products designed for such applications.

Product names and markings noted herein may be trademarks of their respective owners.