

## Surface Mount, Molded, Shielded Inductors

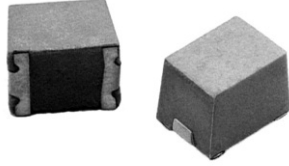

### STANDARD ELECTRICAL SPECIFICATIONS

IND. (μH)	TOL.	Q MIN.	TEST FREQ. L & Q (MHz)	SELF-RESONANT FREQ. MIN. (MHz)	DCR MAX. (Ohms)	RATED* DC CURRENT (mA)
0.10	±20%	30	25.2	460	0.23	552
0.12	±20%	30	25.2	400	0.26	519
0.15	±20%	30	25.2	390	0.29	491
0.18	±20%	30	25.2	350	0.32	468
0.22	±20%	30	25.2	310	0.36	441
0.27	±20%	30	25.2	280	0.40	418
0.33	±20%	30	25.2	240	0.45	394
0.39	±20%	30	25.2	215	0.60	342
0.47	±20%	30	25.2	205	0.75	306
0.56	±20%	30	25.2	195	0.80	296
0.68	±20%	30	25.2	165	0.95	271
0.82	±20%	30	25.2	155	1.20	242
1.0	±10%	30	7.96	140	0.35	447
1.2	±10%	30	7.96	120	0.38	429
1.5	±10%	30	7.96	100	0.40	418
1.8	±10%	30	7.96	90.0	0.43	403
2.2	±10%	30	7.96	80.0	0.46	390
2.7	±10%	30	7.96	67.0	0.49	378
3.3	±10%	30	7.96	61.0	0.55	357
3.9	±10%	30	7.96	56.0	0.59	344
4.7	±10%	30	7.96	50.0	0.62	336
5.6	±10%	30	7.96	40.0	0.69	333
6.8	±10%	30	7.96	32.0	0.75	306
8.2	±10%	30	7.96	30.0	0.82	292
10.0	±10%	50	2.52	25.0	0.90	279
12.0	±10%	50	2.52	22.0	1.0	265
15.0	±10%	50	2.52	18.0	1.10	252
18.0	±10%	50	2.52	15.0	1.24	238
22.0	±10%	50	2.52	14.0	1.36	227
27.0	±10%	50	2.52	13.0	1.56	212
33.0	±10%	50	2.52	12.0	1.72	202
39.0	±10%	50	2.52	11.0	1.89	192
47.0	±10%	50	2.52	9.0	2.10	183
56.0	±10%	50	2.52	8.0	2.34	173
68.0	±10%	50	2.52	7.6	2.60	164
82.0	±10%	50	2.52	7.2	2.86	156
100.0	±10%	50	0.796	7.0	3.25	147
120.0	±10%	50	0.796	6.0	3.64	139
150.0	±10%	50	0.796	5.0	4.16	130
180.0	±10%	40	0.796	4.5	5.72	111
220.0	±10%	40	0.796	4.2	6.30	105
270.0	±10%	40	0.796	4.0	6.90	101
330.0	±10%	40	0.796	3.7	7.54	96
390.0	±10%	40	0.796	3.5	8.20	92
470.0	±10%	40	0.796	3.3	9.20	87
560.0	±10%	40	0.796	2.8	10.50	82
680.0	±10%	40	0.796	2.6	12.0	76
820.0	±10%	40	0.796	2.2	13.50	72
1000.0	±10%	40	0.252	2.0	16.0	66

\*Rated DC Current based on the maximum temperature rise, not to exceed 40 °C at + 85 °C ambient.

### FEATURES

- Molded construction provides superior strength and moisture resistance
- Tape and reel packaging for automatic handling, 2000/reel, EIA 481
- Compatible with vapor phase and infrared reflow soldering
- Shielded construction minimizes coupling to other components
- 100 % lead (Pb)-free and RoHS compliant



**RoHS**  
COMPLIANT

### ELECTRICAL SPECIFICATIONS

**Inductance Range:** 0.10 μH to 1000 μH

**Inductance Tolerance:** ± 20 % for 0.10 μH to 0.82 μH

± 10 % for 1.0 μH to 1000 μH standard

± 10 %, ± 5 % and ± 3 % available

**Temperature Range:** - 55 °C to + 125 °C

**Coilform Material:** Non-Magnetic for 0.10 μH to 0.82 μH

Powdered iron for 1.0 μH to 22 μH. Ferrite for 27 μH to 1000 μH

### TEST EQUIPMENT

- H/P 4342A Q-meter with Vishay Dale test fixture or equivalent
- H/P 4191A RF Impedance Analyzer (for SRF measurements)
- Wheatstone bridge

### DIMENSIONS in inches [millimeters]

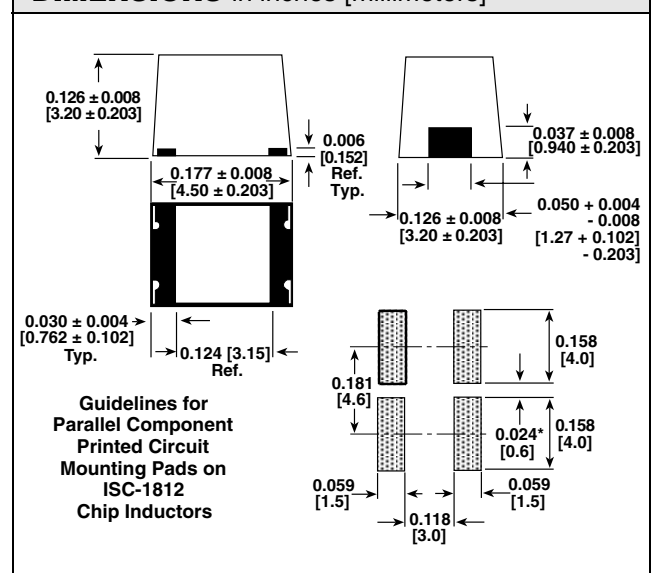

\*Recommended minimum spacing between components

# ISC-1812

Vishay Dale

Shielded Mount, Molded, Shielded Inductors



## COUPLING SPECIFICATIONS [maximum]

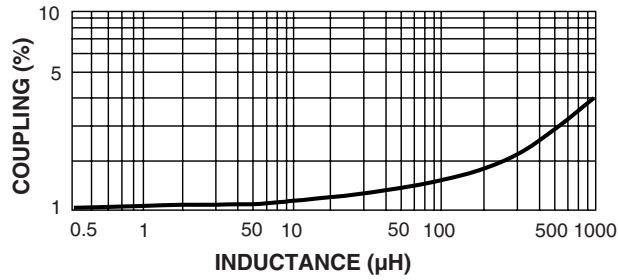

## PART MARKING

- Vishay Dale
- Inductance value
- Date code

## DESCRIPTION

ISC-1812  
MODEL

10 µH  
INDUCTANCE  
VALUE

± 10 %  
INDUCTANCE  
TOLERANCE

ER  
PACKAGE  
CODE

e3  
JEDEC LEAD (Pb)-FREE  
STANDARD

## GLOBAL PART NUMBER

I S C  
PRODUCT FAMILY

1 8 1 2  
SIZE

E R  
PACKAGE CODE

1 0 0  
INDUCTANCE VALUE

K  
TOL.



## Notice

Specifications of the products displayed herein are subject to change without notice. Vishay Intertechnology, Inc., or anyone on its behalf, assumes no responsibility or liability for any errors or inaccuracies.

Information contained herein is intended to provide a product description only. No license, express or implied, by estoppel or otherwise, to any intellectual property rights is granted by this document. Except as provided in Vishay's terms and conditions of sale for such products, Vishay assumes no liability whatsoever, and disclaims any express or implied warranty, relating to sale and/or use of Vishay products including liability or warranties relating to fitness for a particular purpose, merchantability, or infringement of any patent, copyright, or other intellectual property right.

The products shown herein are not designed for use in medical, life-saving, or life-sustaining applications. Customers using or selling these products for use in such applications do so at their own risk and agree to fully indemnify Vishay for any damages resulting from such improper use or sale.