

Unigen Corp. Wireless Module Products

Part Number Family:
Wideband UHF Radio Modules
UGW3S4XESM33 (PAN-SMT-400)
UGW3S8XESM33 (PAN-SMT-800)
UGW3S9XESM33 (PAN-SMT-900)

Issue Date: 10-Dec-08

Revision: 0.9

Revision History

Rev. No.	History	Issue Date	Remarks
0.7	Draft	2-Jul-08	Initial draft entire document
0.8	Draft	29-Jul-08	Made changes including pin locations.
0.9	Draft	10-Dec-08	Add FCC Cert info when available and roll to Rev 1.0

THIS DOCUMENT IS PROVIDED "AS IS" WITH NO WARRANTIES WHATSOEVER, INCLUDING ANY WARRANTY OF MERCHANTABILITY, NON-INFRINGEMENT, FITNESS FOR ANY PARTICULAR PURPOSE, OR ANY WARRANTY OTHERWISE ARISING OUT OF ANY PROPOSAL, SPECIFICATION OR SAMPLE.

Unigen Corporation disclaims all liability, including liability for infringement of any proprietary rights, relating to use of information in this document. No license, expressed or implied, by estoppel or otherwise, to any intellectual property rights is granted herein.

*Third-party brands, names, and trademarks are the property of their respective owners.

TABLE OF CONTENTS

LIST OF FIGURES	3
PRODUCT INTRODUCTION	4
FEATURES AND BENEFITS	4
PRODUCT DESCRIPTION	6
PAN Module	6
XE1203 Transceiver IC	6
Functional Block Diagrams	7
PIN ASSIGNMENT	9
PIN FUNCTIONS	10
ABSOLUTE MAXIMUM RATINGS	11
RECOMMENDED OPERATING CONDITIONS	11
RF AND ELECTRICAL CHARACTERISTICS	12
AGENCY CERTIFICATIONS (PRE-SCAN)	13
REGULATORY COMPLIANCE STATEMENT	13
FUNCTIONAL OVERVIEW	14
PAN Module Functional Description	14
XE1203 Functional Description	14
DIGITAL INTERFACE	16
Serial Control Interface	16
Control Registers	17
ConfigSwitch	17
RTPParam	19
FSPParam	20
SWParam	21
DataOut	23
ADParam	24
PATParam	25
TParam	26
OPERATING MODES	27
TYPICAL APPLICATION CIRCUIT	29
MECHANICAL DRAWINGS	30
PRODUCTION GUIDELINES	33
Manual Assembly	33
Automated Assembly	33
Washing	34
Solder Profiles	35
REFERENCE DOCUMENTATION	36
CONTACT INFORMATION	36

LIST OF FIGURES

Module Block Diagram	7
XE1203 Block Diagram	8
PAN Module Pin Locations	9
Pin Assignment	10
RF Characteristics	12
Clock Specifications	13
Control Registers	15
SPI Read and Write Sequences	16
Configuration and Status Registers	17
ConfigSwitch	18
RTPParam	19
FSPParam	20
SWParam	21
Examples of LO frequency settings	22
DataOut	23
ADParam	24
PATParam	25
Pattern recognition with a 32-bit pattern	25
Pattern recognition with an 8-bit pattern	25
Operating Modes	27
Tx RX Switching	28
Standard Tx/Rx Switching Sequence	28
Typical microcontroller interface	29
Module Dimensions and Pin Location	30
Recommended PCB Layout	31
Tape and Reel Dimensions	32

PRODUCT INTRODUCTION

The Unigen PAN products are drop-in replacements for Semtech DP1203 modules. This product is based on the Semtech XE1203 UHF transceiver. Three versions are available; 902, 868 and 433 MHz. The PAN transceiver module is an SPI peripheral used with an external microcontroller. A 50 Ohm single-ended RF interface is provided for user defined antenna or transmission line on the mother board. Pan offers excellent receiver sensitivity and generous link budget for wideband systems. UHF bands offer superior range and Non-Line-of-Sight performance compared to 2.4 GHz systems.

FEATURES AND BENEFITS

- Drop-in Replacement for Semtech DP1203 Modules
- Wideband UHF Transceiver Module
- UHF ISM BANDS: 433, 868 or 915 MHz
- Max Data Rate 152.3 kbit/s
- Best Sensitivity -111 dBm @ 4.8 kbps
- Programmable RF Power Output up to +15 dBm
- Programmable Frequency Synthesizer
- Programmable Base-band Filter 600 kHz/CH max
- 915, 868 or 433 MHz ISM Band-pass SAW filters included
- Supports Direct Sequence Spread Spectrum DSSS
- 11-Chip Barker encoder/decoder
- Pattern Recognition (IRQ on match)
- RSSI Window Comparator with IRQ
- Rx Bit-Synchronizer for stable Data and glitch-free clock recovery
- De-Multiplexed Data and Control Busses
- Digital Direct Interface for Data and Bit Clock
- Independent SPI Interface for control
- User Defined 50 Ohm Antenna
- Surface Mount with tape and reel packaging
- 30.5 mm x 18.5 mm
- Supply Voltage 2.4 V – 3.6 V
- Rx Line Power 14 mA typ
- Tx Line Power 62 mA @ +11 dBm typ
- Line Power Sleep Mode 200 nA typ
- Industrial Temperature Rating -40 to +85 °C
- RoHS 6 Compliant

Applications

- long-range low-power systems
- Point-to-Point Systems
- Point-to-Multi-Point Systems
- Non-Line-of-Sight radio links
- Wide-band Security Systems
- Process Controls
- Building Controls
- Access Controls
- Factory Automation
- Home Automation
- Home Appliance Interconnections
- Industrial Equipment Controls
- Remote sensor status and control
- Telemetry
- Cable Replacement
- Phone quality audio Wireless Local Loops
- Streaming Synchronous Data with Recovered Clock
- Konnex and KNX compatible systems
- Out-of-band control channel for 2.4 and 5 GHz systems.
- Automatic Meter Reading
- Alarms
- Baby monitors
- Irrigation controls

PRODUCT DESCRIPTION

PAN Module

The PAN is a complete UHF Radio Transceiver Module operating in the license-free ISM (Industrial Scientific and Medical) bands. The PAN modules come pre-tuned for 433, 868, or 915 MHz. Based on the Semtech XE1203 transceiver. The PAN module offers high power, excellent sensitivity, wide-band FSK and DSSS encoding/decoding for robust long-range communication. The device is suitable for applications which have to satisfy either the European (ETSI-300-220) or North American (FCC part 15) regulatory standards.

XE1203 Transceiver IC

The XE1203 single-chip solution is an integrated circuit intended for use as a low cost FSK transceiver to establish a frequency-agile, half-duplex, bi-directional RF link, with non-return to zero data coding. The device is available in a VQFN 48 package and is designed to provide a fully functional multi-channel FSK transceiver. It is intended for applications in the 433 MHz and 868 MHz European bands and the North American 915 MHz ISM band. The single chip transceiver operates down to 2.4V. Its ability to operate with 25 kHz channel spacing makes it compliant with requirements of ETSI EN300 220-1.

Functional Block Diagrams

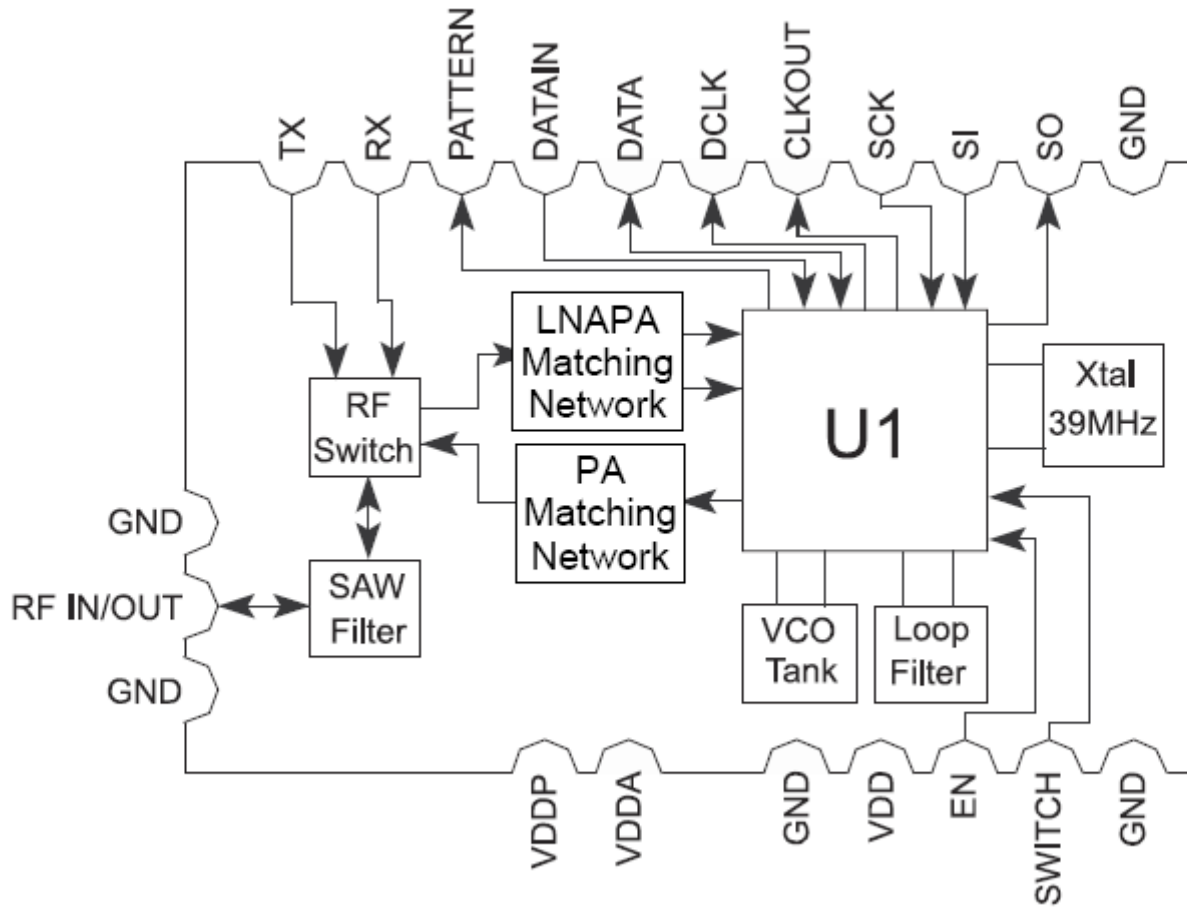

Module Block Diagram

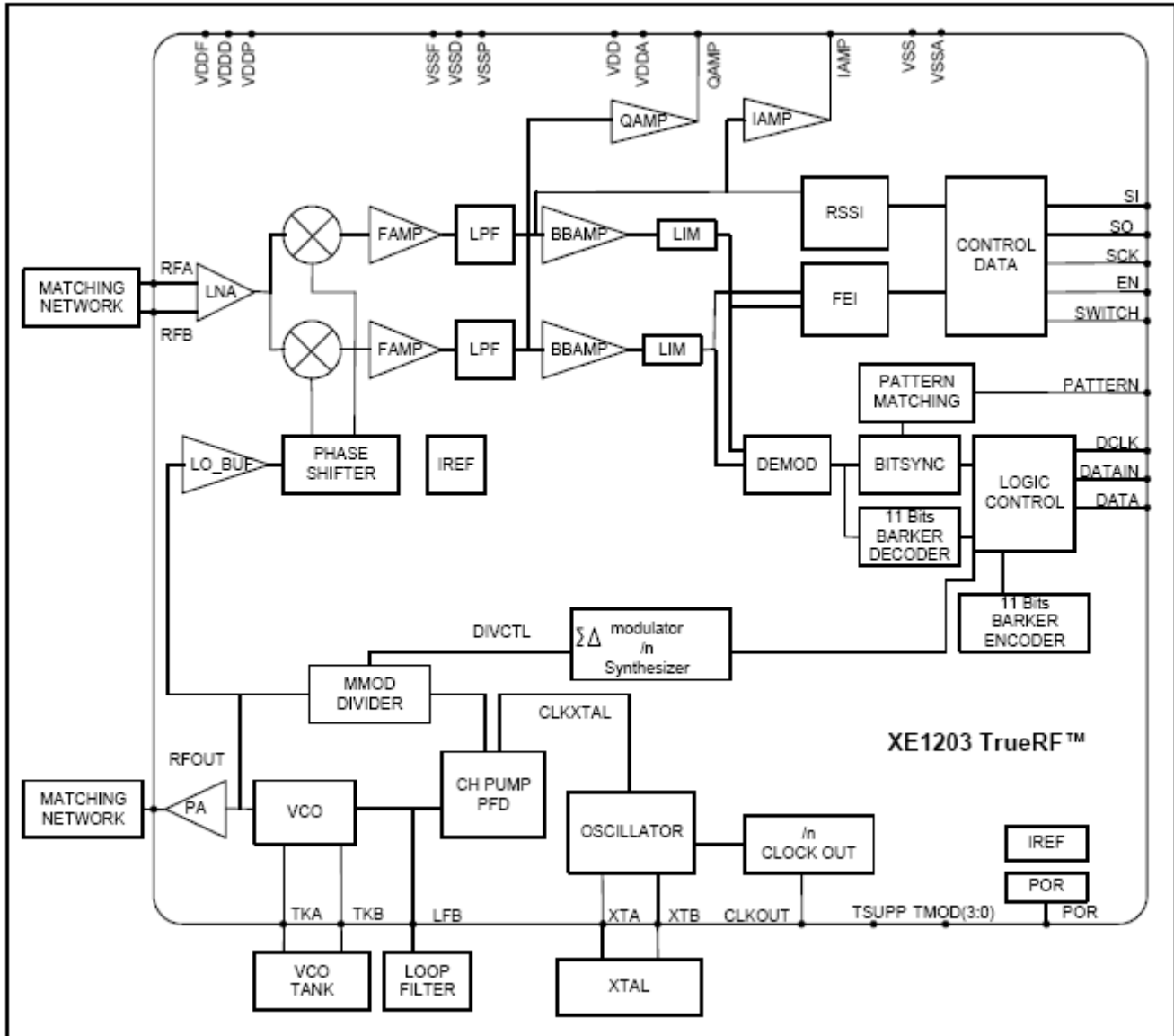

XE1203 Block Diagram

PIN ASSIGNMENT

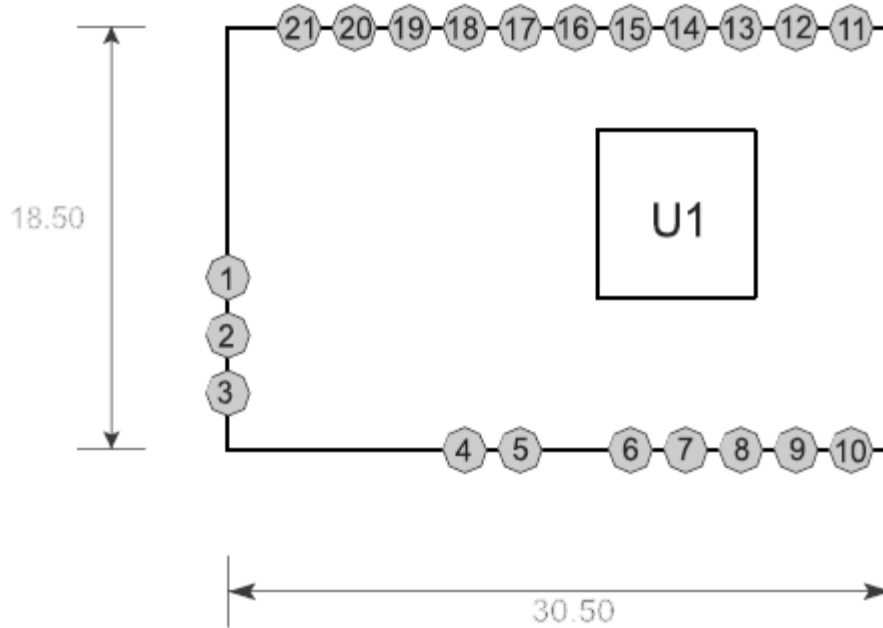

PAN Module Pin Locations

PIN FUNCTIONS

PIN	NAME	I/O	DESCRIPTION
1	GND	IN	Ground
2	RF	IN/OUT	RF input / output terminal
3	GND	IN	Ground
4	VDDP		Not Connected
5	VDD		Supply voltage 3.3 VDC
6	GND		Ground
7	VDD		Supply voltage 3.3 VDC
8	/EN	IN	3-wire interface communication enable signal
9	SWITCH	IN/OUT	Receiver or transmitter mode selection
10	GND	IN	Ground
11	GND	IN	Ground
12	SO	OUT	3-wire serial data interface: Data Out
13	SI	IN	3-wire serial data interface: Data In
14	SCK	IN	3-wire serial data interface: Data Clock
15	CLKOUT	OUT	Programmable reference clock output
16	DCLK	OUT	Receiver data clock
17	DATA	IN/OUT	Transmitter data input or receiver data output
18	DATAIN	IN	Transmitter data input
19	PATTERN	OUT	Receiver pattern recognition output
20	RX	IN	Antenna switch RX Select
21	TX	IN	Antenna switch TX select

Pin Assignment

ABSOLUTE MAXIMUM RATINGS

Symbol	Definition	Min	Max	Unit
VCC	Supply Voltage – Radio SOC	-0.3	3.9	VDC
Ts	Storage Temperature Range	-55	125	°C
TAP	Ambient Temperature with Power Applied	-40	85	°C
VLI	VDC to Logic Inputs	-0.3	VCC + 0.3	VDC
SDVD	Static Discharge Voltage Digital		>2000	VDC
SDVR	Static Discharge Voltage RF		>1100	VDC

These are stress ratings only. Exposure to stresses beyond these maximum ratings may cause permanent damage to, or affect the reliability of this module. Avoid using the module outside the recommended operating conditions defined below. This module is ESD sensitive and should be handled and/or used in accordance with proper ESD mitigation.

RECOMMENDED OPERATING CONDITIONS

Symbol	Description	Value			
		Min.	Typ.	Max	Unit
VCC	Supply Voltage	2.4	3.0	3.6	VDC
Toc	Operating Temperature Range	-40	25	85	°C
GND	Ground Voltage		0		VDC

RF AND ELECTRICAL CHARACTERISTICS

The table below gives the specifications of the PAN modules under the following conditions: Supply voltage VDD = 3.3V, temperature = 25°C, frequency deviation Δf = 5 kHz, Bit-rate = 4.8 kbit/s, base-band filter bandwidth BWSSB = 10 kHz, carrier frequency f_c = 434 MHz for the UGW3S4XESM33, f_c = 869 MHz for the UGW3S8XESM33 and f_c = 915 MHz for the UGW3S9XESM33, bit error rate BER = 0.1% (measured at the output of the bit synchronizer), antenna output matched at 50 Ω .

Symbol	Parameter	Conditions	Min	Typ	Max	Units
FSYNTH	Useable Synthesizer Frequency Range	UGW3S4XESM33	433		435	MHz
FSYNTH	Useable Synthesizer Frequency Range	UGW3S8XESM33	868		870	MHz
FSYNTH	Useable Synthesizer Frequency Range	UGW3S9XESM33	902		928	MHz
IDDSL	Sleep mode supply current			0.2	1	μ A
IDDST	Standby mode supply current	39 MHz running		0.85	1.1	mA
IDDRX	RX mode supply current			14	17	mA
IDDTX	TX mode supply current	PRF = 5 dBm		33	45	mA
IDDTX	TX mode supply current	PRF = 11dBm		62	75	mA
RFS	RF Sensitivity	DR = 4.8 kbPS / BER = 0.1%		-111	108	dBm
Δf	Frequency Deviation	Programmable	1	-	255	kHz
DR	Bit rate	Programmable	1.2	-	152.3	Kb/s
PRF	RF output power	Programmable. PRFMAX	8	11	-	dBm
TTX	Transmitter wake-up time	From oscillator enabled	-	200	250	μ s
TRX	Receiver baseband wake up time	From oscillator enabled	-	1.5	1.8	ms
FXTAL	Quartz oscillator wake up time		-	-	1	ms
FXTAL	Quartz oscillator frequency	Fundamental Mode		39		MHz
VIH	Digital input level high	% VDD	75	-	-	%
VIL	Digital input level low	% VDD	-	-	25	%
VOH	Digital output level high	% VDD	75	-	-	%
VOL	Digital output level low	% VDD	-	-	25	%

RF Characteristics

Name	Description	Min	Typ(25°C)	Max	Units
XO	Onboard Crystal		39		MHz
XO Offset	Crystal Tolerance		±10	±50	PPM
XO Drift	Crystal Drift		±5	±15	PPM/°C
SCLK	SPI Clock	not specified		2	MHz

Clock Specifications

AGENCY CERTIFICATIONS (PRE-SCAN)

//FCC Certification pending//

REGULATORY COMPLIANCE STATEMENT

The module has been pre-scanned against the relevant requirements of standards: EN 300 328, EN 301 489-17, FCC part 15 and Industry Canada RSS-210. The module is certified by the regulatory authorities in the USA and Canada and complies with the applicable essential requirements of the Radio & Telecommunication Terminal Equipment (R&TTE) directive in the EU. The module can thus be incorporated into products sold worldwide with little or no additional testing of the module itself. The end product must meet the appropriate technical requirements that apply to that product type but re-certification of the radio module is not required in the USA and Canada.

In the EU, the integrator is responsible for evaluating their product type per the essential performance requirements of the R&TTE directive (except those associated with the module), declaring compliance and then notifying the member states prior to marketing the product (because the module uses a frequency band that is not harmonized in the EU). It is the responsibility of the module integrator to obtain the necessary approval to sell products incorporating this module in other countries outside of North America and the EU. The report of measurements performed on the module in compliance with the FCC rules and EN standards can be used in these submittal (as the requirements in many other markets around the world are based in part or in whole on the standards prevalent in North America and the EU).

FUNCTIONAL OVERVIEW

PAN Module Functional Description

The PAN is a complete Radio Transceiver Module operating in the license free ISM (Industrial Scientific and Medical) UHF bands. The PAN modules come pre-tuned for 433, 868, or 915 MHz UHF bands. UHF bands offer superior range and Non-Line-of-Sight performance compared to 2.4 GHz systems. The device is suitable for applications which have to satisfy either the European (ETSI-300-220) or North American (FCC part 15) regulatory standards.

The module is based on the Semtech XE1203 transceiver. The PAN module offers high power, excellent sensitivity, wide-band FSK and DSSS encoding/decoding for robust long-range communication. The module is an SPI peripheral used with an external controller. The SPI control signals and data path are de-multiplexed for straight forward connections to independent host I/O ports. The XE1203 features a bit-synchronizer to clean up Rx data and recover the bit clock. The module is offered in an SMT for factor available in tape and reel packaging for automated assembly. Users will have to supply an external antenna via the 50 Ohm single-ended RF interface to motherboard. Pan offers designers excellent link budget for wideband systems where range and robust signaling are critical.

XE1203 Functional Description

The XE1203F is a direct conversion (Zero-IF) half-duplex data transceiver. The circuit operates in three different ISM frequency bands (433 MHz, 868 MHz and 915 MHz) and uses 2-level FSK modulation/demodulation to provide a complete transmission link. It is capable of operating at data rates between 1.2 and 152.3 kbit/s, making it ideally suited for applications where high data rates are required.

It also supports the Konnex (KNX) standard where the bit rate is 32.7 kbit/s. The device includes dedicated Barker encoder/decoder hardware that may be activated to modulate/demodulate the transmitted signal to reduce in-band interferences.

The XE1203F is a highly programmable device – channel, bit rate, frequency deviation, output power, base band filter bandwidth, sensitivity vs. linearity, RSSI feature, and many other parameters – which makes it extremely flexible, to meet a large number of end user requirements.

The main functional blocks of the XE1203F are the receiver, the transmitter, the frequency synthesizer and some service blocks. The device also includes a series of configuration and status

registers. In a typical application, the XE1203F is programmed by a microcontroller via the 3-wire serial bus SI, SO, SCK to write to and read from these registers.

The Receiver converts the incoming 2-level FSK modulated signal into a synchronized bit stream. The Transmitter performs the modulation of the carrier by an input bit stream and the transmission of the modulated signal.

The Frequency Synthesizer generates the local oscillator (LO) signal for the receiver section as well as the continuous phase FSK modulated signal for the transmitter section.

The Service Blocks provide the internal voltage and current sources and provide all the necessary functions for the circuit to work properly.

The Configuration Registers are a set of variable-length registers that are used to store various settings to operate the XE1203F transceiver circuit. They are listed below in the table below. These registers are accessed in write or read mode through the 3-wire serial bus.

Name	Description
ConfigSwitch	1-bit data to switch between 2 sets of user-predefined SWParam Configuration Registers
RTPParam	Receiver and transmitter parameters
FSPParam	LO, Bitrate, Deviation and other frequency parameters
SWParam	2 sets of user-predefined configuration registers
DataOut	Status register which can be read through the 3-wire serial interface
ADParam	Additional parameters
Pattern	Reference pattern for the "pattern recognition" feature

Control Registers

DIGITAL INTERFACE

Serial Control Interface

A 3-wire bi-directional bus (SCK, SI, SO) is used to control the DP1203. The output signal, SO, is provided by the DP1203 in opposition to the SCK and SI which need to be provided by the external application as an 8-bit microcontroller. An access Read or Write with the XE1203 is possible only when the enable signal is active (active LOW).

For more information about the 3-wire bus, please refer to the XE1203 datasheet chapter; Interface definition, principles of operation.

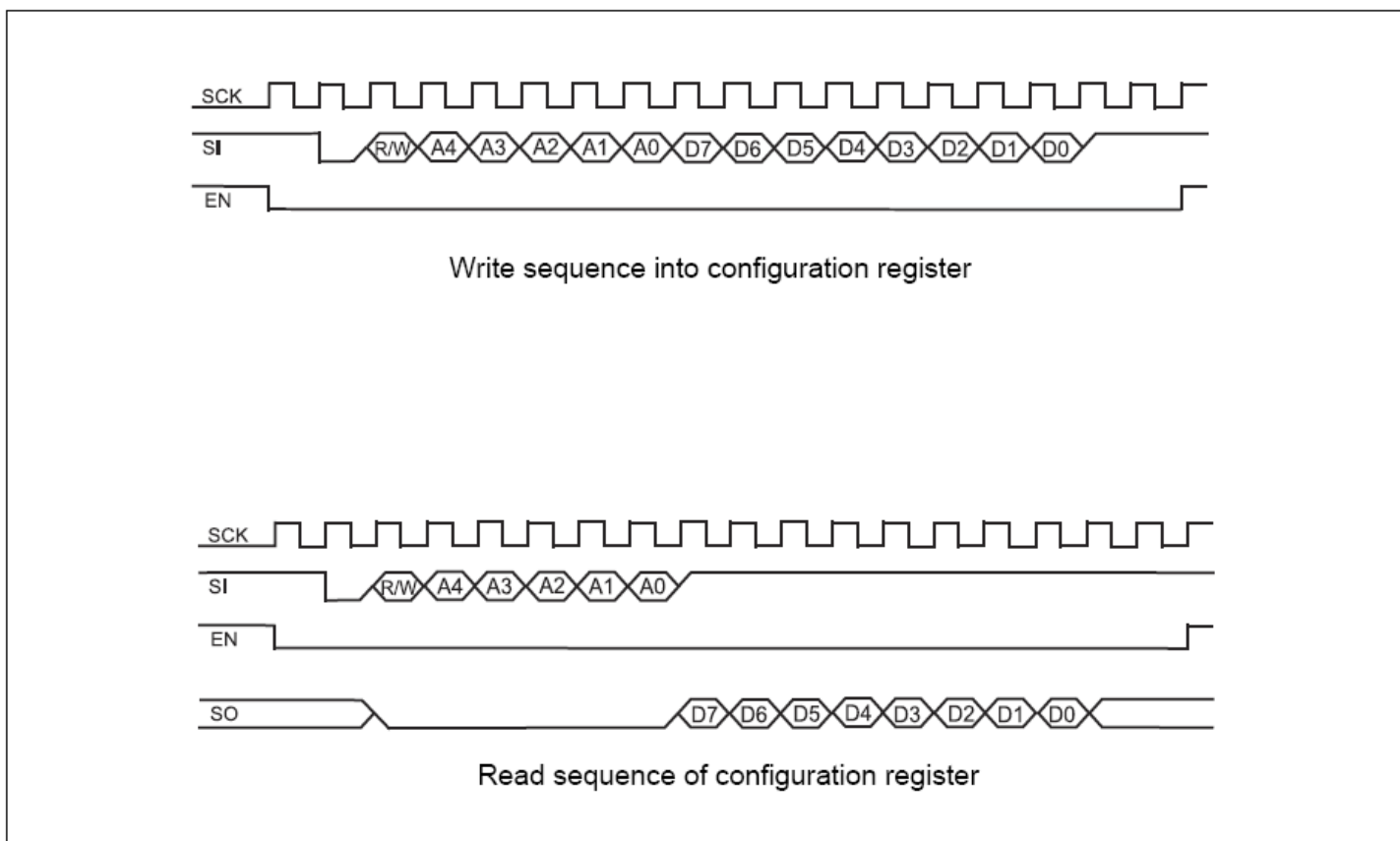

SPI Read and Write Sequences

Control Registers

The XE1203F has several operating modes and configuration parameters which can be programmed by the user or the application. In addition, status information may be read from the circuit. Some of the operating modes, the status information and the configuration parameters are stored in a series of internal Configuration and Status Registers that can be accessed by the microcontroller through the 3-wire serial interface.

There are seven variable Configuration and Status Registers, as listed below.

Name	Description	Size (bits)	Address (binary format)
ConfigSwitch	1-bit data to switch between 2 sets of user-predefined SWParam Configuration Registers	1 x 1	0
RTPParam	Receiver and transmitter parameters	2 x 8	00001 -00010
FSPParam	LO, Bitrate, Deviation and other frequency parameters	3 x 8	00011 -00101
SWParam	2 sets of user-predefined configuration registers	6 x 8	00110 -01011
DataOut	Status register which can be read through the 3-wire serial interface	2 x 8	01100 -01101
ADParam	Additional parameters	5 x 8	01110 -10010
Pattern	Reference pattern for the "pattern recognition" feature	4 x 8	10011 -10110

Configuration and Status Registers

All the bits that are referred to as "reserved" in this section should be set to "0" during write operations.

ConfigSwitch

When operating the XE1203F, it might be useful to quickly switch between two pre-defined operating modes, to save time and traffic on the 3-wire serial interface bus. This may occur when the XE1203F is required to switch quickly between receive and transmit mode, when it has to operate on two different carrier frequencies, or when it has to switch between the high linearity mode B and the high sensitivity mode A. For that purpose, the five Depending on the ConfigSwitch 1-bit Register or the input level at the SWITCH pin, the XE1203F transceiver will use either the SWParam configuration set#1 or the set #2. If the RTPParam_Switch_ext configuration parameter is low, then the SWParam configuration set is selected by the ConfigSwitch parameter – set#1 if ConfigSwitch is "0", set#2 if ConfigSwitch is "1". If the RTPParam_Switch_ext configuration parameter is high, then the SWParam configuration set is selected by the SWITCH pin – set#1 if SWITCH is low, set#2 if SWITCH is high.

ConfigSwitch Register	SWITCH pin	RTParam_switch_ext configuration parameter	SWParam configuration set selected
0	SWITCH is an output: '1' in transmitter mode '0' in the other modes	0	Set #1: SWParam_mode_1 SWParam_Power_1 SWParam_Rmode_1 SWParam_t_delsig_in_1 SWParam_freq_1
1	SWITCH is an output: '1' in transmitter mode '0' in the other modes	0	Set #2: SWParam_mode_2 SWParam_Power_2 SWParam_Rmode_2 SWParam_t_delsig_in_2 SWParam_freq_2
X	0	1	Set #1: SWParam_mode_1 SWParam_Power_1 SWParam_Rmode_1 SWParam_t_delsig_in_1 SWParam_freq_1
X	1	1	Set #2: SWParam_mode_2 SWParam_Power_2 SWParam_Rmode_2 SWParam_t_delsig_in_2 SWParam_freq_2

ConfigSwitch

By default the configuration set#1 is used and register RTParam_switch_ext is set to '0'. Note that a new value of the ConfigSwitch register or at the SWITCH pin should be modified when the EN signal is low. The actual switch to the newly selected set of SWParam register will be applied to the transceiver on the next rising edge of the EN signal.

RTPParam

Name	Bits	Address	Description
RTPParam_Bitsync	7	00001	Bit synchronizer 0 -> disabled 1 -> enabled
RTPParam_Barker	6	00001	BARKER coder/decoder: 0 -> disabled 1 -> enabled
RTPParam_Rssi	5	00001	RSSI function: 0 -> disabled 1 -> enabled
RTPParam_Rssir	4	00001	RSSI range: 0 -> low range (see 3.2.2) 1 -> high range (see 3.2.2)
RTPParam_Fei	3	00001	FEI function: 0 -> disabled 1-> enabled
RTPParam_BW	2	00001	Baseband filter bandwidth (BBW) 0 -> 200 kHz (DSB) 1 -> 600 kHz (DSB)
RTPParam_Osc	1	00001	Reference frequency source: 0 -> internal crystal oscillator 1 -> external source
RTPParam_Clkout	0	00001	CLKOUT -Reference frequency divided by 4,8,16,or 32: 0 -> disabled 1 -> enabled
RTPParam_Stair	7	00010	Transmitter pre-filter rise/fall time: 0 -> 10% of bit duration 1 -> 20% of bit duration
RTPParam_Filter	6	00010	Pre-filtering of the bit stream in transmitter mode 0 -> no filtering 1 -> filtering The filtering function is available only for the following bit rates and frequency deviations: FSPanam_Br = "1111110" -> BR = 1200 bit/s FSPanam_Br = "0111111" -> BR = 24
RTPParam_Modul	5	00010	Transmitter modulation: 0 -> enabled 1 -> disabled
RTPParam_IQAMP	4	00010	I&Q amplifiers: 0 -> disabled 1 -> enabled
RTPParam_Switch_ext	3	00010	SWParam configuration set selection: 0 -> configuration set defined by ConfigSwitch. SWITCH is an output 1 -> configuration set defined by the pin SWITCH. SWITCH is an input
RTPParam_Pattern	2	00010	Pattern recognition function: 0 -> disabled 1 -> enabled
RTPParam_Band	1-0	00010	Frequency band: 01 -> 433 – 435 MHz 10 -> 868 – 870 MHz 11 -> 902 – 928 MHz

RTPParam

FSParam

Name	Bits	Address	Description
FSParam_Dev	7-0	00011	Frequency deviation Δf : $\Delta f = \text{int}(\text{FSParan_Dev}) * 1 \text{ kHz}$, where $\text{int}(x) =$ integer value of the binary representation of x . Example: 00000001 -> $\Delta f = 1 \text{ kHz}$ 11111111 -> $\Delta f = 255 \text{ kHz}$
FSParam_Change_Osr	7	00100	OSR Mode (Oversampling Rate mode): 0 -> default Bit rate defined by FSParam_Br 1 -> variable OSR
FSParam_Br	6-0	00100	Bit rate (when "FSParam_Change_Osr" = "0"): $\text{Br} = 152340 / (\text{int}(\text{FSParam_Br}) + 1)$, where $\text{int}(x) =$ integer value of the binary representation of x . Example: 0000000 -> $\text{Br} = 152.34 \text{ kbit/s}$ 1111111 -> $\text{Br} = 1.19 \text{ kbit/s}$ 0000100 -> $\text{Br} = 32.7 \text{ kbit/s}$ used in Konnex mode
FSParam_OSR	7-0	00101	Define BR in terms of FSParam_BR and FS_Param_OSR: FSParam_OSR = "00011101" and FSParam_Change_Osr = '1' for Konnex standard

FSParam

SWParam

Switch_ext Bit 3, Address 00010	Chip_config Bit 0, Address 00000	SWITCH (pin)	Mode selected
0	0	Set in Output -"1" DP1203 is in transmitter -"0" DP1203 other modes	Mode 1 Bit 7-6, Address 00110 -0 0 : sleep mode -0 1 : standby mode -1 0 : receiver mode -1 1 : transmitter mode
0	1	Set in Output -"1" DP1203 is in transmitter -"0" DP1203 other modes	Mode 2 Bit 7-6, Address 01001 -0 0 : sleep mode -0 1 : standby mode -1 0 : receiver mode -1 1 : transmitter mode
1	X	0	Mode 1 Bit 7-6, Address 00110 -0 0 : sleep mode -0 1 : standby mode -1 0 : receiver mode -1 1 : transmitter mode
1	X	1	Mode 2 Bit 7-6, Address 01001 -0 0 : sleep mode -0 1 : standby mode -1 0 : receiver mode -1 1 : transmitter mode

SWParam

SWParam_Freq_1 MSB (Byte address 00111) or SWParam_Freq_2 MSB (Byte address 01010) Bit 7 Bit 0	SWParam_Freq_1 LSB (Byte address 01000) or SWParam_Freq_1 LSB (Byte address 01011) Bit 7 Bit 0	Resulting LO setting Note: reference frequency = 39.0 MHz
00000000	00000000	F0, where F0 depends on the selected frequency band (see RTParam_Band) F0 = 434.0 MHz for the 433-435 MHz band F0 = 869.0 MHz for the 868-870 MHz band F0 = 915.0 MHz for the 902-928 MHz band
00000000	00000001	F0 + 500 Hz
00000000	00000010	F0 + 2 * 500 Hz
11111111	11111111	F0 - 500 Hz
11111111	11111110	F0 - 2 * 500 Hz

Examples of LO frequency settings

DataOut

Name	Bits	Address	Description
DataOut_Rssi	7-6	01100	RSSI output: 0 0 -> lowest level, \leq VTNR1 0 1 -> 2nd level, VTNR1<RSSI level \leq VTNR2 1 0 -> 3rd level, VTNR2<RSSI level \leq VTNR3 1 1 -> highest level, VTNR3<RSSI level
RESERVED	5-4	01100	RESERVED
DataOut_MSB_fei	3-0	01100	Fei output (MSB)
DataOut_LSB_fei	7-0	01101	Fei output (LSB) Ferror = $(Br/8)*int(DataOut_MSB_fei \& DataOut_LSB_fei)$ Where $int(x)$ = integer value of the binary representation of x

DataOut

ADParam

Name	Bits	Address	Description
ADParam_Psize	7-6	01110	Size of reference pattern recognition word: 0 0 -> 8 bits 0 1 -> 16 bits 1 0 -> 24 bits 1 1 -> 32 bits
ADParam_Ptol	5-4	01110	Number of tolerated errors for the pattern recognition: 00 -> 0 error 01 -> 1 error 10 -> 2 errors 11 -> 3 errors
ADParam_Clk_freq	3-2	01110	CLKOUT frequency (if enabled) 00 -> 1.22 MHz (div ratio :32) 01 -> 2.44 MHz (div ratio :16) 10 -> 4.87 MHz (div ratio :8) 11 -> 9.75 MHz (div ratio :4)
ADParam_Invert	1	01110	Inversion of Rx output data: 0 -> disabled 1 -> enabled
ADParam_RegBW	0	01110	Baseband filter bandwidth calibration: 0 -> enabled 1 -> disabled
ADParam_Regfreq	7	01111	Period of baseband filter bandwidth calibration whilst Rx enabled: 0 -> only at start-up of the receiver 1 -> 60 seconds (default mode) or 7 seconds (test mode)
ADParam_Regcond	6	01111	Baseband filter bandwidth calibration as a function of selected bandwidth: 0 -> calibration restarted each time the bandwidth is changed 1 -> no calibration when the bandwidth is changed
ADParam_Xsel	5	01111	Selection of the XOSC load capacitance mode: 0 -> CL+C0 = 15 pF 1 -> CL+C0 = 11 pF, low current mode
ADParam_Resxosc	4-1	01111	Selection of the value of the shunt resistor across ports TKA and TKB for a third overtone XTAL operation: 0000 -> 3800 kΩ 0001 -> 2.55 kΩ 0010 -> 4.65 kΩ 0011 -> 1.78 kΩ 0100 -> 8.79 kΩ 0101 -> 2.07 kΩ 0110 -> 3.22 kΩ 0111 -> 1.56 kΩ 1000 -> 16.55 kΩ 100
ADParam_enable_konnex	0	01111	Konnex mode: 0 -> disabled 1 -> enabled
ADParam_Chge_thres	7	10000	Enable programming of the sync and acquisition thresholds: 0 -> threshold are hard-coded and sync-loss counter is 50 bits 1 -> threshold are defined by BParam_Sync_thres and BParam_Trac_thres Sync loss counter is variable and defined by ADParam_Sync_loss
ADParam_Sync_thres	6-0	10000	Barker mode sync acquisition threshold
ADParam_disable_data_bidir	7	10001	DATA port bidirectional mode: 0 -> enabled 1 -> disabled: DATA = output, DATAIN = input
ADParam_Trac_thres	6-0	10001	Threshold for tracking Barker mode
ADParam_Fix_bsync	7	10010	bit synchronizer configuration: 0-> default configuration 1-> high-interference environment
ADParam_Sync_loss	6-0	10010	Number of bits before sync loss detection for Barker decoding algorithm

ADParam

PATParam

This register holds the user supplied reference pattern of 8, 16, 24, or 32 bits (see the ADParam_Psize parameter). The first byte of this pattern is always stored in the byte at address A[4:0] = 10011. If used, the 2nd byte is stored at address A[4:0] = 10100, the 3rd byte at address A[4:0] = 10101, and finally the 4th byte at address A[4:0] = 01011. The MSB bit of the reference pattern is always bit 7 of address 10011.

Comparing the demodulated data, the first bit received of the last word is compared with bit 7 (the MSB) of byte address 10011. The last bit received is compared with bit 0 (the LSB) in the Pattern register.

Name	Bits	Byte Address	Description
PATParam_Pattern	7-0	10011	1st byte of the reference pattern
		10100	2nd byte
		10101	3rd byte
		10110	4th byte

PATParam

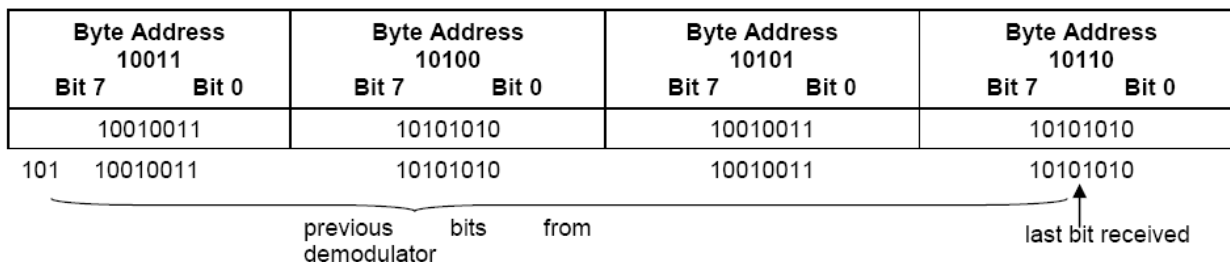

Pattern recognition with a 32-bit pattern

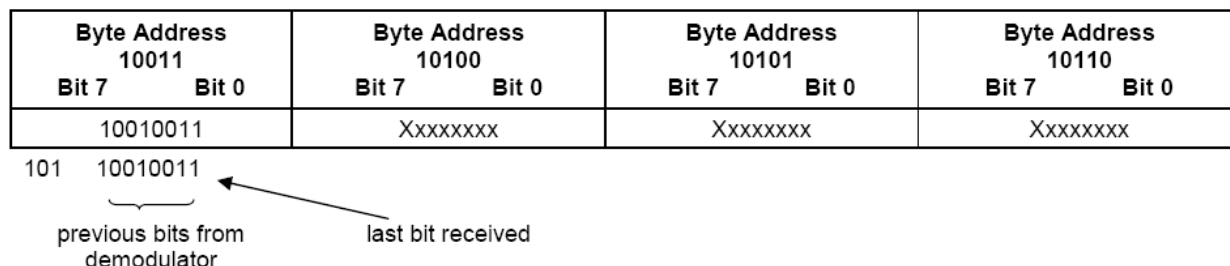

Pattern recognition with an 8-bit pattern

TParam

Some settings in this 9-byte register can be used to have access to additional configurations of the circuit. These settings are described in the table below:

Name	Bits	Byte Address	Description
TParam_BW	3	10111	Baseband filter bandwidth (DSB): 0 -> default values defined by RTParam_BW (200 and 600 kHz) 1 -> 300kHz
TParam_HPF	1-0	10111	SSB cut-off frequency of the HPF stage (for cancellation of DC and low-frequency offsets in the baseband circuit): 00 -> 4.3 kHz 01 -> 8.7 kHz 10 -> 17.3 kHz 11 -> 34.6 kHz

OPERATING MODES

The PAN Module has 2 main operating modes (Mode 1, Mode 2); each mode is subdivided into 4 modes illustrated in the table below. The switching between Mode1 and Mode 2 can be done either through the 3-wire bus (Chip_config register) or by using the pin SWITCH. The selection depends on the Switch_ext which is a XE1203 register.

Switch_ext Bit 3, Address 00010	Chip_config Bit 0, Address 00000	SWITCH (pin)	Mode selected
0	0	Set in Output -"1" DP1203 is in transmitter -"0" DP1203 other modes	Mode 1 Bit 7-6, Address 00110 -0 0 : sleep mode -0 1 : standby mode -1 0 : receiver mode -1 1 : transmitter mode
0	1	Set in Output -"1" DP1203 is in transmitter -"0" DP1203 other modes	Mode 2 Bit 7-6, Address 01001 -0 0 : sleep mode -0 1 : standby mode -1 0 : receiver mode -1 1 : transmitter mode
1	X	0	Mode 1 Bit 7-6, Address 00110 -0 0 : sleep mode -0 1 : standby mode -1 0 : receiver mode -1 1 : transmitter mode
1	X	1	Mode 2 Bit 7-6, Address 01001 -0 0 : sleep mode -0 1 : standby mode -1 0 : receiver mode -1 1 : transmitter mode

Operating Modes

Tx RX Switching

The drop-in module DP1203 is able to switch between any configuration by using the 3-wire bus or by using the pin SWITCH. This section describes the switching sequence from Mode 1 to Mode 2.

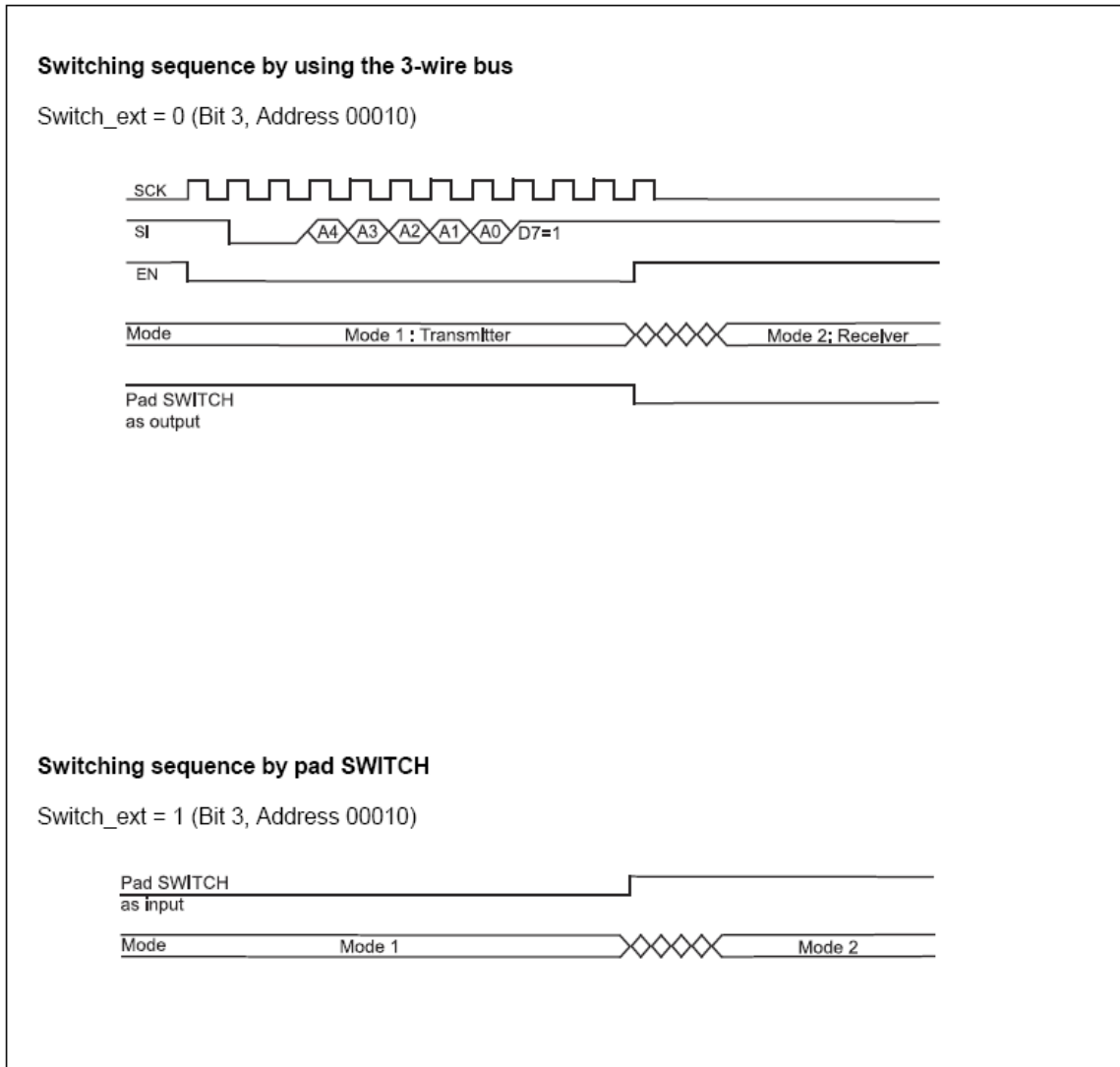

Standard Tx/Rx Switching Sequence

TYPICAL APPLICATION CIRCUIT

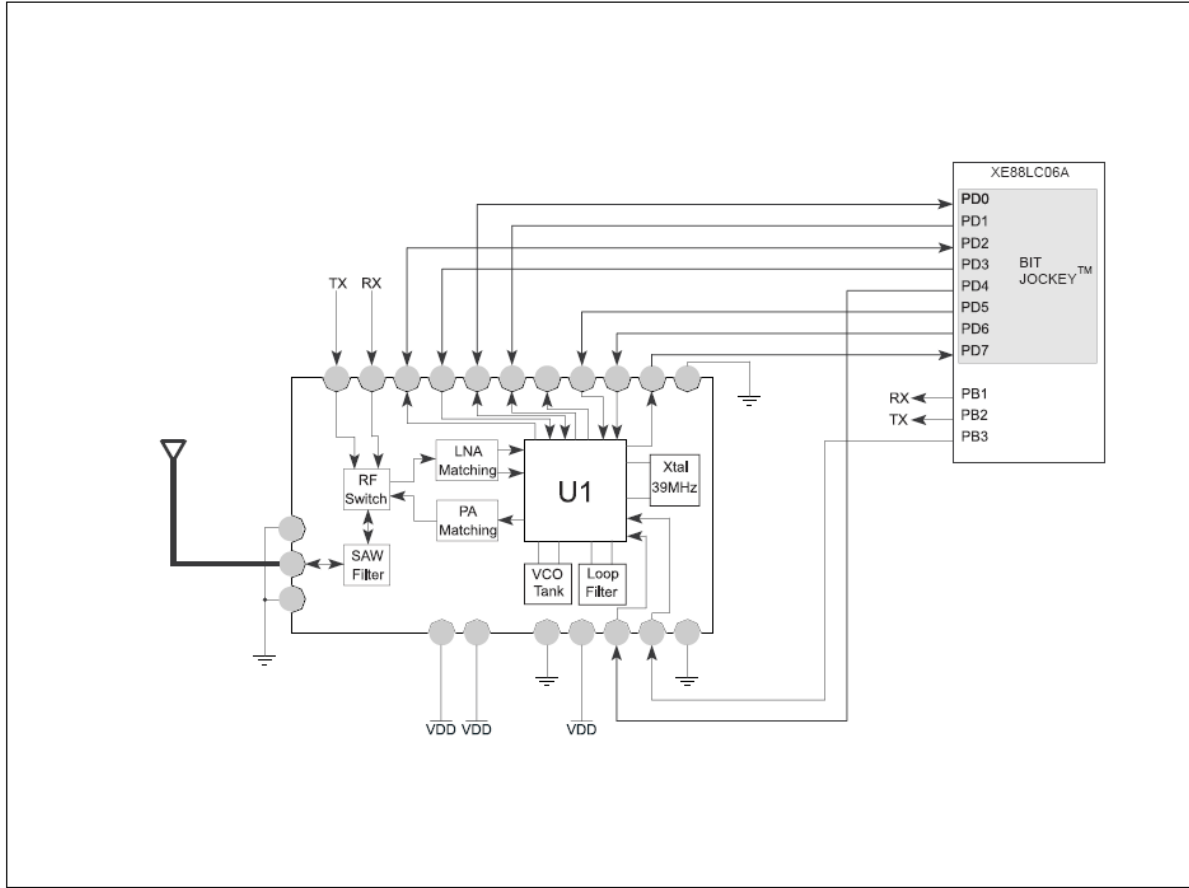

Typical microcontroller interface

MECHANICAL DRAWINGS

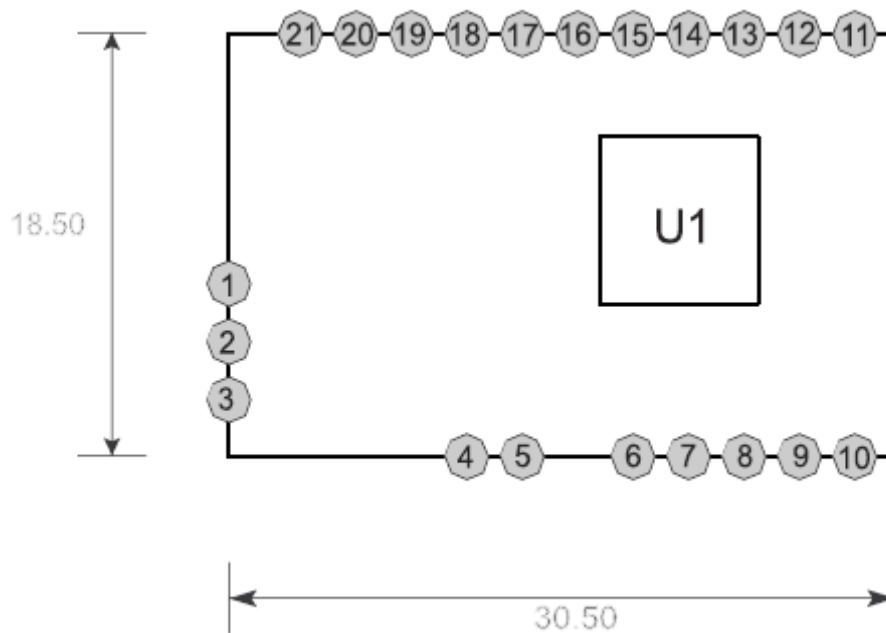

Module Dimensions and Pin Location
X=30.5 Y=18.5 Z=4.6 mm

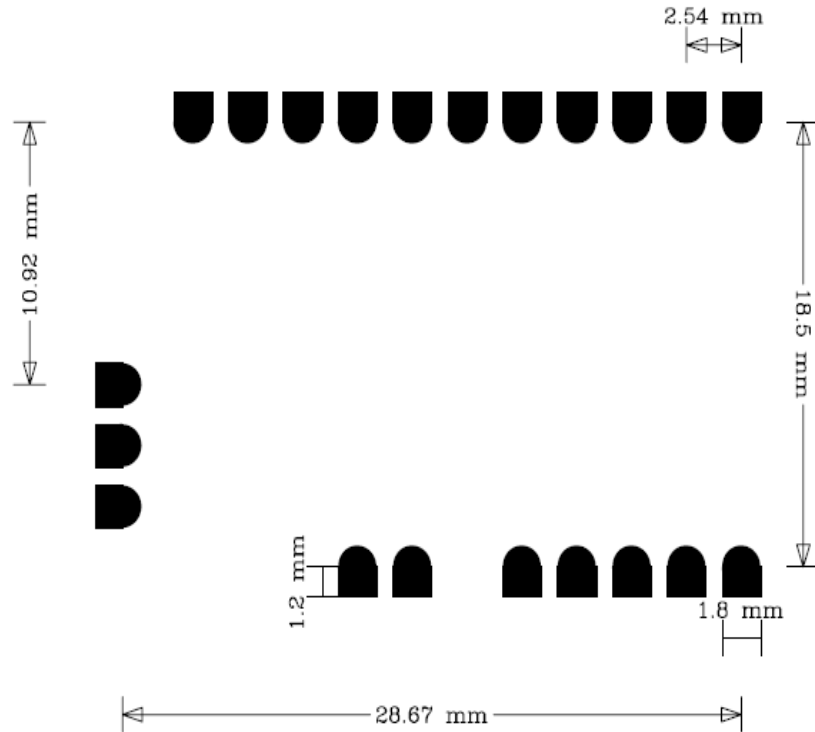

Recommended PCB Layout

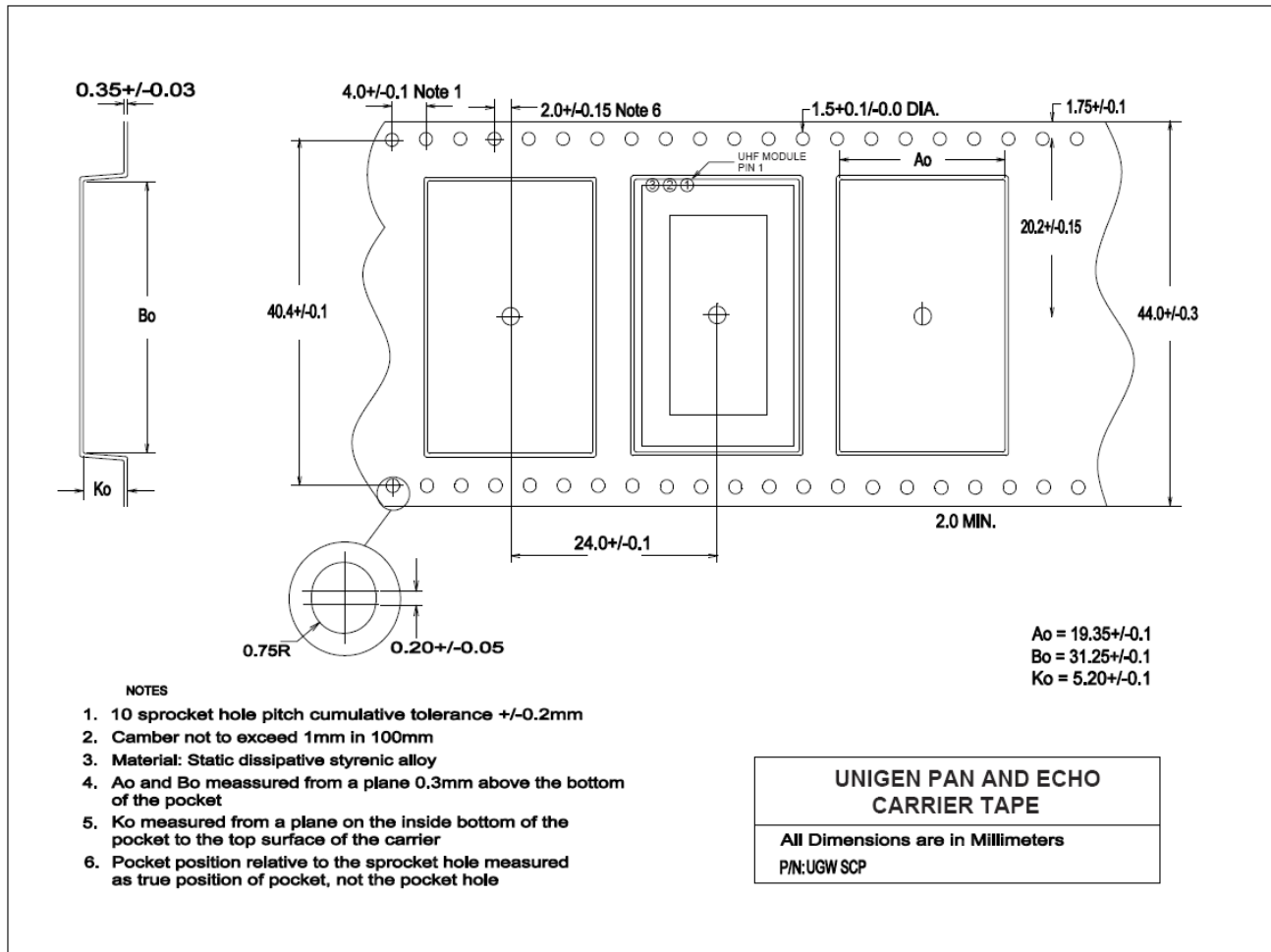

Tape and Reel Dimensions

PRODUCTION GUIDELINES

- PAN modules that are formed into a hybrid surface mount package which allows both manual and automated placement.
- PAN modules contain discrete components, therefore the assembly procedures utilized by automated or manual techniques are critical for the performance after installation on the end users product.
- Unigen recommends proper ESD procedures.

Manual Assembly

- The primary mounting surface for the module is located on the bottom pad surface.
- Castellations have been provided that run perpendicular to the pad surface beneath. This design allows for proper heat transfer and solder wicking to the bottom side.
- It is recommended that the user carefully align and tack one corner of the module then move sequentially around the module.
- The end user layout pads should extend out slightly from the module to allow a fine tip soldering iron to heat the pad and castellation simultaneously.
- Use a fine point conical tip to heat the modules castellation and board pad simultaneously.
- Apply .020 solder wire to the pad where the castellation contacts. The solder will wick properly to the underlying surface providing a secure electrical connection.

Automated Assembly

- Modules have been designed to be compatible with techniques utilized in an automated process.
- Due to the complexity of the module, additional attention is required in comparison to other component types.
- The reflow temperature profile is a critical point for creating a consistent solder connection.
- Any shock that may be applied during the reflow movement process should be avoided.
- If a shock is applied during the liquefied state of reflow, the components may shift causing malfunction of the module.

Washing

- If modules are assembled with a water soluble process special attention to cleaning will be necessary.
- All flux residue should be removed with deionized water to ensure performance, as well as reduce the potential of ionic contamination and corrosive activity.
- Modules which have been washed must be completely dry before power-up or testing. Overnight bake is recommended.
- Ultrasonic cleaning systems should not be used.
- Proper support during wash is necessary to eliminate any mechanical stress which could damage components on the module.

Solder Profiles

Preliminary information subject to change.

Recommended Soldering Parameters (RoHS Compliant)		
Printing/Dispensing	Reflow Profile	Note
<ul style="list-style-type: none"> Stencil: 0.006 inch (6 mil) Squeegee: Metal (recommended) 	<ul style="list-style-type: none"> Ramp @ 1.0 – 2.0°C/sec to 130°C Slow ramp from 130°C to 180°C for 90- 120 seconds Ramp @ 0.5- 2°C /sec to peak temperature 230°C to 250°C TAL for 40- 80 seconds Ramp down to R.T. @ 1- 3°C/sec 	<p>Please note that the reflow profiles listed are guidelines only and adjustments may be necessary to ensure proper wetting of the solder.</p>

Recommended Soldering Parameters (non-RoHS Compliant)		
Printing/Dispensing	Reflow Profile	Note
<ul style="list-style-type: none"> Stencil: 0.006 inch (6 mil) Squeegee: Metal (recommended) 	<ul style="list-style-type: none"> Straight ramp up profile preferred Ramp up from ambient temp. to peak temp. of 210°C to 225°C @ 1°C /sec TAL (Time Above Liquidus) = 45 to 75 seconds Ramp down to R.T. @ 1- 3°C/sec 	<p>Please note that the reflow profiles listed are guidelines only and adjustments may be necessary to ensure proper wetting of the solder.</p>



Solutions for a Real Time World

PAN 433/868/902 MHz - UGW3S

Datasheet

REFERENCE DOCUMENTATION

Semtech DP1203 Datasheet Rev 1 April 2006
Semtech XE1203 Datasheet Rev 1 March 2007

CONTACT INFORMATION

CORPORATE HEADQUARTERS

Unigen Corporation
45388 Warm Springs Boulevard
Fremont, CA 94539

Telephone: 1 (510) 688-2088
Fax: 1 (510) 668-2788
Email: Support@unigen.com
Web: www.unigen.com
Toll Free: 1 (800) 826-0808