

THIS DRAWING IS UNPUBLISHED. RELEASED FOR PUBLICATION AUGUST, 2006.

© COPYRIGHT 2006 BY TYCO ELECTRONICS CORPORATION. ALL RIGHTS RESERVED.

LOC	DIST	REVISIONS					
E	B	P	LTR	DESCRIPTION	DATE	DWN	APVD
		B		ECR-06-017552	02AUG06	JMS	FWK

NOTES:

- 1 PACK IN ACCORDANCE WITH AMP SPEC 107-3275
- 2 100 TRAY PACK IN ACCORDANCE WITH AMP SPEC 107-3275
- 3 Au PLATING
- 4 Ni PLATING
- 5 THIS ITEM MUST BE WHITE
- 6 **ELECTRICAL CHARACTERISTICS**
 FREQUENCY RANGE: DC - 11 GHz
 NOMINAL IMPEDANCE: 50 Ohm
 INSULATION RESISTANCE: 5000 MOhm
 WORKING VOLTAGE: 1000 Volts RMS at Sea Level
 DIELECTRIC WITHSTAND VOLTAGE: 2500 Volts RMS Max
 CONTACT RESISTANCE:
 CENTRE CONTACT: 1.00 mOhm Max
 OUTER CONTACT: 1.00 mOhm Max
 VSWR @ 4GHz: 1.30:1 Max
 INSERTION LOSS dB @ x 4 GHz: 0.30 Max
- 7 **MECHANICAL CHARACTERISTICS**
 COUPLING NUT RETENTION FORCE: N/A
 CABLE RETENTION FORCE: 170N Min
 CLAMP NUT RECOMMENDED TORQUE: 4N
 DURABILITY: 500 Cycles Min
- 8 **ENVIRONMENTAL CHARACTERISTICS**
 OPERATING TEMPERATURE: -65 to +165 DegC
- 9 FOR TECHNICAL DATA REFER TO YOUR LOCAL TYCO ELECTRONICS SALES OFFICE.
- 10 ALL DIMENSIONS ARE NOMINAL FOR REFERENCE ONLY UNLESS OTHERWISE STATED.

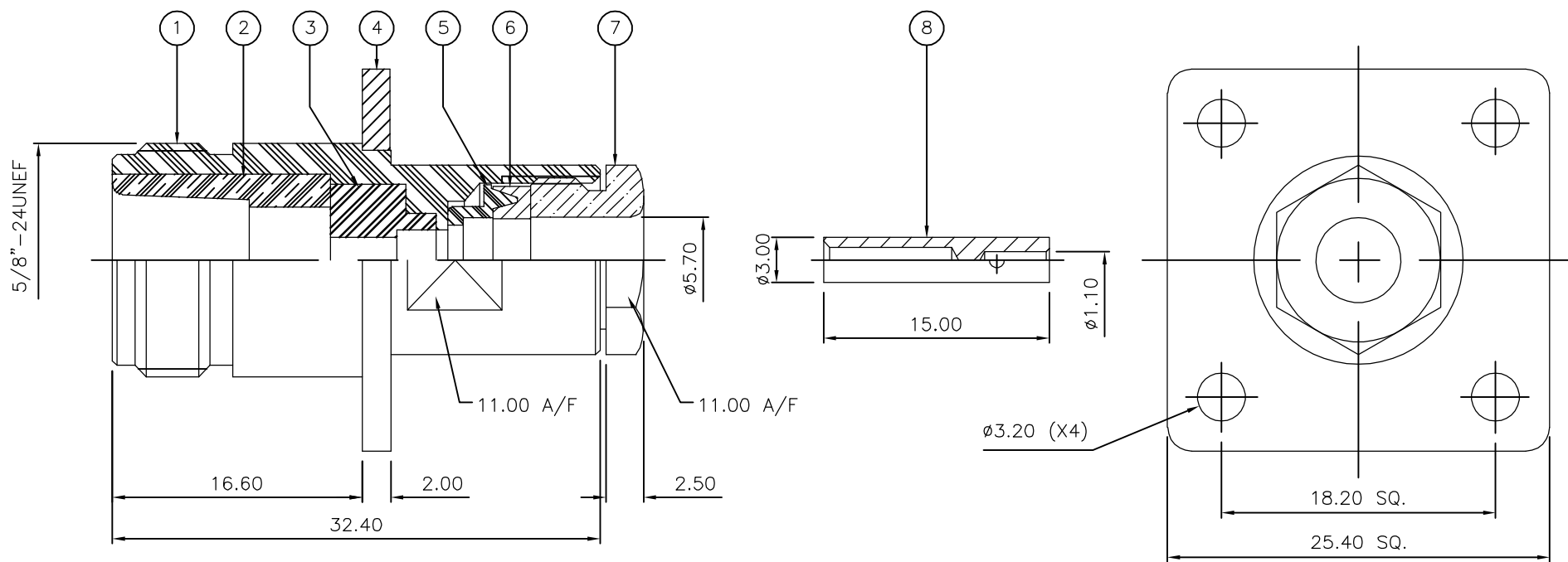

RECOMMENDED CABLE STRIPPING DIM'S

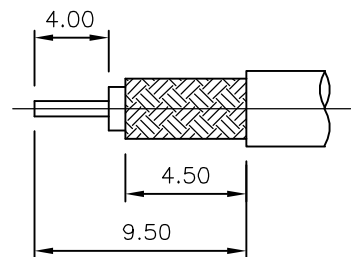

QTY	QTY PER ASSY	MATERIAL	DESCRIPTION	ITEM
1	1	BRASS	CONTACT	8
1	1	BRASS	CLAMP NUT	7
1	1	SILICONE RUBBER	GASKET	6
1	1	BRASS	SLEEVE	5
1	1	BRASS	FLANGE	4
1	1	PTFE	INSULATION	3
1	1	BRASS	CHASSIS	2
1	1	BRASS	BODY	1
6--0	1--0	MATERIAL	DESCRIPTION	ITEM

THIS DRAWING IS A CONTROLLED DOCUMENT.		DWN J.SANDWELL 02AUG06	Tyco Electronics Corporation Bideford EX39 4HE	
DIMENSIONS: mm		CHK S.PARLOW 02AUG06		
TOLERANCES UNLESS OTHERWISE SPECIFIED:		APVD F.WHEELER-KING 02AUG06	NAME	
0 PLC ± -		PRODUCT SPEC	TYPE 'N' PANEL JACK SOLDER 50 OHM	
1 PLC ± -		APPLICATION SPEC	RG55B/U, 142B/U, 223/U, 400/U, URM301, KX23	
2 PLC ± -		411-3254	SIZE A3	CAGE CODE 00779
3 PLC ± -		WEIGHT -	DRAWING NO C-1478191	RESTRICTED TO -
4 PLC ± -		SEE TABLE	SCALE NTS SHEET 1 OF 1 REV B	
ANGLES ± -		CUSTOMER DRAWING		
FINISH -				