

THIS DRAWING IS UNPUBLISHED. RELEASED FOR PUBLICATION AUGUST, 2006.

© COPYRIGHT 2006 BY TYCO ELECTRONICS CORPORATION. ALL RIGHTS RESERVED.

LOC	DIST	REVISIONS					
E	B	P	LTR	DESCRIPTION	DATE	DWN	APVD
		B		ECR-06-017552	01AUG06	JMS	FWK

NOTES:

- 1 PACK IN ACCORDANCE WITH AMP SPEC 107-3275
- 2 100 TRAY PACK IN ACCORDANCE WITH AMP SPEC 107-3275
- 3 Ag PLATING
- 4 THIS ITEM MUST BE WHITE
- 5 HAND TOOL : 9-1478240-0
- 6 DIE SET : 9-1478242-0
- 7 ELECTRICAL CHARACTERISTICS

FREQUENCY RANGE:	DC - 11 GHz
NOMINAL IMPEDANCE:	50 Ohm
INSULATION RESISTANCE:	5000 MOhm
WORKING VOLTAGE:	1000 Volts RMS at Sea Level
DIELECTRIC WITHSTAND VOLTAGE:	2500 Volts RMS Max
CONTACT RESISTANCE:	
CENTRE CONTACT:	1.00 mOhm Max
OUTER CONTACT:	1.00 mOhm Max
VSWR @ 4GHz:	1.30:1 Max
INSERTION LOSS dB @ x 4 GHz:	0.30 Max
- 8 MECHANICAL CHARACTERISTICS

COUPLING NUT RETENTION FORCE:	445N Min
CABLE RETENTION FORCE:	170N Min
DURABILITY:	500 Cycles Min
- 9 ENVIRONMENTAL CHARACTERISTICS

OPERATING TEMPERATURE:	-65 to +165 DegC
------------------------	------------------
- 10 FOR TECHNICAL DATA REFER TO YOUR LOCAL TYCO ELECTRONICS SALES OFFICE
- 11 ALL DIMENSIONS ARE NOMINAL FOR REFERENCE ONLY UNLESS OTHERWISE STATED

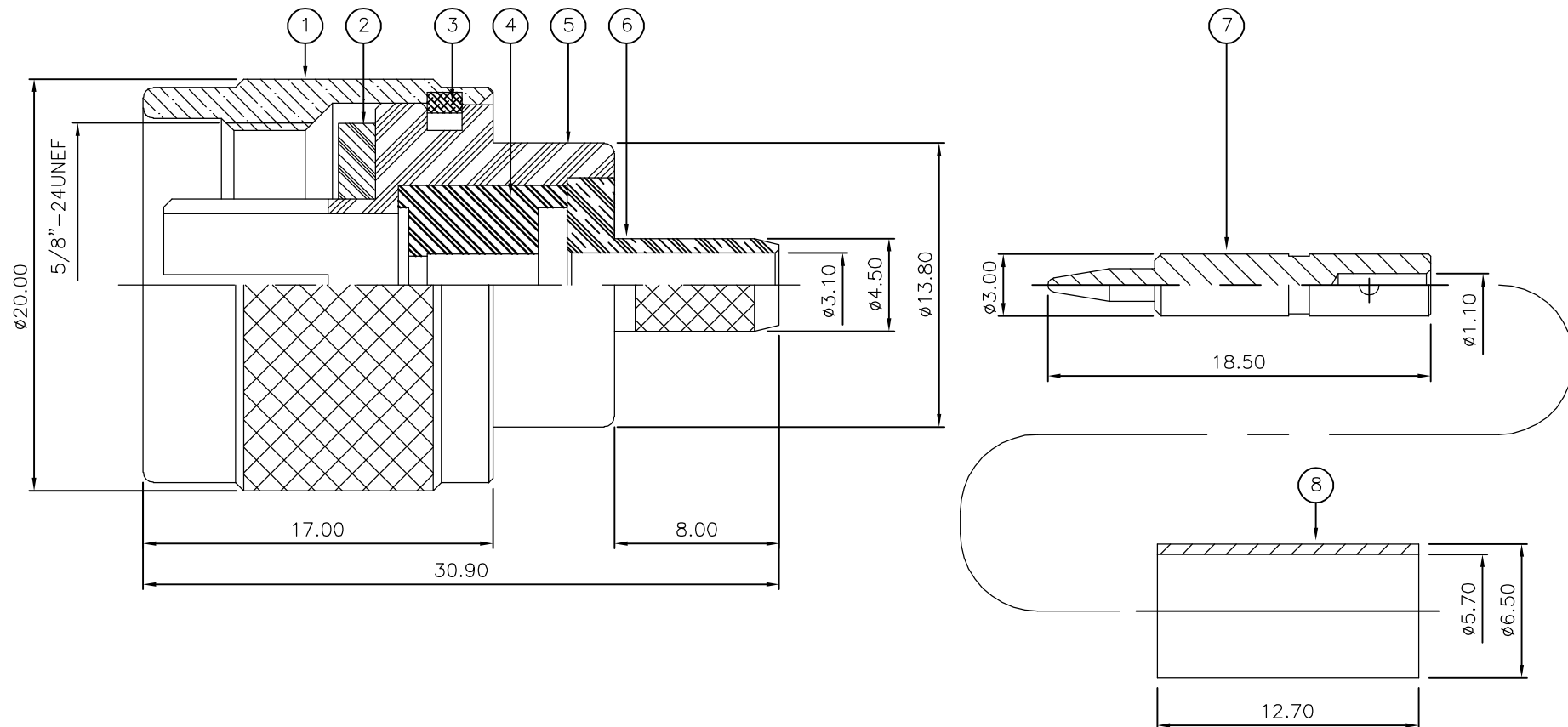

QTY	UNIT	MATERIAL	DESCRIPTION	ITEM
1	1	BRASS	FERRULE	8
1	1	BRASS	CONTACT	7
1	1	BRASS	CHASSIS	6
1	1	BRASS	BODY	5
1	1	PTFE	INSULATION	4
1	1	BRASS	CIRCLIP	3
1	1	SILICONE RUBBER	GASKET	2
1	1	BRASS	COUPLING NUT	1
6--0	1--0	MATERIAL	DESCRIPTION	ITEM

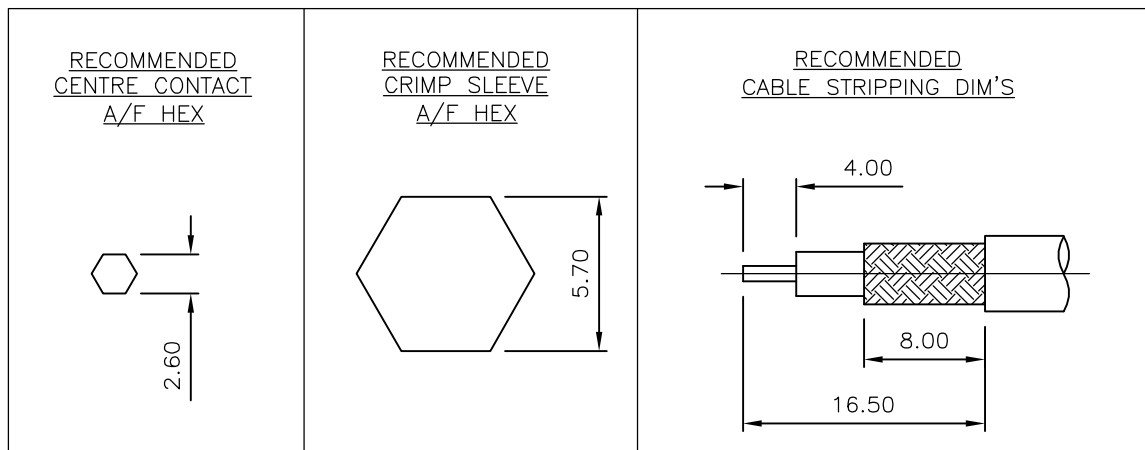

THIS DRAWING IS A CONTROLLED DOCUMENT.		DWN J.SANDWELL 01AUG06	Tyco Electronics Corporation Bideford EX39 4HE			
DIMENSIONS: mm		CHK S.PARLOW 01AUG06				
TOLERANCES UNLESS OTHERWISE SPECIFIED:		APVD F.WHEELER-KING 01AUG06	NAME			
0 PLC ± - 1 PLC ± - 2 PLC ± - 3 PLC ± - 4 PLC ± - ANGLES ± - FINISH -		PRODUCT SPEC -	TYPE 'N' STRAIGHT PLUG CRIMP 50 OHM RG55B/U, 142B/U, 223/U, 400/U, URM301, KX23			
MATERIAL SEE TABLE		APPLICATION SPEC 411-3247	SIZE A3	CAGE CODE 00779	DRAWING NO C-1478180	RESTRICTED TO -
CUSTOMER DRAWING			SCALE NTS	SHEET 1 OF 1	REV B	