

The CHAMELEON Adaptable Module for General, High Performance or Medical Applications

P Series



**UL Recognized
CSA Certified
VDE Approved**



PS Unfiltered

PS000SS30

PS Filtered

P Series

The P series power entry module offers fuller flexibility of design in a more compact package.

As the first 10 amp module to provide all five power entry functions in one compact design, the CHAMELEON module readily adapts to its environment and the needs of international markets.

- Snap-in or flange mounting
- IEC power line connector
- Both North American and European fusing capabilities
- Two voltage selections
- Optional DPST on/off switch
- Filtering options for general purpose, medical and high-performance applications.

The CHAMELEON modules compact design and modular construction will allow you to select the power entry features you require — without altering the panel cutout. And the Chameleon module, with adapters, will fit any standard panel cutout.

The CHAMELEON module has four filter options.

S models offer protection for general purpose applications where line-to-ground and line-to-line noise must be controlled. The filters are designed to meet low leakage requirements of VDE portable equipment. They are available in current ratings of 3, 6 and 10 amps.



PE Filter with "A" Shield

H models provide susceptibility protection without leakage current associated with line-to-ground capacitors and are designed to allow equipment to meet UL 544 for patient care and non-patient care equipment.

Also available is an interconnection block, **B models**. The block connects the voltage selection terminals of an unfiltered CHAMELEON module with a switch and an IEC connector to reduce external wiring.

L Models – High performance medical filter versions that are designed to help bring most digital equipment (including switching power supplies) into compliance with EN55022, Level B (as well as FCC part 15J, Class B) conducted emissions limits while additionally allowing equipment to meet UL544, UL2601 and EN60601 for patient care equipment and non-patient care equipment. They are available with current ratings of 6 and 10 amps. High performance versions are available with horizontal mounting ears, single voltage, complete can shield with options for switch, fuses and current ratings only. Extenders are not available.

Z Models – High performance filter versions are designed to help bring most digital equipment (including switching power supplies) into compliance with EN55022, Level B (as well as FCC Part 15J, Class B) conducted emissions limits. They are available with current ratings of 6 and 10 amps. High performance versions are available with horizontal mounting ears, no extenders, single voltage, complete can shield with options for switch, fuses and current ratings only.



The CHAMELEON Adaptable Module for General, High Performance or Medical Applications (Continued)

P Series

P Series Part Number Schematic

Part numbers are constructed by selecting the alphanumeric character which represents the desired feature.

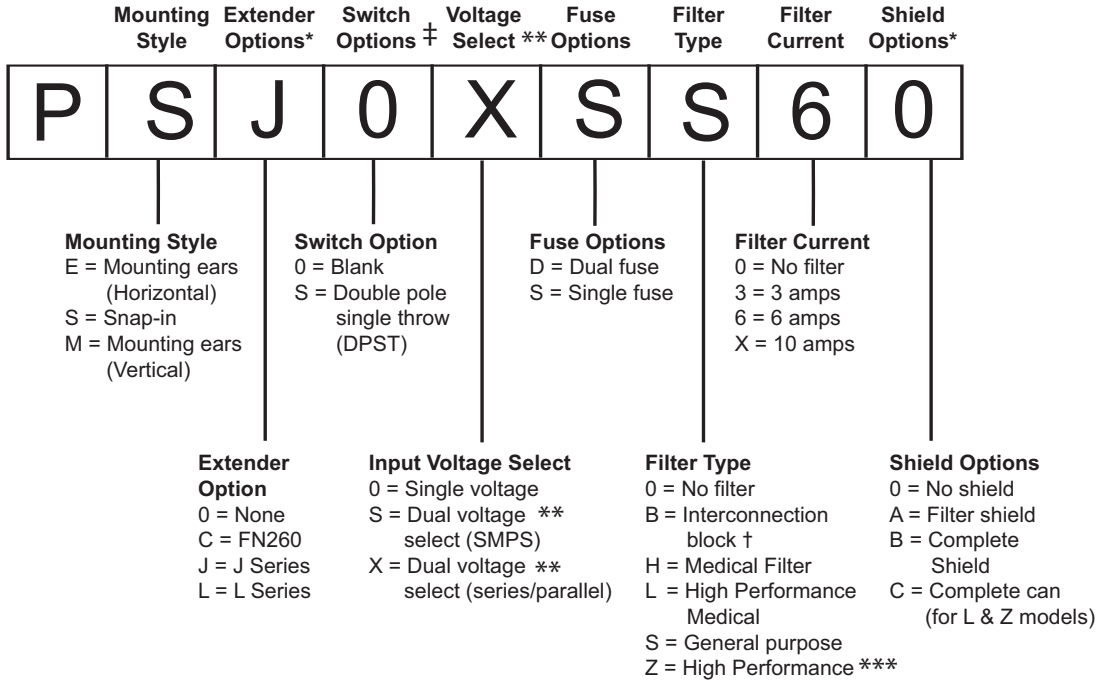

Notes:

- An additional extender which allows the P series to adapt to Corcom's L series product cutout as well as the panel cutout of Schaffner and Delta parts is also available.
- Extenders cannot be added to units with B shields
- † When using the interconnection block, the last 3 digits of the part number are BX (0, A, or B)
- ‡ For alternative switch orientation options, please contact technical support or your Corcom sales representative
- ** Dual voltage options only available with filter types O, H or S
- *** High performance versions are available with horizontal mounting ears (PE style), no extenders, single voltage, complete can shield with options for switch, fuses, filter type (L or Z) and 6 or 10 amp current ratings only.

The part number **PSJ0XSS60** would represent the equivalent of the Corcom J Series 6J4.

- P Series (**P**)
- with a snap-in mount (**S**)
- with the J extender to fit the 6J4 cutout(J), and includes no switch (**0**)
- dual voltage select (**X**)
- single fusing (**S**)
- general purpose filter (**S**)
- for 6 amps (**6**)
- with no shield (**0**).

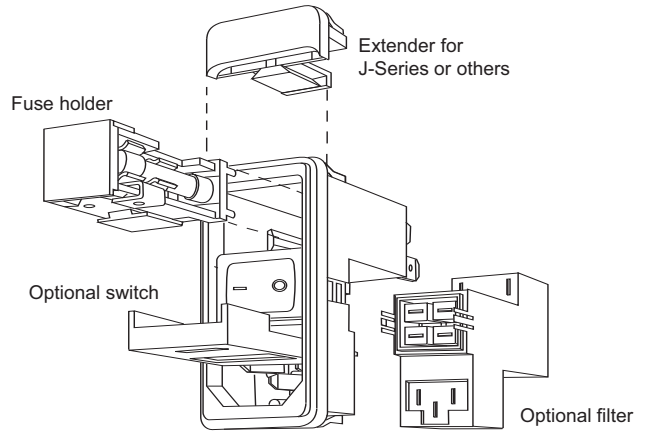

Additional extender which allows the P series to adapt to CORCOM's L series product cutout, as well as the panel cutout of Schaffner and Delta parts is available.

* Extenders cannot be added to units with B shields.

The CHAMELEON Adaptable Module for General, High Performance or Medical Applications (Continued)

P Series

Voltage Selection

The P series of power entry modules provides a dual voltage selector which is integrated with the fuseholder. To simplify the wiring in each individual application, Tyco Electronics provides dedicated voltage selectors for different voltage selection schemes. The two most popular schemes are the parallel and serial for dual primary transformers and the "DPST switch" for switching mode power supplies (jumper types.) P series products with an "S" as the fifth digit are specifically designed for "jumper" type applications associated with switching mode power supplies. P series products with an "X" as the fifth digit are specifically designed for dual primary transformer applications. The voltage selector installed will allow proper wiring from these applications. No matter what voltage selection scheme is used, wiring is always made to the same four terminals.

Input Voltage Selection Schemes

X - Dual Primary Transformer Type

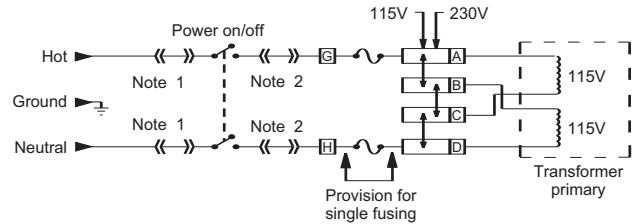

S - Jumper Type

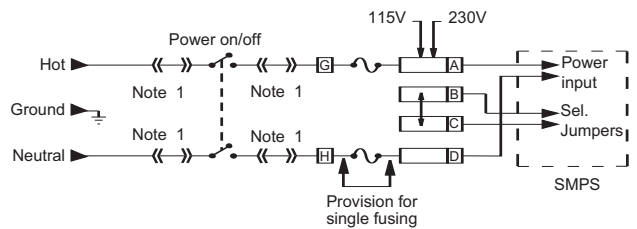

Note 1: Jumpers are required if a filter or interconnection module is not used.

Note 2: Location of optional filter. Jumpers are required if a filter or interconnection block is not used.

Shield

A new feature available on the P series is an RF shield. The metal shield, available on filtered models, provides shielding from radiated emissions and provides an additional RF ground for the filter to the case. The shield is available in two versions, a shield of the filter components (designated by A as the ninth digit) and a complete shield (designated by B as the ninth digit). The A shield covers the filter portion of the module and increases performance of the filter by protecting the components from magnetic coupling. This shield improves RF ground connection to the case while still allowing the use of the P Series extender. The B shield covers the entire power entry module with metal, protecting the equipment from all radiated noise. Used with the filter, the shield provides the most secure protection from RFI noise problems. The B shield cannot be used with any extender.



A Shield



B Shield

The CHAMELEON Adaptable Module for General, High Performance or Medical Applications (Continued)

P Series

Fuseholder

Another feature of the P series power entry module is a versatile fusing arrangement. Its fuseholder can hold two 1/4" x 1-1/4" or 5 x 20mm fuses. It can also be converted to accept one fuse with a conversion clip that bridges one of the two fuse chambers. The conversion clip is installed on the P Series power entry modules set for single fusing (those with part numbers with an "S" as the sixth digit). Units with a "D" as the sixth digit do not include a conversion clip.

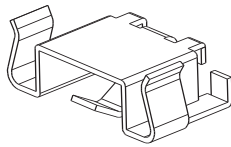

Conversion clip included for use in single fuse applications.

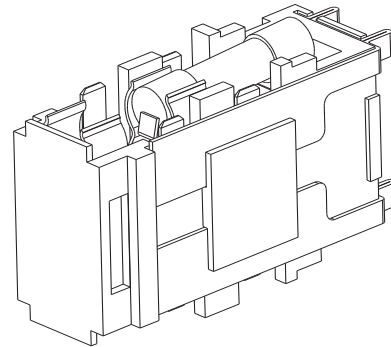

Fuseholder shown with 5x20mm fuse

Interconnection Block

Also available is an interconnection block (B models). The block connects the voltage selection terminals of an unfiltered CHAMELEON module with a switch and an IEC connector to reduce external wiring. Installation of the unfiltered versions of the P series involves wiring of the IEC socket to the switch and the switch to the fuseholder. Labor can be eliminated by ordering the product with an interconnection block. This feature, designated by a BX in the seventh and eighth digits, pre wires the module for easier installation. The wiring is protected with the plastic case to better prevent access to the terminals and connections.

The dimensions of this alternative are the same as the filtered versions.

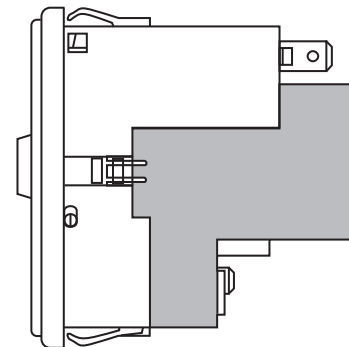

Interconnection Block installed in place of filter.

Accessories

A full range of accessories are available for the P Series. To simplify customer installation wiring can be simplified by ordering a PA100 connector assembly which is pre-wired with 6" of wire lead.

See page 143 for a complete list of all accessories available for this series.

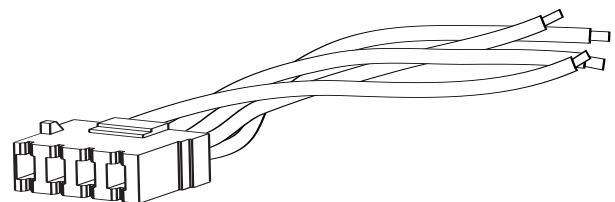

PA100 Assembly

The CHAMELEON Adaptable Module for General, High Performance or Medical Applications (Continued)

P Series

Electrical Schematics

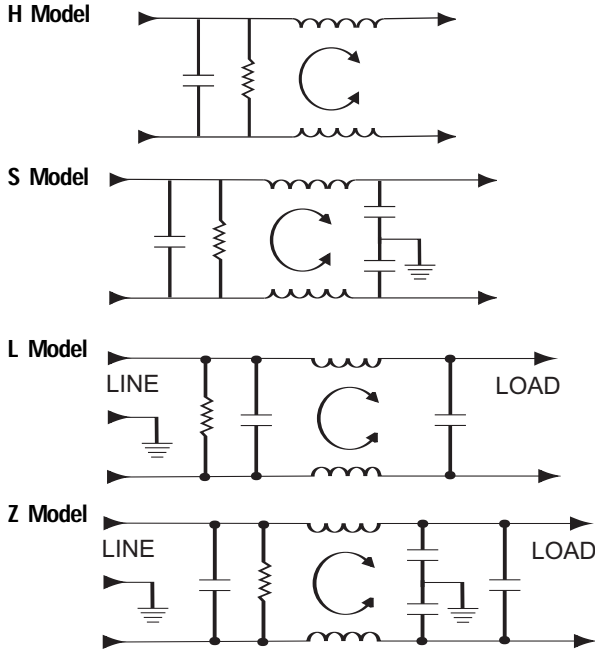

Specifications

Maximum leakage current, each line-to-ground: †

	H & L Models	S & Z Models
@ 120 VAC 60 Hz:	2 μ A	.25 mA
@ 250 VAC 50 Hz:	5 μ A	.50 mA

†Applies to Filtered models only

Hipot rating (one minute):

line-to-ground	1500 VAC
line-to-line	1450 VAC

Operating frequency: 50/60 Hz

Rated voltage: 250 VAC

Operating voltages: Selectable or Fixed 115/230 VAC

Rated current: Unfiltered – 10A
Filtered – 3, 6 or 10A

Switch: Double-insulated, rated for 10,000 operations at full load at 51 Amp inrush current

Fuseholder: Accepts one or two fuses
1/4 x 1-1/4 or 5 x 20 mm
Conversion clip provided on fuseholder for single fuse models.

Terminals:

Standard versions: .187 x 0.032 [4.8 x .87] terminal tabs

High performance versions: .250 x 0.032 [6.4 x .87] terminal tabs

Recommended for use with mating connector - no solder

Minimum insertion loss in dB:

Line-to-ground in 50 ohm circuit

Current Rating	Frequency-MHz								
	.03	.1	.15	.5	1	3	5	10	30
H Models									
3A	7	17	21	27	30	29	26	23	15
6A	-	8	11	15	17	19	18	16	13
10A	3	5	8	10	12	11	11	10	10
S Models									
3A	7	17	21	27	33	40	44	50	32
6A	-	8	12	17	23	32	36	44	30
10A	-	3	5	10	13	23	27	35	27

Current Rating	Frequency-MHz								
	.01	.05	.1	.15	.5	1	5	10	30
Z Models									
6A	8	21	27	30	37	43	49	52	42
10A	5	17	22	24	27	32	52	47	40
L Models									
6A	8	21	27	29	34	35	25	21	16
10A	5	17	22	23	24	25	21	18	14

Line-to-line in 50 ohm circuit

Current Rating	Frequency-MHz								
	.10	.15	.5	1	3	5	10	30	
H Models									
3A	2	4	12	18	31	40	48	41	
6A	2	4	12	16	26	35	40	35	
10A	2	4	12	16	26	33	40	32	
S Models									
3A	2	4	12	15	30	48	50	45	
6A	2	4	12	15	22	42	55	45	
10A	2	4	12	15	22	42	55	45	

Current Rating	Frequency-MHz								
	.01	.05	.1	.15	.5	1	5	10	30
Z Models									
6A	10	15	34	44	75	75	75	70	60
10A	10	20	20	35	67	75	75	70	60
L Models									
6A	10	15	34	44	75	75	75	70	60
10A	10	20	20	35	67	75	75	70	60

The CHAMELEON Adaptable Module for General, High Performance or Medical Applications (Continued)

P Series

Case Styles

PS/PSL

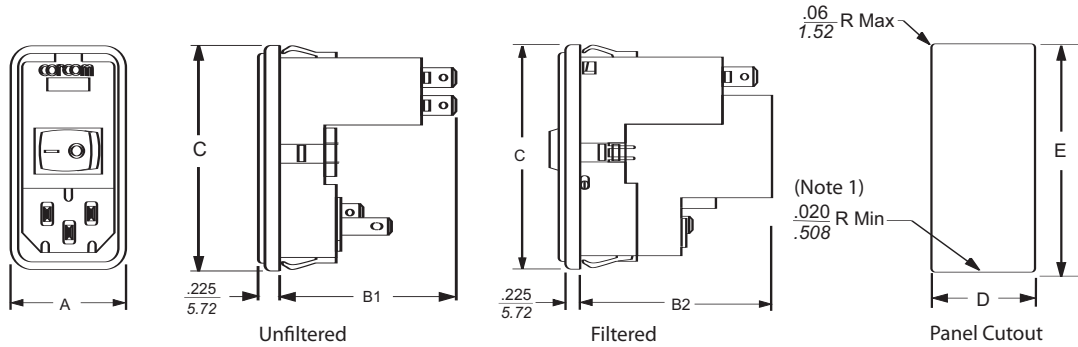

Note1: For snap-in applications, the D sides of the cutout must have a $.02$ [$.508$] radius on the installation side. Snap-in models allow front mounting only. Not recommended for plastic panels.

PE

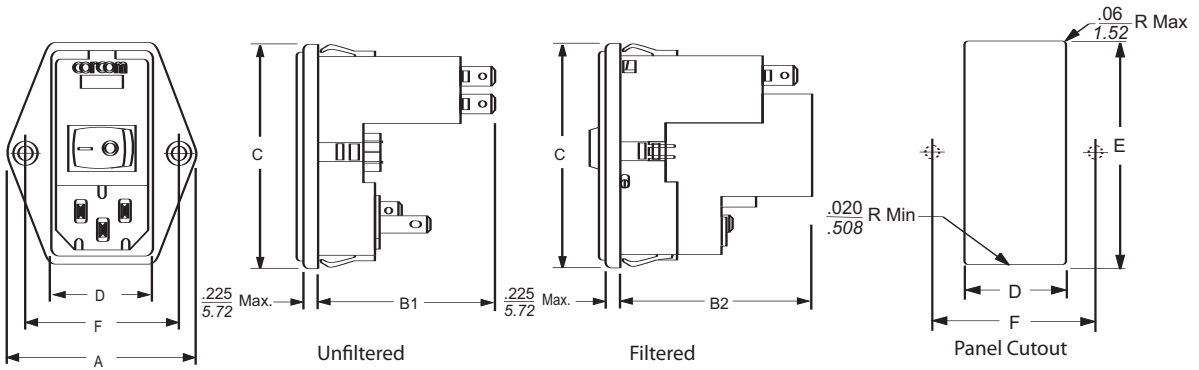

PM

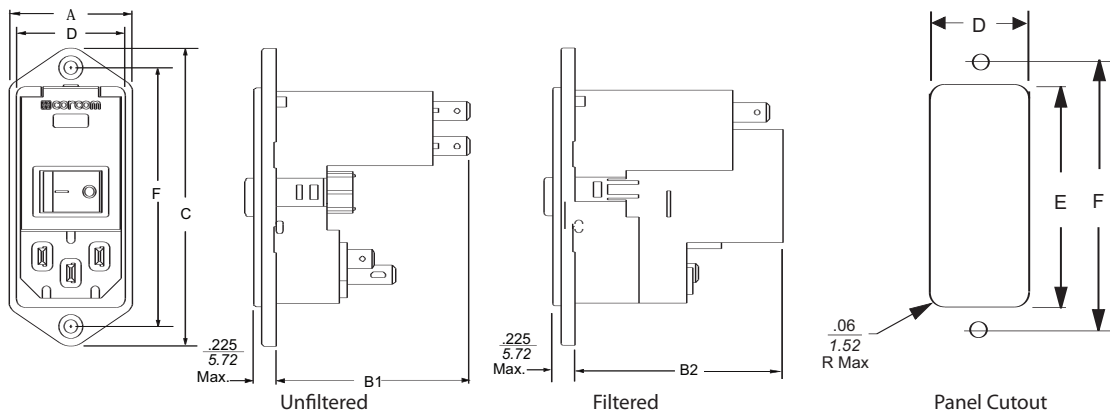

Typical dimensions:

Terminals: $.187 \times 0.032$ [$4.8 \times .81$] terminal tabs

Slot (Ground Terminal): $.06 \times .115$ [1.52×2.92] $\pm .004$ [1.0]

Holes: $.055$ [1.5] Dia. $\pm .004$ [1.0]

Mounting Holes (PE, PM only): $.135$ [3.43] Dia. (2) countersunk

The CHAMELEON Adaptable Module for General, High Performance or Medical Applications (Continued)

P Series

Case Styles (continued)

PSC/PSJ

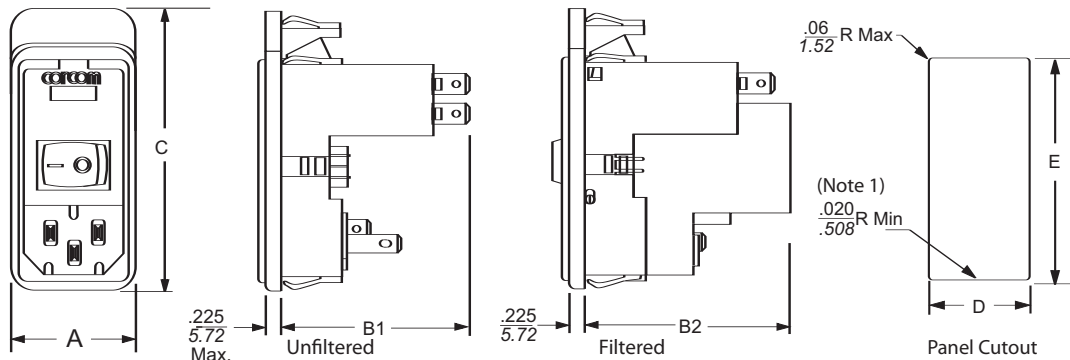

Note 1: For snap-in applications, the D sides of the cutout must have a .02 [.508] radius on the installation side. Snap-in models, allow front mounting only.

Typical dimensions:

Terminals: .187 x 0.032 [4.8 x .81] terminal tabs

Slot (Ground Terminal): .06 x .115 [1.52 x 2.92] ±.004 [1.0]

Holes: .055 [1.5] Dia. ±.004 [1.0]

Mounting Holes (PE, PM only): .135 [3.43] Dia. (2) countersunk

PE High Performance

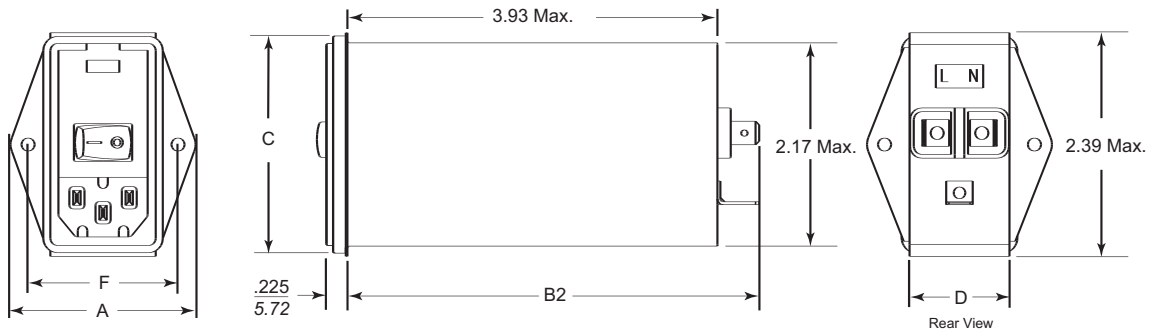

Note 1: Use cutout for PE Style.

Typical dimensions:

Terminals: .250 x 0.032 [6.4 x .81] terminal tabs

Slot (Ground Terminal): .07 x .16 [1.8 x 4.1]

Holes: .07 [1.8] Dia. (2)

Mounting Holes: .135 [3.43] Dia. (2) countersunk

The CHAMELEON Adaptable Module for General, High Performance or Medical Applications (Continued)

P Series

Shielding

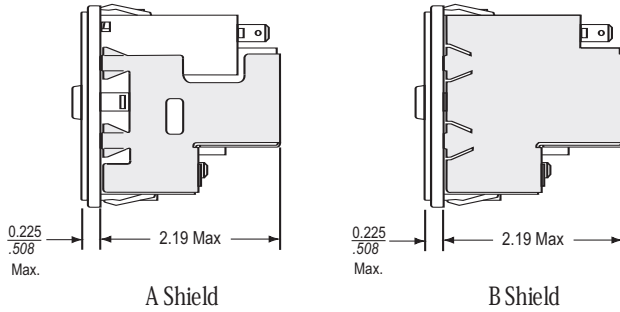

Shields can be used only with filtered models.
Shields add approximately 0.06" to depth.
B shield may not be used with J or C extender.

Rear View

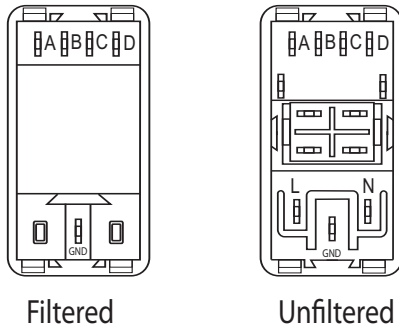

Case Dimensions

Part No.	A (max)	B1 (max)	B2 (max)	C (max)	D $\frac{+.008/-0.00}{+.20/-0.0}$	E $\frac{+.008/-0.00}{+.20/-0.0}$	F
PS	1.24 31.49	1.93 49.02	2.13 54.1	2.31 58.67	1.06Δ 26.93	2.201* 55.91	—
PSL	1.24 31.49	1.93 49.02	2.13 54.1	2.31 58.67	1.12 28.45	2.201* 55.91	—
PE	1.98 50.29	1.93 49.02	2.13 54.1	2.31 58.67	1.122 28.5	2.201* 55.91	1.575 40.0
PM	1.24 31.49	1.93 49.02	2.13 54.1	2.9 73.66	1.06 26.93	2.13 54.1	2.496 63.4
PSC	1.24 31.49	1.93 49.02	2.13 54.1	2.51 63.75	1.06 26.93	2.52 64.01	—
PSJ	1.24 31.49	1.93 49.02	2.13 54.1	2.72 69.09	1.06 26.93	2.6⁺ 66.0	—
PE High Performance	1.98 50.29	—	4.42 112.27	2.31 58.67	1.12 28.5	2.201 55.91	1.575 40.0

* Panel cutout for thickness of .031 - .079 [08-20]. For panel thickness at .083 - .114 [21-29] use 2.213 [56.2].
+ Panel cutout for thickness of 0.06 - 0.09 [0.76 - 2.29].
Δ For shielded models use D=1.12+.008/-0.00.

Power Entry Modules