

THIS DRAWING IS UNPUBLISHED. RELEASED FOR PUBLICATION  
 © COPYRIGHT BY TYCO ELECTRONICS CORPORATION. ALL RIGHTS RESERVED.

LOC		DIST		REVISIONS			
P	LTR	DESCRIPTION		DATE	DWN	APVD	
FT	0	W1	REVISED PER ECO-08-017797	22JUL08	HMR	GS	

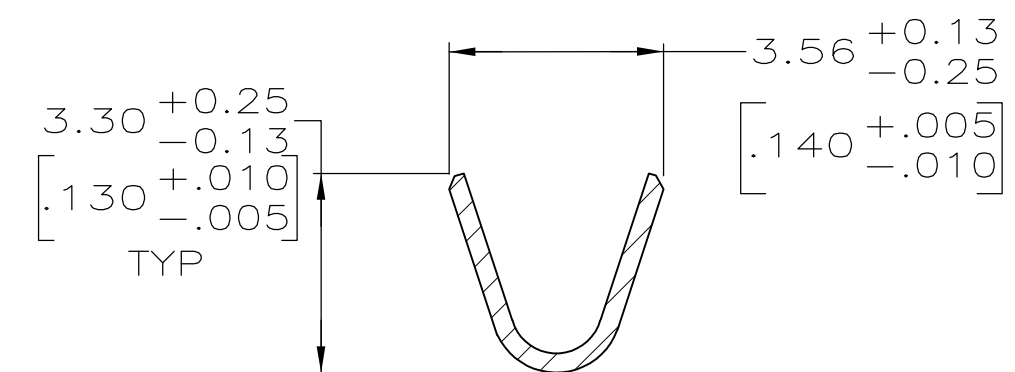

Ø1.689 ± 0.051  
 [.0665 ± .0020]

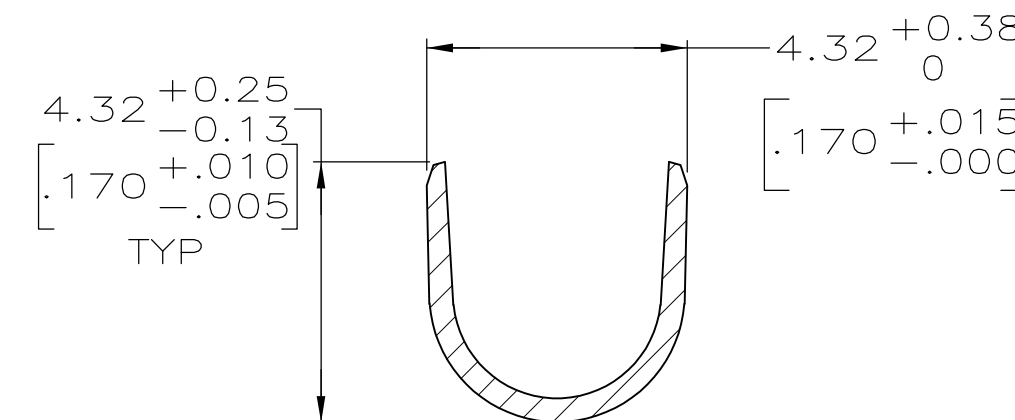
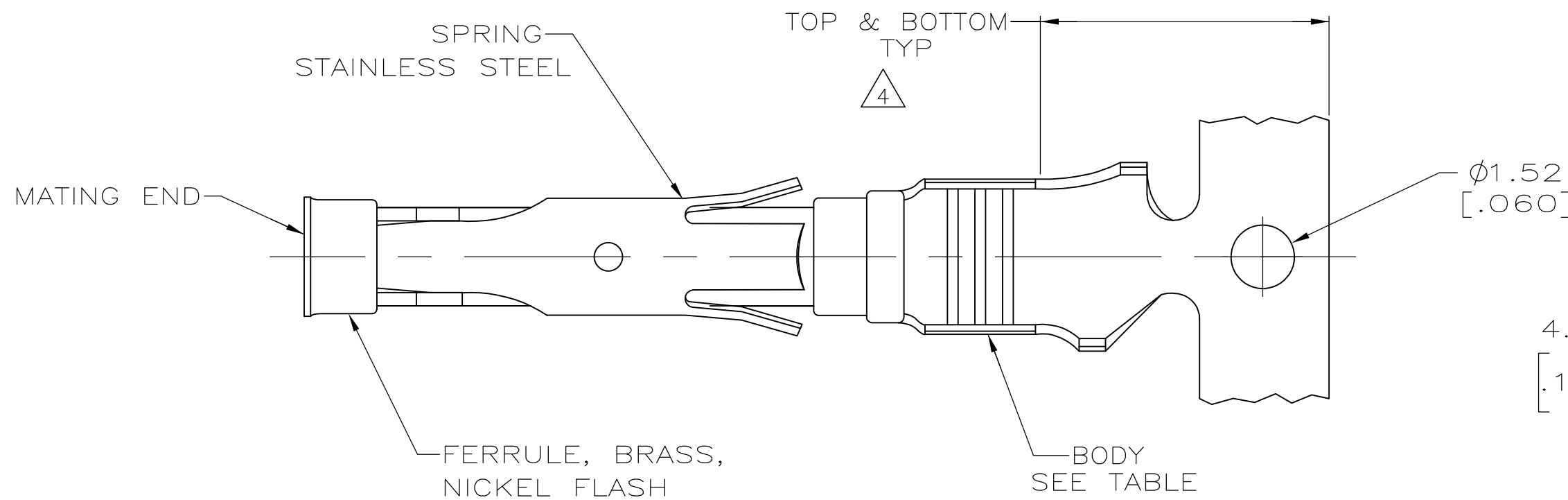
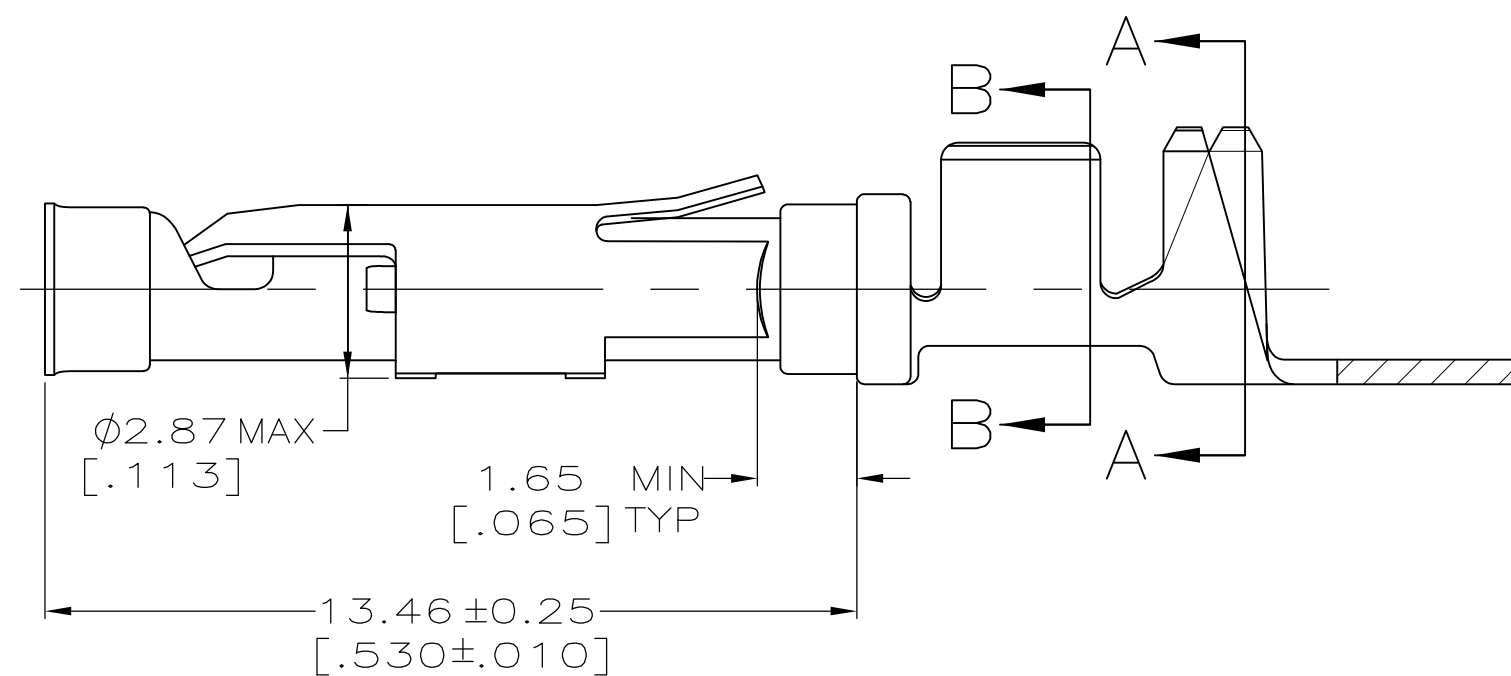
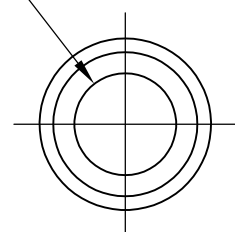

- 1 0.51µm [.000020] MIN GOLD PER MIL-G-45204 ON MATING END FOR A LENGTH OF 5.08 [.200] MIN WITH GOLD FLASH ON THE REMAINDER OVER 0.76µm [.000030] MIN NICKEL PER QQ-N-290.
- 2 1.27µm [.000050] MIN TIN-LEAD PER MIL-T-10727 OVER 0.76µm [.000030] MIN NICKEL PER QQ-N-290.
- 3 0.76µm [.000030] MIN GOLD PER MIL-G-45204 ON MATING END FOR A LENGTH OF 5.08 [.200] MIN WITH GOLD FLASH ON THE REMAINDER OVER 0.76µm [.000030] MIN NICKEL PER QQ-N-290.
- 4 GOLD PLATING NEED NOT APPEAR IN THIS AREA.
- 5 REVERSE REELED FOR MINI-APPLICATOR.
- 6 WIRE RANGE 14-18 AWG. INSULATION RANGE 2.79[.110]-3.81[.150].
- 7 0.38µm [.000015] MIN GOLD PER MIL-G-45204 ON MATING END FOR A LENGTH OF 5.08 [.200] MIN, 1.27µm [.000050] MIN TIN-LEAD PER MIL-T-10727 FOR A LENGTH OF 5.69 [.224] MIN ON OPPOSITE END, BOTH OVER 1.27µm [.000050] MIN NICKEL PER QQ-N-290 ON ENTIRE CONTACT.
- 8 1.27µm [.000050] MIN TIN PER MIL-T-10727 OVER 0.76µm [.000030] MIN NICKEL PER QQ-N-290.
- 9 0.38µm [.000015] MIN. GOLD PER MIL-G-45204 ON MATING END FOR A LENGTH OF 5.08 [.200] MIN. WITH GOLD FLASH ON THE REMINDER, OVER 1.27µm [.000050] MIN. NICKEL PER QQ-N-290.
- 10 PRELIMINARY - NOT FOR PRODUCTION.

FINISH	BODY MATERIAL	LOOSE PIECE REF	PART NUMBER
9	CU-NI ALLOY	-	1-66598-5
8	BRASS	-	1-66598-4
8	PHOSPHOR BRONZE	-	1-66598-3
8	CU-NI ALLOY	1-66601-2	1-66598-2
3	CU-NI ALLOY	1-66601-0	1-66598-1
8	BRASS	-	1-66598-0
8	BRASS	66601-9	66598-9
7	BRASS	66601-5	66598-8
2	BRASS	-	66598-7
3	PHOSPHOR BRONZE	66601-4	66598-6
2	PHOSPHOR BRONZE	66601-3	66598-5
1	BRASS	-	66598-3
3	BRASS	66601-2	66598-2
2	BRASS	66601-1	66598-1

THIS DRAWING IS A CONTROLLED DOCUMENT.

DWN	M.HOFFECKER	8-11-88
CHK	J.McCLINTON	8-11-88
APVD	-	-

**Tyco Electronics** Tyco Electronics Corporation  
 Harrisburg, PA 17105

NAME: SOCKET ASSEMBLY, .062, TYPE III+

SIZE	CAGE CODE	DRAWING NO	RESTRICTED TO
A2	00779	C-66598	-

CUSTOMER DRAWING SCALE 8:1 SHEET 1 OF 1 REV W1