

SAFETY ORGANIZATIONS

THIS FILTER HAS BEEN FORMALLY RECOGNIZED, CERTIFIED OR APPROVED BY THE LISTED AGENCY. THEREFORE, ALL TEST/REQUIREMENTS SPECIFIED IN THE LATEST REVISION OF THE FOLLOWING AGENCY STANDARDS HAVE BEEN MET:

- UL RECOGNIZED: UL 1283
- CSA CERTIFIED: CSA C22.2 No. 8
- VDE APPROVED: EN 60939-2

OPERATING SPECIFICATIONS

LINE CURRENT/VOLTAGE: 6 AMP, 120/250 VAC,
6 AMP/40°C, 250 VAC

LINE FREQUENCY: 50-60Hz

MAXIMUM LEAKAGE CURRENT,
EACH LINE TO GROUND: 2µ A @ 120V 60Hz
5µ A @ 250V 50Hz

OPERATING AMBIENT TEMP. RANGE: -10°C TO +40°C @ RATED CURRENT, I_r.

IN AN AMBIENT, T_a, HIGHER THAN 40°C, THE MAXIMUM OPERATING CURRENT, I_o, IS AS FOLLOWS:

$$I_o = I_r \sqrt{\frac{85 - T_a}{45}}$$

RELIABILITY SPECIFICATIONS:

STORAGE TEMPERATURE: -40°C TO +85°C
HUMIDITY: 21 DAYS @ 40°C 95% RH.
CURRENT OVERLOAD TEST: 6 TIMES I_r FOR 8 SECONDS

TEST SPECIFICATIONS:

INDUCTANCE: 6.2 mH NOMINAL
CAPACITANCE: (MEASURED @ 1KHz, 0.250VAC MAX., 25°C±1°C)
LINE TO GROUND: N/A µF±20%
LINE TO LINE: 2.0 µF±20%
DISCHARGE RESISTOR: 165 KΩ
L/C AND L/L I.R.
NO DISCHARGE RESISTOR: 6000MΩ (MIN.) @ 100VDC, 20°C AND 50% RH

RECOMMENDED RECEIVING INSPECTION HIPOT:

LINE TO GROUND: 1500 VAC FOR 1 MINUTE
LINE TO LINE: 1450 VDC FOR 1 MINUTE

FILTER APPROVAL:

THE BEST WAY TO SELECT AND QUALIFY A FILTER IS FOR YOUR ENGINEERING TO TEST THE UNIT IN YOUR EQUIPMENT.

CUSTOMER DRAWING

CATALOG # PE000DL6C

ECN#	APPRVD	DATE
09-013614	Z	04SEP09

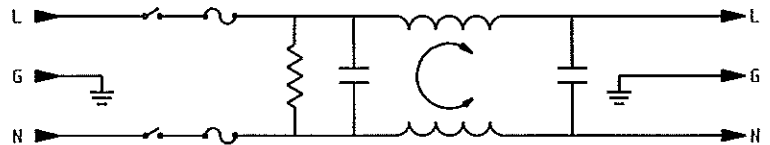
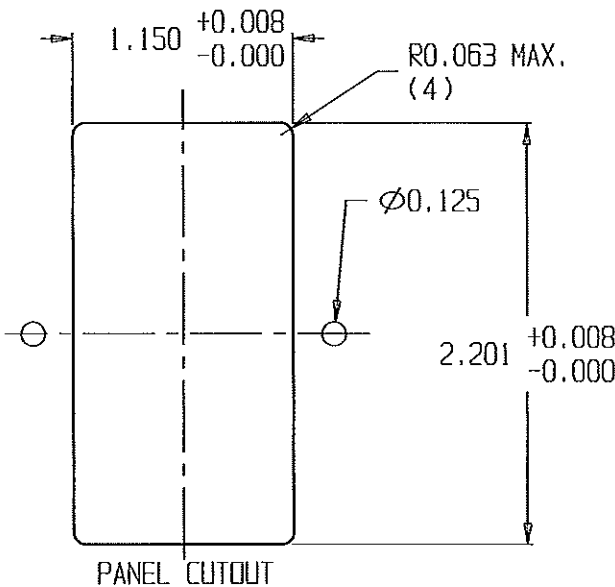
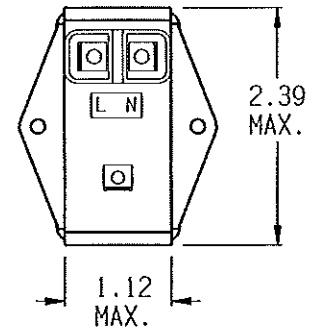
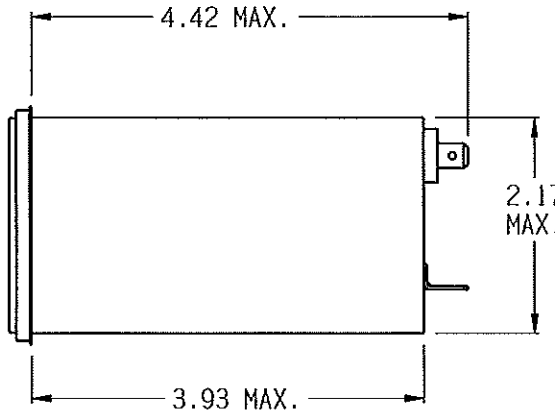
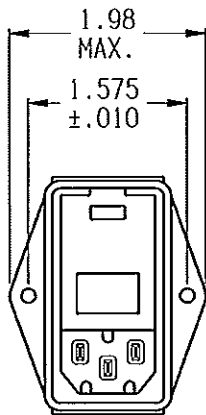

50Ω - 50Ω (MINIMUM) INSERTION LOSS

FREQUENCY MHz	.01	.05	.10	.15	.50	1.0	5.0	10.0	30.0	/	/	/
COMMON dB	5	17	22	23	24	25	21	18	14	/	/	/
DIFF. dB	10	20	20	35	67	75	75	70	60	/	/	/

PARTS SHALL COMPLY WITH TYCO ELECTRONICS 138-702 SPECIFICATION FOR HAZARDOUS SUBSTANCES

UNLESS OTHERWISE SPECIFIED
TOLERANCE TO BE ±0.025
MATERIAL & FINISH: AS SUPPLIED

NOTES:

Tyco Electronics
CORPORATION PRODUCTS, 620 S. BUTTERFIELD RD., HANDELSIN IL 60060

POWER LINE FILTER

TYCO ELECTRONICS PART NO. 6609109-1

SCALE: NTS	DATE: 28APR00	DRIVING NUMBER: PE000DL6C	REV: A
DRW. BY: L.J.D	DRG6: MAC		



THIS INFORMATION IS CONFIDENTIAL AND PROPRIETARY TO TYCO ELECTRONICS CORPORATION AND ITS WORLDWIDE SUBSIDIARIES AND AFFILIATES. IT MAY NOT BE DISCLOSED TO ANYONE OTHER THAN TYCO ELECTRONICS PERSONNEL, WITHOUT WRITTEN AUTHORIZATION FROM TYCO ELECTRONICS CORPORATION, HARRISBURG, PENNSYLVANIA USA.