

LOC	DIST	REVISIONS					
		P	LTR	DESCRIPTION	DATE	DWN	APVD
HJ	-		A4	Doc change E2000-DOK02 to C-1462037-2	08DEC2003	CW	HD
			A5	change marking	24JUL2006	UKo	HD
			A6	new bottom view	28Jul2006	UKo	HD
			A7	additional marking	10OCT2008	UKo	HD

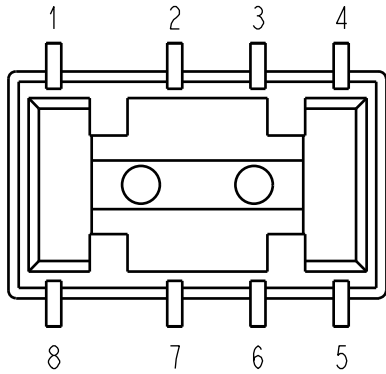

Relay - bottom view

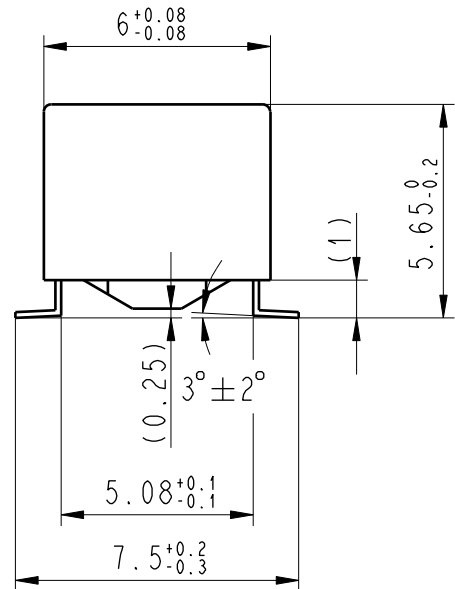
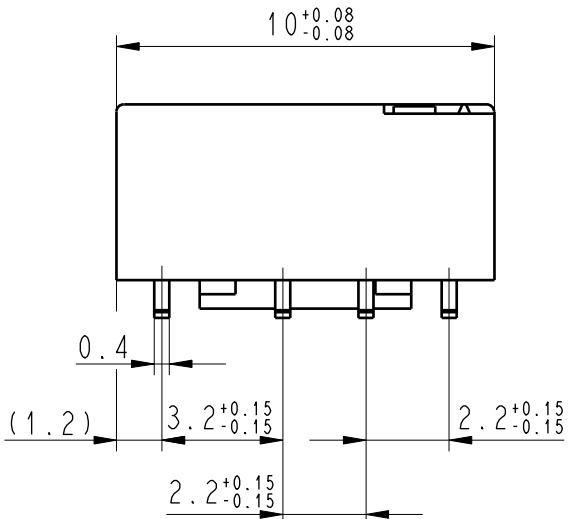

Coplanarity < 0.10mm

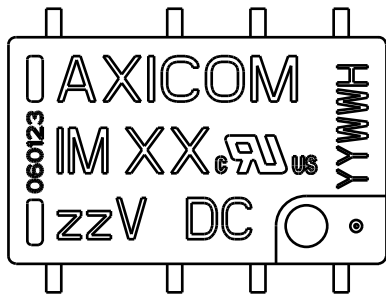

XX = Relay type
zz = nominal voltage
YYWW = Date code

DRAWING ALIAS
E2000-DOK02

2000
RELEASED FOR PUBLICATION

THIS DRAWING IS UNPUBLISHED.

© COPYRIGHT 2000 BY TYCO ELECTRONICS CORPORATION. ALL RIGHTS RESERVED.

DIMENSIONS: mm	DWN UKo 9193	20Jan1999	MATERIAL	-	FINISH	-
	CHK HD 9121	20Jan1999	Tyco Electronics Logistics AG Werk Axicom Au, CH-8804 Au ZH			
TOLERANCES UNLESS OTHERWISE SPECIFIED: DIN 7168-m	APVD HD 9121	20Jan1999				
0 PLC ±-	PRODUCT SPEC	-	NAME IM-Relay SMT Gull Wings Dimensions			
1 PLC ±-	APPLICATION SPEC	-	SIZE	CAGE CODE	DRAWING NO	RESTRICTED TO
2 PLC ±-			A 4	00779	C-1462037-2	-
3 PLC ±-			CUSTOMER DRAWING			
4 PLC ±-	WEIGHT	-	SCALE	5:1	SHEET 1 OF 1	REV A7
ANGLES ±-						

