

MATERIALS			
NO	COMPONENT NAME	BASE MATERIAL	FINISH
1	HOUSING	DIALYL PHTHALATE RESIN	
2	END TERMINAL	SILVER CLAD COPPER ALLOY	GOLD FLASH
3	CENTER TERMINAL	COPPER ALLOY	GOLD FLASH
4	ROCKER CONTACT	SILVER CLAD COPPER ALLOY	GOLD FLASH
5	ACTUATOR TIP	PHENOL RESIN, UL94 HB	
6	ACTUATOR SPRING	MUSIC WIRE	
7	ACTUATOR	PHENOL RESIN, UL94 HB	
8	ACTUATOR GUIDE	POLYAMID	
9	FRAME	STAINLESS STEEL PER 100-77	
10	RETAINER/STOPPER	BRASS	NONE
11	PLUNGER SPRING	MUSIC WIRE	
12	PLUNGER PIN	BRASS	
13	BUSHING	ZINC	NICKEL
14	PLUNGER	BRASS	NICKEL
15	MOUNTING NUTS (1)	BRASS	NICKEL
17	INTERNAL TOOTL LOCKWASHER	STEEL	NICKEL
18	STEM O-RING		
19	BUSHING O-RING		

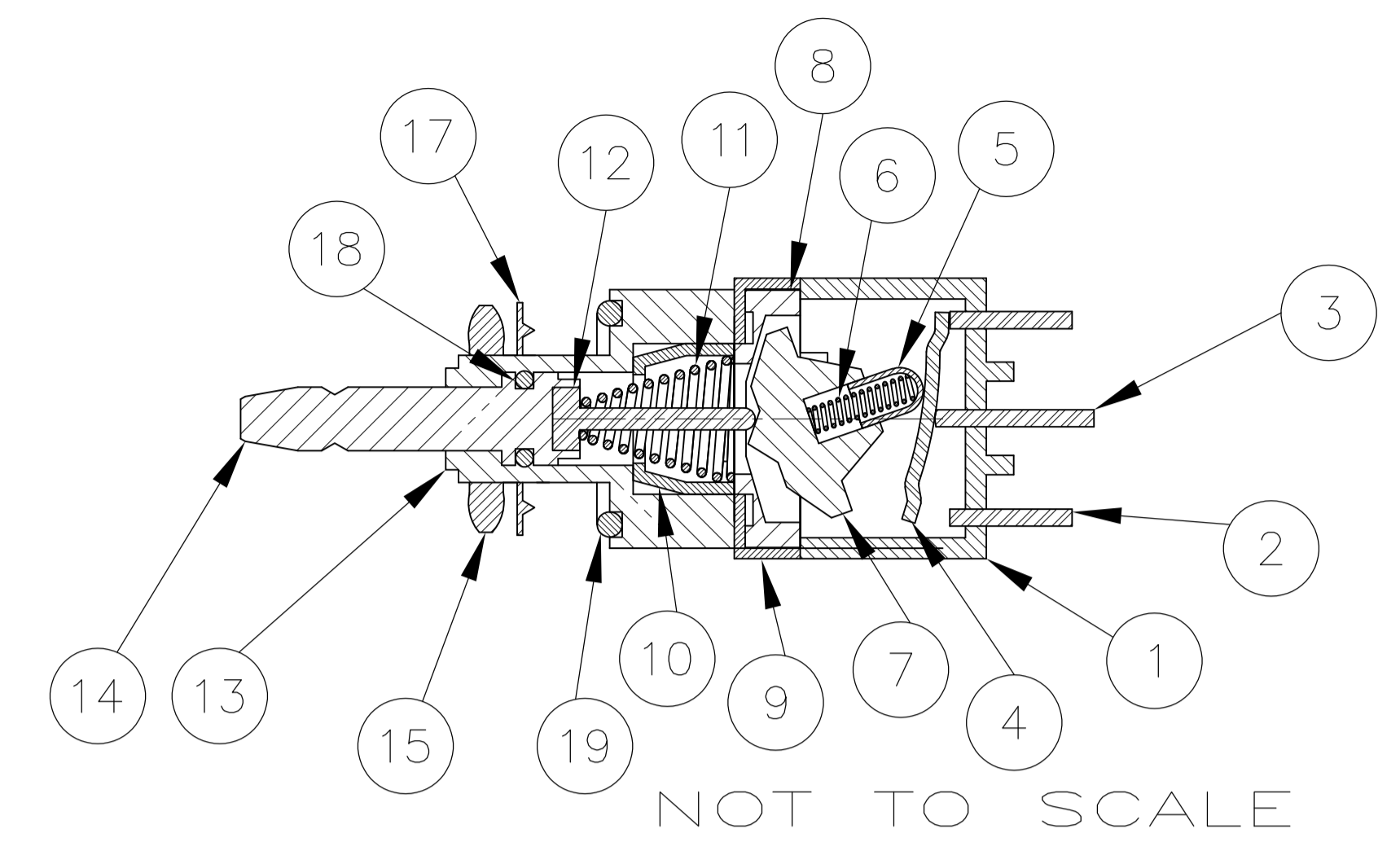

NOT TO SCALE

SPECIFICATIONS - SEE NOTE 3			
CURRENT RATING UL & CSA	6A @ 125 VAC (RESISTIVE)		
	3A @ 250 VAC (RESISTIVE)		
	4A @ 28 VDC (RESISTIVE)		
INITIAL CONTACT RESISTANCE	10 MILLIOHMS MAX @ 2-4 VDC, 1A		
DIELECTRIC STRENGTH	1,500 MEGOHMS MIN.		
WITHSTANDING VOLTAGE	1,000 VAC		
TRAVEL	.140		
ACTUATION FORCE	.4 to 2 kgf		
OPERATING TEMPERATURE	-20C TO +85C		
STORAGE TEMPERATURE	-40C TO +85C		
CONTACT TIMING	BREAK BEFORE BREAK		
TERMINAL SEAL	OVER MOLDED		
DURABILITY	PARAMETER	PUSH ON/ PUSH OFF	MOMENTARY
	250 VAC (3A RESISTIVE)	50,000	50,000
	125 VAC (6A RESISTIVE)	50,000	50,000
	28 VDC (4A RESISTIVE)	50,000	50,000

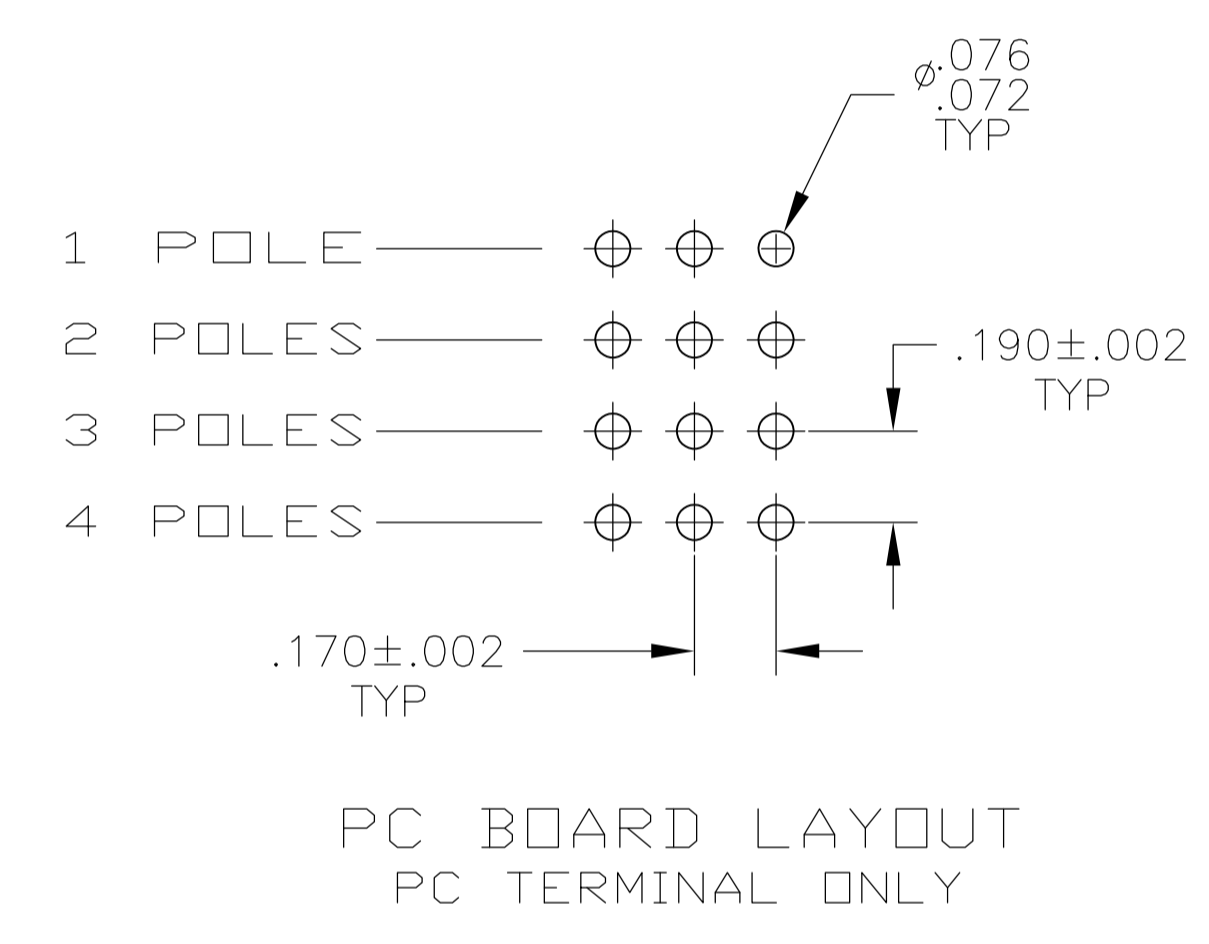
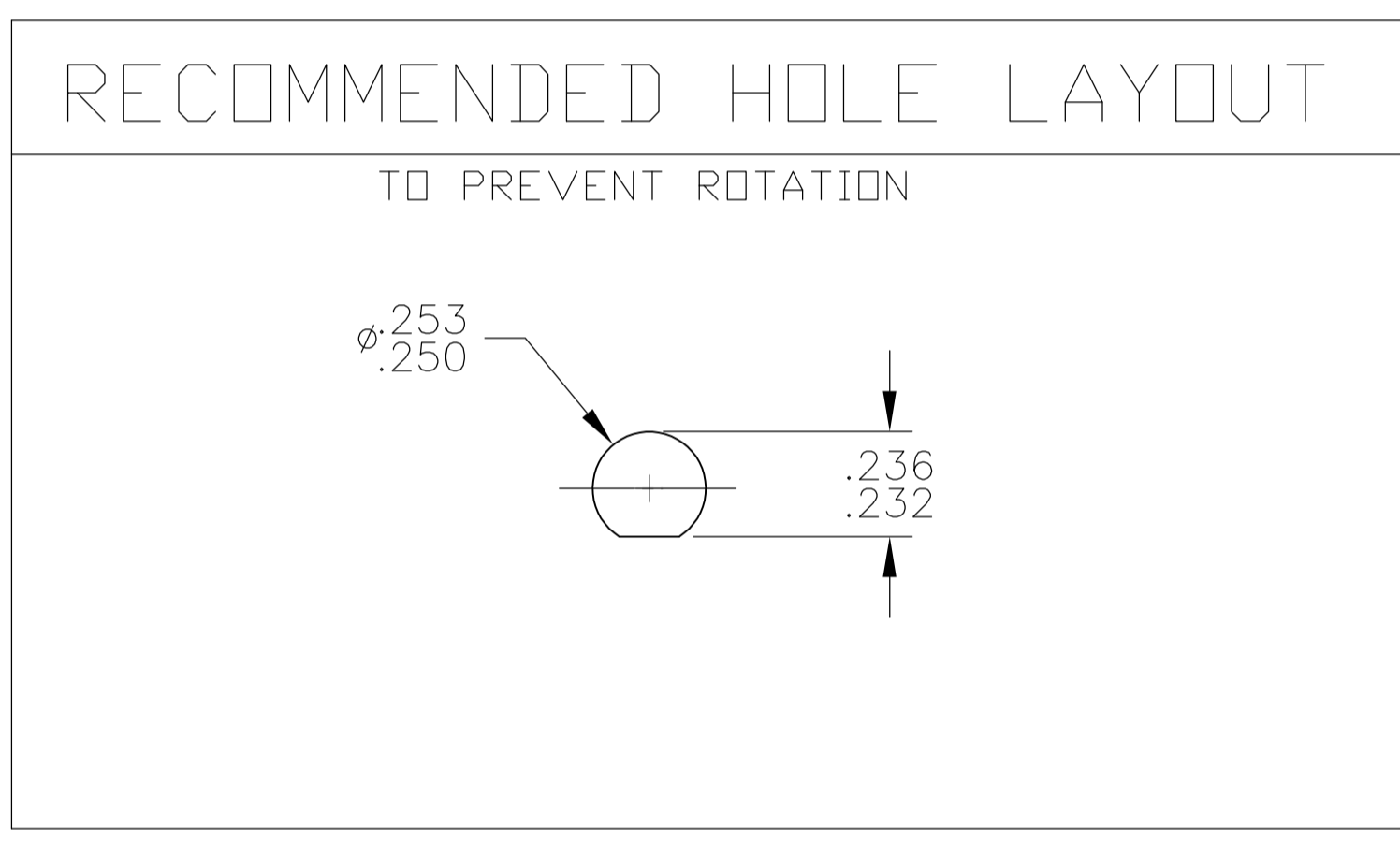

- NOTES:
- TERMINAL NUMBERS ARE FOR REFERENCE ONLY AND DO NOT APPEAR ON THE SWITCHES.
 - EACH SWITCH SUPPLIED WITH THE FOLLOWING MOUNTING HARDWARE:
 - (1) 1/4-40 UNS-2B HEX NUT
 - (1) LOCK WASHER
 - (1) BUSHING 'O' RING
 - SWITCHES TESTED TO AND MEET THE REQUIREMENTS OF UL 61058-1A,
 - 5 WIRE LUG CONTACTS WILL ACCEPT 2 #20 AWG SOLID OR STRANDED WIRES.
 - 6 MARK SWITCH
 - ALL MATERIALS AND FINISHES SHALL COMPLY WITH EU DIRECTIVE 2002/95/EC OF 27JAN2003 (ROHS).
 - SWITCHES INCLUDE BLACK PUSHBUTTON CAP (P/N 1825070-1).

PART NUMBER	Alco P/N	Mark Switch	Poles	Throws	Terminal	Function		Connected Terminals	
						ON	MOM	Terminal Config 1	Terminal Config 2
4-1437567-8	MPE406R	MPE 406R	4	2	Wire lug	ON	MOM	2-1, 5-4, 8-7, 11-10	2-3, 5-6, 8-9, 11-12
4-1437567-7	MPE406N	MPE 406N	4	2	Wire lug	ON	ON	2-1, 5-4, 8-7, 11-10	2-3, 5-6, 8-9, 11-12
4-1437567-6	MPE306F	MPE 306F	3	2	Wire lug	ON	MOM	2-1, 5-4, 8-7	2-3, 5-6, 8-9
4-1437567-5	MPE206R	MPE 206R	2	2	Wire lug	ON	MOM	2-1, 5-4	2-3, 5-6
4-1437567-4	MPE206N	MPE 206N	2	2	Wire lug	ON	ON	2-1, 5-4	2-3, 5-6
4-1437567-3	MPE106F	MPE 106F	1	2	Wire lug	ON	MOM	2-1	2-3
4-1437567-2	MPE106D	MPE 106D	1	2	Wire lug	ON	ON	2-1	2-3

THIS DRAWING IS A CONTROLLED DOCUMENT.

DIMENSIONS: INCHES	TOLERANCES UNLESS OTHERWISE SPECIFIED:	DIN M. BINNER 15NDV04	15NDV04	Tyco Electronics Corporation Harrisburg, PA
0. PLC ± -	1. PLC ± -	DM M. ZITTO 15NDV04	15NDV04	NAME: ALCO SWITCH GREEN SERIES PUSHBUTTON SWITCH, MPE SERIES
2. PLC ± -	3. PLC ± .012	APVD M. ZITTO 15NDV04	15NDV04	PRODUCT SPEC
4. PLC ± -	ANGLES ± -	APPLICATION SPEC		SIZE: A1
MATERIAL	FINISH	WEIGHT		CAGE CODE: 00779
				DRAWING NO: 4-1437567-3
				RESTRICTED TO: -
				SCALE: 3:1
				SHEET 1 OF 3
				REV A1

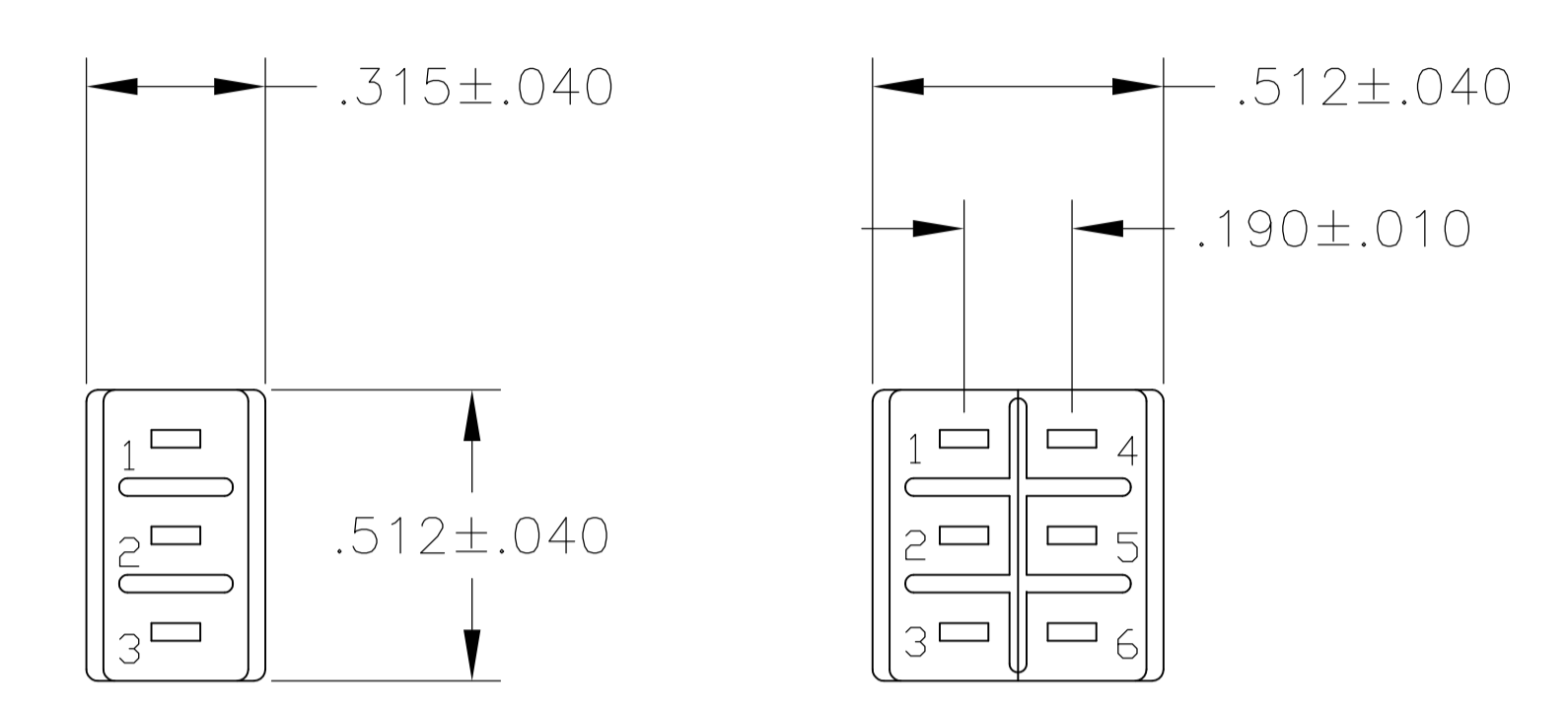
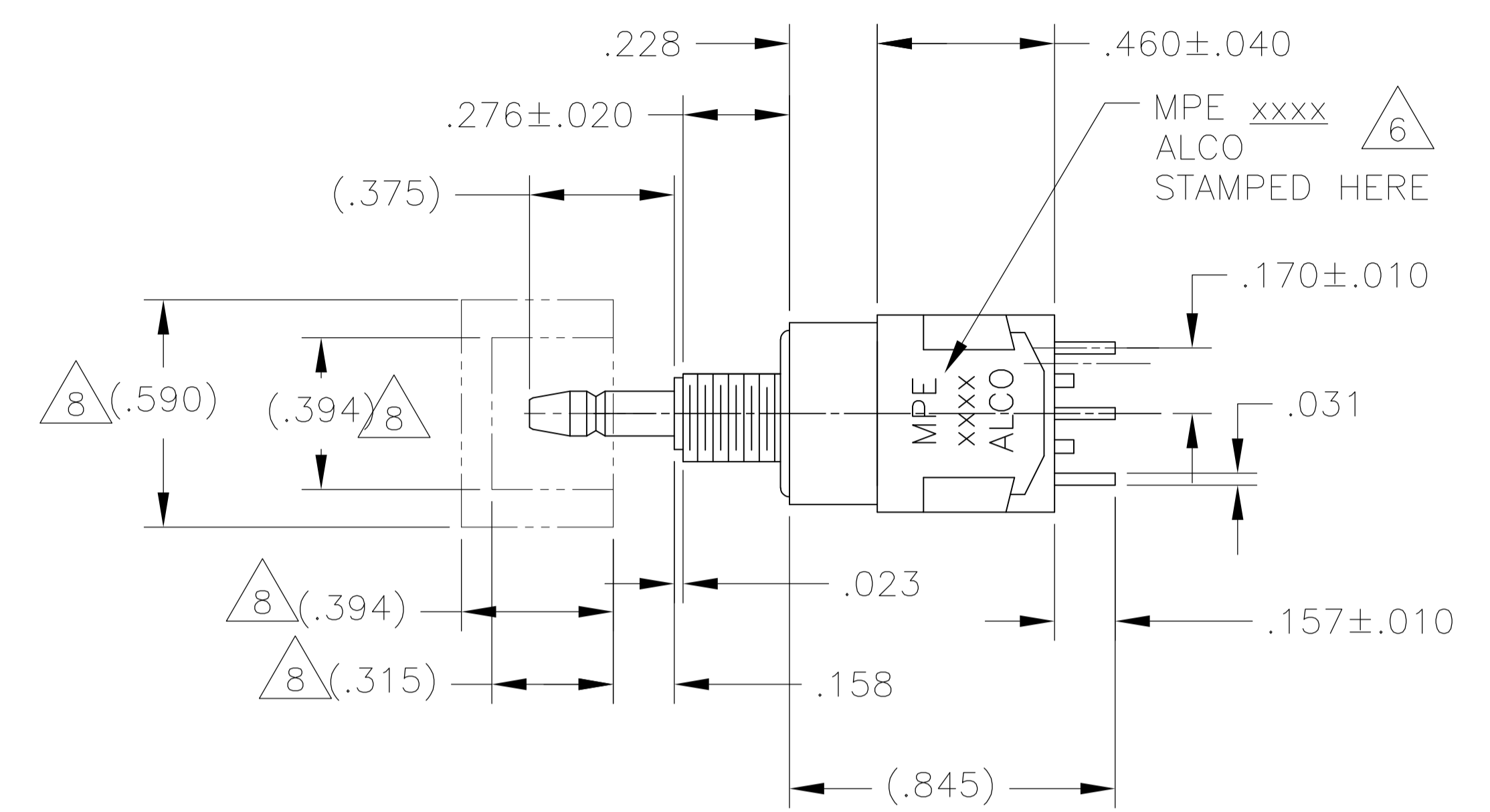

MPE-106 MPE-206

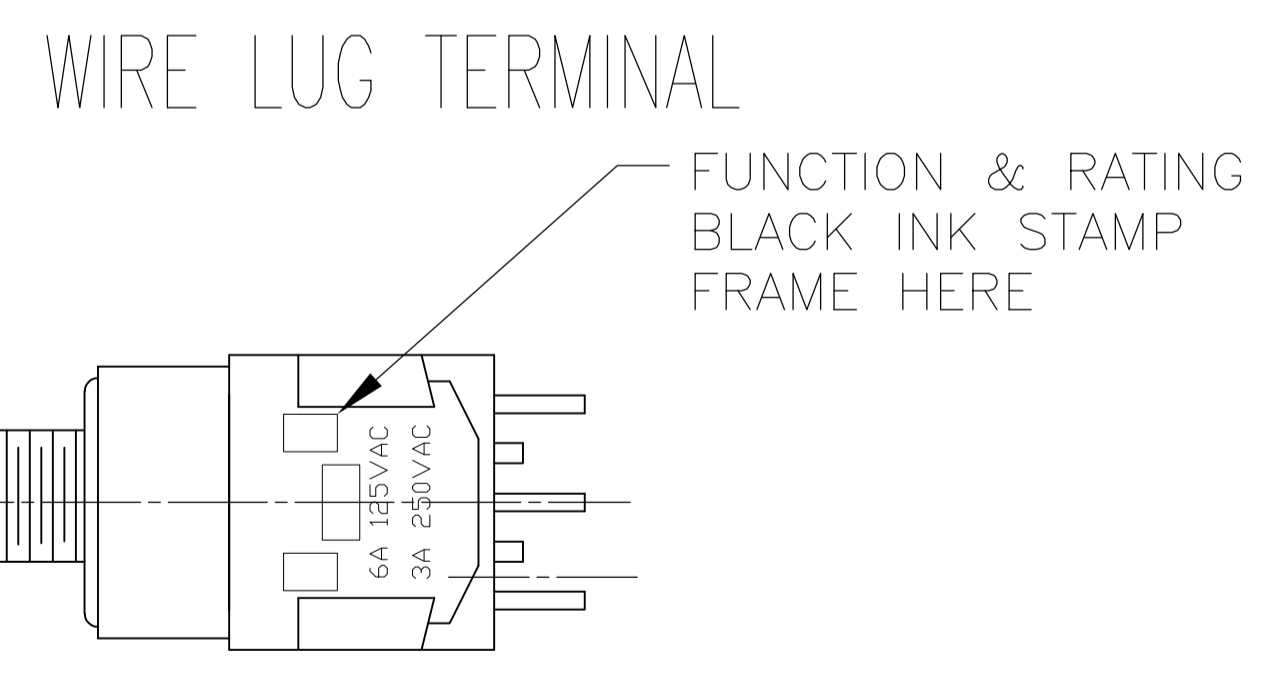
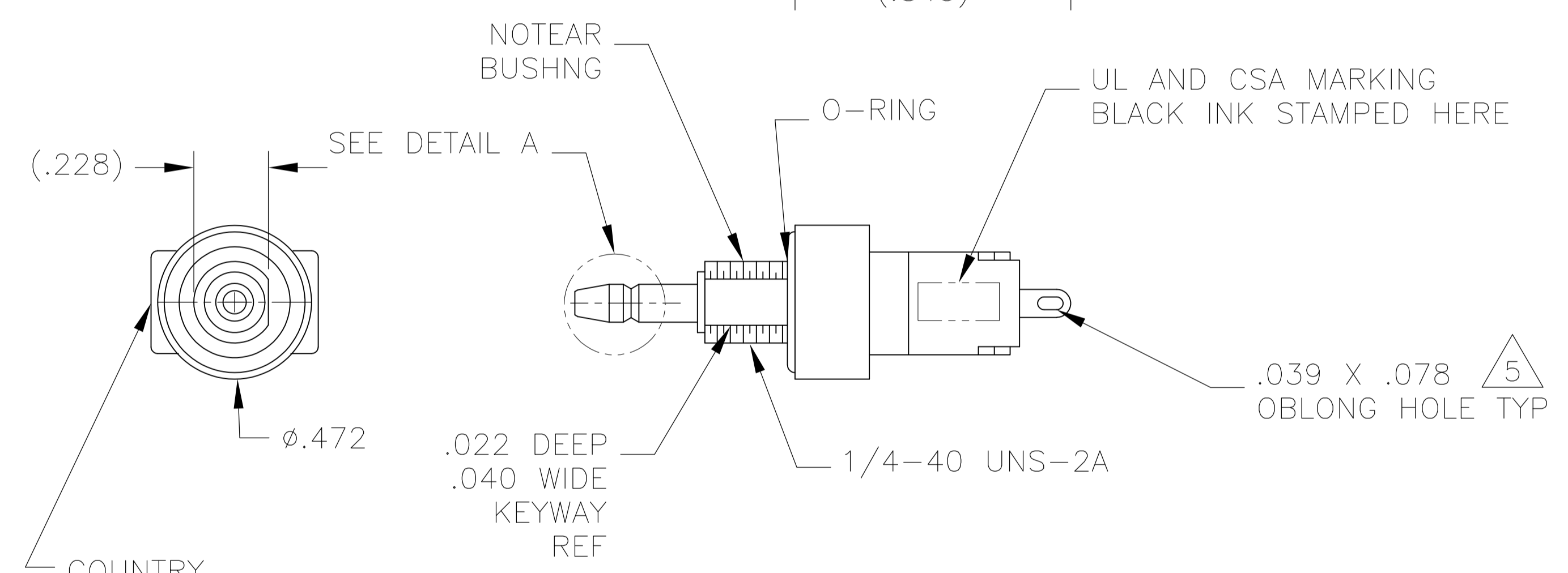

THIS DRAWING IS A CONTROLLED DOCUMENT.		DIN M. BINNER 15NOV04	Tyco Electronics Corporation Harrisburg, PA	
DIMENSIONS: INCHES		CHK M. ZITTO 15NOV04	NAME ALCOSWITCH GREEN SERIES PUSHBUTTON SWITCH, MPE SERIES	
TOLERANCES UNLESS OTHERWISE SPECIFIED:		APVD M. ZITTO 15NOV04	PRODUCT SPEC	
0. PLC ± -		APPLICATION SPEC		
1. PLC ± -		SIZE		
2. PLC ± -		CAGE CODE		
3. PLC ± .012		DRAWING NO		
4. PLC ± -		RESTRICTED TO		
ANGLES ± -		A1 00779		
MATERIAL		WEIGHT		
FINISH		SCALE 3:1		
		SHEET 2 OF 3		
		REV A1		

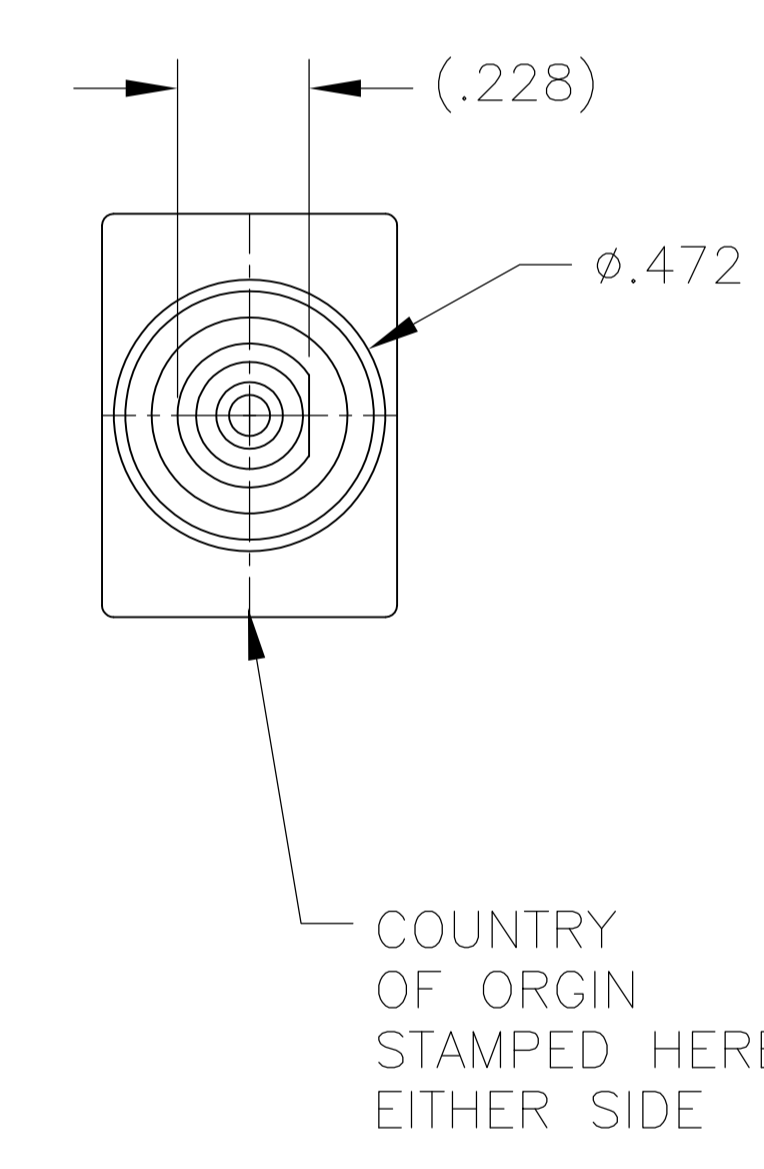
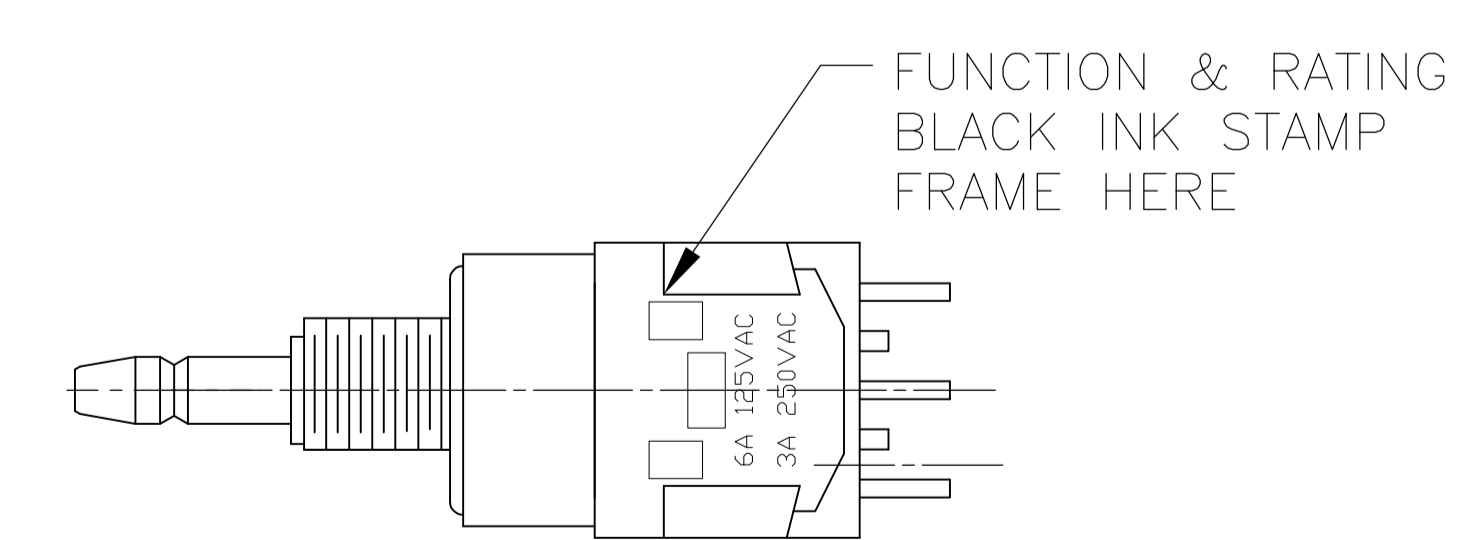
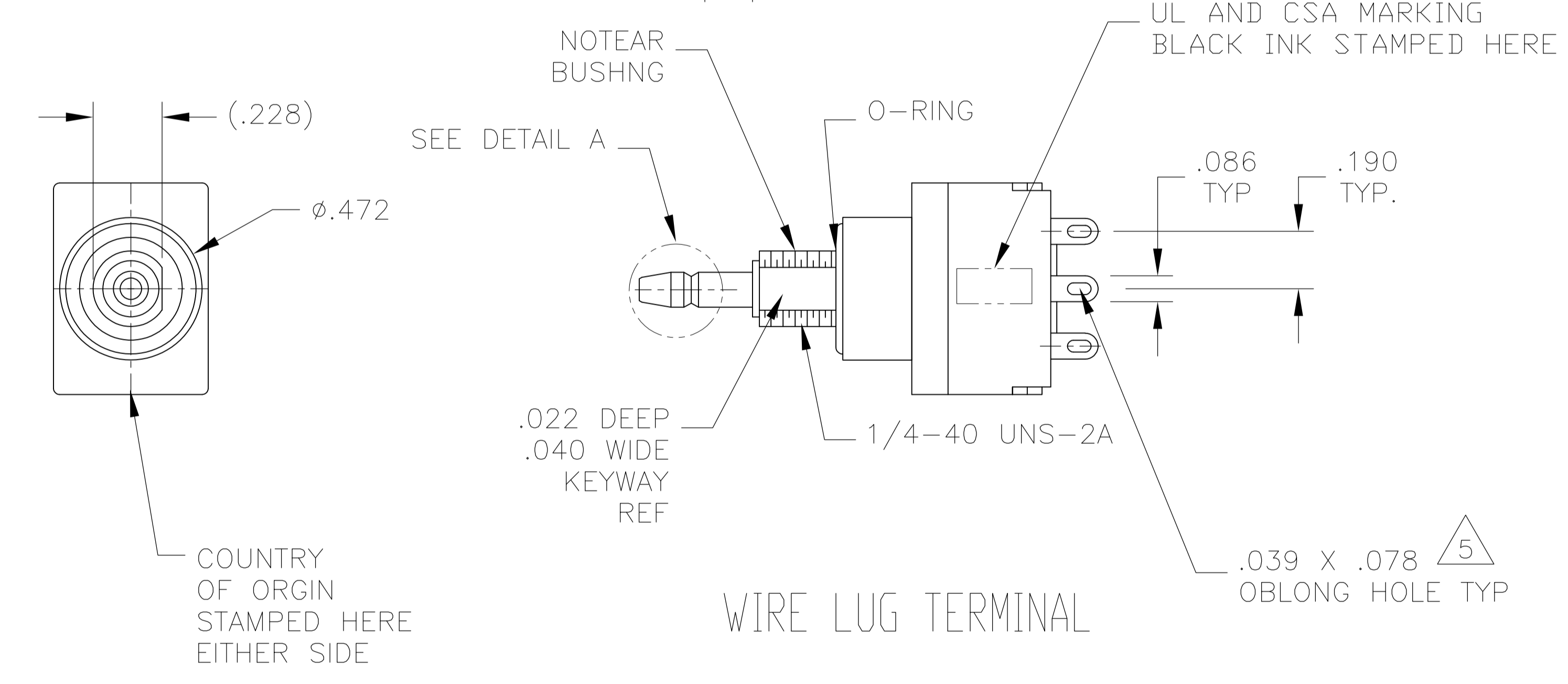
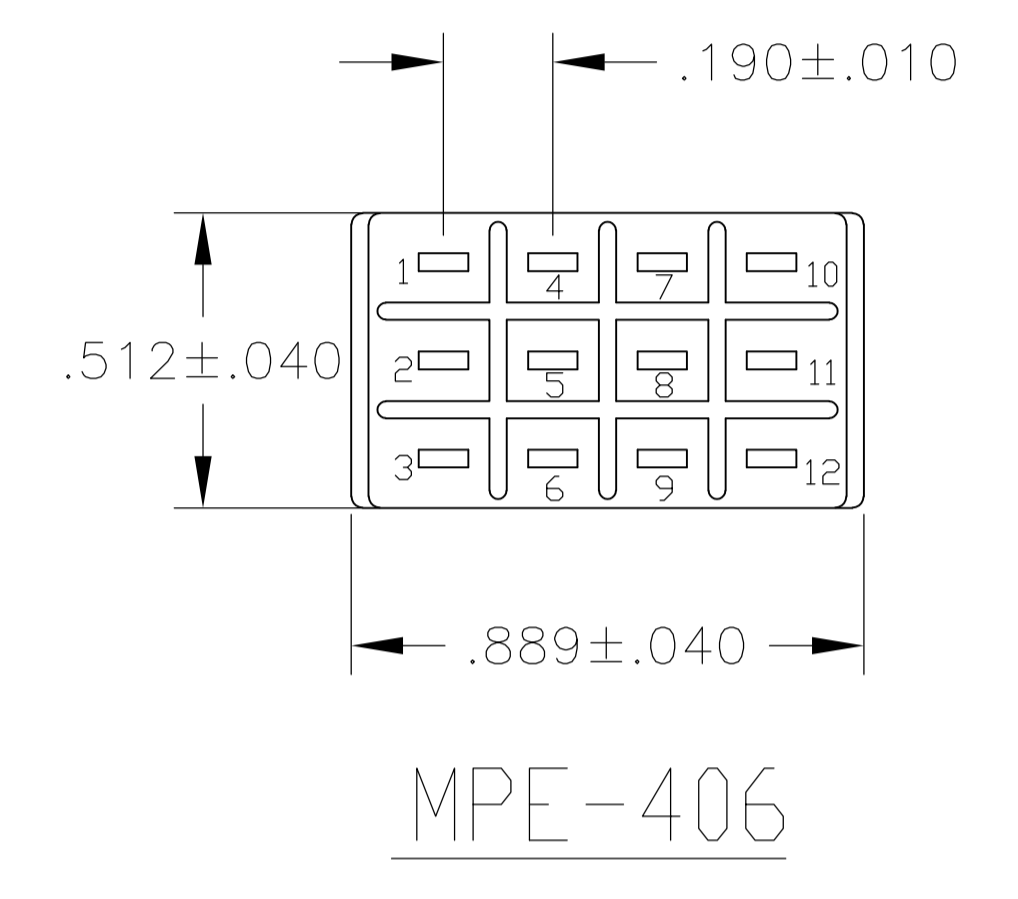
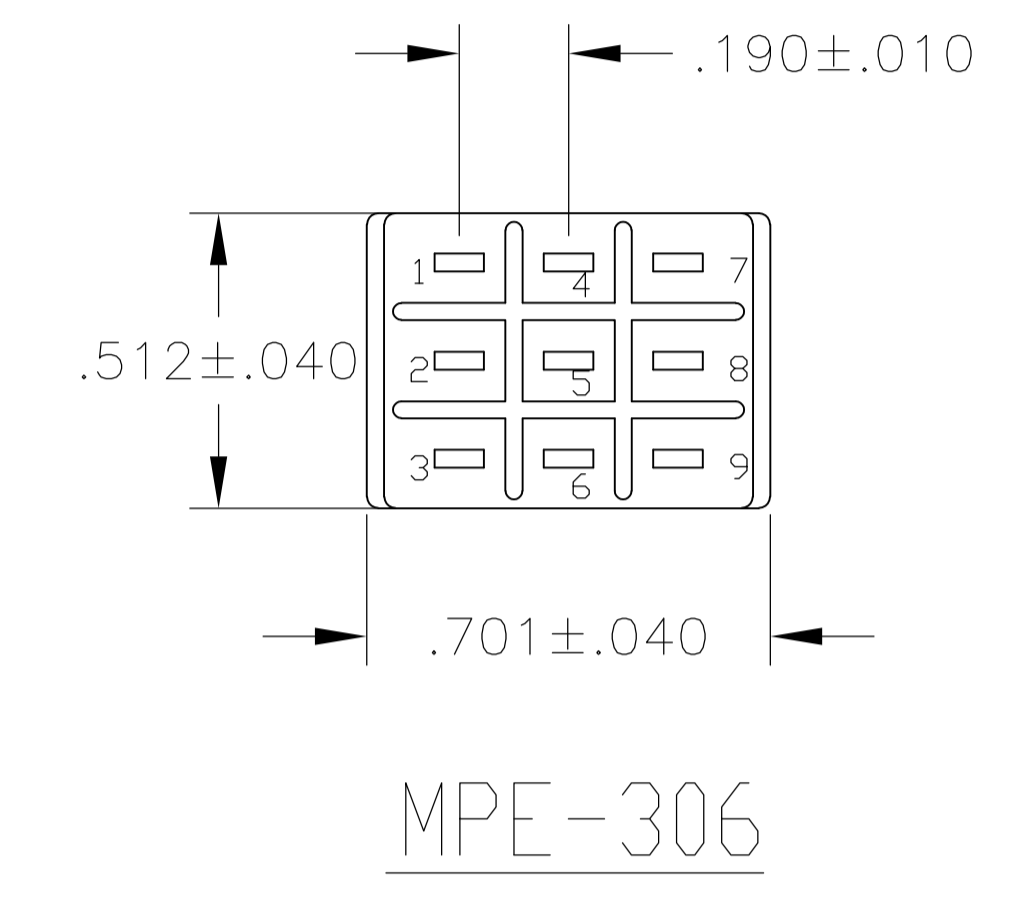
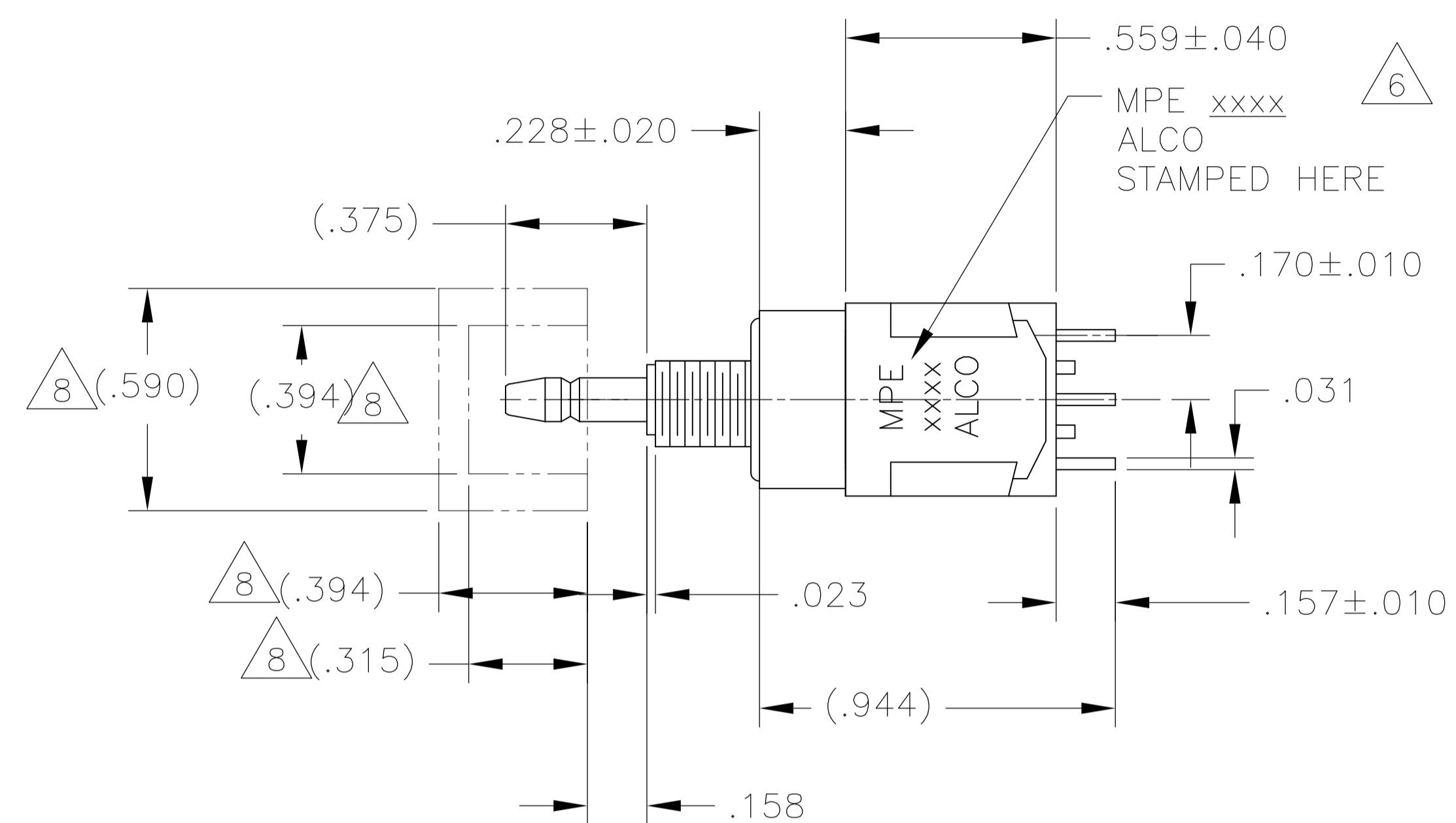

THIS DRAWING IS A CONTROLLED DOCUMENT.		DIN	M. BINNER	15NOV04	Tyco Electronics Corporation Harrisburg, PA
DIMENSIONS: INCHES		CHK	M. ZITTO	15NOV04	
TOLERANCES UNLESS OTHERWISE SPECIFIED:		APP'D	M. ZITTO	15NOV04	NAME
0. PLC	± .01	PRODUCT SPEC		ALCOSWITCH GREEN SERIES PUSHBUTTON SWITCH, MPE SERIES	
1. PLC	± .01	APPLICATION SPEC		-	
2. PLC	± .01	WEIGHT		-	
3. PLC	± .012	SIZE		A1	
4. PLC	± .01	CAGE CODE		00779	
ANGLES	± .01	DRAWING NO		4-1437567-3	
MATERIAL		FINISH		CUSTOMER DRAWING	
		SCALE		3:1	
		SHEET		3 OF 3	
		REV		A1	