

THIS DRAWING IS UNPUBLISHED. RELEASED FOR PUBLICATION
 © COPYRIGHT BY TYCO ELECTRONICS CORPORATION. ALL RIGHTS RESERVED.

Loc		DIST		REVISIONS			
P	LTR	DESCRIPTION	DATE	DWN	APVD		
H	-	H4	REVISED PER ECO-10-001916	02FEB2010	JY	SY	

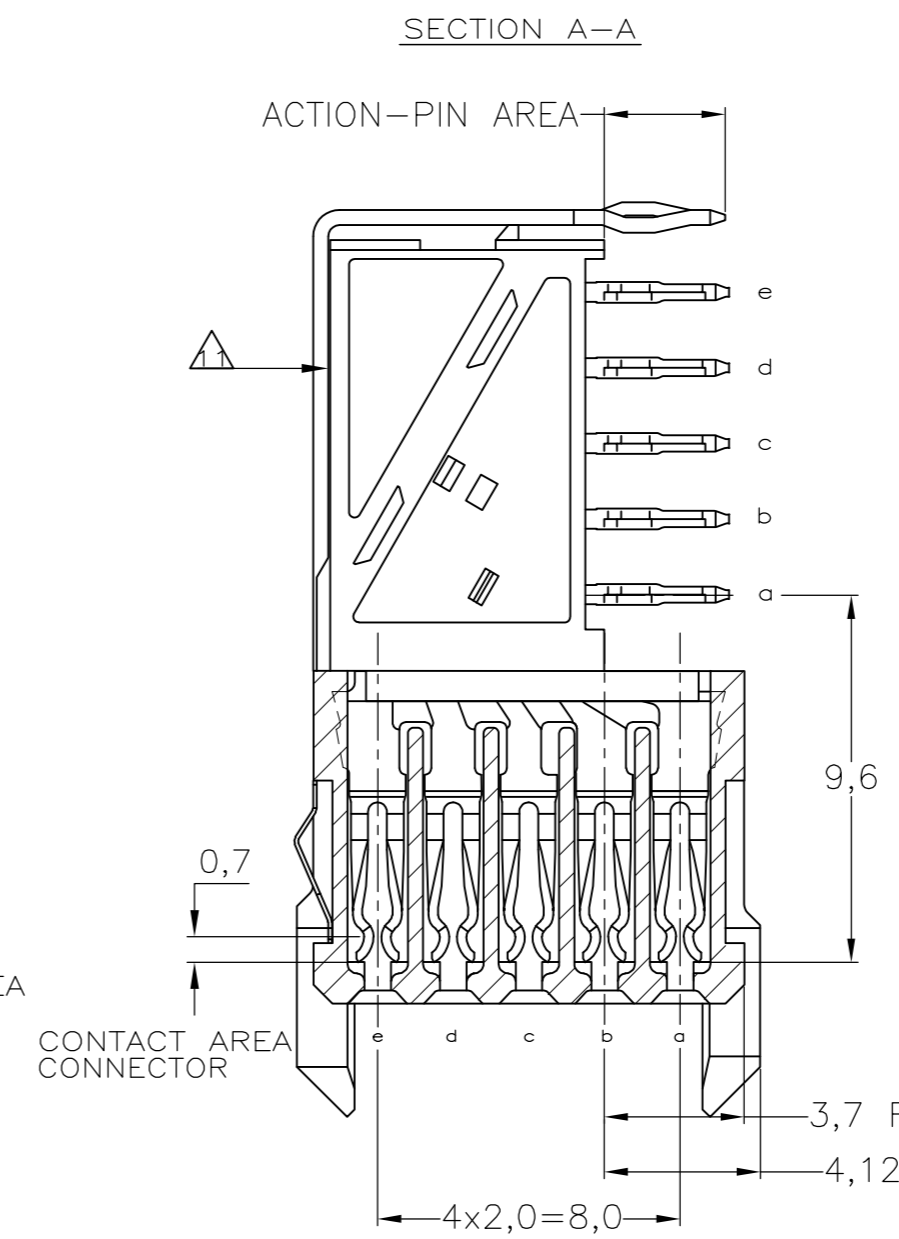

- NOTES:
- △ MATERIAL CONTACTS; PHOSPHORBRONZE
 - △ MATERIAL HOUSING; GLASSFILLED POLYESTER (GRAY)
 - △ GENERAL PLATING SPECIFICATION: UNDERPLATING (ENTIRE CONTACT): 1,27µm NICKEL MIN. AND ACTION PIN: 0,5µm TIN-LEAD MIN. FOR PLATING OF MATING SURFACES SEE APPLICABLE SPECIFICATION REFERENCE FOR EACH DASH NUMBER.
 - △ CONFORMS TO ALL TESTING ACCORDING IEC 61076-4-101 PERFORMANCE LEVEL 2.
 - △ CONFORMS TO ALL TESTING ACCORDING IEC 61076-4-101 PERFORMANCE LEVEL 1.
 - △ CONNECTOR TESTED AND QUALIFIED AGAINST TELCORDIA GR-1217-CORE QUALITY LEVEL III, CENTRAL OFFICE APPLICATIONS.
 - △ CONNECTOR LUBRICATED WITH TELCORDIA GR-1217-CORE APPROVED LUBRICANT.
 - △ PLATING SHIELD:
CONTACT AREA: 0,76µm Au MIN.
ACTION PIN : 0,5µm SnPb MIN.
REMAINDER : Ni
 - △ ASSEMBLY PRINTED WITH P/N AND DATECODE. THE MARKING CAN APPEAR ON THE FRONT SIDE OR BACK SIDE.
 - △ HOLE PATTERN FOR FEMALE CONNECTOR TYPE A 110 PLATED-THROUGH HOLES AT 2x2mm SQUARE GRID
 - △ ROW "f" 13 PLATED THROUGH HOLES FOR UPPERSHIELD
 - △ SHIELD MOUNTED ON CONNECTOR WITH DOUBLE SIDED ADHESIVE TAPE OR ADHESIVE
 - △ AREA RESERVED FOR KEYING PART (BASIC P.N. 100526) 13 BASIC P.N. LOWERSHIELD: 338108
 - △ 0.76µm MIN GOLD PLATING AT MATING SURFACES.

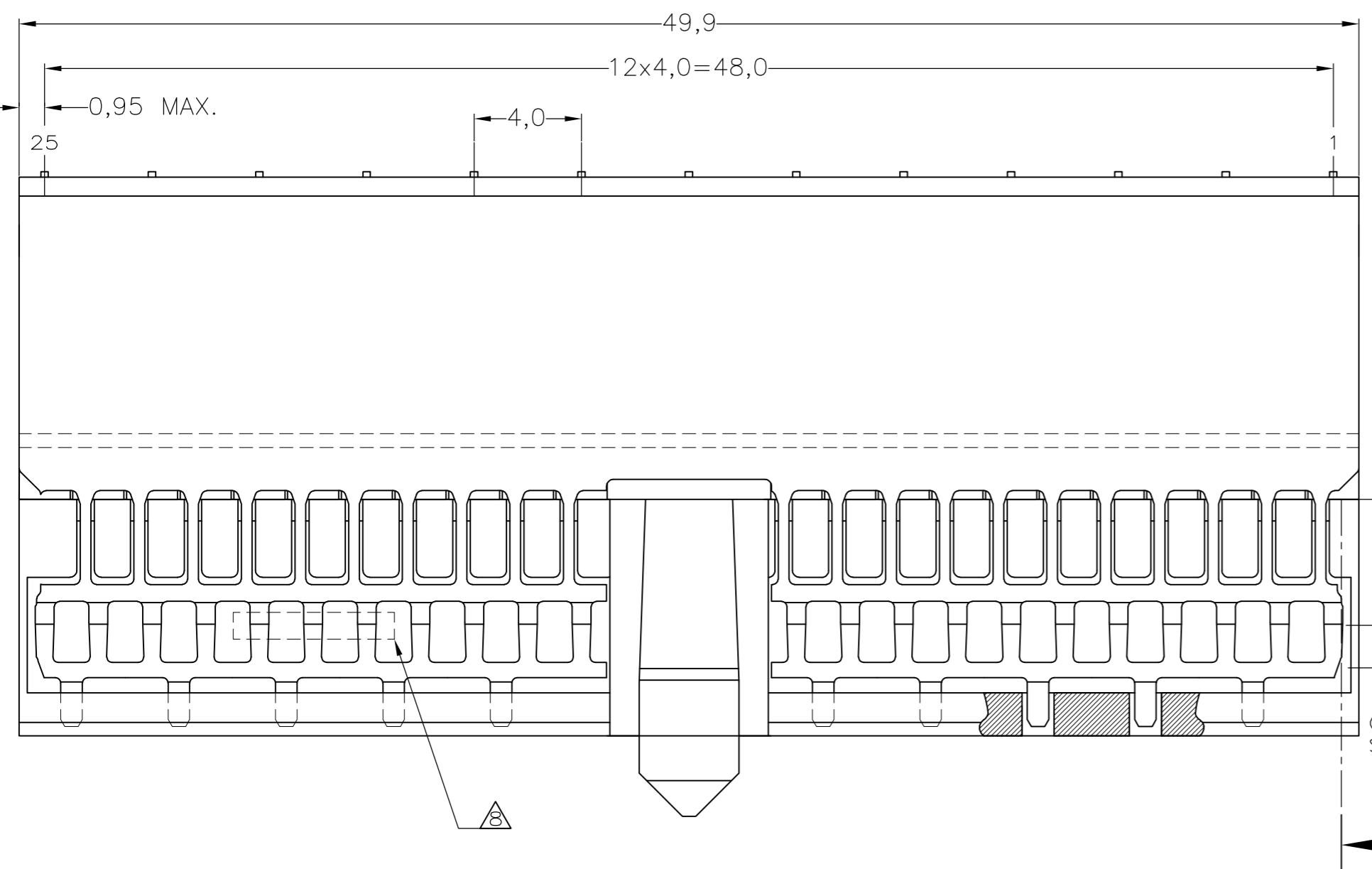
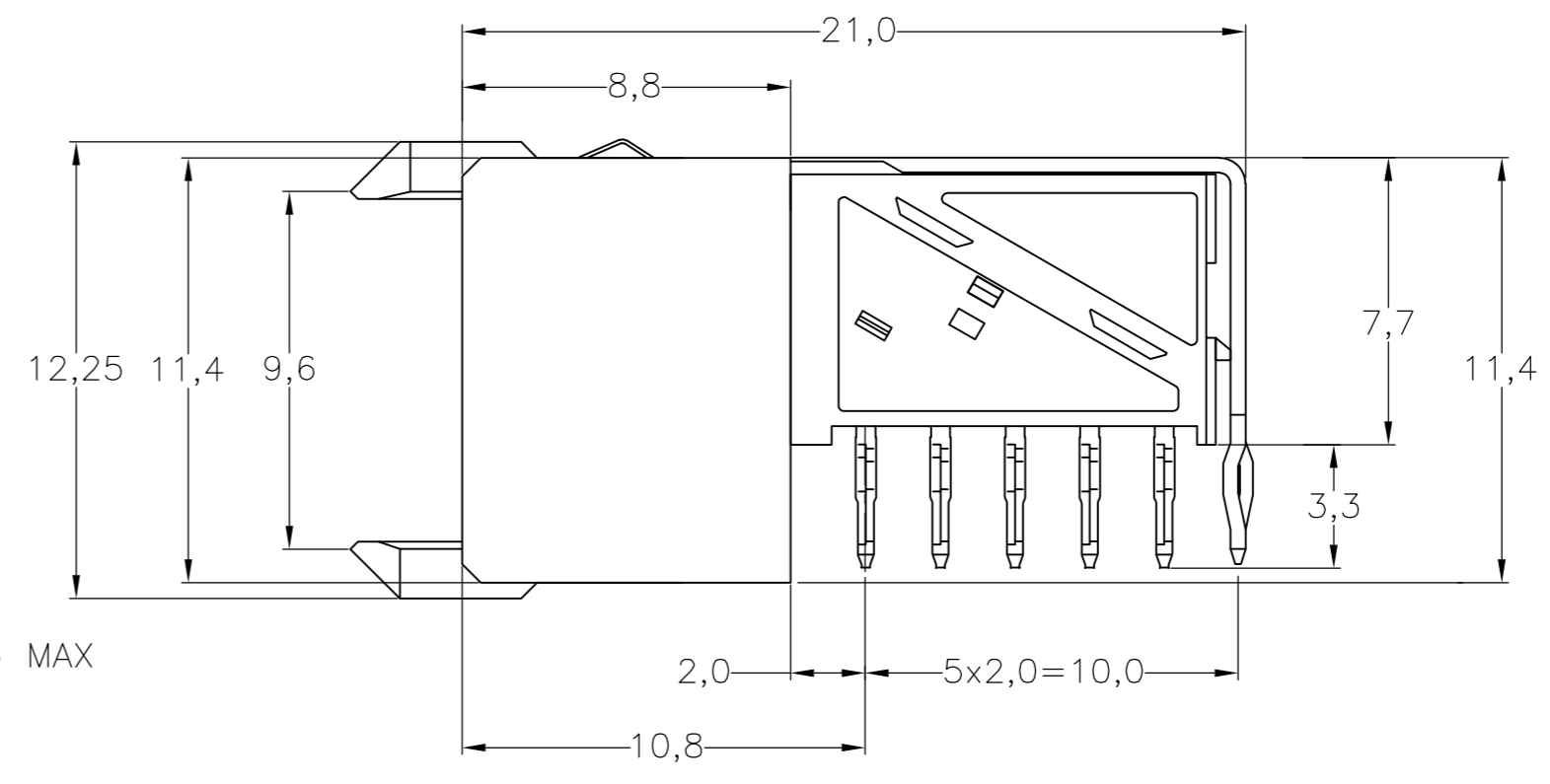
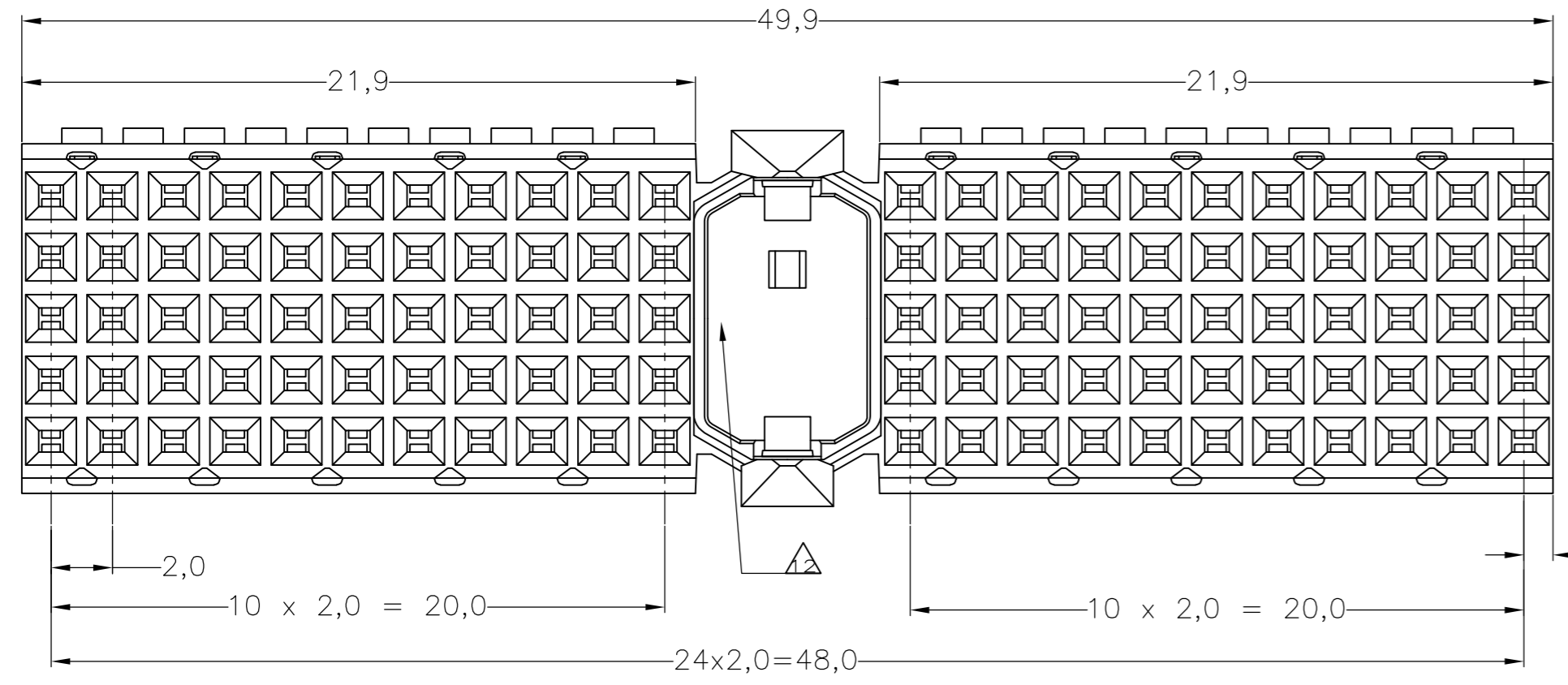

COMPONENT SIDE AS SHOWN
 RECOMMENDED PCB-HOLE LAY-OUT
 SCALE 2,5:1

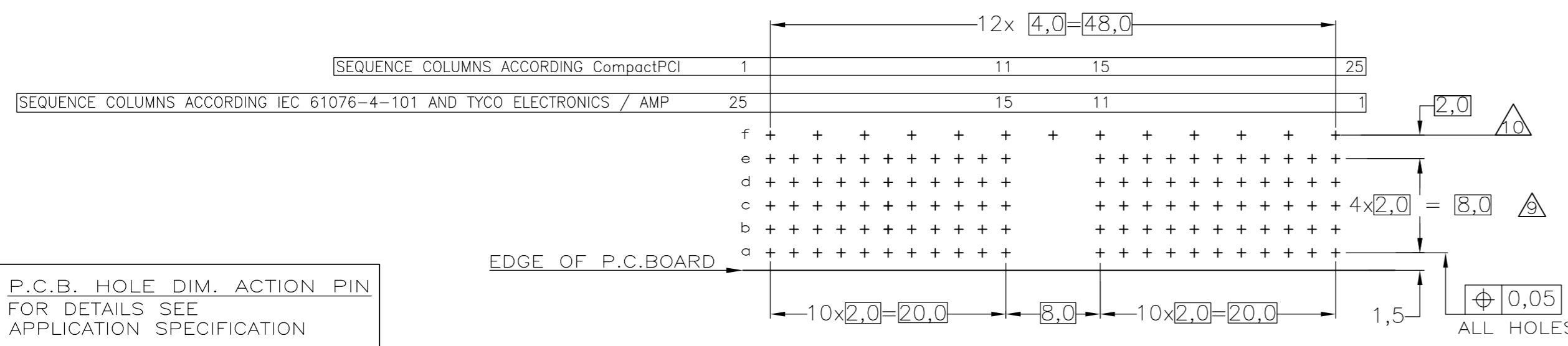

P.C.B. HOLE DIM. ACTION PIN
 FOR DETAILS SEE
 APPLICATION SPECIFICATION

FINISH	MATERIAL	PARTNUMBER
△ △ △ △ △	△	3-352068-0
△ △ △ △ △	△	352068-9
△ △ △ △ △	△	352068-4
△ △ △ △ △	△	352068-1

THIS DRAWING IS A CONTROLLED DOCUMENT.

DWN	D. TRUREN	20JAN97		Tyco Electronics Corporation	
CHK	-	-		s-HertogenBosch, Netherlands,	
APVD	-	-	NAME	Z-PACK 2MM HM	
PRODUCT SPEC	108-19082		TYPE A - 25 COLUMNS		
APPLICATION SPEC	114-19029		PRE-SHIELDED RECEPTACLE		
WEIGHT	-	-	SIZE	CAGE CODE	DRAWING NO
CUSTOMER DRAWING	-	-	A2	00779	C=352068
SCALE			NTS	SHEET	1 OF 1
REV			H4		