

AMP Power Taps

Product Facts

- **ACTION PIN** contacts eliminate soldering
- Provides high current, separable connection to pc board traces
- Wire-to-board connection using common terminals
- All metal-to-metal assembly for long-term integrity
- Standard DIP outlines (7.62 x 2.54 [.300 x .100]), 10 positions, and 6.35 x 3.18 [.250 x .125], 6 and 10 positions, plus high current versions on 10.16 x 5.08 [.400 x .200] footprint in 4 and 6 positions, 7.62 x 2.54 [.300 x .100] in 8 positions, and both 2 and 3 position in-line 2.54 [.100] tab taps
- Low resistance interface
- Internally threaded tap to secure screw to terminal
- Anti-rotational embossments hold wire and terminal in place
- Standard Power Taps rated at 2.5 amps per pin — 6 position 15 amps, 10 position 25 amps current carrying capability
- High Current Power Taps rated at up to 5 amps per pin — 2 position 10 amps, 3 position 15 amps, 4 and 6 position 20 amps and 8 position 40 amps
- 30 amp inverse sex Power Tap

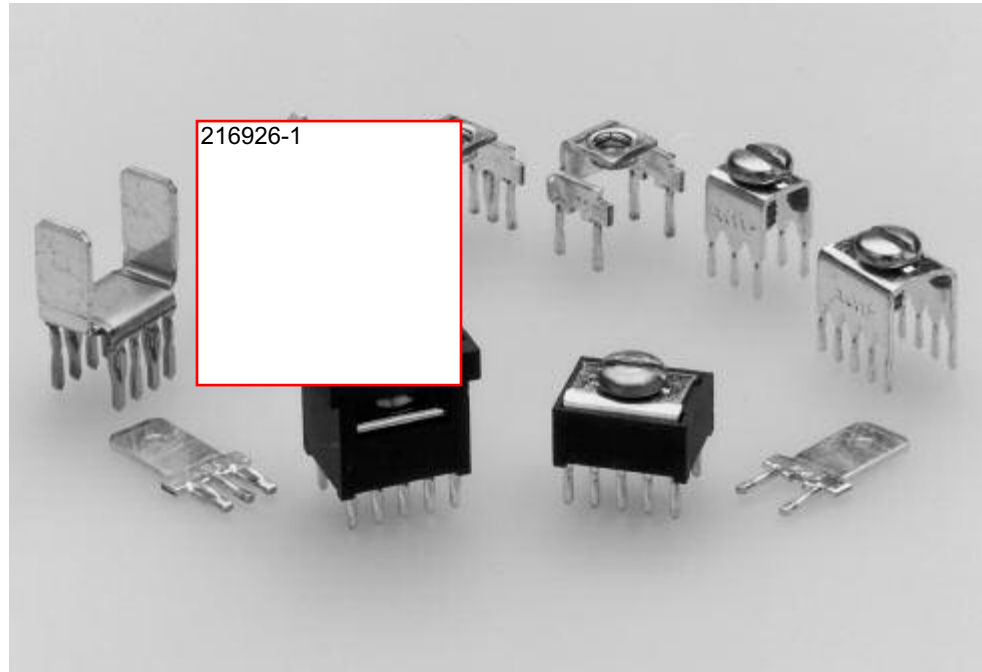

AMP Power Taps are designed for the growing need for power to printed circuit board applications required in today's electronic industry. The taps provide a high current, separable connection to a pc board. Pin configuration is of the standard DIP outline with 7.62 x 2.54 [.300 x .100] or 6.35 x 3.18 [.250 x .125] for the Standard versions, plus 10.16 x 5.08 [.400 x .200], 7.62 x 2.54 [.300 x .100] and in-line spacing for the High Current versions.

ACTION PIN contacts provide a low resistance interface with tin-plated through holes in the pc board, thereby eliminating the need for soldering.

The variety of available power taps allow for various installation schemes. The Uninsulated Tap and Low Profile Tap can be used in bus bar pattern. The High Profile and Low Profile Taps offer insulation protection from other components. The High Current versions provide a greater power

density option with current ratings from 10 amps on the 2 position in-line 6.35 [.250] tab tap up to 40 amps on the 8 position dual 6.35 [.250] tab tap.

All AMP Power Tap configurations are easily inserted into the pc board with a simple Tyco Electronics or customer supplied tool.

AMP Power Taps (Continued)

Material and Finish

Connector Body and Lid — Nylon, 105°C 94V-0 rated

Contact — Copper alloy, bright tin-lead or tin plated

Screw — Plated steel

Electrical and Mechanical Characteristics

Resistance — 2 milliohms, max. (stud hole to ACTION PIN contact)

Insertion Force — 40 lbs. [177.9N], max. per pin

Retention Force — 7 lbs. [31.1N], min. per pin

Technical Documents

Product Specification — 108-11030 Tap, Power Distribution

Application Specification — 114-11000 Tap, Power Distribution

Handbook — 5697 Guide to Application of ACTION PIN Connectors

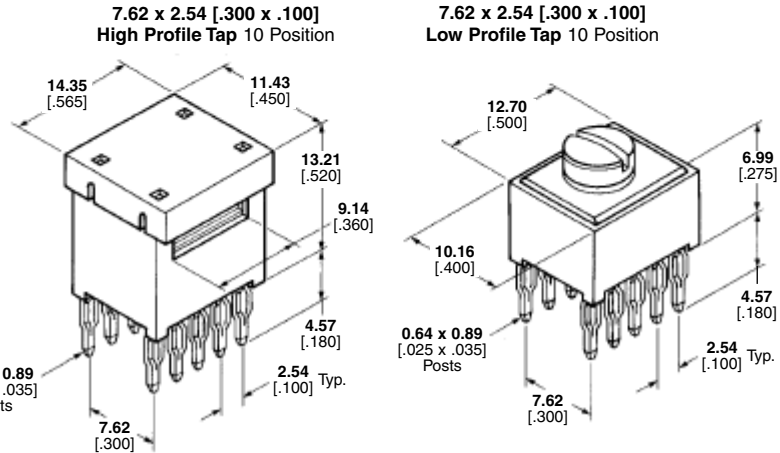
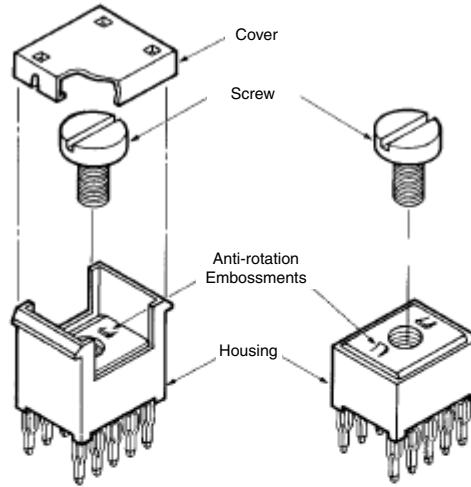

Tap Version	PCB Thickness	Description	Screw Hole Size	Part Number	
				Tin Lead	Tin
High Profile	1.57-3.18 .062-.125	Housing and Contact Assembled With Screw ^{1,2}	6-32	55557-4 ♦	5055557-4
Low Profile	1.57-3.18 .062-.125	Housing and Contact Assembled With Screw ²	6-32	55556-4 ♦	5055556-4
Low Profile	1.57-3.18 .062-.125	Housing and Contact Assembled With Screw ^{2,3}	6-32	55673-2 ♦	5055673-2
Low Profile	1.57-3.18 .062-.125	Housing and Contact Assembled Without Screw	M4	55556-9 ♦	5055556-9

¹Cover not Assembled

²Screw not Assembled

³No Anti-rotational Embossments

For Standard Threaded Taps Only

Recommended PC Board Layout

Drilled Hole Diameter— 1.15±0.03 [.0453±.001]

After Plating

0.94-1.09 [.037-.043]

After Reflow—

0.91-1.09 [.036-.043]

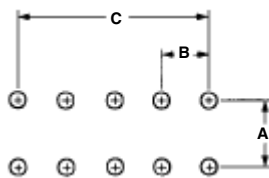

Size	Dimensions		
	A	B	C
7.62 x 2.54 .300 x .100 10 Position	7.62 .300	2.54 .100	10.16 .400
6.35 x 3.18 .250 x .125 6 Position	6.35 .250	3.18 .125	6.35 .250
6.35 x 3.18 250 x .125 10 Position	6.35 .250	3.18 .125	12.7 .500

Note: Part Numbers are RoHS compliant except: ♦ Indicates non-RoHS compliant.

AMP Power Taps (Continued)

Material and Finish

Contact—Copper alloy, post plated bright tin-lead or tin plated
Screw—Stainless steel, passivated

Electrical and Mechanical Characteristics

Resistance — 2 milliohms, max. (stud hole to ACTION PIN contact)
Insertion Force — 40 lbs. [177.9N] max. per pin
Retention Force — 7 lbs. [31.1N] min. per pin

For Recommended PC Board Layout, see page 132.

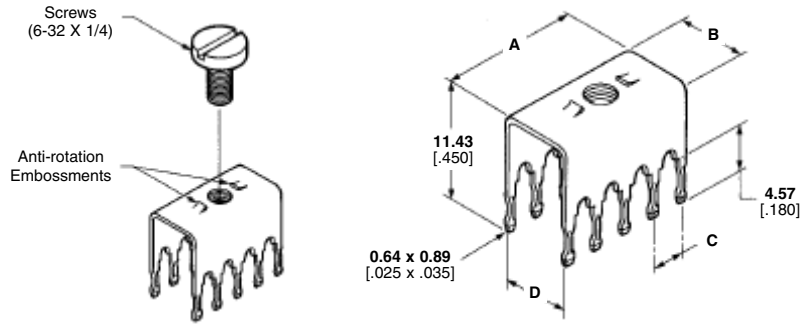

Size	PCB Thickness	Dimensions				Description	Screw Size	Part Number	
		A	B	C	D			Tin Lead	Tin
7.62 x 2.54 .300 x .100 10 Position	1.57-3.18 .062-.125	11.18 .440	8.26 .325	2.54 .100	7.62 .300	Without Screw	6-32	55558-3	5055558-3
						With Screw	6-32	55558-4	5055558-4
6.35 x 3.18 .250 x .125 6 Position	1.57-3.18 .062-.125	8.13 .320	6.99 .275	3.18 .125	6.35 .250	Without Screw	6-32	55323-5	5055323-5
						With Screw	6-32	55323-9	5055323-9
6.35 x 3.18 .250 x .125 10 Position	1.57-3.18 .062-.125	14.48 .570	6.99 .275	3.18 .125	6.35 .250	Without Screw	6-32	55232-6	5055323-6
						With Screw	6-32	1-55323-0	1-5055323-0

High Current* Power Taps

*Up to 20 amps

Material and Finish

Contact — Phosphor bronze, tin-lead or tin plated
Screw — Stainless steel, passivated
Washer — Stainless steel

Electrical and Mechanical Characteristics

Current Rating — 20 amperes max.
Insertion Force — 40 lbs. [180N] max. per pin
Retention Force — 7 lbs. [30N] min. per pin

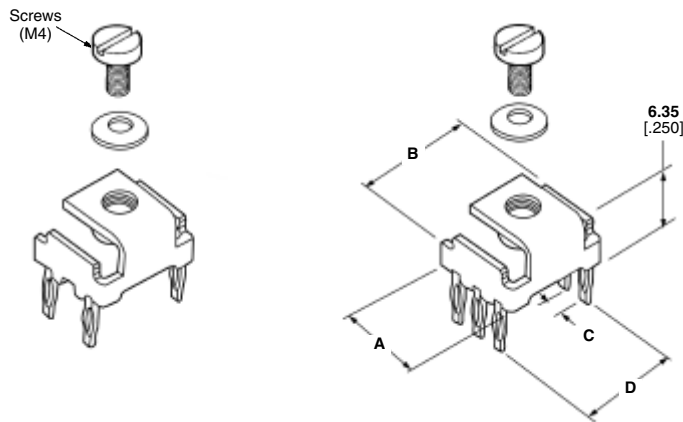

Size	PCB Thickness	Dimensions				Description	Part Number	
		A	B	C	D		Tin Lead	Tin
4 Position	1.57-3.18 .062-.125	9.09 .358	10.95 .431	5.08 .200	10.16 .400	With Screw, Washer	213815-1 ♦	5213815-1 ♦
						Without Screw	216906-1 ¹	—
6 Position	1.57-3.18 .062-.125	9.09 .358	10.95 .431	2.54 .100	10.16 .400	With Screw, Washer	213816-1 ♦	5213816-1 ♦
						Without Screw	216907-1 ¹	—

¹No Anti-rotation Embossments featured on High Current Taps. Therefore, if application requires product supplied without washer and screw, use of lock-washers with a high surface contact area are strongly recommended.

For High Current and FASTON Taps

Use with Hand Press **677430-1**

Recommended PC Board Layout

Drilled Hole Diameter—
1.60±0.03 [.063±.001]
Cu Thickness—
0.03-0.08 [.001-.003]
SnPb Thickness—
0.004 min. [.0002 min.]

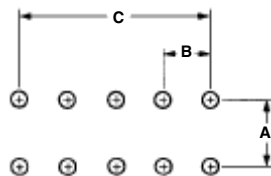

Finished Hole—
1.36-1.54 [.054-.061]
After Reflow—
1.36-1.54 [.054-.061]

Type	A	B	C
4 Position	10.16 .400	5.08 .200	5.08 .200
6 Position	10.16 .400	2.54 .100	5.08 .200
I	—	5.08 .200	5.08 .200
II	—	2.54 .100	5.08 .200
III	10.16 .400	5.08 .200	5.08 .200
IV	7.62 .300	2.54 .100	7.62 .300

Note: Part Numbers are RoHS compliant except: ♦ Indicates non-RoHS compliant.

AMP Power Taps (Continued)

*Up to 5 amps per pin

**Mating Connectors
FASTON Receptacles**

Material and Finish

Contact — Phosphor bronze, post plated tin-lead or tin plated

Screw — Stainless steel, passivated

Washer — Stainless steel

Electrical and Mechanical Characteristics

Current Rating — 5 amps max. per pin

Insertion Force — 40 lbs. [180N] max. per pin

For Recommended PC Board Layout, see page 133.

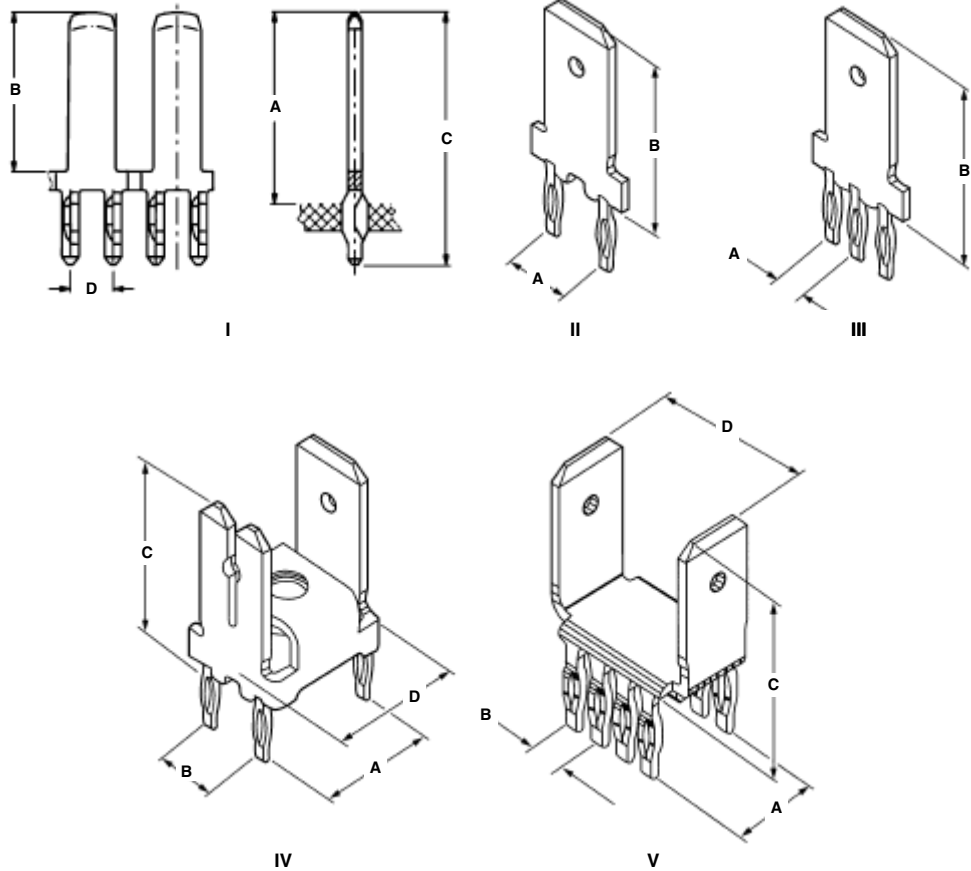

Style	PCB Thickness	Dimensions				Description	Part Number	Receptacle Mating
		A	B	C	D			
I	1.39 x 1.54 .055 x .061	13.50 .531	10.75 .423	18.50 .728	2.54 .100	2.8 x 0.80 .110 x .031 Tab	338429-2 ♦	Positive Lock
II	1.57 x 3.18 .062 x .125	5.08 .200	13.49 .531	—	—	6.35 x 0.81 .250 x .032 Tab	216926-1	Positive Lock
III	1.57 x 3.18 .062 x .125	2.54 .100	13.49 .531	—	—	6.35 x 0.81 .250 x .032 Tab	216843-1	Positive Lock
IV	1.57 x 3.18 .062 x .125	10.16 .400	5.08 .200	13.49 .531	10.95 .431	1-6.35 x 0.81 .250 x .032 Tab	216905-1 ¹	Positive Lock
						2-2.79 x 0.81 .110 x .032 Tab		
V	3.18 .125	7.62 .300	2.54 .100	12.32 .485	12.70 .500	2-6.35 x 0.81 .250 x .032 Tab	5167892-32 ♦	FASTON Rcpt.
						With Hole	167892-6 ²	Positive Lock

¹No Anti-rotation Embossments featured on High Current Taps. Therefore, if application requires product supplied without washer and screw, use of lock-washers with a high surface contact area are strongly recommended.

²Phosphor Bronze, post plated matte tin

Note: Part Numbers are RoHS compliant except: ♦ Indicates non-RoHS compliant.

AMP Power Taps (Continued)

Product Facts

- Excellent for power distribution
- For board-to-board and board-to-bus applications
- LOUVERTAC high current contact used in receptacle
- ACTION PIN compliant pcb tails for high surface area contact with plated through hole
- Receptacle fits onto standard DIP 7.62 x 2.54 [.300 x .100] footprint
- Press-fit receptacle needs simple “flat-rock” tooling to install
- Accommodates board thickness from 1.37 to 3.18 [.054 to .125]
- Insulated body rated 105°C 94 V-0
- Blindmate capability (tolerance: ± 3.18 [± .125] in X and Y axes)
- Perpendicular board stacking
- Silver or Gold plated
- UL recognition at 35 Amps

Material and Finish

Housing — Thermoplastic black
Body — Zinc Alloy
Contact — Bronze Alloy
Pin — Brass Alloy

Technical Documents

Product Specification — 108-1624 and 108-1624-1
Application Specification — 114-11000 Tap, Power Distribution

Compatible with Z-PACK 2mm HM product family.

Vertical Receptacle

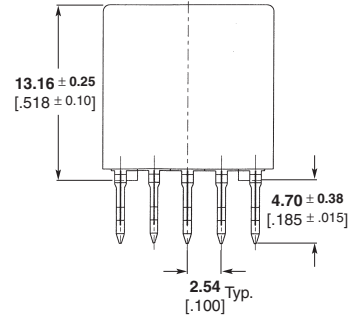
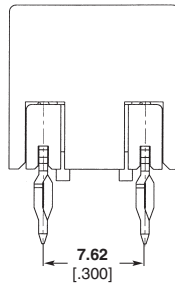
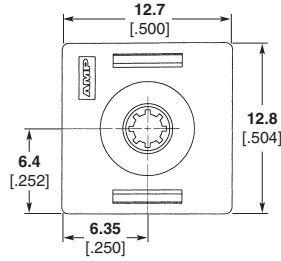

Recommended PC Board Layout

Right Angle Pin

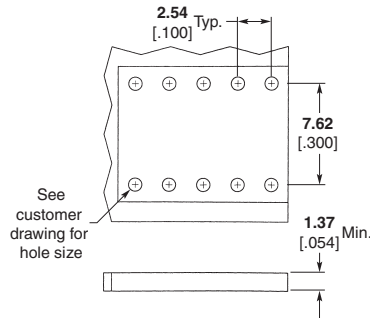
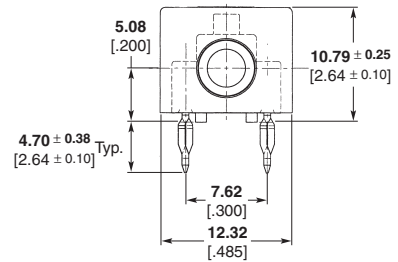
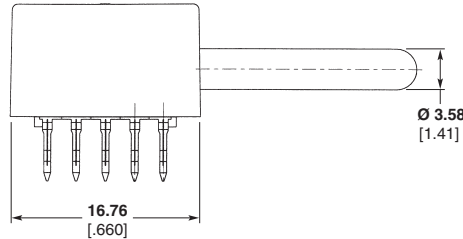

Recommended PC Board Layout

Description	Plating	Part Number
Right Angle Pin	Gold	796137-2
Vertical Receptacle	Gold	796138-2

Note: Part Numbers are RoHS compliant except: ♦ Indicates non-RoHS compliant.

AMP Power Taps (Continued)

**Application Tooling/
PCB Layout**

**For Standard Threaded
Taps Only**

**Recommended PC Board
Layout**

Drilled Hole Diameter—
.0453±.001 [1.15±0.03]

After Plating

.037-.043 [0.94-1.09]

After Reflow—

.036-.043 [0.91-1.09]

**Installation and Extraction
Tooling**

Impact Insertion Tool Number

313102-1

(Insertion Tip No. 58133-1 required)

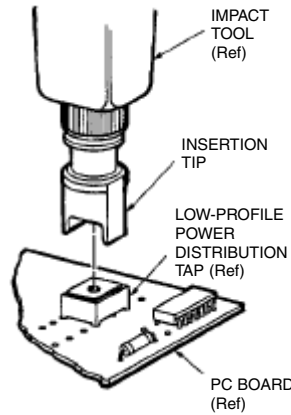
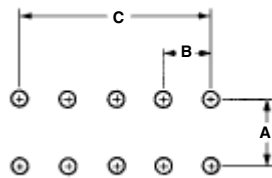

Extraction Tool Number 68380-1

Size	Dimensions		
	A	B	C
.300 x .100 7.62 x 2.54 10 Position	.300 7.62	.100 2.54	.400 10.16
.250 x .125 6.35 x 3.18 6 Position	.250 6.35	.125 3.18	.250 6.35
250 x .125 6.35 x 3.18 10 Position	.250 6.35	.125 3.18	.500 12.7

**For High Current and
FASTON Taps**

Use with Hand Press **677430-1**

**Recommended PC Board
Layout**

Drilled Hole Diameter—
.063±.001 [1.60±0.03]

Cu Thickness—

.001-.003 [0.03-0.08]

SnPb Thickness—

.0002 min.[0.004 min.]

Finished Hole—

.055-.061 [1.39-1.54]

After Reflow—

.054-.061 [1.36-1.54]

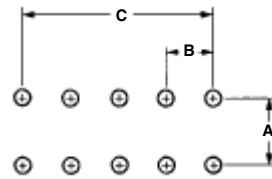

Type	A	B	C
4 Position	.400 10.16	.200 5.08	.200 5.08
6 Position	.400 10.16	.100 2.54	.200 5.08
I	—	.200 5.08	.200 5.08
II	—	.100 2.54	.200 5.08
III	.400 10.16	.200 5.08	.200 5.08
IV	.300 7.62	.100 2.54	.300 7.62

Installation Tooling

Type	Part Number	Upper Tool	Lower Tool
High Current 4 & 6 Positions	216906-1 216907-1	432848-1	433600-2 or 432130-2
High Current Style I, II	216926-1 216843-1	432845-1	433600-2 or 432130-2
High Current Style III	216905-1	432847-1	433600-2 or 432130-2
High Current Style IV	5167892-3 167892-6	432849-1	433600-2 or 432130-2

Note: Part Numbers are RoHS compliant except: ♦ Indicates non-RoHS compliant.