

THIS DRAWING IS UNPUBLISHED. RELEASED FOR PUBLICATION 20
 © COPYRIGHT 20 BY TYCO ELECTRONICS CORPORATION. ALL RIGHTS RESERVED.

LOC	DIST	REVISIONS			
P	LTR	DESCRIPTION	DATE	DWN	APVD
-	-	A	REL PER ECR 09-028078	11 JAN 10	JR DD

- ⚠ MATERIALS AND FINISH:
 HOUSING: NYLON, COLOR: WHITE
 CONTACTS: COPPER ALLOY, FINISH: PRE-TINNED
 WIRE: 24 AWG, UL 1061 STYLE
- 2. MUST COMPLY WITH DIRECTIVE 2002/95/EC (ROHS)
- ⚠ PRELIMINARY - NOT FOR PRODUCTION

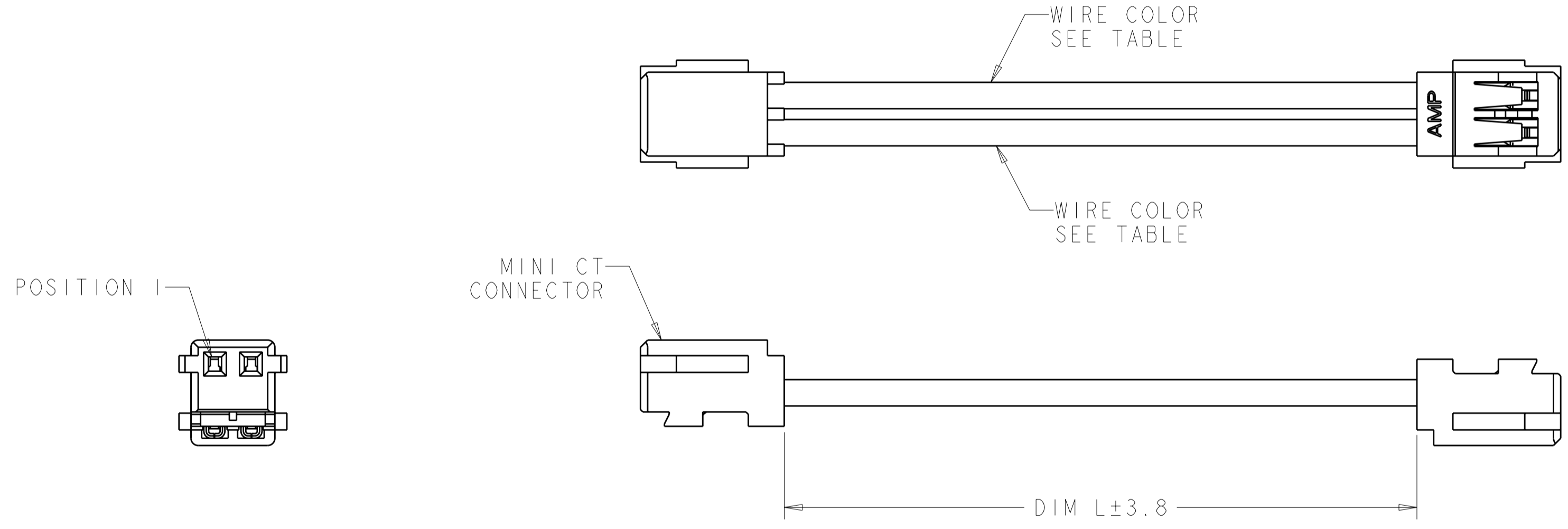

WHITE	WHITE	300.0	⚠ 3	1969342-6
WHITE	WHITE	150.0	⚠ 3	1969342-5
WHITE	WHITE	50.0		1969342-4
RED	BLACK	300.0	⚠ 3	1969342-3
RED	BLACK	150.0	⚠ 3	1969342-2
RED	BLACK	50.0	⚠ 3	1969342-1
WIRE COLOR POSITION #2	WIRE COLOR POSITION #1	DIM L		PART NO.

<small>THIS DRAWING IS A CONTROLLED DOCUMENT FOR TYCO ELECTRONICS CORPORATION. IT IS SUBJECT TO CHANGE AND THE CONTROLLING ENGINEERING ORGANIZATION SHOULD BE CONTACTED FOR THE LATEST REVISION.</small>		DWN JR RUTH 08DEC09 CHK D. DECKER 08DEC09 APVD D. DECKER 08DEC09	Tyco Electronics Harrisburg, PA 17105-3608
DIMENSIONS: mm 	TOLERANCES UNLESS OTHERWISE SPECIFIED: 0 PLC ± 1 PLC ± 2 PLC ± 3 PLC ± 4 PLC ± ANGLES ± FINISH	PRODUCT SPEC APPLICATION SPEC 114-5245 WEIGHT -	NAME CABLE ASSEMBLY MINI-CT
MATERIAL		SCALE 6:1	RESTRICTED TO
CUSTOMER DRAWING		SIZE A2 00779	DRAWING NO. C-1969342
		SHEET 1 OF 1	REV A