

MATERIALS		
COMPONENT NAME	BASE MATERIAL	FINISH
CASE	LCP, BLACK, UL94 V-0	
TERMINAL, WIRE LUG (GOLD)	BRASS	GOLD OVER NICKEL
TERMINAL, PC & RA (GOLD)	BRASS	GOLD OVER NICKEL IN CONTACT AREA, TIN OVER NICKEL IN SOLDER AREA
TERMINAL, VRA (GOLD)	BRASS	GOLD OVER NICKEL IN CONTACT AREA, TIN OVER NICKEL IN SOLDER AREA
TERMINAL, WIRE LUG (SILVER)	SILVER CLAD COPPER	SILVER OVER NICKEL
TERMINAL, PC (SILVER)	SILVER CLAD COPPER	SILVER OVER NICKEL
CONTACT (GOLD)	COPPER ALLOY OR BRASS	GOLD OVER NICKEL
CONTACT (SILVER)	SILVER CLAD COPPER OR COPPER	SILVER OVER NICKEL
FRAME	STEEL	TIN OVER COPPER
SPRING	MUSIC WIRE	
PLUNGER BUTTON	NYLON 6/6, BLACK, RED OR BLUE, UL94 HB (EXTENDED) OR UL94V-2 (FLUSH)	
SUPPORT BRACKET (RA*ES VERSIONS ONLY)	BRASS	TIN OVER COPPER
SUPPORT BRACKET VRA (B&C BUSHINGS ONLY)	STEEL	TIN OVER COPPER
BUSHING	BRASS	NICKLE OVER COPPER
MOUNTING NUT	BRASS	NICKEL
LOCKWASHER	STEEL	NICKEL
ES HOUSING	NYLON 6/6, NATURAL, UL94 V-2	
ES BOOT	VINYL PLASTISOL, BLACK	

PART NUMBER MATRIX									
MODEL	ACTUATOR	POLES	RATING	FUNCTION	PLATING	TERMINATIONS	PROCESS SEAL	BUTTON COLOR	04
TPC	BLANK=EXTENDED	1	1=GOLD .4VA	C=SPST MOMENTARY	G=GOLD	BLANK=WIRE LUG	ES=PROCESS SEALED	0=BLACK	
	F=FLUSH	2	3=SILVER 1 AMP	F=SPDT MOMENTARY	BLANK=SILVER	PC=PRINTED CIRCUIT		2=RED	
				M=DPST MOMENTARY		RA=RIGHT ANGLE		6=BLUE	
				R=DPDT MOMENTARY		VRA=VERTICAL RIGHT ANGLE			

NOTES:
 1. AVAILABLE WITH B & C BUSHINGS ONLY
 2. SILVER ONLY AVAILABLE IN WIRE LUG AND PC TERMINATIONS
 3. RAES AVAILABLE WITH B & C BUSHING ONLY
 4. VRA ONLY AVAILABLE IN SINGLE POLE

SPECIFICATIONS	
RATING	GOLD: .4VA MAX. @ 20VDC OR PEAK AS RESISTIVE SILVER: 1A @ 125VAC OR 28 VDC RESISTIVE
INITIAL TERMINATION RESISTANCE	20 MILLIOHMS MAX.
INSULATION RESISTANCE	1,000 MEGOHMS MIN @ 500 VDC
DIELECTRIC STRENGTH	1,000 VOLTS RMS AT SEA LEVEL
TIMING	BREAK BEFORE MAKE
PLUNGER TRAVEL	.030
ACTUATION FORCE	50 TO 400 GRAMS
LIFE EXPECTANCY	.4 VA, 1 POLE: 100,000 .4 VA, 2 POLES: 80,000 1 A, 1 POLE: 60,000 1 A, 2 POLES: 50,000
OPERATING TEMPERATURE	-30°C TO +65°C
STORAGE TEMPERATURE	-30°C TO +65°C
TERMINAL SEAL	SINGLE POLE: EPOXY DOUBLE POLE: EPOXY OPTIONAL

- NOTES:
- TERMINAL NUMBERS ARE FOR REFERENCE ONLY AND DO NOT APPEAR ON SWITCHES
 - ALL MATERIALS AND FINISHES COMPLY WITH EU DIRECTIVE 2002/95/EC OF 27JAN2003 (ROHS)
 - DISPOSABLE BOOT SUPPLIED WITH ES VERSIONS. BOOT TO BE PLACED OVER BUSHING BEFORE SOLDER WASHING
4. CENTER TERMINAL PRESENT ON DOUBLE THROW SWITCHES ONLY.

TYCO P/N	ALCO P/N	FLUSH ACTUATOR	POLES	THROWS	PLATING	TERMINALS	PROCESS SEALED	BUTTON COLOR	FUNCTION				CONNECTED TERMINALS		DIM A
									OFF	MOM	ON	MOM	1-3	2-3	
1825098-1	TPC11CGPC004	NO	1	1	GOLD	PC	NO	BLACK	OFF	MOM	OFF	OFF	1-3	.133	
1825098-2	TPC11CGRA004	NO	1	1	GOLD	RIGHT ANGLE	NO	BLACK	OFF	MOM	OFF	OFF	1-3	.133	
1825098-3	TPC11CGRA204	NO	1	1	GOLD	RIGHT ANGLE	NO	RED	OFF	MOM	OFF	OFF	1-3	.133	
1825098-4	TPC11CGVRA004	NO	1	1	GOLD	VRA	NO	BLACK	OFF	MOM	OFF	OFF	1-3	N/A	
1825098-5	TPC11FGPC004	NO	1	2	GOLD	PC	NO	BLACK	ON	MOM	1-2	2-3	.133		
1825098-6	TPC11FGRA004	NO	1	2	GOLD	RIGHT ANGLE	NO	BLACK	ON	MOM	1-2	2-3	.133		
1825098-7	TPC11FGVRA004	NO	1	2	GOLD	VRA	NO	BLACK	ON	MOM	1-2	2-3	N/A		
1825098-8	TPC11FGVRA204	NO	1	2	GOLD	VRA	NO	RED	ON	MOM	1-2	2-3	N/A		
1825098-9	TPC13C004	NO	1	1	SILVER	WIRE LUG	NO	BLACK	OFF	MOM	OFF	OFF	1-3	.133	
1-1825098-0	TPC13C204	NO	1	1	SILVER	WIRE LUG	NO	RED	OFF	MOM	OFF	OFF	1-3	.133	
1-1825098-1	TPC13CPC004	NO	1	1	SILVER	PC	NO	BLACK	OFF	MOM	OFF	OFF	1-3	.133	
1-1825098-2	TPC13F004	NO	1	2	SILVER	WIRE LUG	NO	BLACK	ON	MOM	1-2	2-3	.133		
1-1825098-3	TPC21MGRA204	NO	2	1	GOLD	RIGHT ANGLE	NO	RED	OFF	MOM	OFF	OFF	1-3, 4-6	N/A	
1-1825098-4	TPC21RGPC004	NO	2	2	GOLD	PC	NO	BLACK	ON	MOM	1-2, 4-5	2-3, 5-6	N/A		
1-1825098-5	TPC23M004	NO	2	1	SILVER	WIRE LUG	NO	BLACK	OFF	MOM	OFF	OFF	1-3, 4-6	N/A	
1-1825098-6	TPC23R204	NO	2	2	SILVER	WIRE LUG	NO	RED	ON	MOM	1-2, 4-5	2-3, 5-6	N/A		
1-1825098-7	TPCF11CGPC004	YES	1	1	GOLD	PC	NO	BLACK	OFF	MOM	OFF	OFF	1-3	.000	
1-1825098-8	TPCF11CGRA004	YES	1	1	GOLD	RIGHT ANGLE	NO	BLACK	OFF	MOM	OFF	OFF	1-3	.000	
1-1825098-9	TPCF11FGRA004	YES	1	2	GOLD	RIGHT ANGLE	NO	BLACK	ON	MOM	1-2	2-3	.000		
2-1825098-0	TPCF13C004	YES	1	1	SILVER	WIRE LUG	NO	BLACK	OFF	MOM	OFF	OFF	1-3	.000	
2-1825098-1	TPCF13C004	YES	1	2	SILVER	WIRE LUG	NO	BLACK	ON	MOM	1-2	2-3	.000		

THIS DRAWING IS A CONTROLLED DOCUMENT. DWN FRAGHU 12-5-05

TYCO Electronics Tyco Electronics Corporation Harrisburg, Pa 17105-3608

PRODUCT SPEC: PUSHBUTTON SWITCH, TPC SERIES

SIZE: A1 CAGE CODE: 00779 DRAWING NO: 1825098

CUSTOMER DRAWING SCALE: 4:1 SHEET: 1 OF 5 REV: A

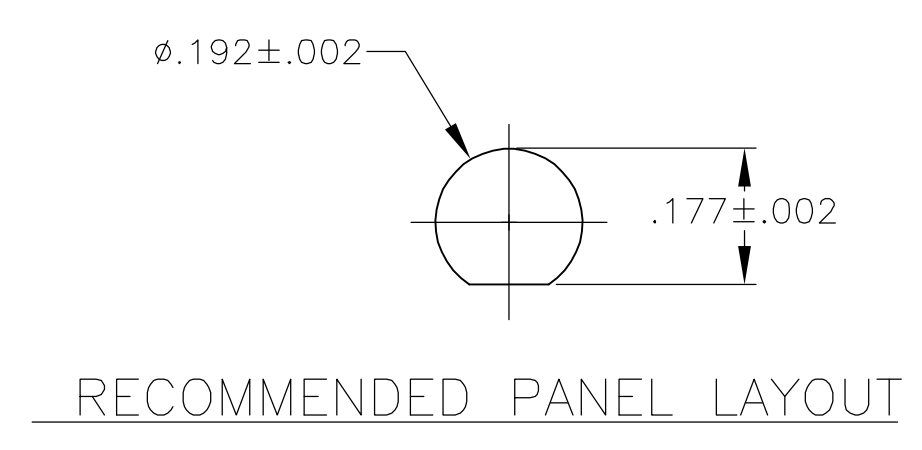
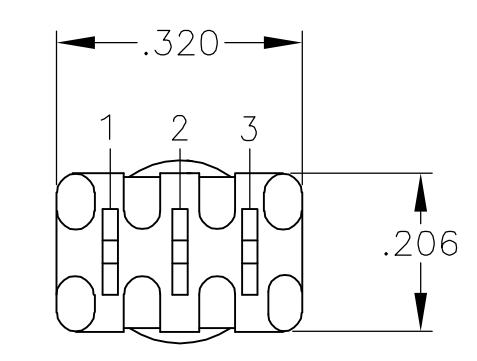
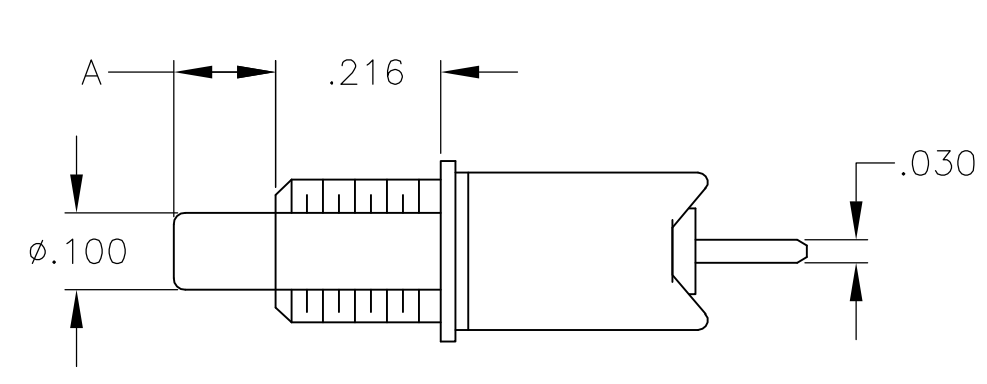
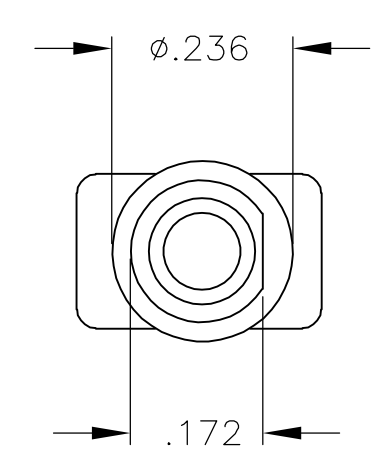
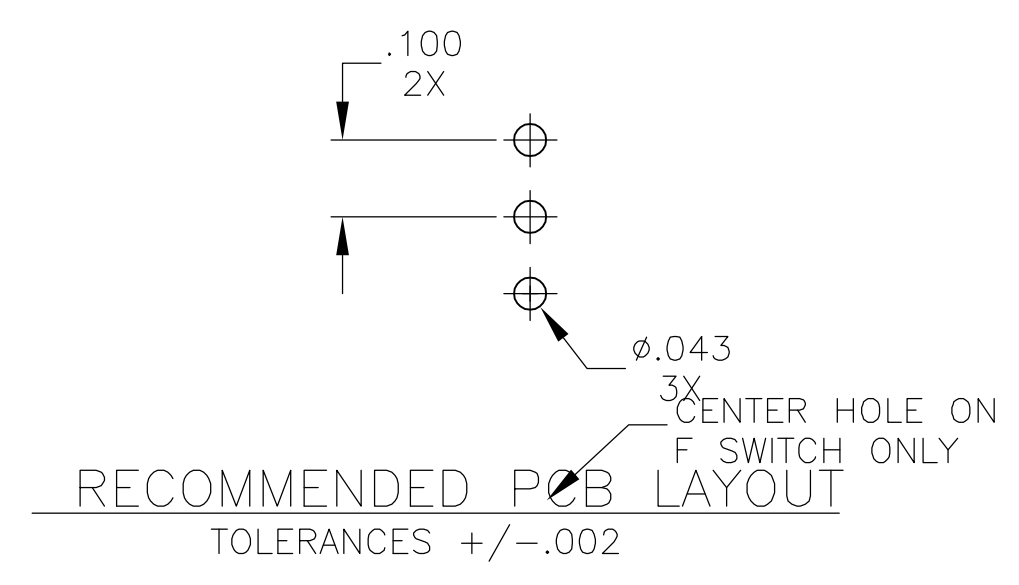
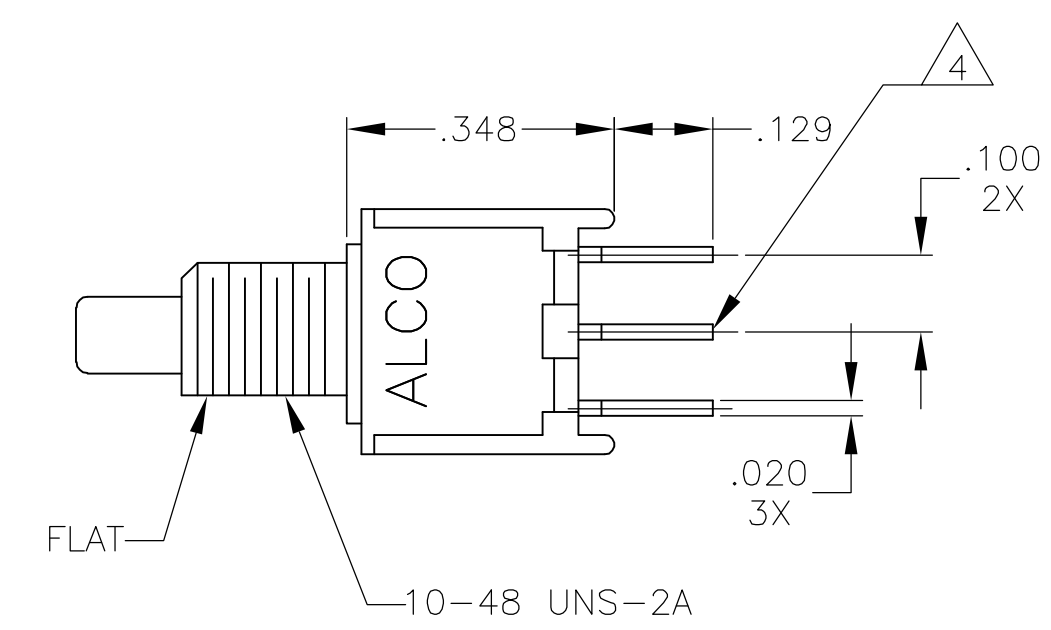

TPC11CGPC, TPC11FGPC
 TPCF11CGPC, TPC13CPC

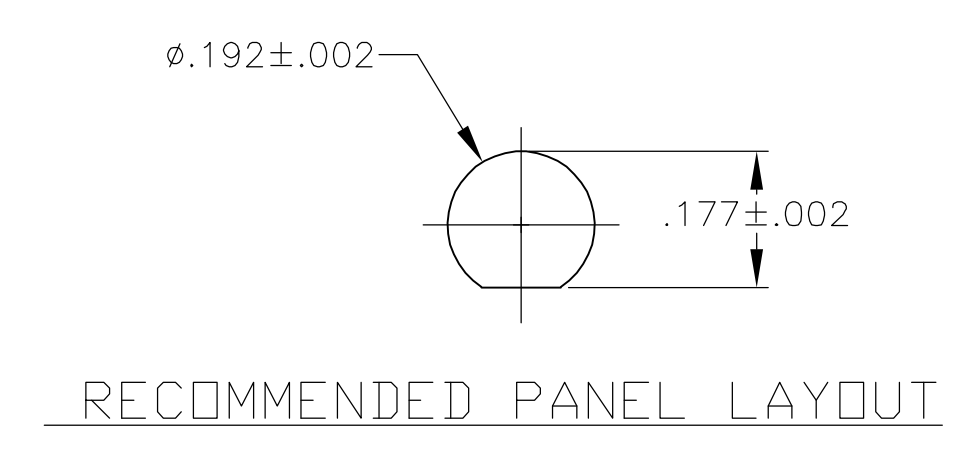
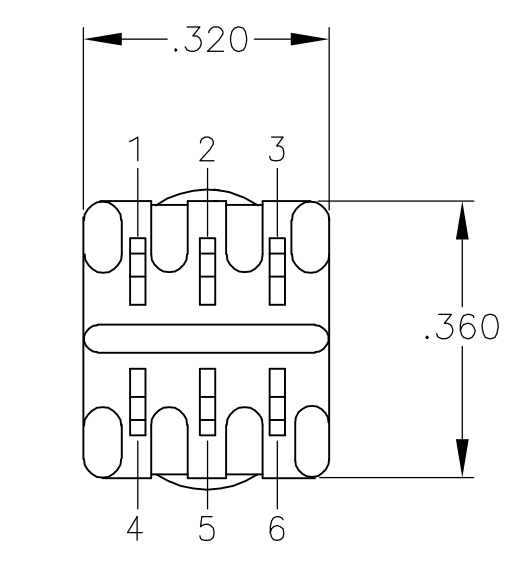
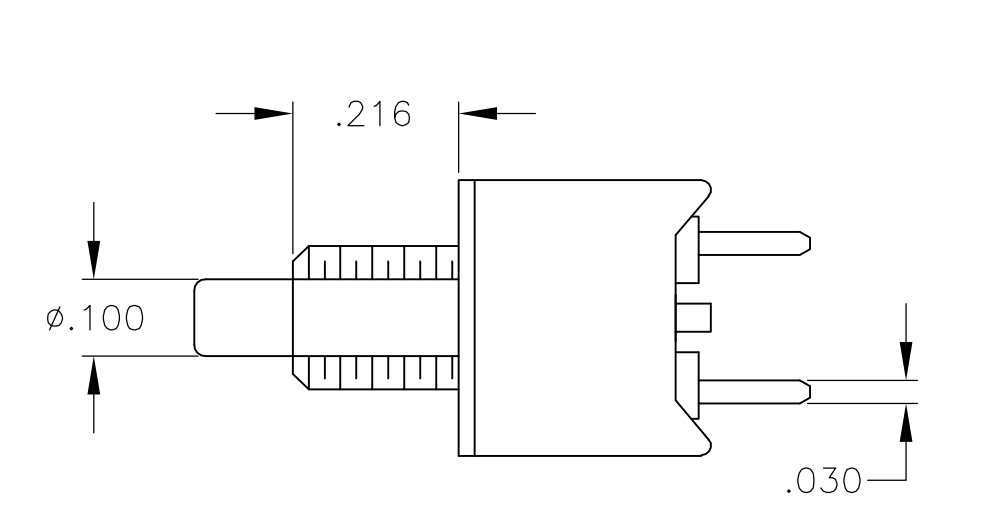
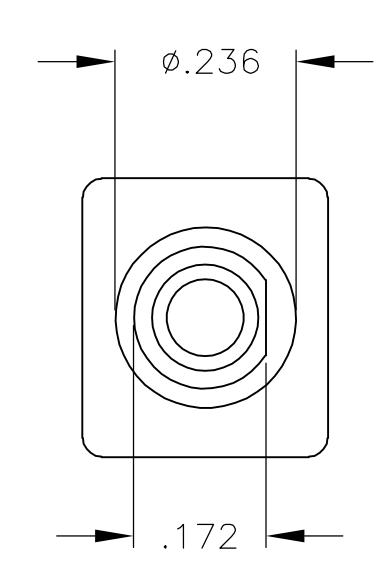
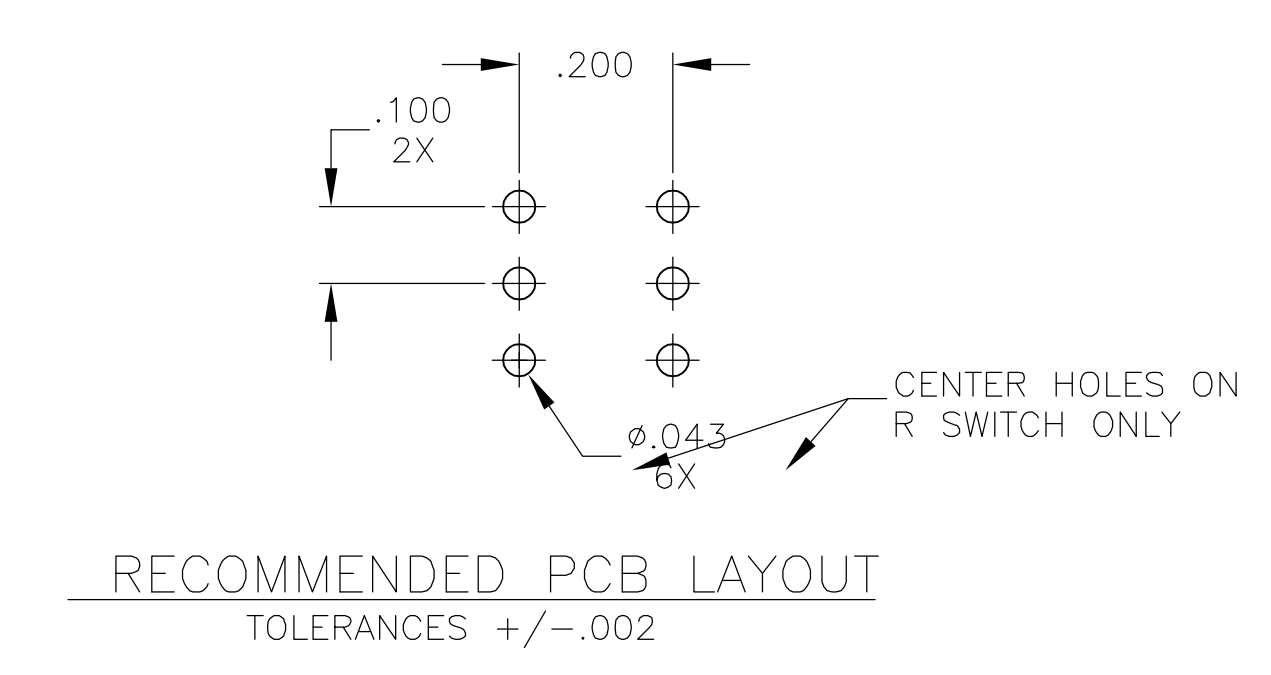
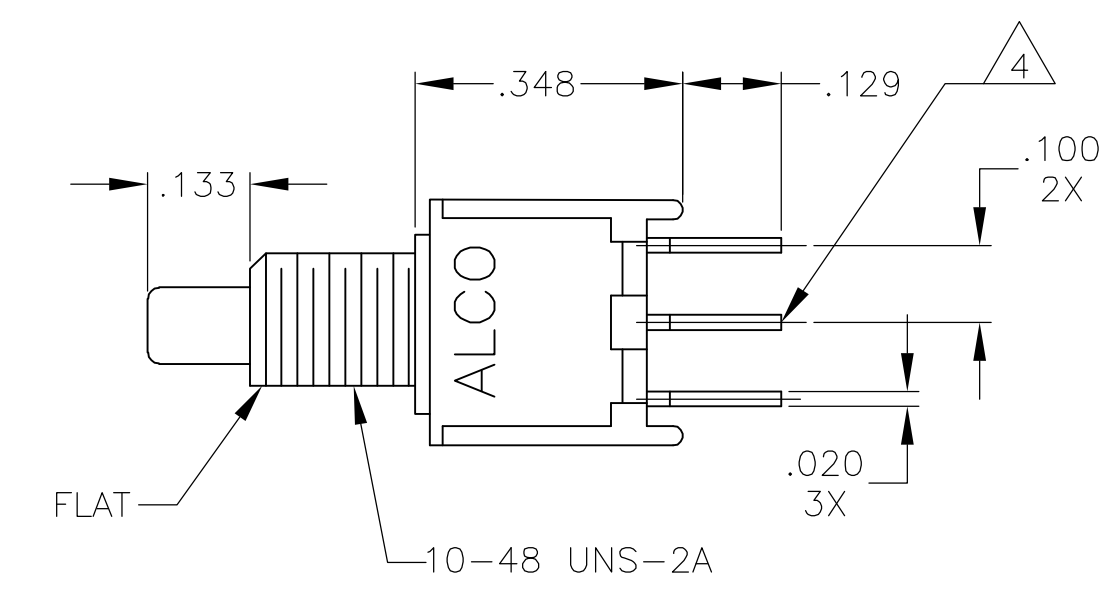

TPC21RGPC

THIS DRAWING IS A CONTROLLED DOCUMENT.		DWN RAGHU 12-5-05		Tyco Electronics Corporation Harrisburg, Pa 17105-3608
DIMENSIONS: INCHES		CHK -		NAME
TOLERANCES UNLESS OTHERWISE SPECIFIED:		APVD -	PRODUCT SPEC	-
0 PLC ± -		APPLICATION SPEC	SIZE	A1
1 PLC ± -		WEIGHT	CAGE CODE	00779
2 PLC ± -		CUSTOMER DRAWING	DRAWING NO	1825098
3 PLC ± .010		SCALE	RESTRICTED TO	-
4 PLC ± -		4:1	SHEET	2 OF 5
ANGLES ± °		REV		A

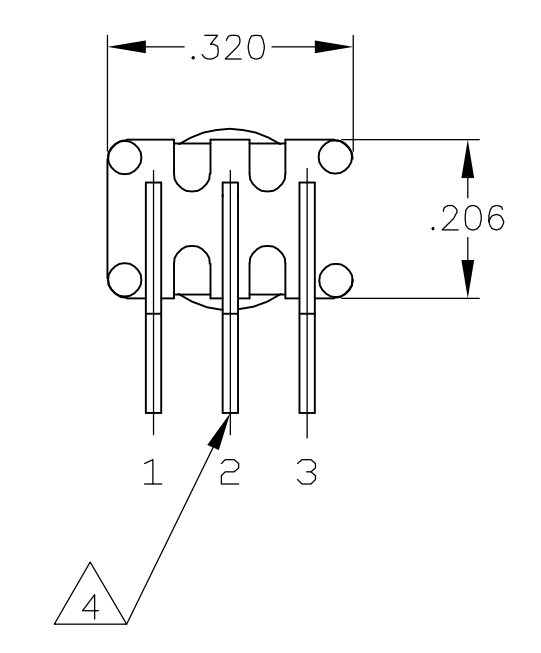
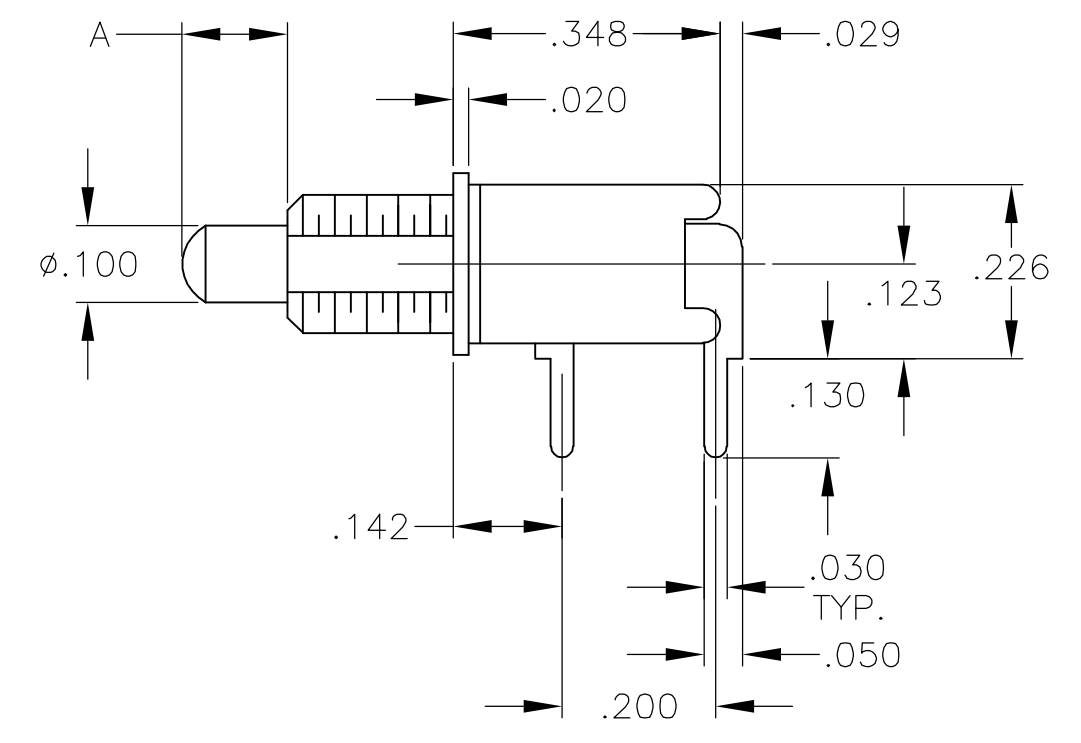
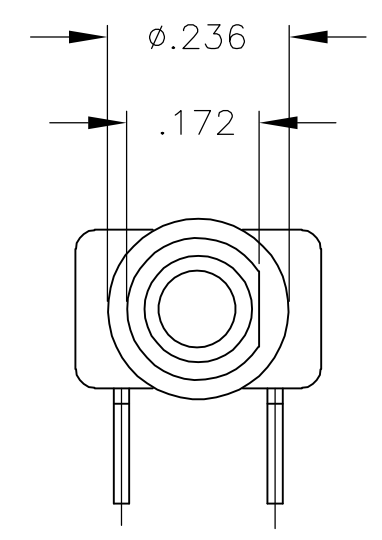
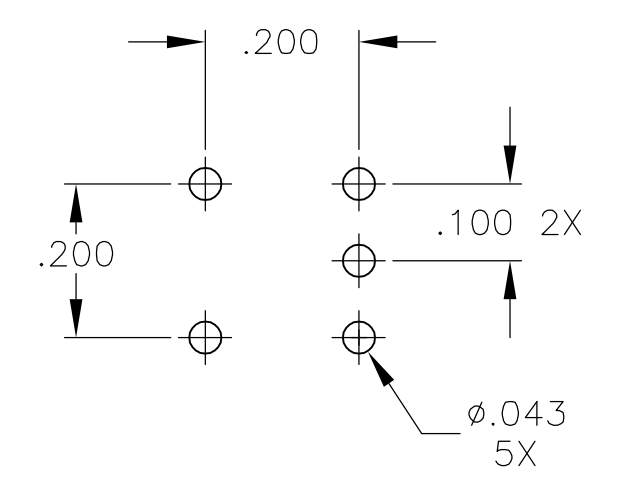
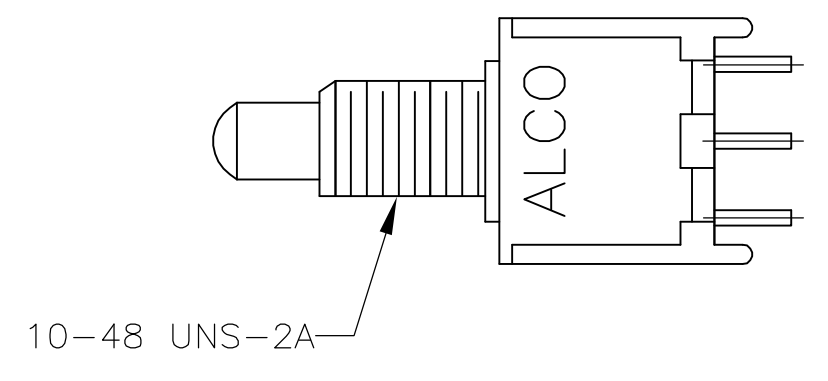

RECOMMENDED PCB LAYOUT
 TOLERANCES +/- .002

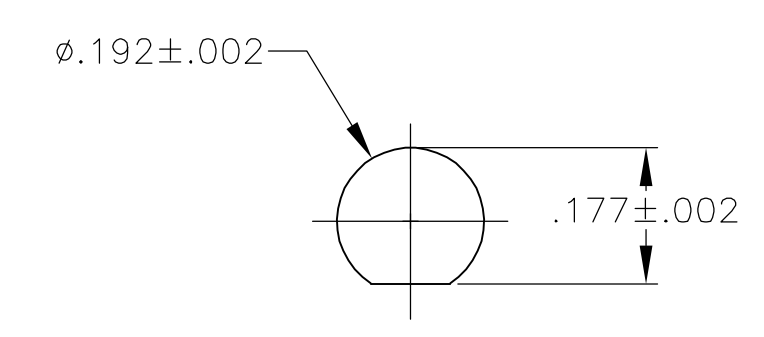

RECOMMENDED PANEL LAYOUT

TPC11CGRA, TPC11FGRA
 TPCF11CGRA, TPCF11FGRA

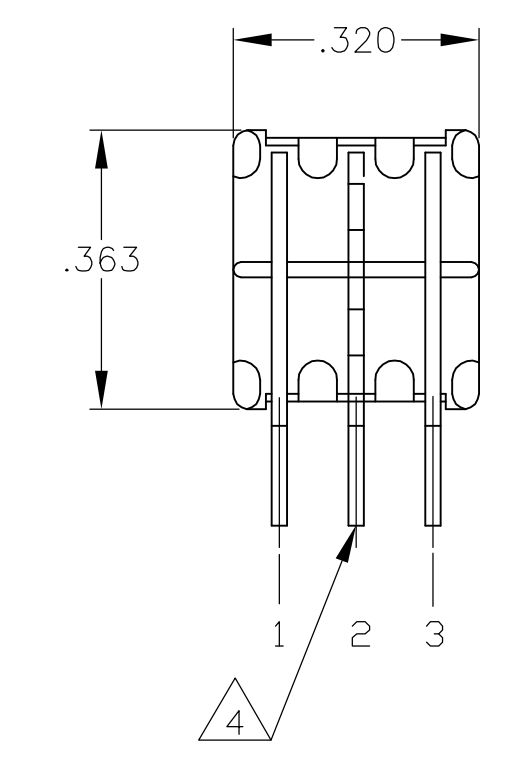
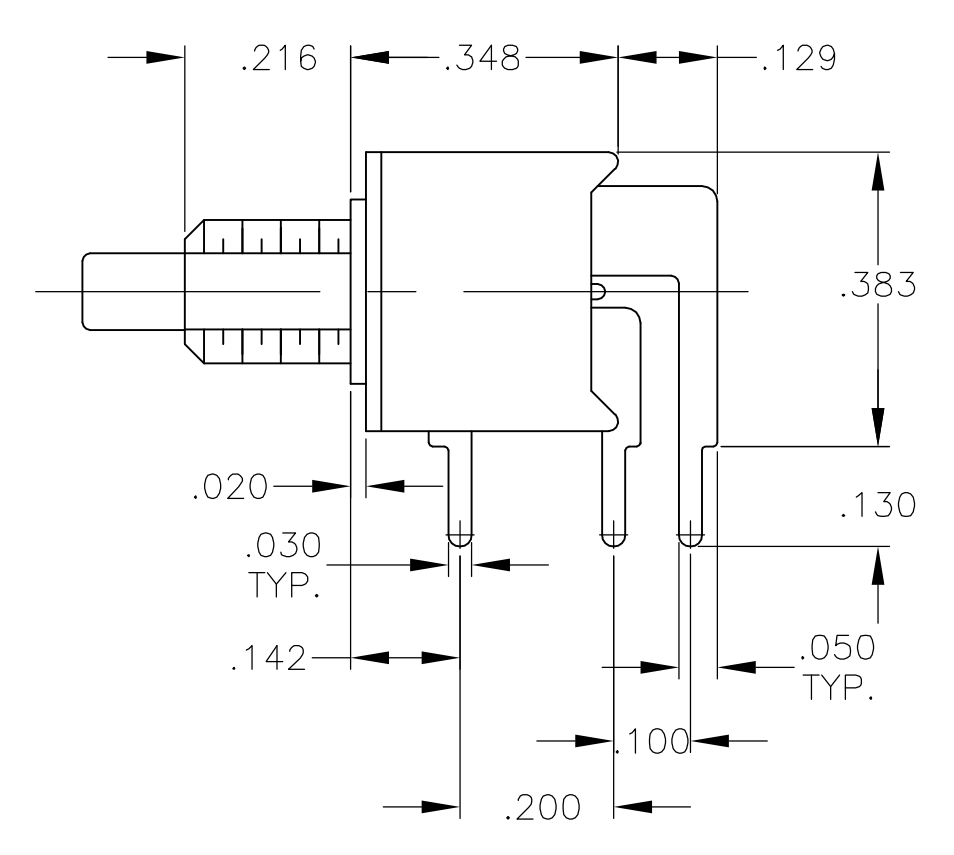
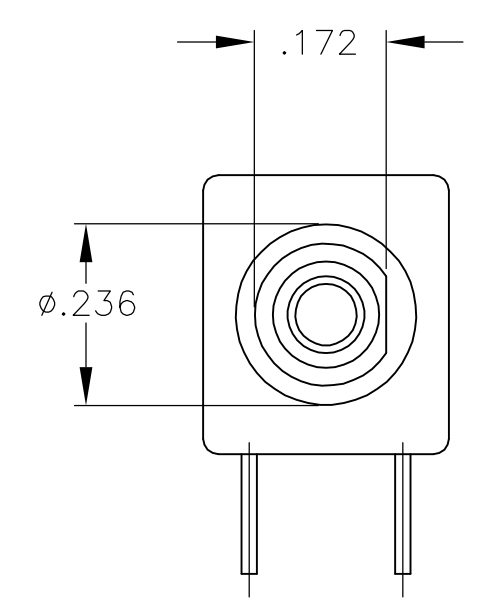
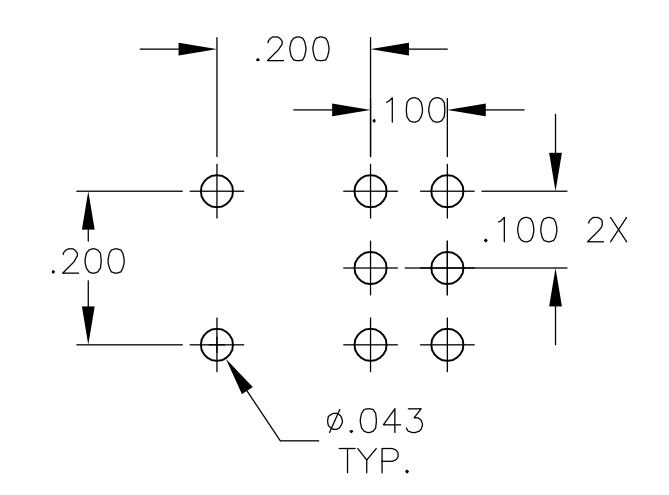
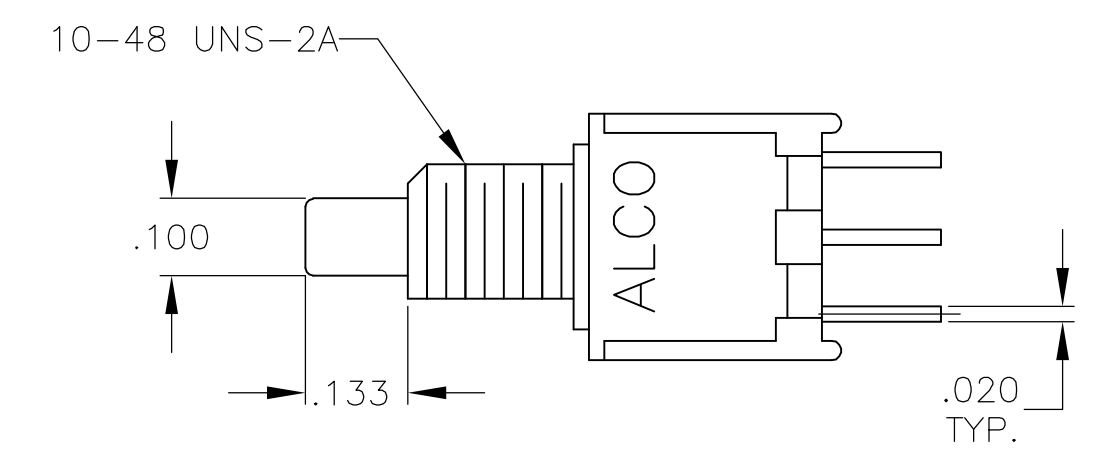

RECOMMENDED PCB LAYOUT
 TOLERANCES +/- .002

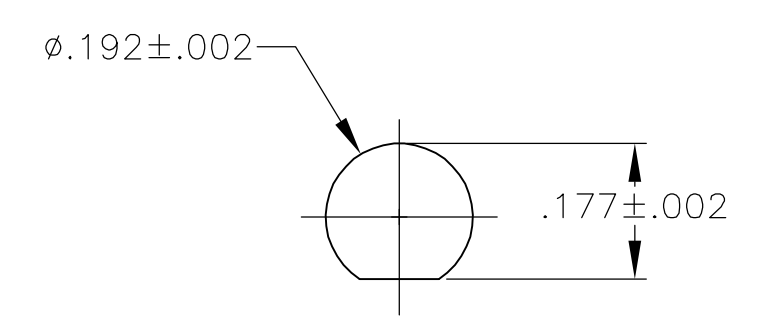

RECOMMENDED PANEL LAYOUT

TPC21MGRA

THIS DRAWING IS A CONTROLLED DOCUMENT.		DWN RAGHU	12-5-05		Tyco Electronics Corporation Harrisburg, Pa 17105-3608
DIMENSIONS: INCHES		CHK ---	APVD ---		NAME PRODUCT SPEC
TOLERANCES UNLESS OTHERWISE SPECIFIED:		0 PLC ± -		APPLICATION SPEC	RESTRICTED TO
1 PLC ± -		2 PLC ± -		SIZE	A1
3 PLC ± .010		4 PLC ± -		CAGE CODE	1825098
ANGLES ± ± °		FINISH		DRAWING NO	100779
MATERIAL		WEIGHT		SCALE	4:1
		CUSTOMER DRAWING		SHEET	3 OF 5
				REV	A

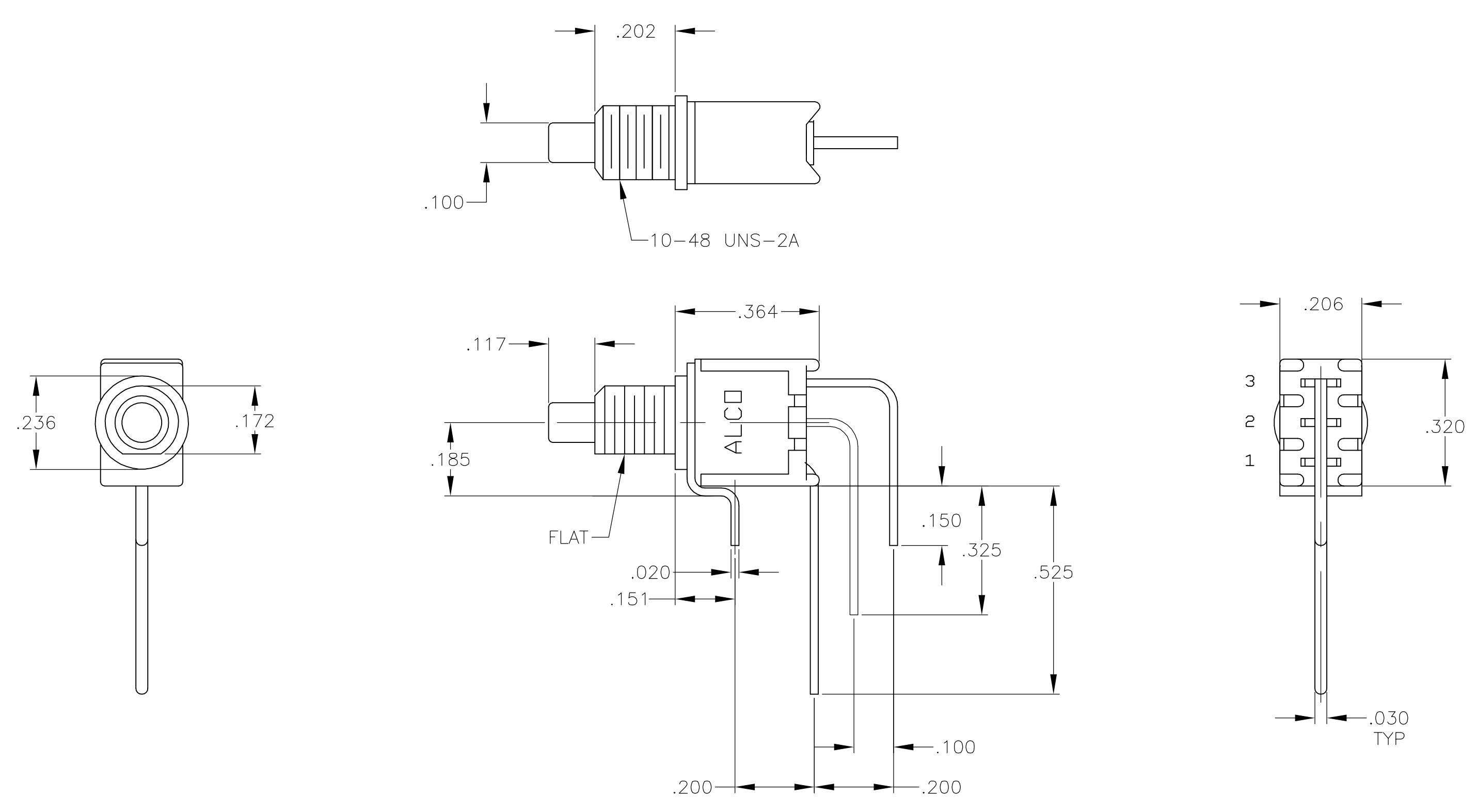

TPC11CGVRA, TPC11FGVRA

RECOMMENDED PCB LAYOUT
 TOLERANCES +/- .002

RECOMMENDED PANEL LAYOUT

THIS DRAWING IS A CONTROLLED DOCUMENT.		DWG	12-5-05	Tyco Electronics Corporation	
DIMENSIONS: INCHES		CHK	RAGHU	Harrisburg, Pa 17105-3608	
TOLERANCES UNLESS OTHERWISE SPECIFIED:		APVD		PUSHBUTTON SWITCH, TPC SERIES	
0 PLC	± .005	PRODUCT SPEC		-	
1 PLC	± .005	APPLICATION SPEC		-	
2 PLC	± .005	WEIGHT		-	
3 PLC	± .010	CUSTOMER DRAWING		-	
4 PLC	± .010	SCALE	4:1	SHEET	4 OF 5
ANGLES	± .5°	RESTRICTED TO		-	
MATERIAL		SIZE	A1	CAGE CODE	00779
FINISH		DRAWING NO	1825098	REV	

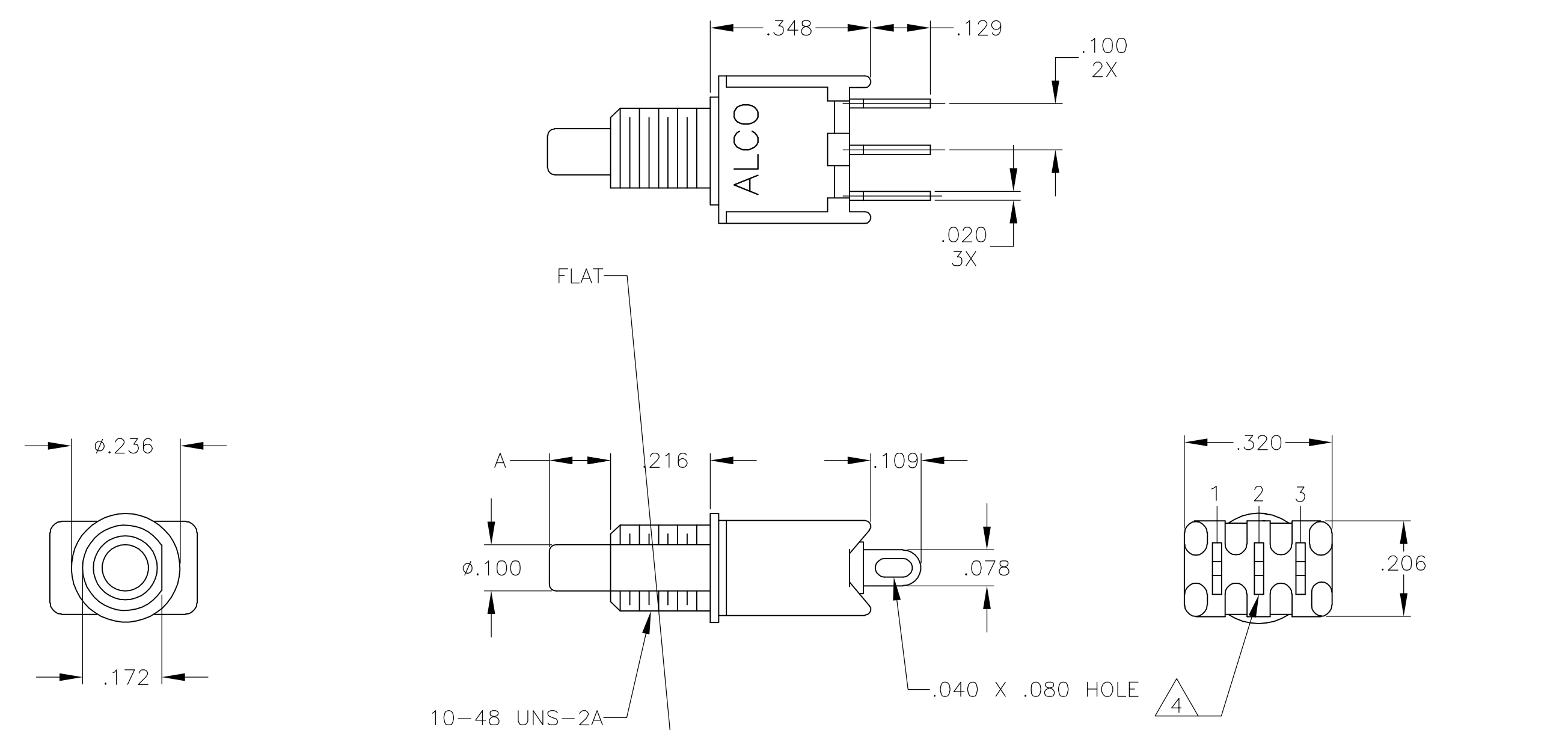

TPC13C, TPC13F,
TPCF13C, TPC13F

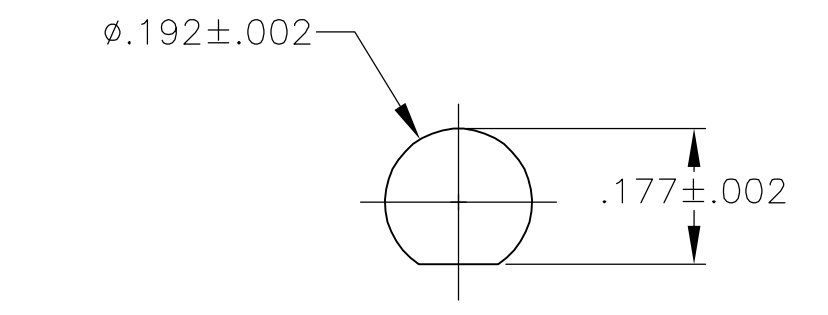

RECOMMENDED PANEL LAYOUT

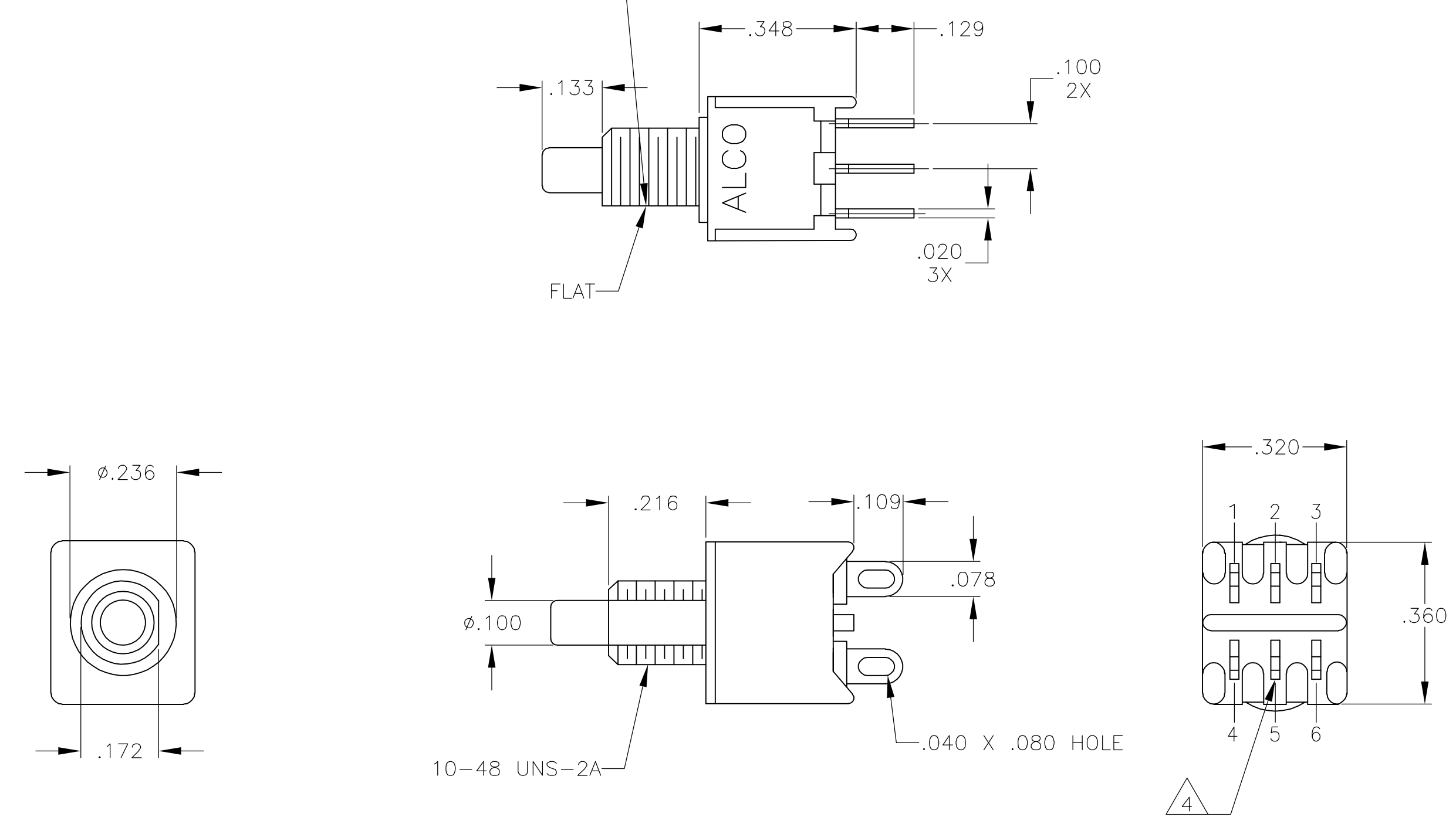

TPC23M, TPC23R

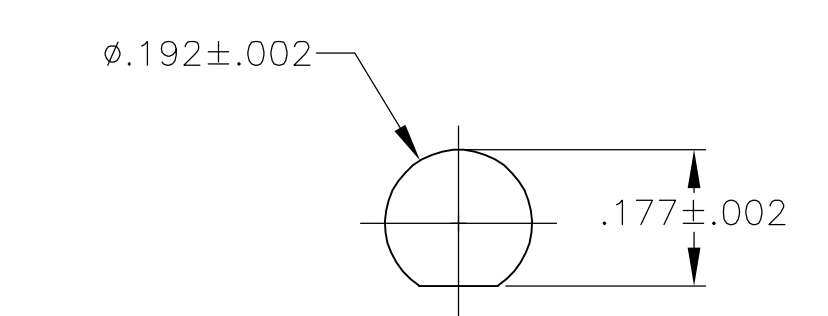

RECOMMENDED PANEL LAYOUT

THIS DRAWING IS A CONTROLLED DOCUMENT.		DWN	12-5-05	tyco Electronics	Tyco Electronics Corporation Harrisburg, Pa 17105-3608
		CHK	RAGHU		
DIMENSIONS:	TOLERANCES UNLESS OTHERWISE SPECIFIED:	APVD		PRODUCT SPEC	PUSHBUTTON SWITCH, TPC SERIES
INCHES				APPLICATION SPEC	
0 PLC ± .010	1 PLC ± .010			SIZE	A1
2 PLC ± .010	3 PLC ± .010			SCALE	4:1
4 PLC ± .010	ANGLES ± .5°			DRAWING NO	1825098
MATERIAL	FINISH	WEIGHT		RESTRICTED TO	
				CUSTOMER DRAWING	SHEET 5 OF 5
					REV A