

NUMBER  
C-1775027

3RD ANGLE PROJECTION

METRIC

THIS INFORMATION IS CONFIDENTIAL AND IS DISCLOSED TO YOU ON CONDITION THAT NO FURTHER DISCLOSURE IS MADE BY YOU TO OTHER THAN AMP PERSONNEL WITHOUT WRITTEN AUTHORIZATION FROM AMP (TAIWAN) LTD.

PRINT DIST  
DW

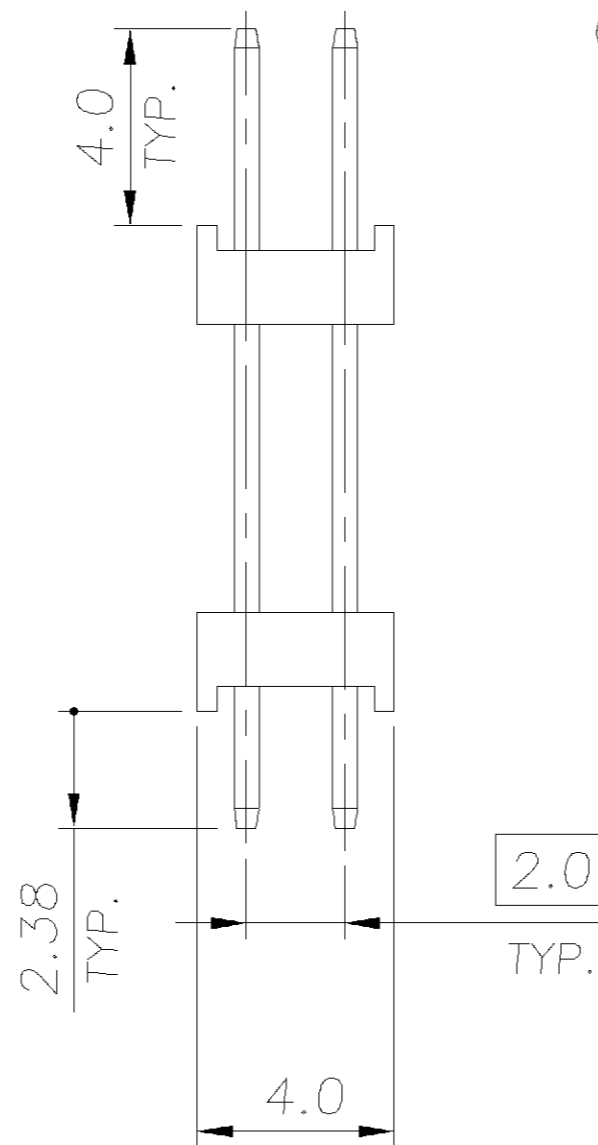
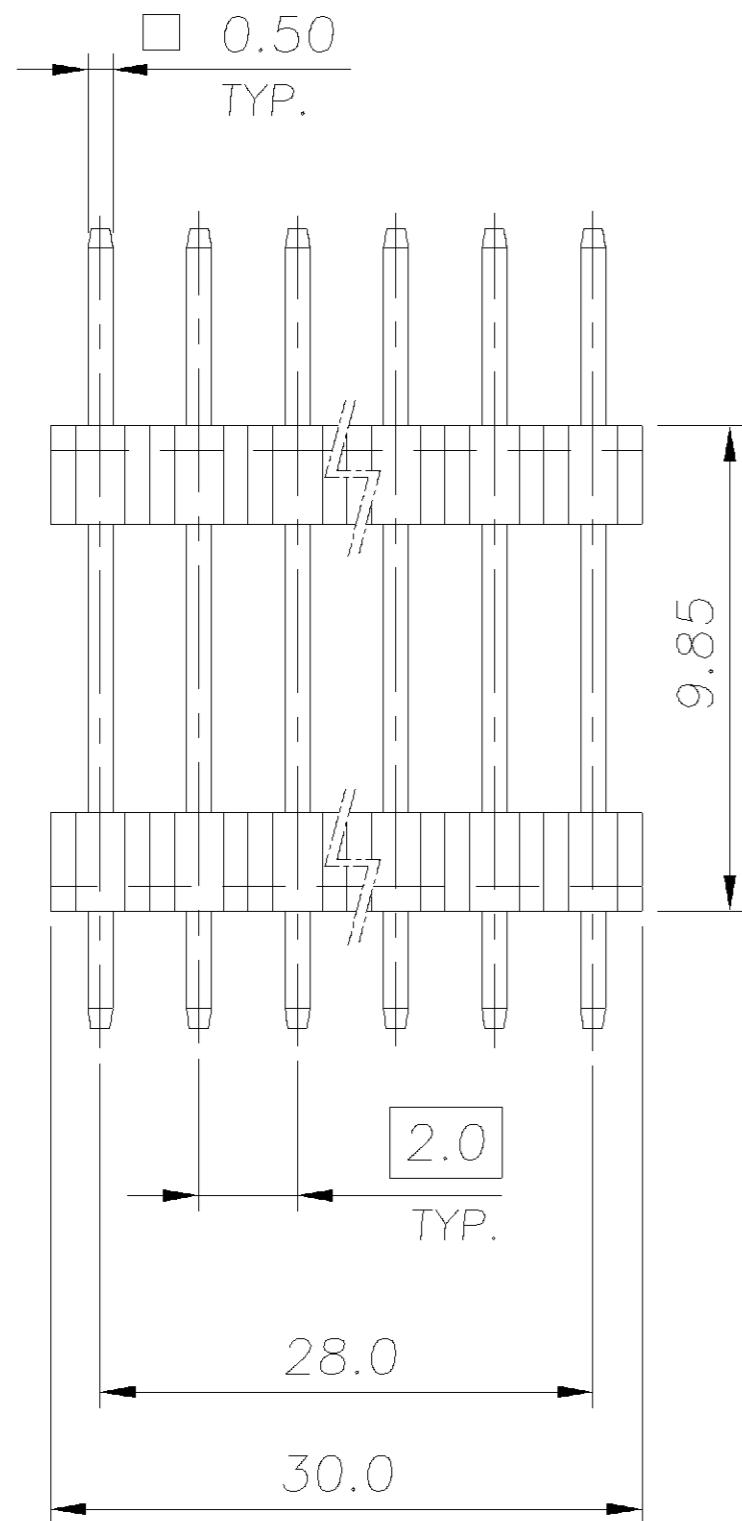

NOTES:

- MATERIAL:  
HOUSING : THERMOPLASTIC, UL94V-0, BLACK COLOR  
CONTACTS : BRASS
- FINISH :  
CONTACT : GOLD FLASH PLATED  
50 μ" MIN. NICKEL UNDERPLATED OVERALL

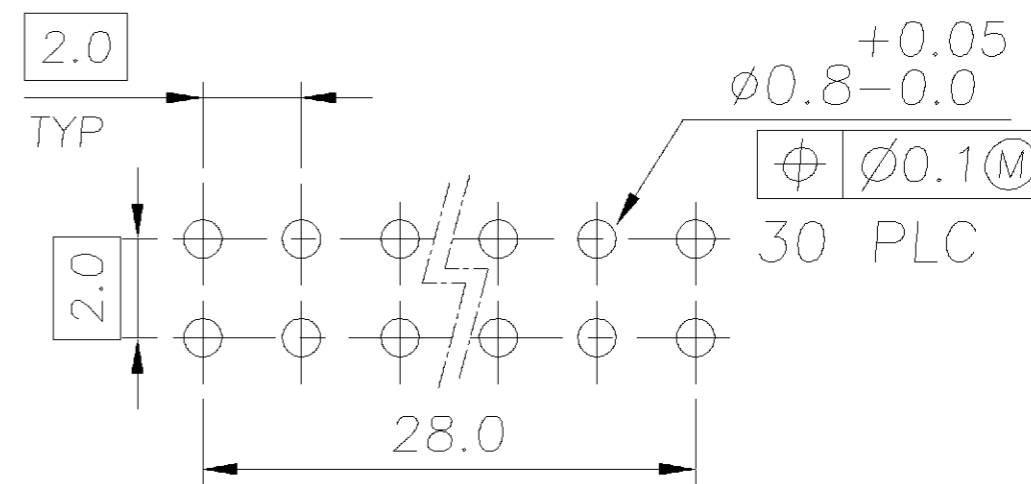

RECOMMENDED P.C. BOARD LAYOUT

30	1775027-1
No. OF CONTACT	PART NUMBER

TOLERANCES UNLESS OTHERWISE SPECIFIED: 0 PLC ± 1 PLC ±0.3 2 PLC ±0.2 3 PLC ± ANGLES ± 3'		DWN J. LEE 18-AUG-2004	<b>tyco</b> <b>Electronics</b> TYCO HOLDINGS (BERMUDA) VII LTD. TAIWAN BRANCH
MATERIAL SEE NOTE		CHK S. HOU 18-AUG-2004	
FINISH SEE NOTE		APVD W.J. KE 18-AUG-2004	NAME STACKED HEADER, 2.0MM, V/A, DUAL ROW
		PRODUCT SPEC 108-57331	LOC DW
		QUALIFICATION TEST REPORT 501-57379	SIZE A <sub>3</sub>
		WEIGHT	DRAWING NO C-1775027
			REV 0
			SCALE --
			SHEET 1 OF 1

0	FIRST RELEASED	FZ00-0149-04	JL	18AUG 2004
LTR	REVISION RECORD	ECN	DWN CHK	DATE

8

7

6

5

4

3

2

1

CUSTOMER DRAWING

D

C

B

A

THIS INFORMATION IS CONFIDENTIAL AND IS DISCLOSED TO YOU ON CONDITION THAT NO FURTHER DISCLOSURE IS MADE BY YOU TO OTHER THAN AMP PERSONNEL WITHOUT WRITTEN AUTHORIZATION FROM AMP (TAIWAN) LTD. DIMENSIONS IN MILLIMETERS. DO NOT SCALE PRINT.

PRINT DIST  
DW

METRIC

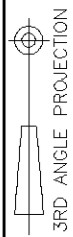

NUMBER  
C-1775027

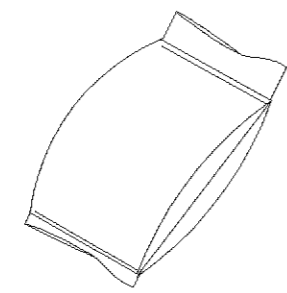

BAG X20

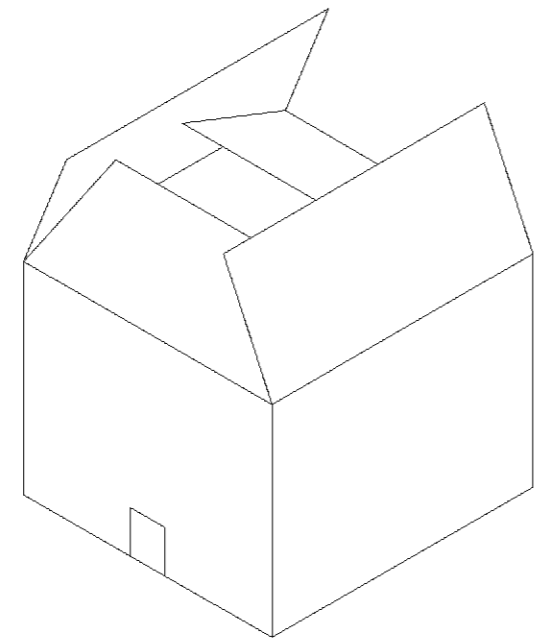

NOTES:  
 1.DIMENSION:  
     BAG :L=200mm,W=150mm  
     SHIPPING BOX:L=370mm,W=280mm,H=320mm  
 2.QUANTITY:  
     500 PCS/BAG  
     20 BAGS/SHIPPING BOX  
 2.WEIGHT:  
     NET WEIGHT 14.5 KG/ SHIPPING BOX  
     GROSS WEIGHT 15.5 KG/SHIPPING BOX

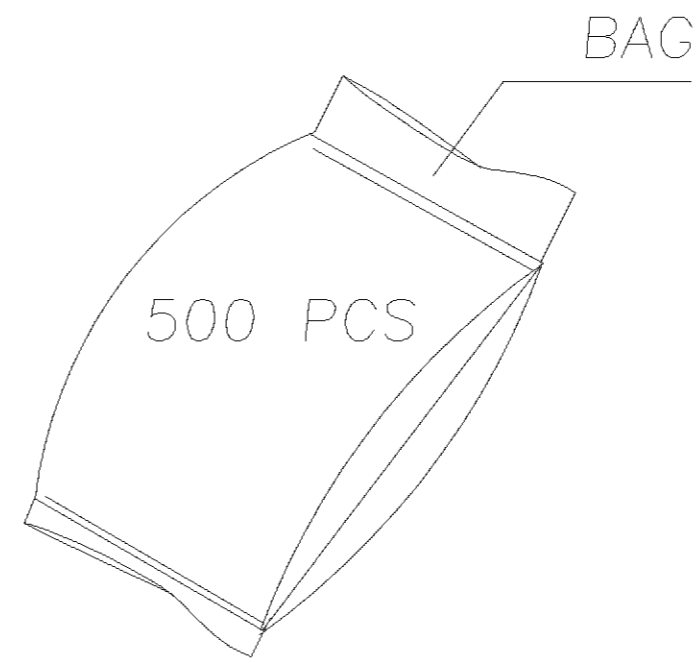

	SEE SHEET 1			
LTR	REVISION RECORD	ECN	DWN CHK	DATE

TOLERANCES UNLESS OTHERWISE SPECIFIED: 0 PLC ± 1 PLC ±0.3 2 PLC ±0.2 3 PLC ± ANGLES ± 3'		DWN J. LEE 18-AUG-2004	TYCO HOLDINGS (BERMUDA) VII LTD. TAIWAN BRANCH	
MATERIAL  SEE NOTE		CHK S. HOU 18-AUG-2004		
FINISH  SEE NOTE		APVD W.J. KE 18-AUG-2004	NAME  STACKED HEADER, 2.0MM, V/A, DUAL ROW	
		PRODUCT SPEC -	LOC DW	SIZE A <sub>3</sub>
		QUALIFICATION TEST REPORT -	DRAWING NO C-1775027	REV 0
		APPLICATION SPEC WEIGHT	SCALE --	SHEET 2 OF 2

D  
C  
B  
A