

LOC DW DIST

P		LTR	DESCRIPTION	DATE	DWN	APVD
B			REVISED. (ECR-09-016439)	13JUL09	FY	WK

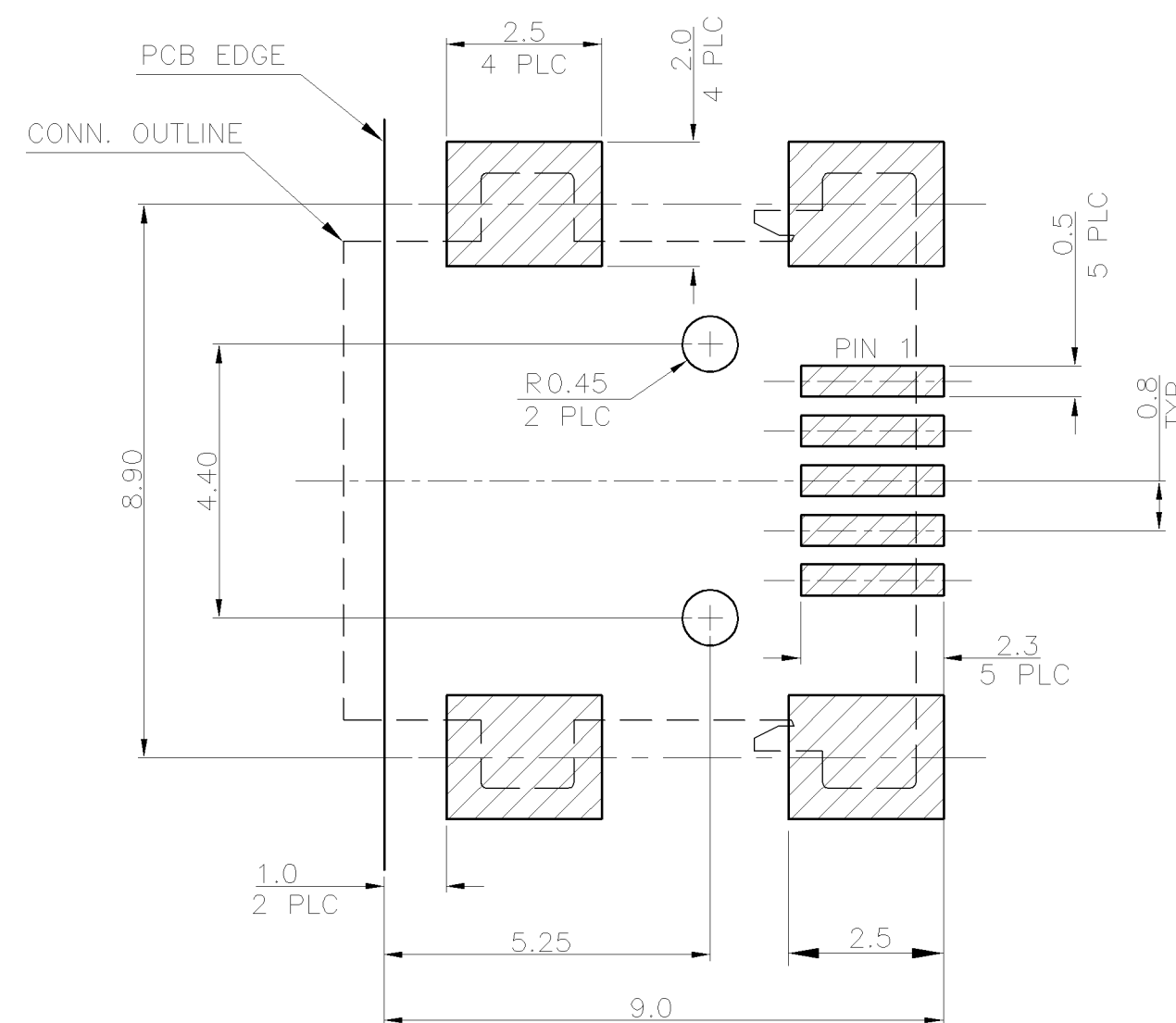

RECOMMENDED PCB LAYOUT (MOUNTING SIDE). (THICKNESS=1.6mm) (TOLERANCE=±0.05MM)

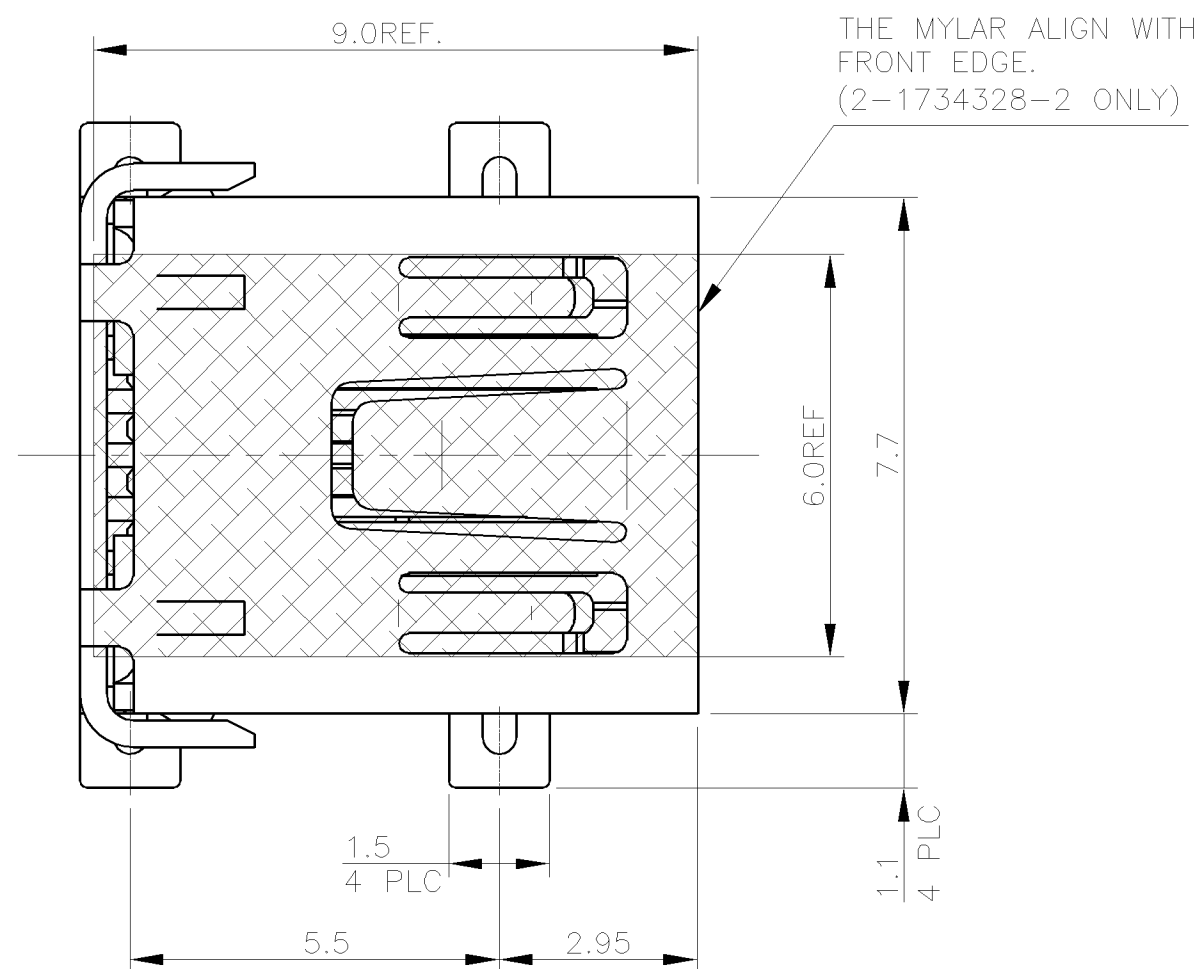
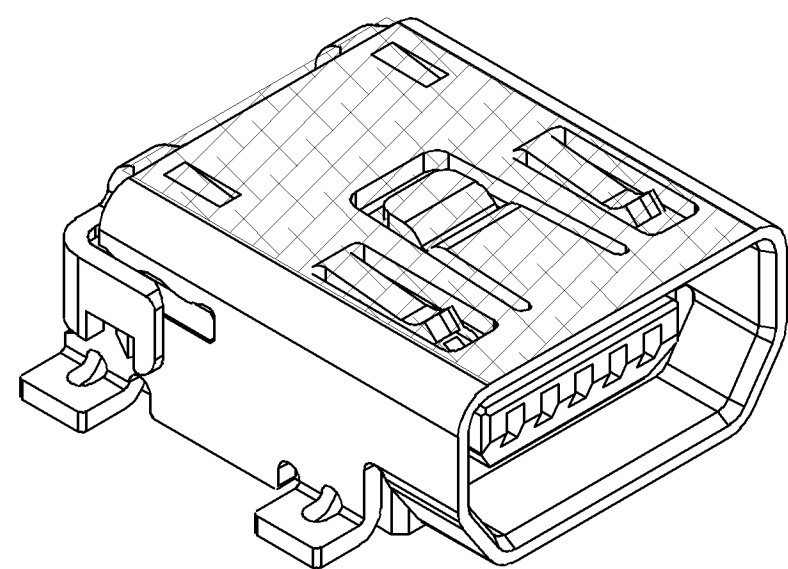
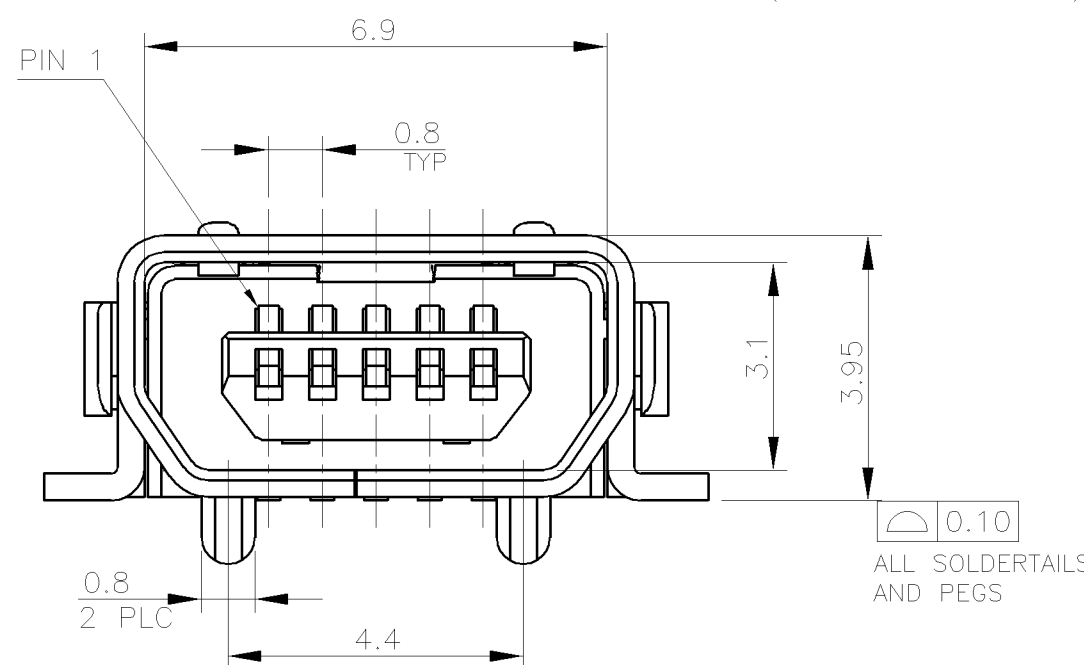
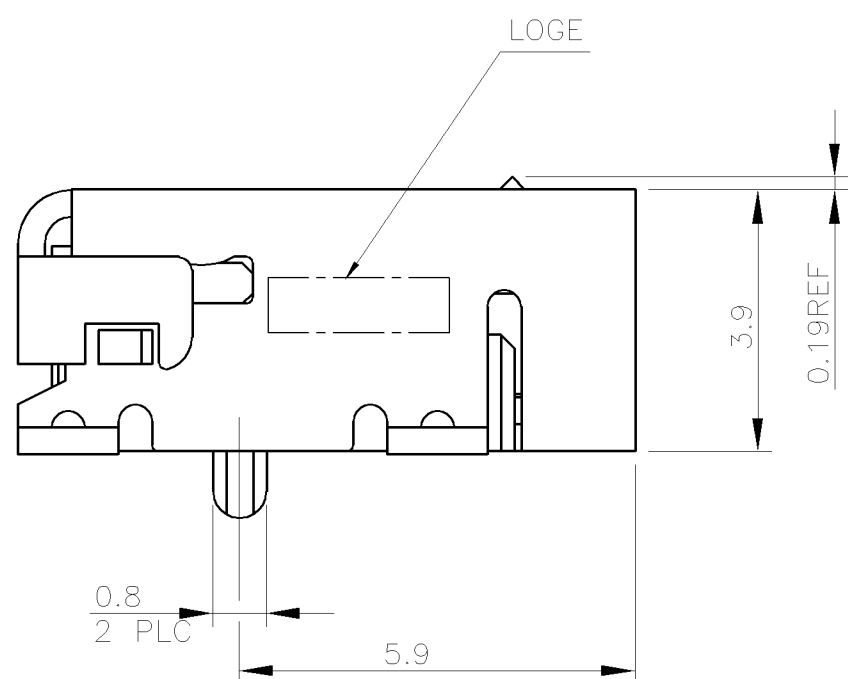
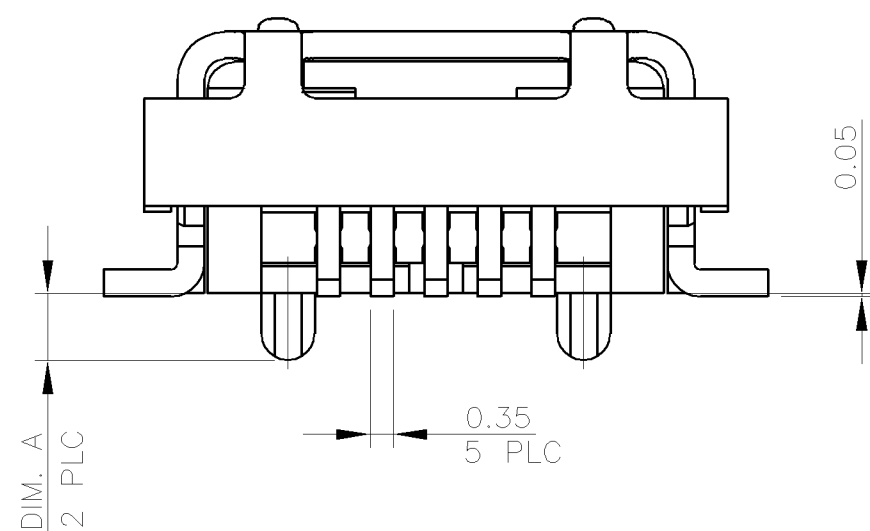

W/O	W/O	W/O	W/O	W/O	MYLAR	DIM.A	PACKAGE	PART NUMBER
1.0	0.6	0.6	1.0	1.0			REEL	2-1734328-2
							REEL	1-1734328-2
							TRAY	1-1734328-1
							REEL	1734328-2
							TRAY	1734328-1

- NOTE:
- MATERIAL:
HOUSING: PA6T W/ 30% GF, UL 94V-0, COLOR:BLACK.
CONTACT: PHOSPHOR BRONZE, THICKNESS:0.25±0.05mm.
SHELL: PHOSPHOR BRONZE, THICKNESS:0.40±0.05mm.
MYLAR: POLYESTER FILM.
 - FINISH:
CONTACTS: 0.762um [30u"] MIN GOLD PLATED ON CONTACT AREA,
2.54um [100u"] MIN TIN-CU PLATED ON SOLDER TAILS,
1.27um [50u"] MIN. NICKEL UNDERPLATED ALL OVER.
SHELL : 2.032um [80u"] MIN. NICKEL PLATED ALL OVER.
 - REFLOW SOLDER CAPABLE TO 260°C PER TE SPEC 109-201 CONDITION B.

THIS DRAWING IS A CONTROLLED DOCUMENT.		DWN F. YANG 13JUL2009	Tyco Electronics Corporation Taipei, Taiwan	
		CHK S. CHIEN 13JUL2009		
		APVD W. KODAMA 13JUL2009	NAME	
DIMENSIONS: MM		PRODUCT SPEC		MINI USB CONNECTOR, TYPE AB, RCPT, R/A, SMT TYPE
		APPLICATION SPEC		
TOLERANCES UNLESS OTHERWISE SPECIFIED:		108-57062		SIZE
0 PLC ± -		WEIGHT 0.76 GRAMS		CAGE CODE
1 PLC ± 0.3		CUSTOMER DRAWING		DRAWING NO
2 PLC ± 0.2		SCALE -		RESTRICTED TO
3 PLC ± 0.15		SHEET 1 OF 3		REV B
4 PLC ± -				
ANGLES ± 3°				
FINISH				
SEE NOTE				

LOC DW DIST

REVISIONS				
P	LTR	DESCRIPTION	DATE	APVD
		SEE SHEET 1.		

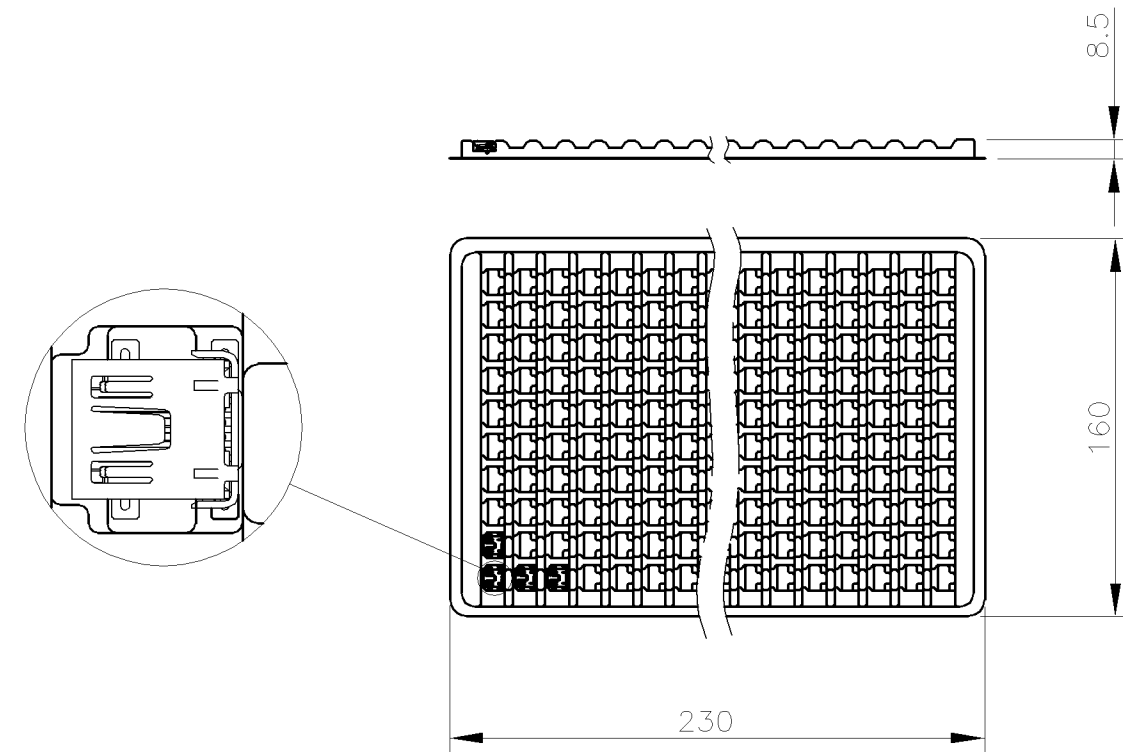
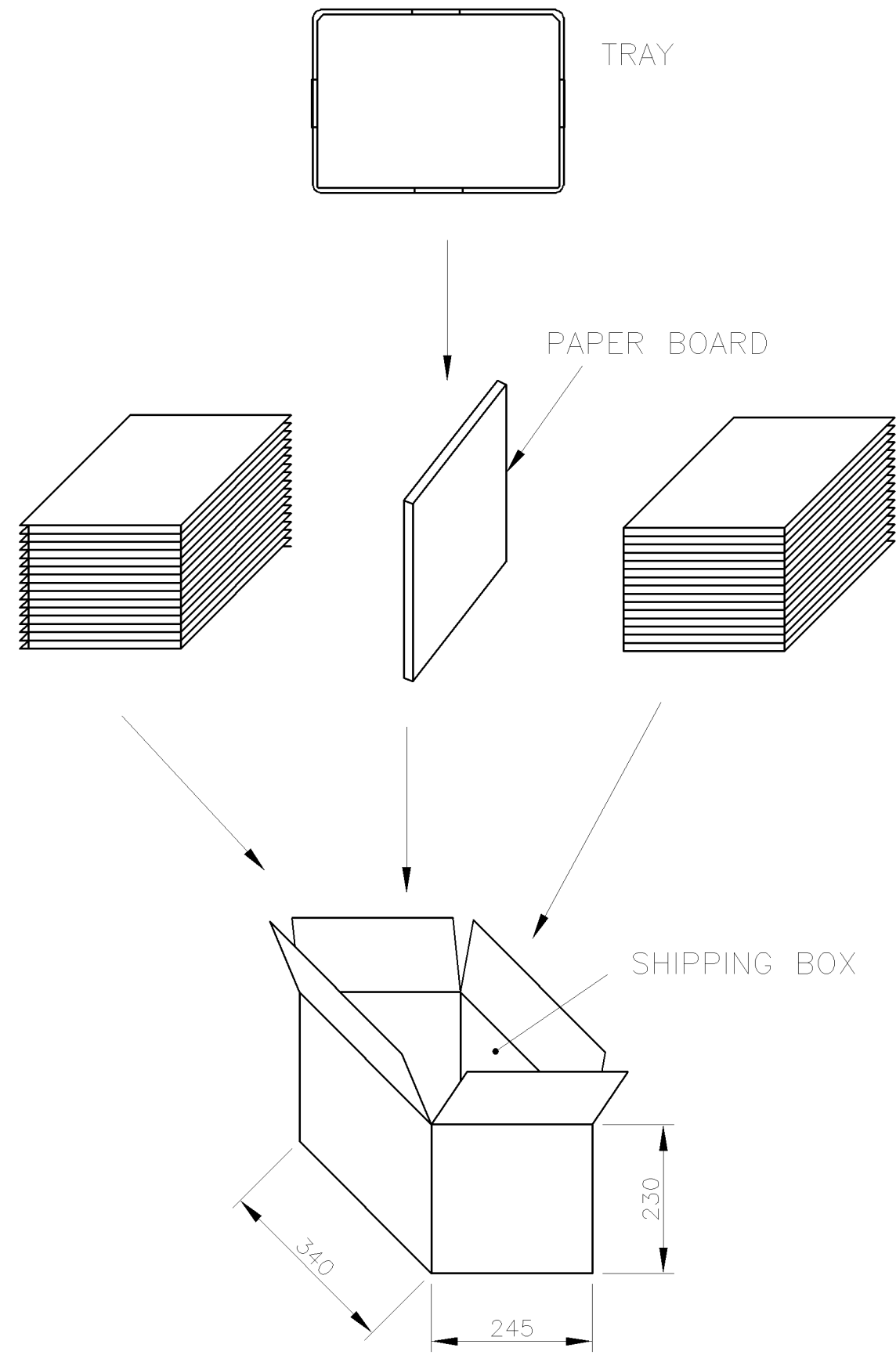

150	56	8400	9.2	6.7	1-1734328-1
PCS/TRAY	TRAYS/BOX	QUANTITY	G/W (Kg)	N/W (Kg)	1734328-1

THIS DRAWING IS A CONTROLLED DOCUMENT.		DWN	Tyco Electronics Corporation Taipei, Taiwan			
DIMENSIONS: MM		CHK				NAME
TOLERANCES UNLESS OTHERWISE SPECIFIED: 0 PLC ± - 1 PLC ± - 2 PLC ± - 3 PLC ± - 4 PLC ± - ANGLES ± -		APVD	MINI USB CONNECTOR, TYPE AB, RCPT, R/A, SMT TYPE			
MATERIAL		PRODUCT SPEC	SIZE	CAGE CODE	DRAWING NO	RESTRICTED TO
FINISH		APPLICATION SPEC	A3	00779	C-1734328	-
		WEIGHT	CUSTOMER DRAWING			SCALE
			SHEET 2 OF 3			REV B

LOC DW DIST

REVISIONS

P	LTR	DESCRIPTION	DATE	DWN	APVD
		SEE SHEET 1.			

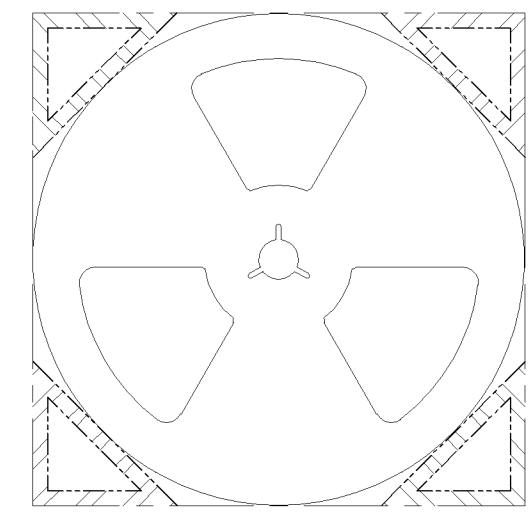
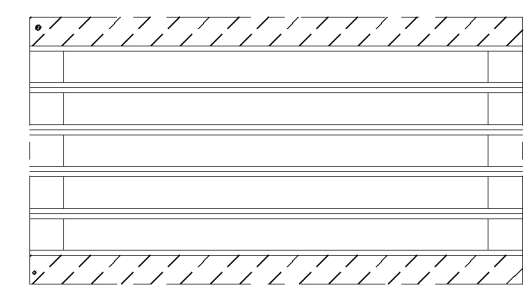
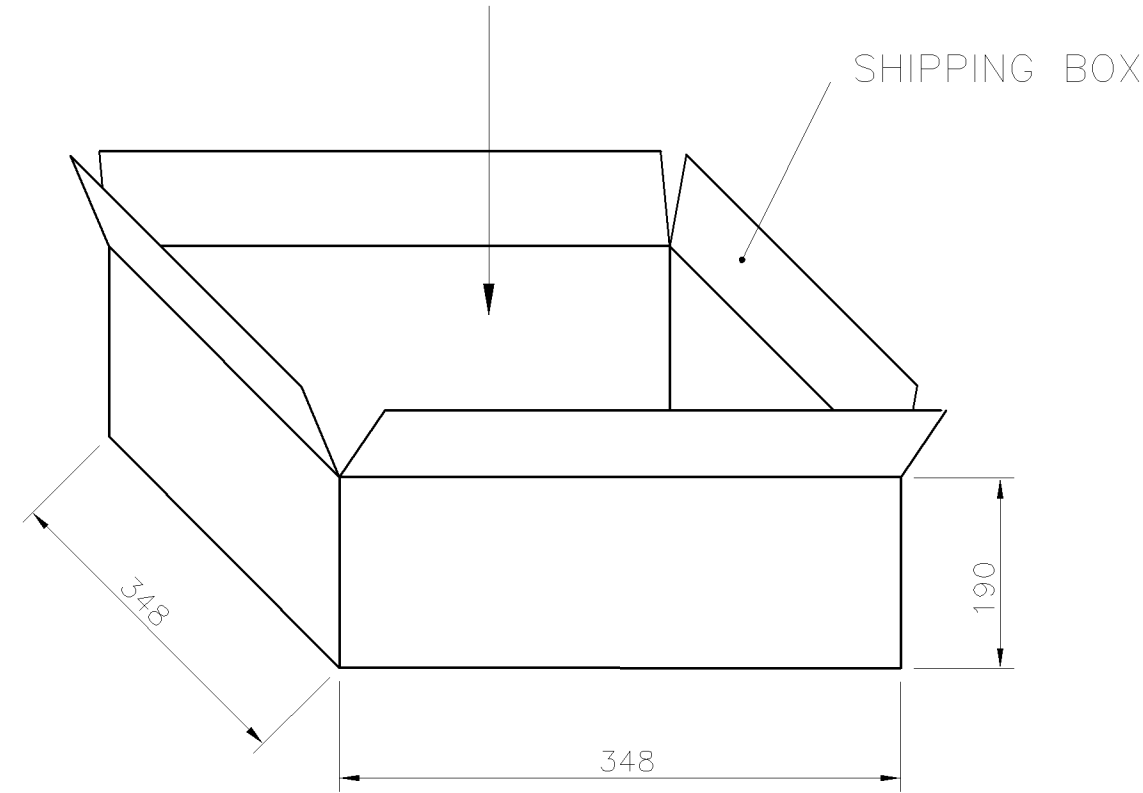
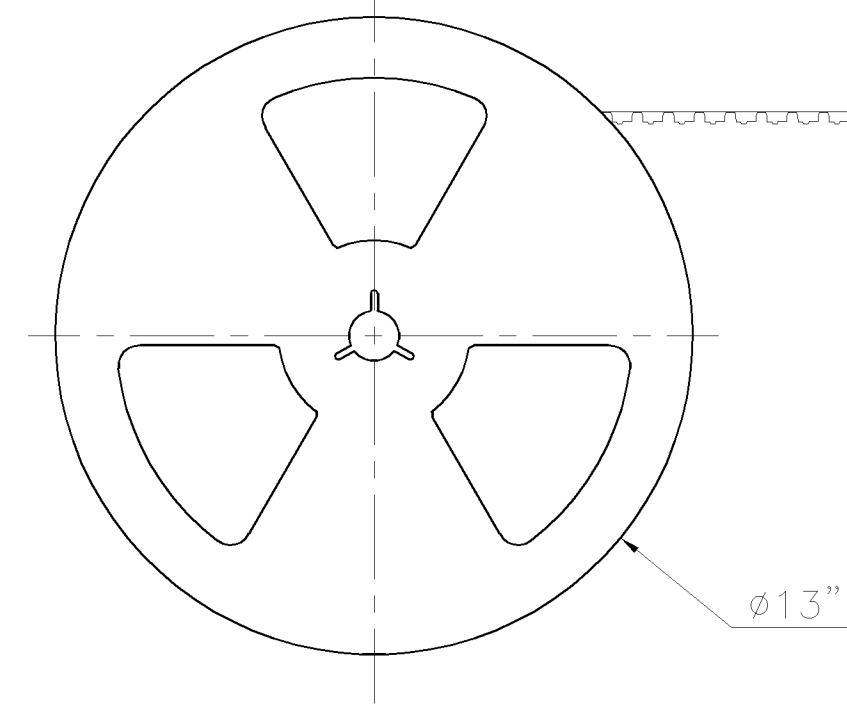
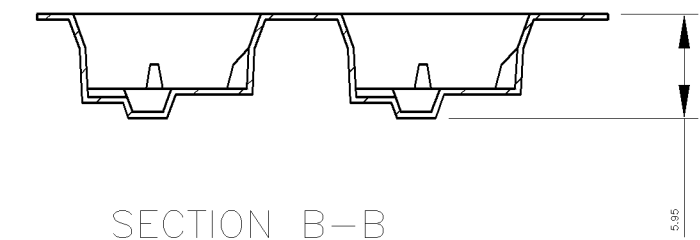
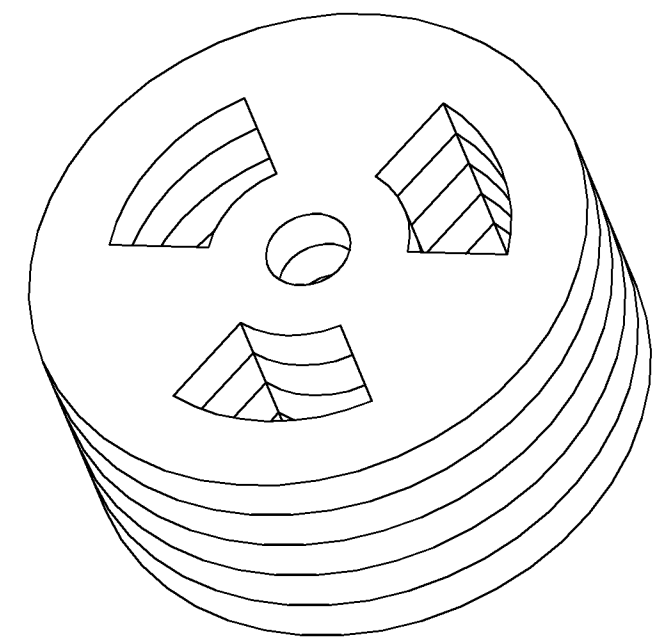
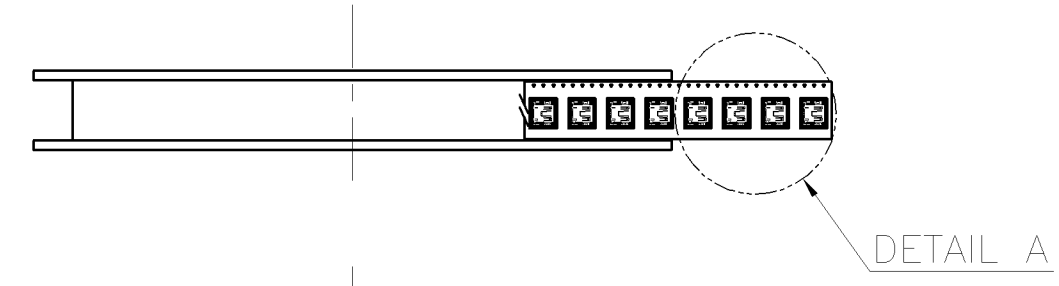
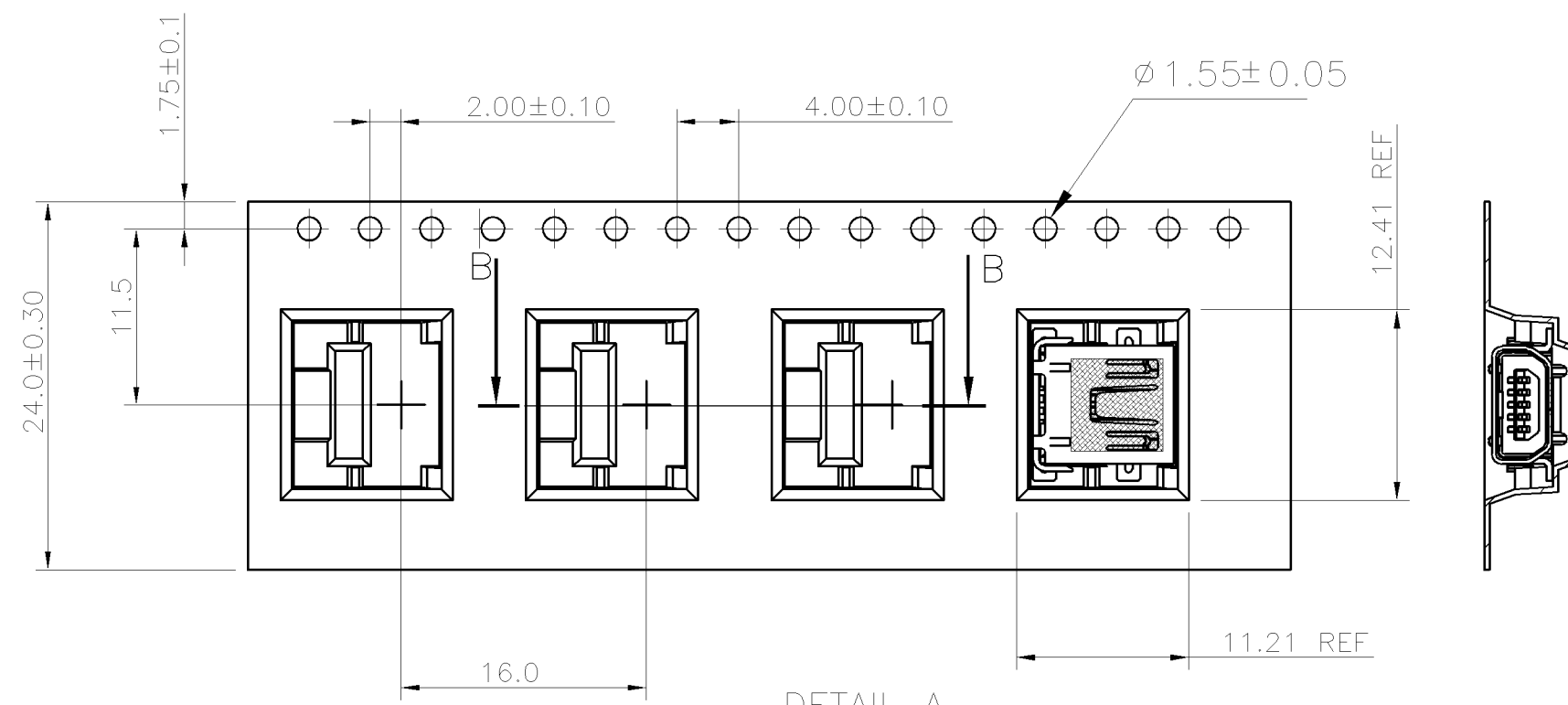

PACKING BOX

PCS/REEL	REELS/BOX	QUANTITY	G/W (Kg)	N/W (Kg)	PART NUMBER
700	5	3500	6.5	5.5	2-1734328-2
					1-1734328-2
					1734328-2

THIS DRAWING IS A CONTROLLED DOCUMENT.		DWN	Tyco Electronics Corporation Taipei, Taiwan			
DIMENSIONS: MM		CHK				
TOLERANCES UNLESS OTHERWISE SPECIFIED: 0 PLC ± - 1 PLC ± - 2 PLC ± - 3 PLC ± - 4 PLC ± - ANGLES ± - FINISH		APVD	NAME			
MATERIAL		PRODUCT SPEC	MINI USB CONNECTOR, TYPE AB, RCPT, R/A, SMT TYPE			
		APPLICATION SPEC	SIZE	CAGE CODE	DRAWING NO	RESTRICTED TO
		WEIGHT	A3	00779	C-1734328	
CUSTOMER DRAWING			SCALE	SHEET	REV	
				3 OF 3	B	