

LOC	DIST	REVISIONS					
DW		P	LTR	DESCRIPTION	DATE	DWN	APVD
		C		REVISED (ECR-08-021707)	28AUG08	SC	WK

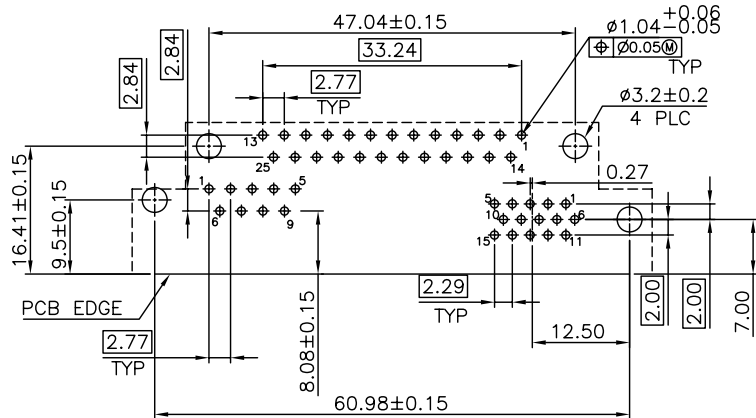

RECOMMENDED P.C.B. LAYOUT
P.C.B. THICKNESS=1.6mm

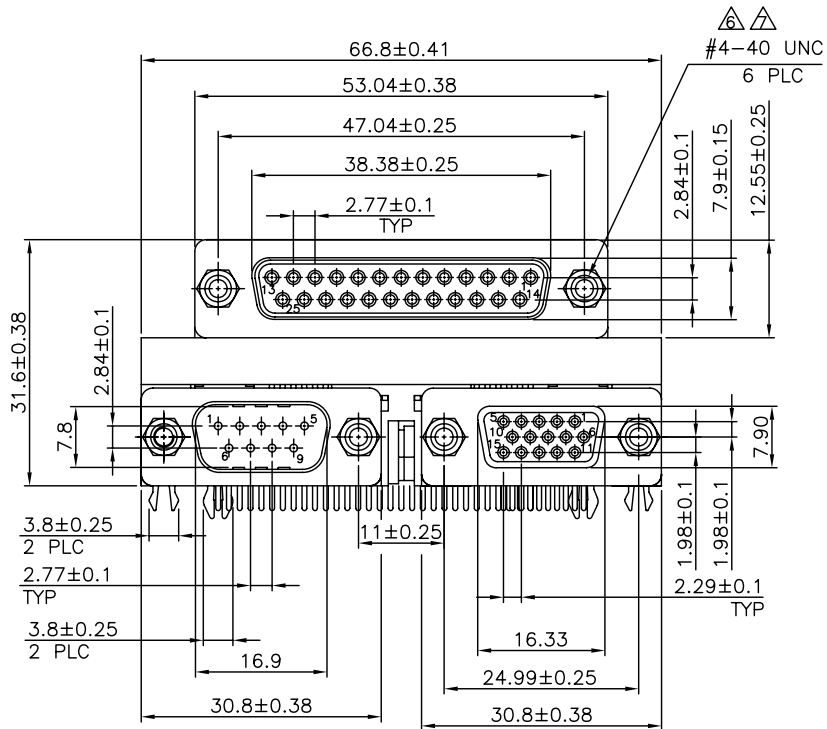
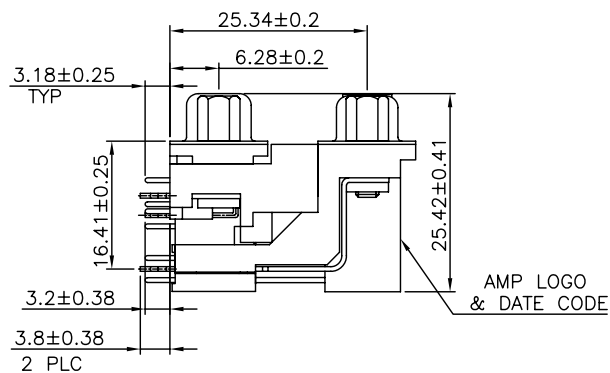
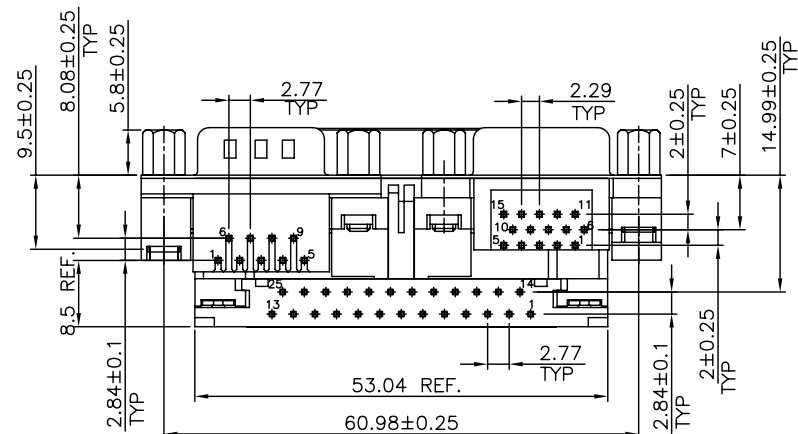

NOTES:

- MATERIAL:
 - HOUSING/BACK COVER: THERMOPLASTIC(PBT), UL94V-0; COLOR: SEE TABLE.
 - PLUG CONTACT: BRASS.
 - RCPT. CONTACT: PHOSPHOR BRONZE.
 - BOARDLOCK: BRASS.
 - BRACKET: THERMOPLASTIC(PBT) UL94V-0, COLOR BURGUNDY
 - SHELL: STEEL.
 - SCREW: BRASS.
 - FINISH:

CONTACT: GOLD PLATING ON CONTACT AREA [SEE TABLE], 2.54um[100u"] MIN. BRIGHT TIN PLATED ON SOLDERTAIL, 1.27um[50u"] MIN. NICKEL UNDERPLATED OVERALL.

BOARD LOCK: 1.524um[60u"] MIN. BRIGHT TIN PLATED OVERALL 1.25um[50u"] MIN. NICKEL UNDERPLATED OVERALL

SCREW: 1.25um[50u"] MIN. NICKEL PLATED

SHELL: 1.524um[60u"] MIN. BRIGHT TIN PLATED OVERALL.
 - WAVE SOLDER CAPABLE TO 265°C PER TE SPEC. 109-202, CONDITION B.
 - RECOMMENDED PCB THICKNESS: 1.6mm
 - THREADED INSERTS AND SCREWLOCKS MUST WITHSTAND 5 kg-cm MAX. TORQUE.
- △ SCREW IS OPTIONAL.(SEE TABLE FOR DETAIL)
 △ RECOMMENDED SCREW LENGTH 5.3mm MIN. (FOR W/O SCREW OPTIONAL)

TURQUOISE (322C)	BLACK	BURGUNDY (235C)	GOLD FLASH	W/O	6-1734198-1	
	BLUE (661C)		30u" MIN.		5-1734198-1	
			15u" MIN.		4-1734198-1	
	PLUG 9P HSG COLOR	RCPT 15P HSG COLOR	RCPT 25P HSG COLOR	30u" MIN.	W/	3-1734198-1
				15u" MIN.		2-1734198-1
				GOLD FLASH	W/O	1-1734198-1
			GOLD FLASH	W/	1734198-1	
			GOLD PLATING	SCREWLOCK △△	PART NUMBER	

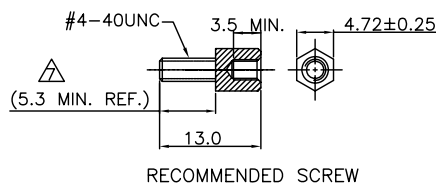

THIS DRAWING IS A CONTROLLED DOCUMENT.

DIMENSIONS: MM

TOLERANCES UNLESS OTHERWISE SPECIFIED:

0 PLC	± 0.5
1 PLC	± 0.3
2 PLC	± 0.2
3 PLC	± 0.15
4 PLC	± -
ANGLES	± 3'

MATERIAL: SEE NOTE

FINISH: SEE NOTE

THIS DRAWING IS A CONTROLLED DOCUMENT.

DWN S. CHIEN 28AUG2008

CHK S. CHIEN 28AUG2008

APVD W. KODAMA 28AUG2008

PRODUCT SPEC: 108-57517

QUALIFICATION TEST REPORT: 501-57590

WEIGHT: SEE PACKAGE

CUSTOMER DRAWING

Tyco Electronics Corporation
Taipei, Taiwan

NAME: STACKED ASS'Y, 25 POS RCPT OVER 9 POS PLUG & 15 POS RCPT., .750 STACK HEIGHT, AMPLIMITE

SIZE: A3

CAGE CODE: 00779

DRAWING NO: C=1734198

RESTRICTED TO: -

SCALE: -

SHEET: 1 OF 4

REV: C

THIS DRAWING IS UNPUBLISHED.

RELEASED FOR PUBLICATION AUG ,2006.

© COPYRIGHT BY TYCO ELECTRONICS CORPORATION. ALL RIGHTS RESERVED.

LOC	DIST	REVISIONS			
P	LTR	DESCRIPTION	DATE	DWN	APVD
		SEE SHEET 1.			

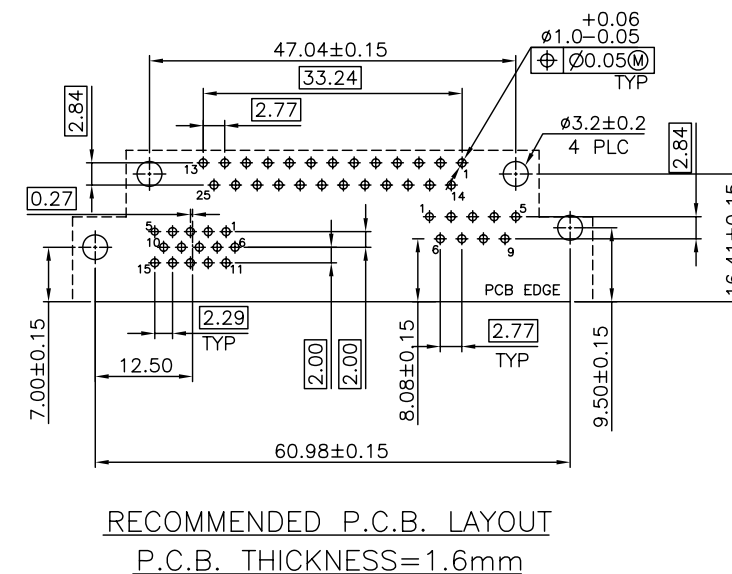
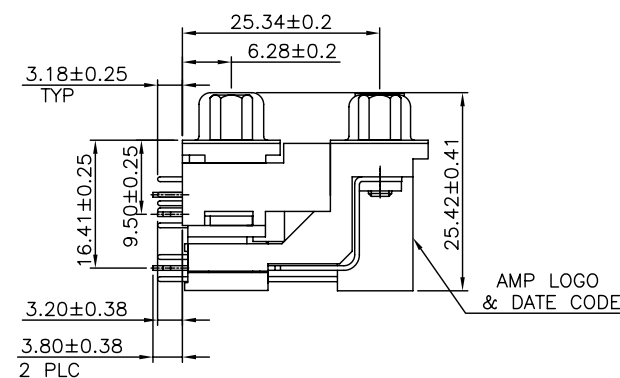
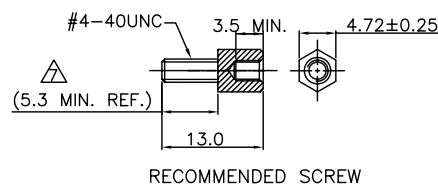
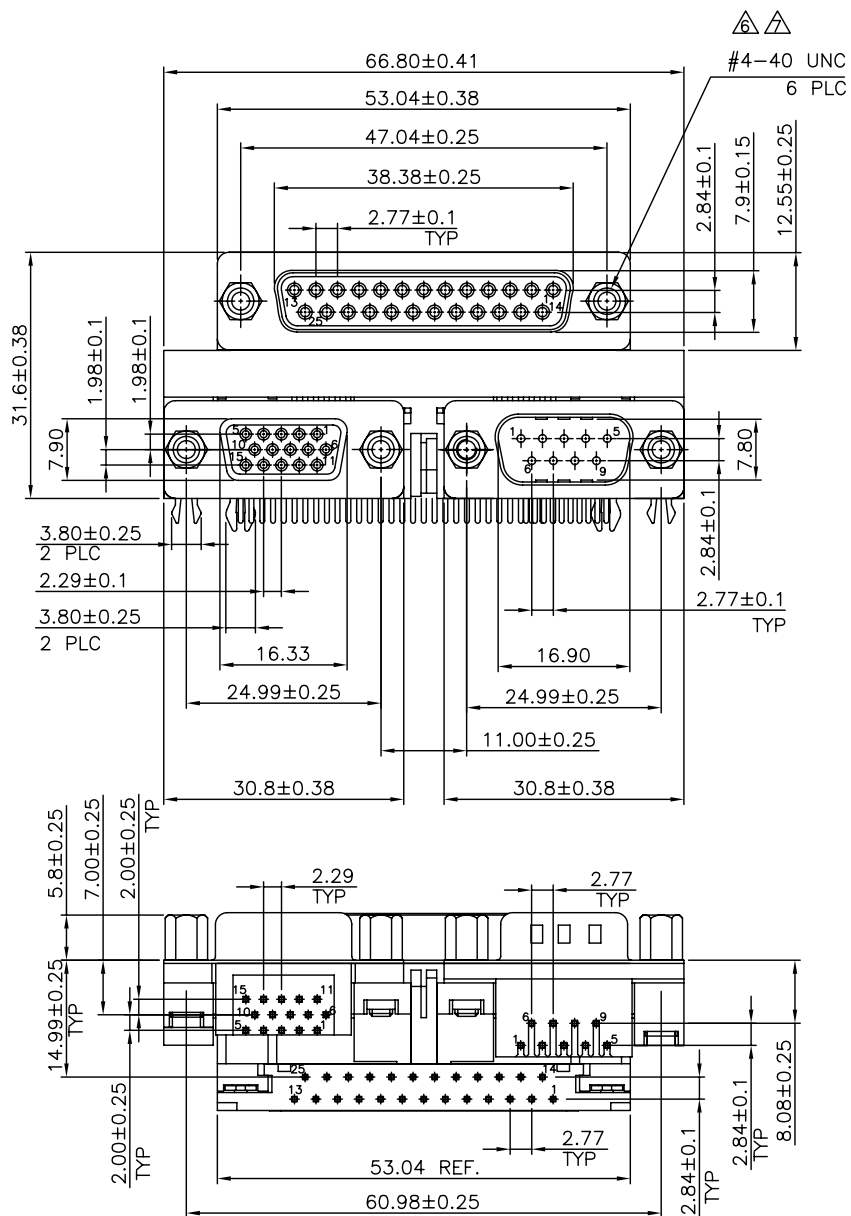

TURQUOISE (322C)	BLUE (661C)	BURGUNDY (235C)	GOLD FLASH	W/O	1-1734198-2
				W/	1734198-2
PLUG 9P HSG COLOR	RCPT 15P HSG COLOR	RCPT 25P HSG COLOR	GOLD PLATING	SCREWLOCK	PART NUMBER

THIS DRAWING IS A CONTROLLED DOCUMENT.		DWN	Tyco Electronics Corporation Taipei, Taiwan		
DIMENSIONS: MM		CHK	NAME		
TOLERANCES UNLESS OTHERWISE SPECIFIED:		APVD	STACKED ASS'Y, 25 POS RCPT OVER 9 POS PLUG & 15 POS RCPT., .750 STACK HEIGHT, AMPLIMITE		
0 PLC ± -		PRODUCT SPEC	SIZE		
1 PLC ± -		APPLICATION SPEC	CAGE CODE		
2 PLC ± -		WEIGHT	DRAWING NO		
3 PLC ± -			RESTRICTED TO		
4 PLC ± -			A3 00779 C=1734198		
ANGLES ± -			SCALE		
FINISH			SHEET 2 OF 4		
			REV C		

THIS DRAWING IS UNPUBLISHED.

RELEASED FOR PUBLICATION

AUG ,2006.

© COPYRIGHT - BY TYCO ELECTRONICS CORPORATION.

ALL RIGHTS RESERVED.

LOC

DIST

REVISIONS

DW

P

LTR

DESCRIPTION

DATE

DWN

APVD

SEE SHEET 1.

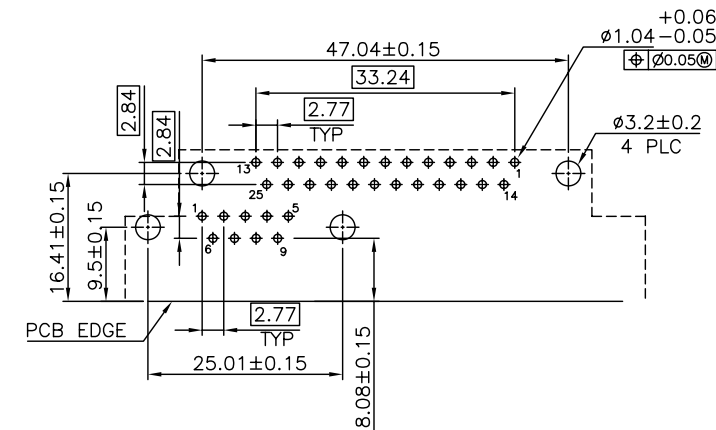
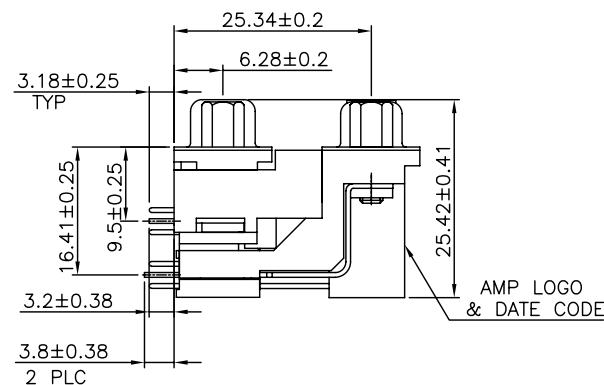
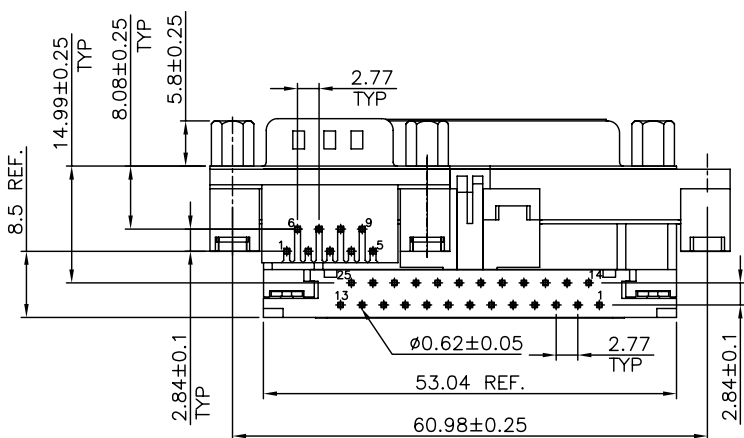
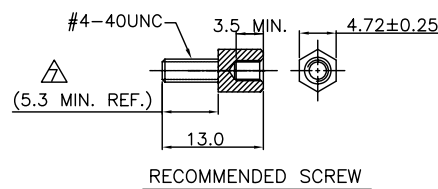
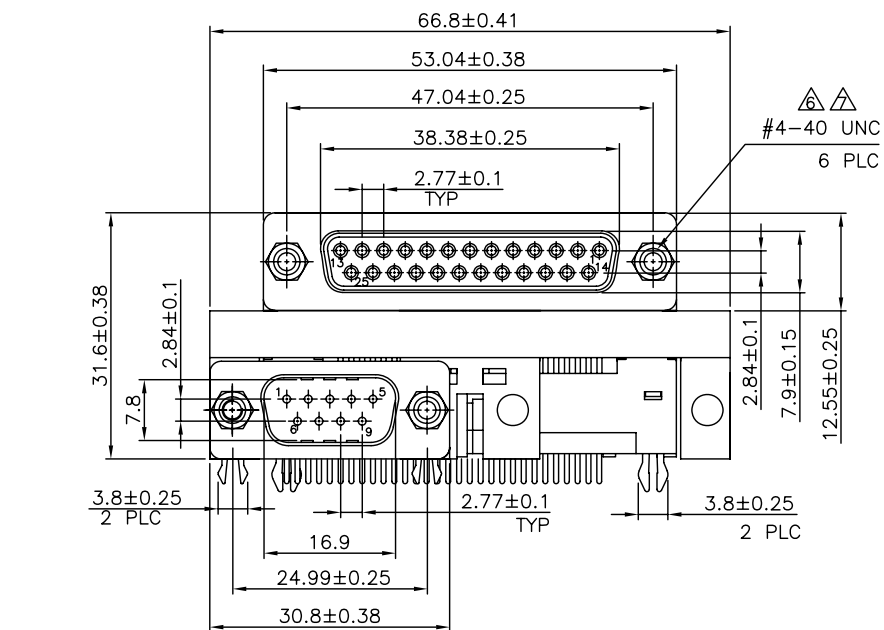

RECOMMENDED P.C.B. LAYOUT
P.C.B. THICKNESS=1.6mm

TURQUOISE (322C)	BURGUNDY (235C)	30u" MIN.	W/	3-1734198-3
		15u" MIN.		2-1734198-3
PLUG 9P HSG COLOR	RCPT 25P HSG COLOR	GOLD FLASH	W/O	1-1734198-3
		GOLD PLATING	W/	1734198-3
		SCREWLOCK		PART NUMBER

THIS DRAWING IS A CONTROLLED DOCUMENT.		DWN		Tyco Electronics Corporation Taipei, Taiwan	
DIMENSIONS: MM		CHK		NAME	
TOLERANCES UNLESS OTHERWISE SPECIFIED:		APVD		STACKED ASS'Y, 25 POS RCPT OVER 9 POS PLUG & 15 POS RCPT., .750 STACK HEIGHT, AMPLIMITE	
0 PLC ± -		PRODUCT SPEC		SIZE	
1 PLC ± -		APPLICATION SPEC		CAGE CODE	
2 PLC ± -		WEIGHT		DRAWING NO	
3 PLC ± -		CUSTOMER DRAWING		RESTRICTED TO	
4 PLC ± -				A3 00779 C=1734198	
ANGLES ± -				SCALE	
FINISH				SHEET 3 of 4	
				REV C	

THIS DRAWING IS UNPUBLISHED.

RELEASED FOR PUBLICATION

AUG ,2006.

© COPYRIGHT BY TYCO ELECTRONICS CORPORATION. ALL RIGHTS RESERVED.

LOC DW

DIST

REVISIONS

P	LTR	DESCRIPTION	DATE	DWN	APVD
		SEE SHEET 1.			

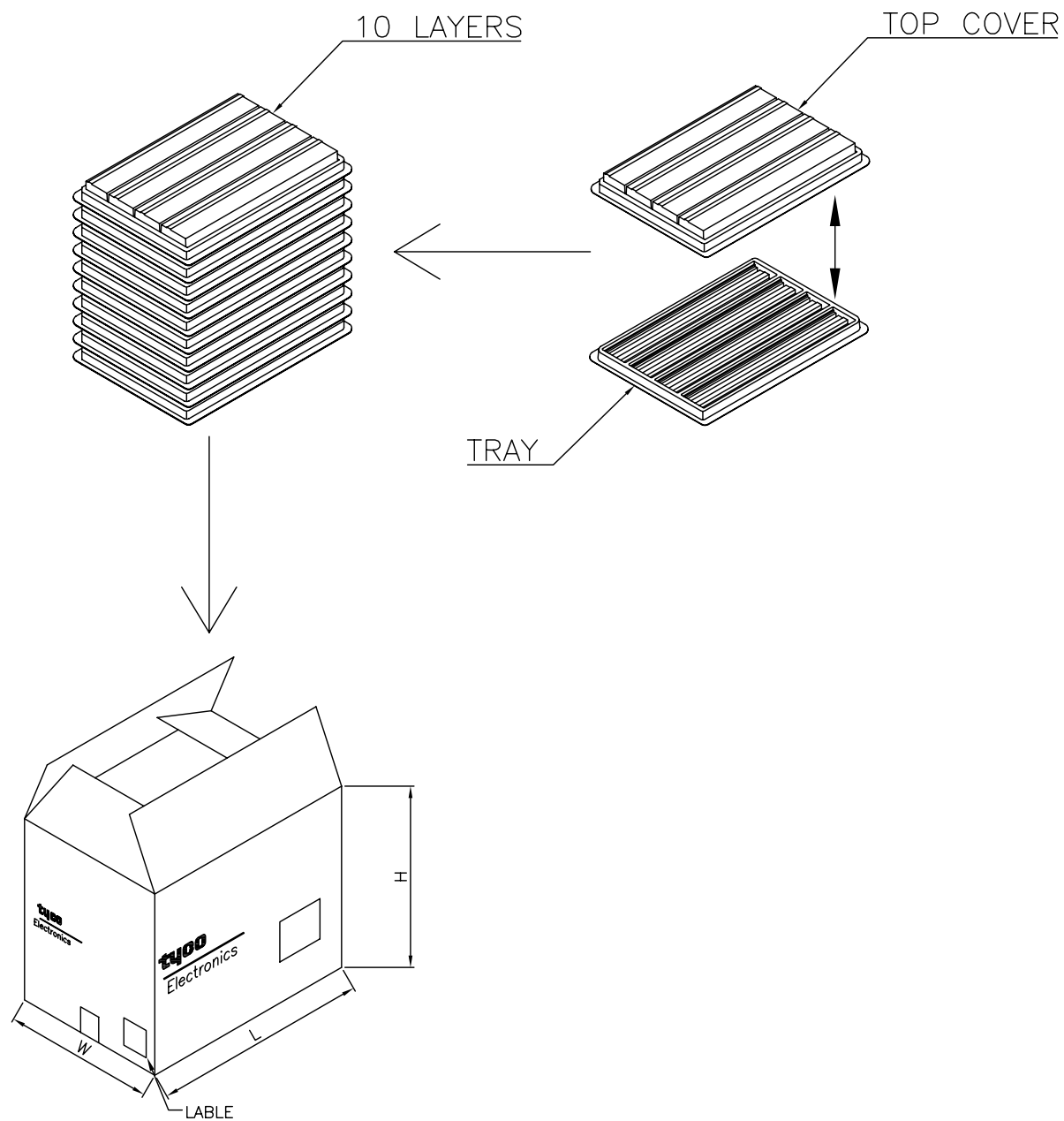

NOTES:

- MATERIAL:
TRAY: PS or PET
- DIMENSION:
TRAY: L=315, W=215, H=30
SHIPPING BOX: L=335, W=230, H=280
- QUANTITY:

PIN NO.	25F/9M-HD15F (25F/HD15F-9M)		25F/9M-0	
	W/	W/O	W/	W/O
SCREW				
PCS/TRAY	16			
TRAY/CARTON	10			
PCS/CARTON	160			
NET. Wt.(Kg)	7.93	7.0	6.68	6.09
GROSS Wt.(Kg)	9.60	8.5	8.18	7.59

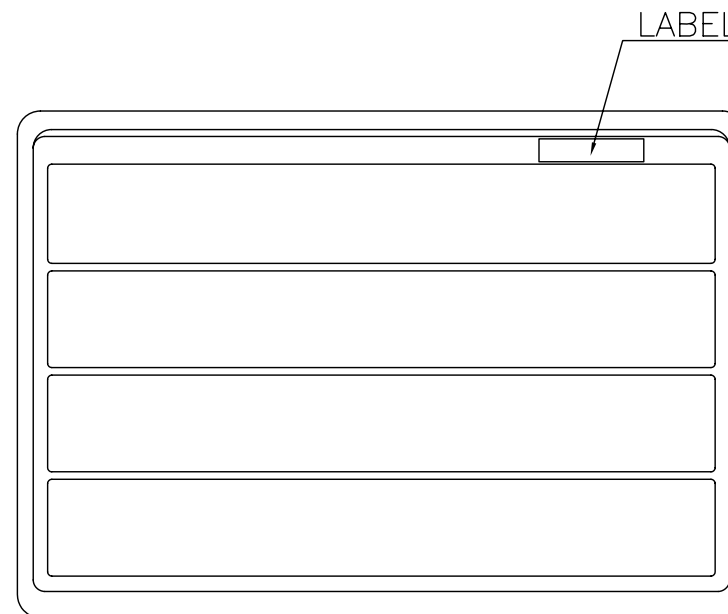

THIS DRAWING IS A CONTROLLED DOCUMENT.		DWN		Tyco Electronics Corporation Taipei, Taiwan	
DIMENSIONS: MM		CHK		NAME	
TOLERANCES UNLESS OTHERWISE SPECIFIED:		APVD		STACKED ASS'Y, 25 POS RCPT OVER 9 POS PLUG & 15 POS RCPT., .750 STACK HEIGHT, AMPLIMITE	
0 PLC ± -		PRODUCT SPEC		SIZE	
1 PLC ± -		APPLICATION SPEC		CAGE CODE	
2 PLC ± -		WEIGHT		DRAWING NO	
3 PLC ± -		CUSTOMER DRAWING		RESTRICTED TO	
4 PLC ± -		SCALE		A3 00779 C=1734198	
ANGLES ± -		SHEET		4 of 4	
MATERIAL		REV		C	
FINISH					