



# W57 series

## Compact, Push To Reset Only Thermal Circuit Breaker



### Features

- New, compact, design.
- 4 to 20 amp ratings.
- Cannot be manually tripped.
- Button extends for visual trip indication.
- Push button to reset breaker.
- Numerous mounting and termination options.

### Agency Approvals

W57 series is UL 1077 Recognized as Supplementary Protectors, File E69543, for Canada and the United States. Approved to VDE 0642/EN60934 (Circuit Breakers for Equipment) License Number 40007874 (excludes models rated 4A and >15A). CCC mark compliant, certificate 2004010307123217.

Users should thoroughly review the technical data before selecting a product part number. It is recommended that users also seek out the pertinent approvals files of the agencies/laboratories and review them to ensure the product meets the requirements for a given application.

### Electrical Data @ 25°C

**Calibration:** Will continuously carry 100% of rating.  
May trip between 101% and 134%, but must trip at 135% of rating within one hour at +25°C.

**Dielectric Strength:** 1,500VAC (60 seconds).

**Insulation Resistance:** 100 megohms.

**Maximum Operating Voltages:** 50VDC; 250VAC, 50/60 Hz.

**Interrupt Capacity:** 1,000 amps in accordance with UL standard 1077.  
**Resettable Overload Capacity:** Ten times rated current.  
**Reset Time:** 60 seconds.

### Typical Resistance vs. Current Rating @ +25°C

Current Rating in Amps	Typical Resistance in Ohms	Current Rating in Amps	Typical Resistance in Ohms
4.0	0.062	10.0	0.025
5.0	0.050	12.0	0.021
6.0	0.042	15.0	0.017
7.0	0.036	20.0	0.012
8.0	0.031		

### Mechanical/Environmental Data

**Operating Temperature Range:** 0°C to +60°C.  
**Termination:** .250" (6.35mm) quick connects.  
**Mounting:** Various options. See Ordering Information and drawings.  
**Approximate Weight:** 0.5 oz. (14.3g).

### Time vs. Current Trip Curve @ +25°C

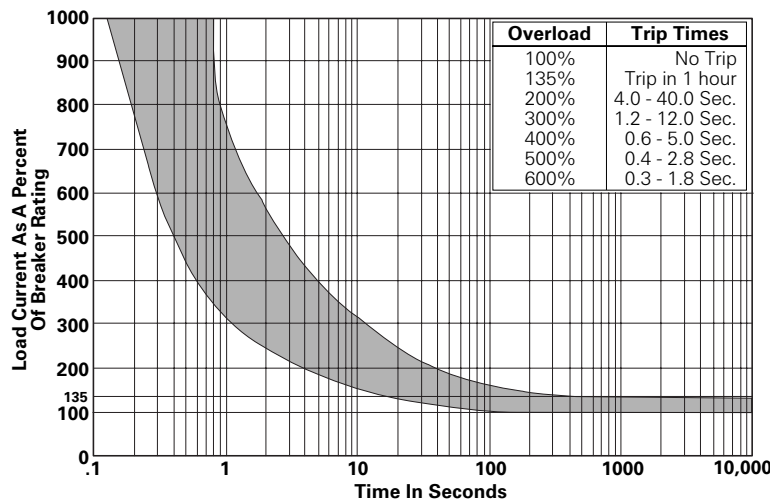

### Outline Dimensions

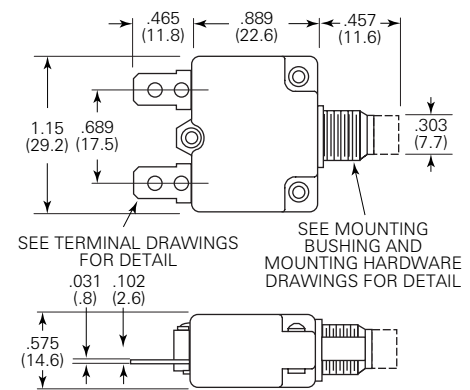

### Optional Protective Boot

Silicone rubber boot is bonded to integral aluminum nut.

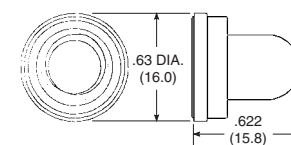

**1-1423696-5**  
Black boot for W57 with 3/8"-24 bushing.

**1-1423696-7**  
Clear boot for W57 with 3/8"-24 bushing.

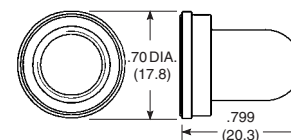

**1-1423696-4**  
Black boot for W57 with M11 X 1.0 bushing.

**1-1423696-6**  
Clear boot for W57 with M11 X 1.0 bushing.

### Ambient Compensation Table

Ambient Temperature in °C	Rating Correction Factor	
	3-6A Models	7-20A Models
10	.80	.80
20	.90	.90
25	1.00	1.00
30	1.10	1.05
40	1.25	1.15
50	1.61	1.25
60	2.15	1.40

**To use this chart:** Divide the breaker rating by the correction factor to determine the compensated rating. Calculate the overloads in terms of the compensated rating to use the published trip curve. Do not use these devices outside their specified operating temperature ranges.

**Ordering Information**

<b>Typical Part No. ▶</b>	<b>W</b>	<b>57</b>	<b>-X</b>	<b>B</b>	<b>1</b>	<b>A</b>	<b>4</b>	<b>A</b>	<b>1</b>	<b>0</b>	<b>-4</b>
<b>1. Designator:</b> W = Circuit breaker											
<b>2. Series Number:</b> 57 = Compact, Single Pole, Push-to-Reset, Thermal Model											
<b>3. Circuit Function:</b> X = Series Trip											
<b>4. Button:</b> A = White, plain, no rate marking      C = White with black rate marking (vertical) B = White with red rate marking (vertical)											
<b>5. Mounting Bushing:</b> 1 = 9.8mm x 9.6mm long, plastic      6 = 3/8" (one side flat) x 10.5mm long, metal 2 = 3/8" (one side flat) x 10.5mm long, plastic      7 = 10.8mm x 12.6mm long, metal											
<b>6. Terminals:</b> A = Quick connect .250" (6.35mm) straight											
<b>7. Mounting Hardware:</b> 4 = Metal knurled nut/hex nut      5 = Plastic knurled nut      12 = Metal knurled nut      99 = None											
<b>8. Mounting Hardware Packaging:</b> A = Assembled to bushing      B = Bulk unassembled      C = No mounting hardware.											
<b>9. Maximum Operating Voltage (AC):</b> 1 = 250VAC											
<b>10. Nameplate:</b> 0 = None											
<b>11. Specify Amp Rating:</b> 4†    5    6    7    8    10    12    15    20†    †Not VDE											

**Our authorized distributors are more likely to stock the following items for immediate delivery.**

W57-XB1A4A10-5    W57-XB1A4A10-15    W57-XB1A5A10-5    W57-XB1A5A10-15  
W57-XB1A4A10-10    W57-XB1A4A10-20    W57-XB1A5A10-10    W57-XB1A5A10-20

**ORDERING NOTE:** Many options illustrated below are not listed in the "Ordering Information" chart above. Options denoted by "Special" or "Special Order" in their descriptions are only offered on a special order basis. Additionally, mounting hardware can be ordered separately. These options are subject to extended leadtimes and significant minimum order quantities. Your Tyco Electronics sales engineer must consult with the factory before providing price and availability information regarding these options.

**Mounting Bushings and Recommended Panel Cutouts**

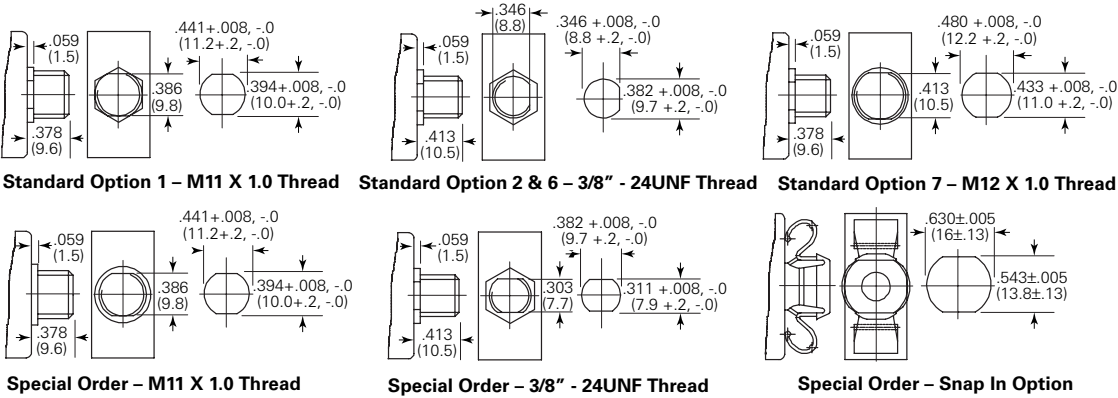

**Termination Options**

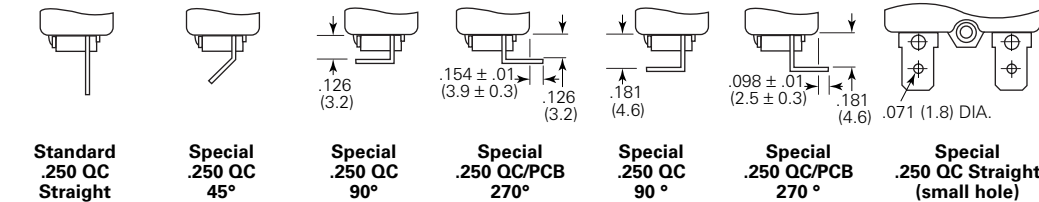

**Mounting Hardware Options**

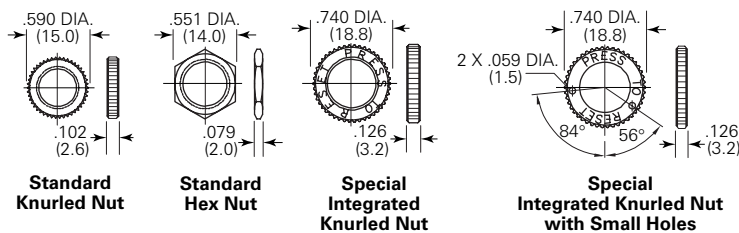

**Optional Nameplates**

