

REVISITONS		DATE	DWN DESS.	APVD APP.
P	LTR REV	DESCRIPTION MODIFICATIONS		
	L	Redessine en CAO et revise EC 7462	31MARS98	O.L
	M	CLARIFICATION	09OCT2000	JJD

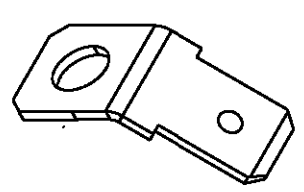

ECHELLE 2:1

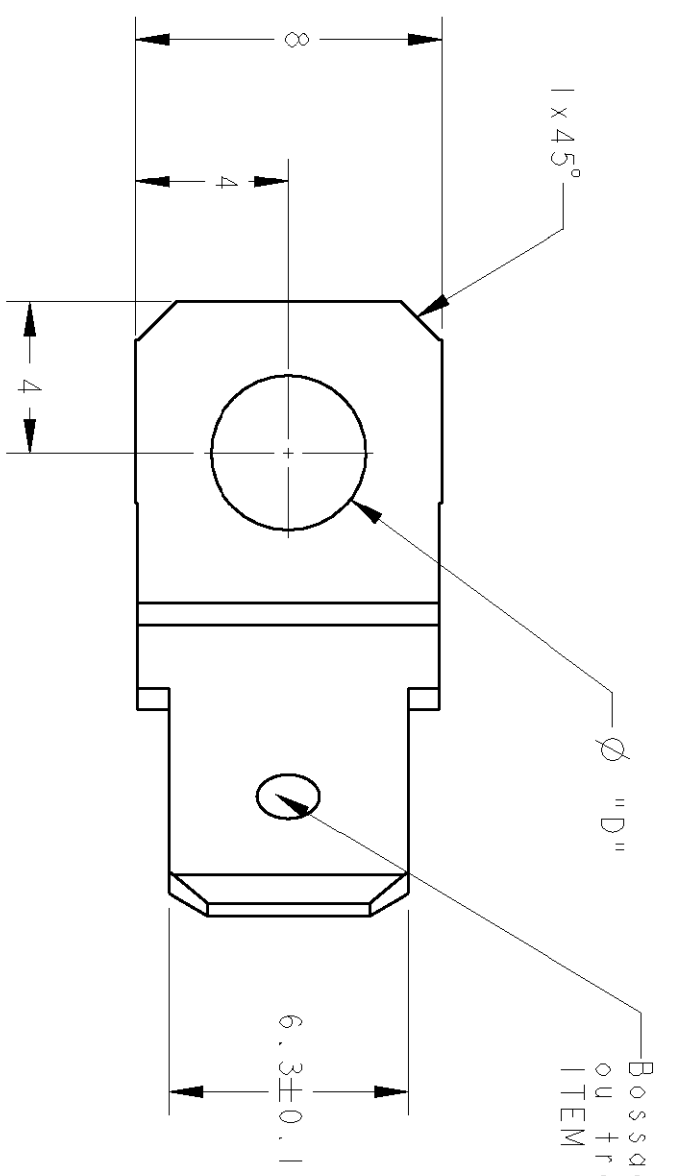
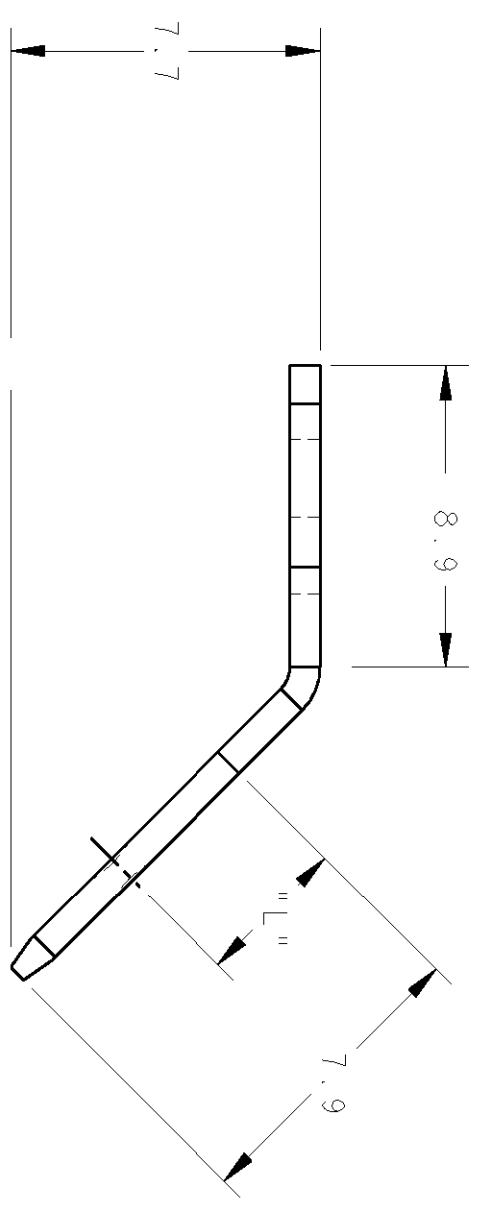

141158-1	dore	4.1	3	bossage
141036-1	brut	3.4	5.2	trou
140829-2	etame	3.4	3	trou
140829-1	brut	3.4	3	trou
140814-2	etame	3.4	4.1	trou
140814-1	brut	3.4	4.1	trou
140856-2	etame	4.1	3.7	bossage
140856-1	brut	4.1	3.7	bossage
140759-1	nickelle	4.1	5.2	bossage
140759-0	etame	4.1	5.2	bossage
140665-0	brut	4.1	5.2	bossage
140660-0	etame	4.1	3	bossage
140659-0	brut	4.1	3	bossage
140598-0	etame	4.1	4.1	bossage
140597-0	brut	4.1	4.1	bossage
Reference	Finition	"L"	"D"	"d"

THIS DRAWING IS A CONTROLLED DOCUMENT FOR TYCO ELECTRONICS CORPORATION
 IT IS SUBJECT SHOULD BE CONTACTED FOR THE LATEST REVISION.
 CE PLAN EST UN DOCUMENT CONTROLÉ PAR AMP INDOCORPATED.
 IL EST SUSCEPTIBLE D'ETRE REVISE. CONTACTER LE SERVICE
 TECHNIQUE D'AMP DE FRANCE POUR OBTENIR LA DERNIERE REVISION.

DWN/DESSINE 30MARS98
 O. LEMPEREUR
 CHK/VERIFIE
 G. ROBERT
 APVD/APPROUVE
 Y. PETRONLIN
 PRODUCT SPEC
 SPEC. PRODUIT
 APPLICATION SPEC
 SPEC. APPLICATION
 WEIGHT
 MASSE APPROX. -

DIMENSIONS:
 mm
 TOLERANCES UNLESS SPECIFIED:
 TOLERANCES NON SPECIFIEES (SUIVY NB DE DECIMALES):
 0 PLC/DEC: ±
 1 PLC/DEC: ±0.2
 2 PLC/DEC: ±
 3 PLC/DEC: ±
 4 PLC/DEC: ±
 ANGLES
 ±30°

NAME
 TITRE
 FASTON TABS BENT 45 .250 series
 LANGUETTE POUR CLIPS

MATERIAL/MATIERE
 LAITON
 FINISH/FINITION
 Voir tablea

SIZE
 FORMAT
 A3
 CAGE CODE
 DRAWING NO
 00779
 UNIFORMENT
 POUR REFERENCE
 SCALE
 ECHELLE
 5
 SHEET
 FEUILLE
 OF
 DE
 REV
 M