

Materials			
No.	Component name	Base material	Finish
1	Housing	High Temp., UL 94V-0, green	
2	End terminal	silver clad copper alloy	5 microinches min. gold
3	Center terminal	copper alloy	5 microinches min. gold
4	Rocker contact	silver clad copper alloy	5 microinches min. gold
5	Actuator	Phenol resin, UL94 HB, black	
6	Plunger	stainless steel	
7	Spring	music wire	
8	Toggle	brass	chrome or Nickel
9	Retainer	Polyamide, UL94 HB, black	
10	Frame	cold rolled steel	zinc or Nickel
11	Bushing	brass	100 microinches min. nickel over 10 microinches min. copper
12	Mounting nuts (2)	brass	200 microinches min. bright nickel
13	Locating ring	cold rolled steel	zinc or Nickel
14	Internal tooth lockwasher	steel	zinc or Nickel

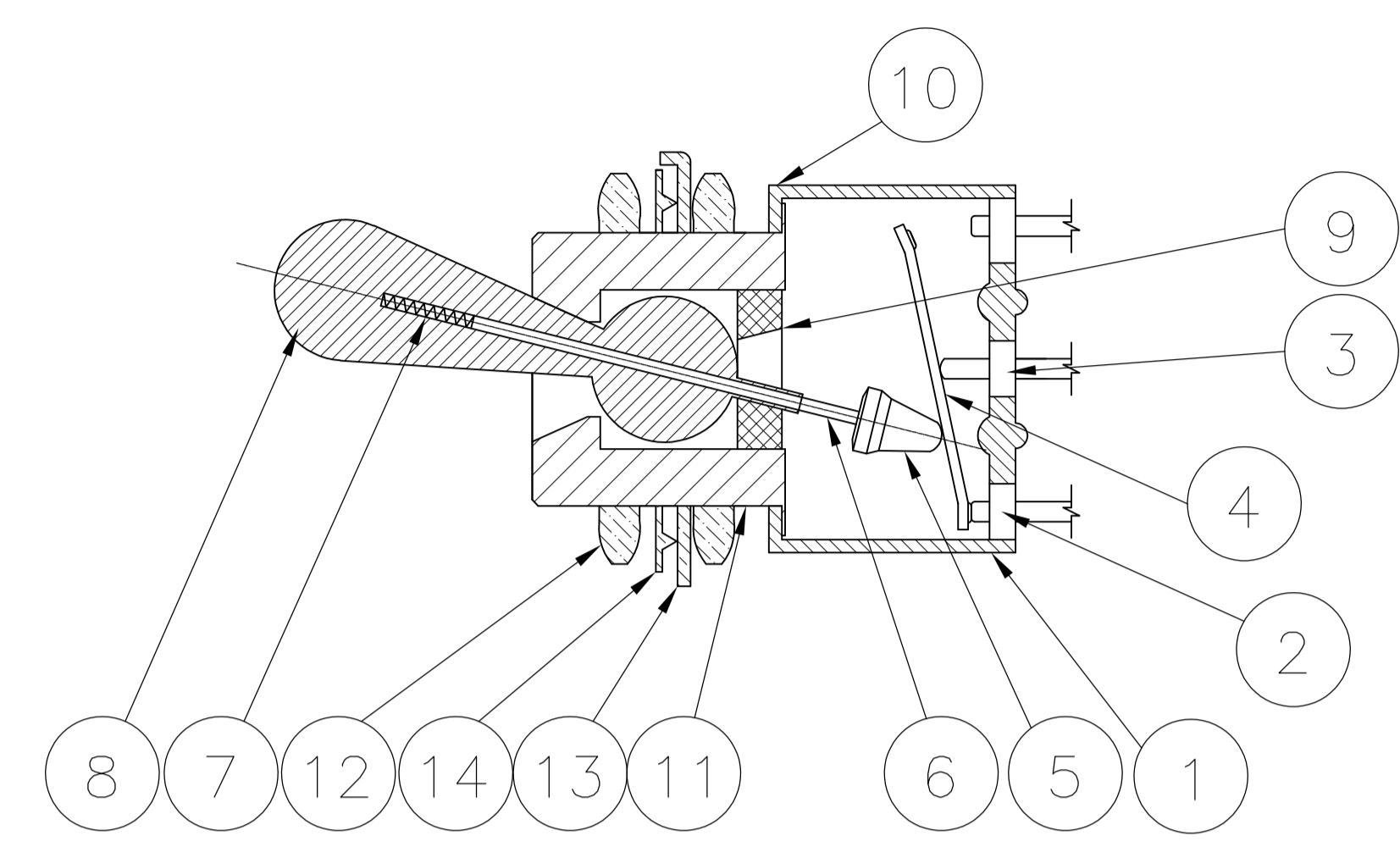
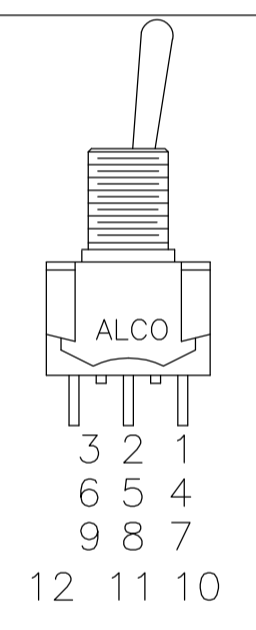
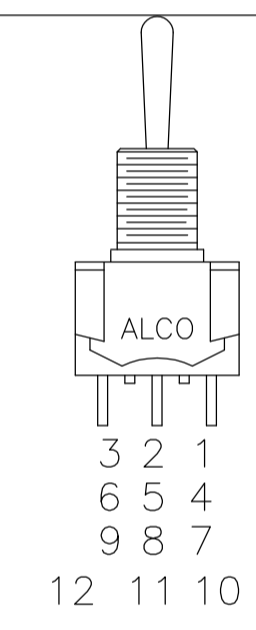
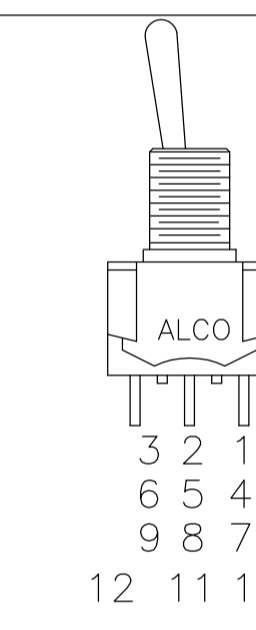

NOT TO SCALE

Specifications—see note 3				
Current rating UL & CSA	6A @ 125 VAC (resistive)			
	3A @ 250 VAC (resistive)			
	4A @ 28 VDC (resistive)			
Termination resistance	20 milliohms max @ 2-4 VDC, 1A			
Insulation resistance	1,000 megohms min.			
Withstanding voltage	1,000 VAC			
Travel	24 +/- 6 degrees			
Actuation force	.05 to 1.5 kgf			
Operating temperature	-20C to +85C			
Storage temperature	-40C to +85C			
Contact timing	break before make			
Terminal seal	epoxy or insert molded			
Durability	Parameter	2 Position	3 Position	Momentary
	mechanical (no load)	150,000	100,000	80,000
	250 VAC (3A resistive)	80,000	60,000	60,000
	125 VAC (6A resistive)	80,000	60,000	60,000
	28 VDC (4A resistive)	60,000	50,000	40,000

Part Number	Alco Model	Poles	Throws	Function	Terminal	A				Comments
3-1437559-2	MTG406P	4	2	ON OFF ON	Wire lug	.453	2-3, 5-6, 8-9, 11-12	Off	2-1, 5-4, 8-7, 11-10	
3-1437559-3	MTG426N	4	2	ON ON	Wire lug	.685	2-3, 5-6, 8-9, 11-12	---	2-1, 5-4, 8-7, 11-10	
3-1437559-1	MTG406N	4	2	ON ON	Wire lug	.453	2-3, 5-6, 8-9, 11-12	---	2-1, 5-4, 8-7, 11-10	
2-1437559-9	MTG306E	3	2	ON OFF ON	Wire lug	.453	2-3, 5-6, 8-9	Off	2-1, 5-4, 8-7	
3-1437559-0	MTG326D	3	2	ON ON	Wire lug	.685	2-3, 5-6, 8-9	---	2-1, 5-4, 8-7	
2-1437559-8	MTG306D	3	2	ON ON	Wire lug	.453	2-3, 5-6, 8-9	---	2-1, 5-4, 8-7	
2-1437559-7	MTG226PA	1	3	ON ON ON	Wire lug	.685	5-6	5-3	5-1	note 6
2-1437559-6	MTG226P	2	2	ON OFF ON	Wire lug	.685	2-3, 5-6	Off	2-1, 5-4	
2-1437559-5	MTG226N	2	2	ON ON	Wire lug	.685	2-3, 5-6	---	2-1, 5-4	
2-1437559-4	MTG206T	2	2	ON OFF(ON)	Wire lug	.453	2-3, 5-6	Off	2-1, 5-4	
2-1437559-3	MTG206S	2	2	(ON) OFF (ON)	Wire lug	.453	2-3, 5-6	Off	2-1, 5-4	
2-1437559-2	MTG206R	2	2	ON (ON)	Wire lug	.453	2-3, 5-6	---	2-1, 5-4	
2-1437559-1	MTG206PA	1	3	ON ON ON	Wire lug	.453	5-6	5-3	5-1	note 6
2-1437559-0	MTG206P	2	2	ON OFF ON	Wire lug	.453	2-3, 5-6	Off	2-1, 5-4	
1-1437559-9	MTG206NPC	2	2	ON ON	PC	.453	2-3, 5-6	---	2-1, 5-4	
1-1437559-8	MTG206N	2	2	ON ON	Wire lug	.453	2-3, 5-6	---	2-1, 5-4	
1-1437559-0	MTG126G	1	2	(ON) OFF (ON)	Wire lug	.685	2-3	Off	2-1	
1-1437559-7	MTG126E	1	2	ON OFF ON	Wire lug	.685	2-3	Off	2-1	
1-1437559-6	MTG126D	1	2	ON ON	Wire lug	.685	2-3	---	2-1	
1-1437559-5	MTG106H	1	2	ON OFF(ON)	Wire lug	.453	2-3	Off	2-1	
1-1437559-4	MTG106G	1	2	(ON) OFF (ON)	Wire lug	.453	2-3	Off	2-1	
1-1437559-3	MTG106F	1	2	ON (ON)	Wire lug	.453	2-3	---	2-1	
1-1437559-2	MTG106E	1	2	ON OFF ON	Wire lug	.453	2-3	Off	2-1	
1-1437559-1	MTG106D	1	2	ON ON	Wire lug	.453	2-3	---	2-1	

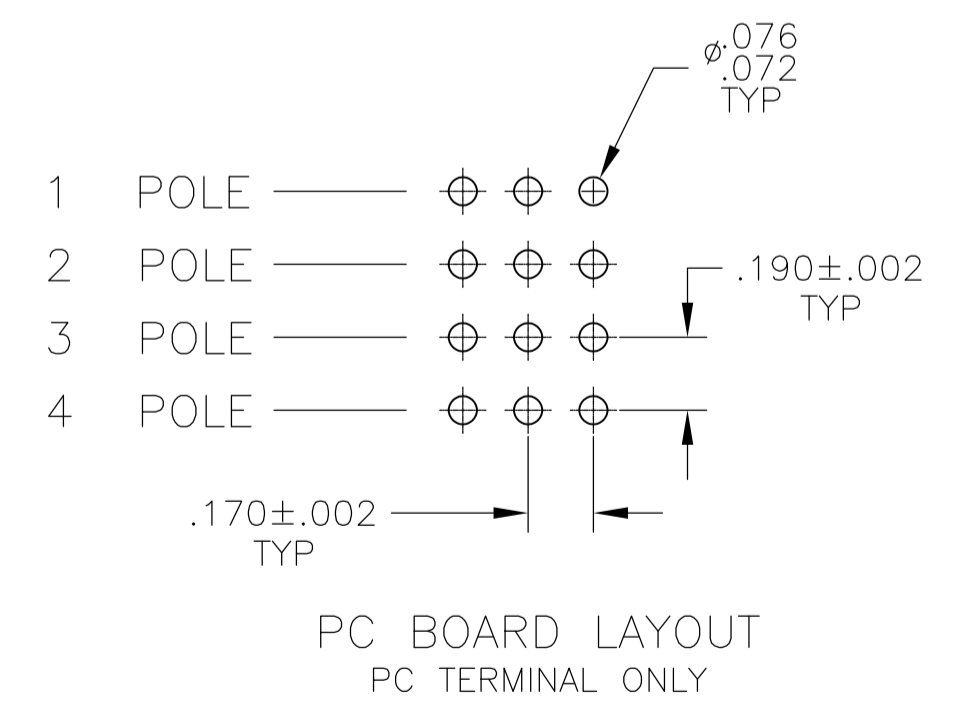
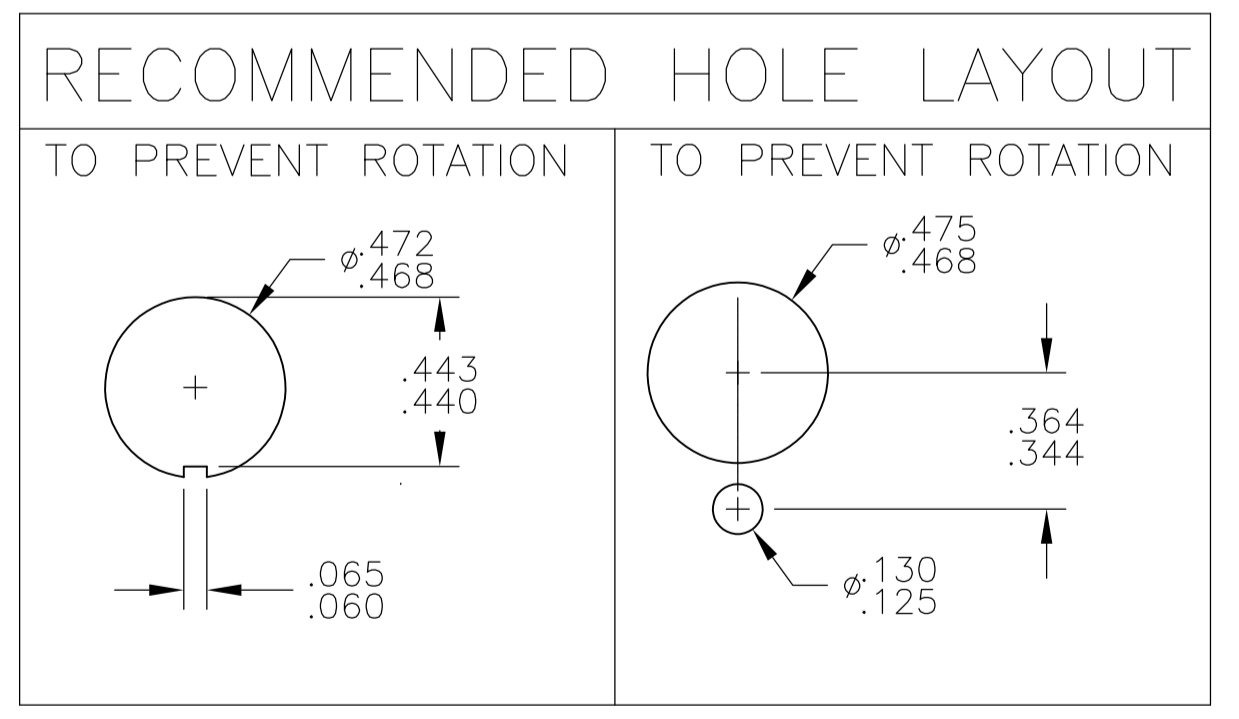

- NOTES:
- TERMINAL NUMBERS ARE FOR REFERENCE ONLY AND DO NOT APPEAR ON THE SWITCHES.
 - EACH SWITCH SUPPLIED WITH THE FOLLOWING MOUNTING HARDWARE:
 - (2) 15/32-32 UNS-2B HEX NUTS
 - (1) INTERNAL TOOTH LOCKWASHER
 - (1) LOCATING RING
 - NEWLY TOOLED SWITCHES TESTED TO AND MEET THE REQUIREMENTS OF UL 1054, SPECIAL USE SWITCHES. NEWLY TOOLED SWITCHES WILL ALSO BE TESTED TO AND MEET TYCO 102-2469 REV 0, MINIATURE SWITCH QUALIFICATION REQUIREMENTS.
 - NEWLY TOOLED SWITCHES ARE UL RECOGNIZED AND CSA CERTIFIED. CONSULT FACTORY FOR UL/CSA INFORMATION ON EXISTING SWITCHES.
 - WIRE LUG CONTACTS WILL ACCEPT 2 #20 AWG SOLID OR STRANDED WIRES.
 - CUSTOMER INSTALLED EXTERNAL JUMPER BETWEEN TERMINALS 2 AND 4 REQUIRED FOR 1 POLE 3 THROW FUNCTION.

7 OBSOLETE

THIS DRAWING IS A CONTROLLED DOCUMENT.

DIMENSIONS: INCHES	TOLERANCES UNLESS OTHERWISE SPECIFIED:	DIN M. BINNER 29DEC03	 Tyco Electronics Corporation Harrisburg, Pa 17105-3608
0 PLC ± -	1 PLC ± -	29DEC03	
2 PLC ± -	3 PLC ± -	29DEC03	NAME: M. ZITTO PRODUCT SPEC: TOGGLE SWITCH, MTG SERIES VERTICAL MOUNT APPLICATION SPEC:
4 PLC ± -	ANGLES ± -		SIZE: A1 CASE CODE: 00779 DRAWING NO: 1-1437559-1 WEIGHT:
MATERIAL:	FINISH:		CUSTOMER DRAWING: SCALE 2:1 SHEET 1 OF 3 REV D1

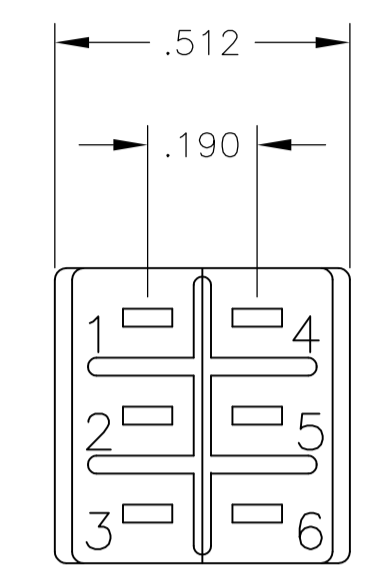
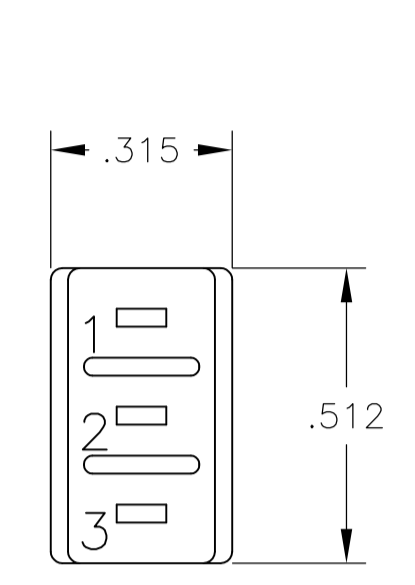
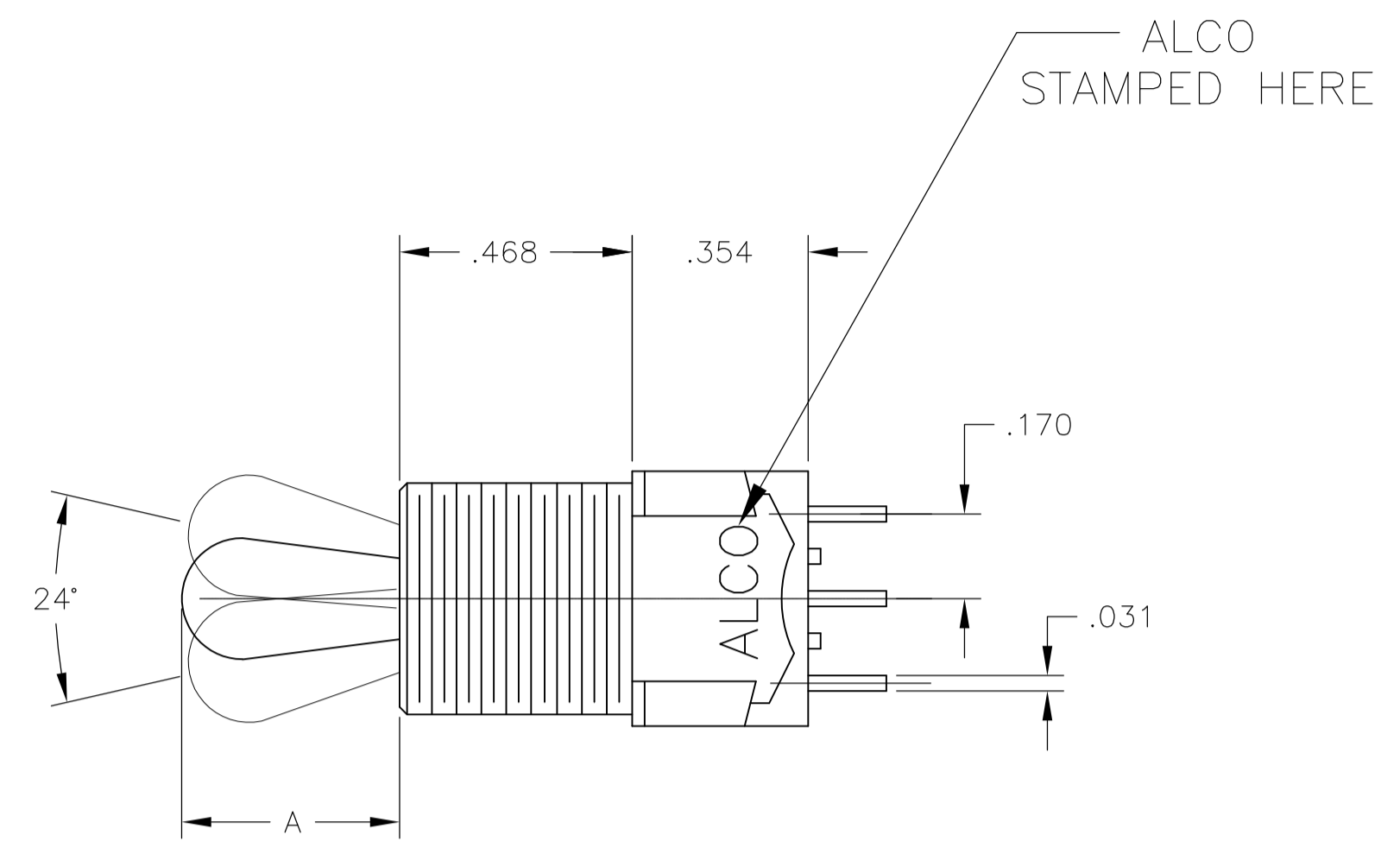

MTG-106

MTG-206

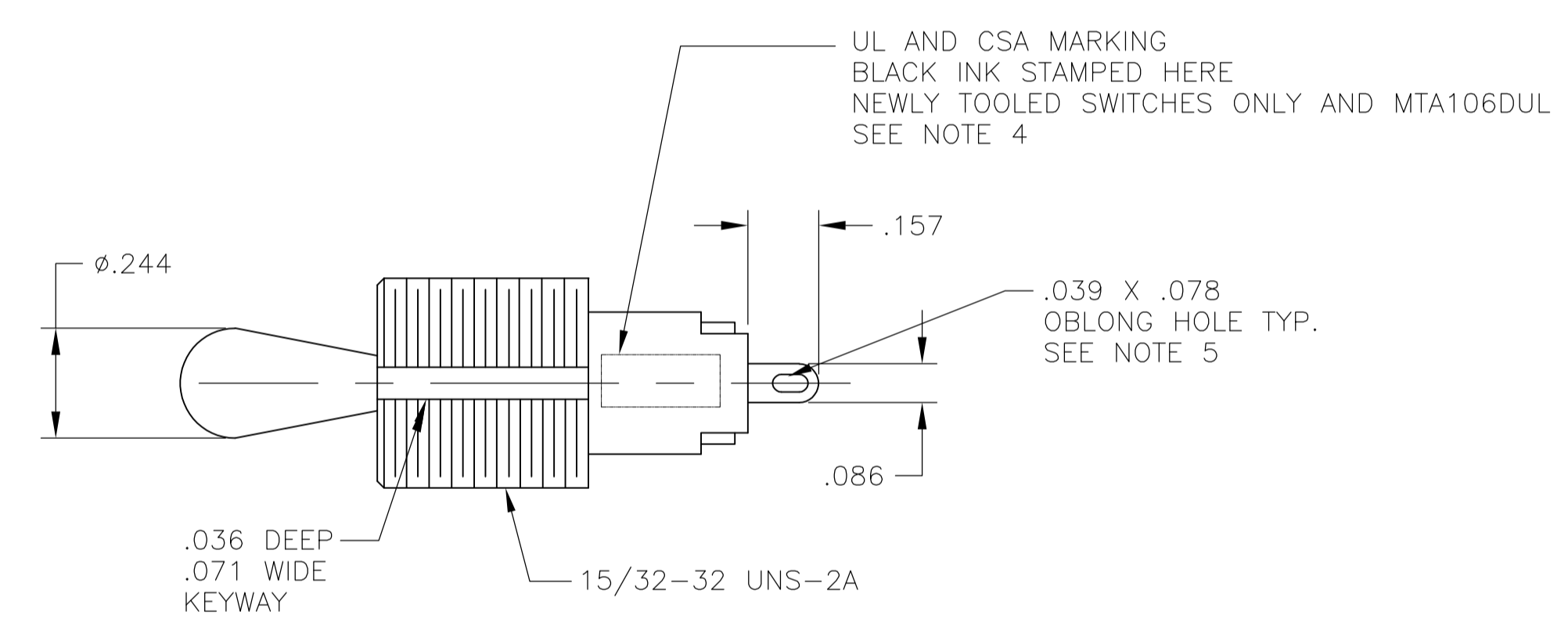
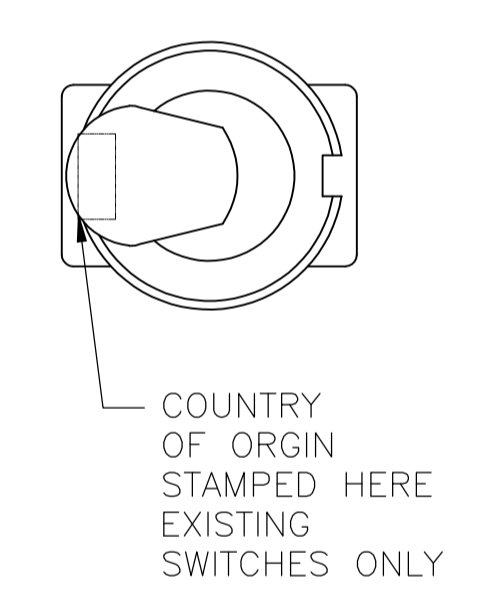

WIRE LUG TERMINAL

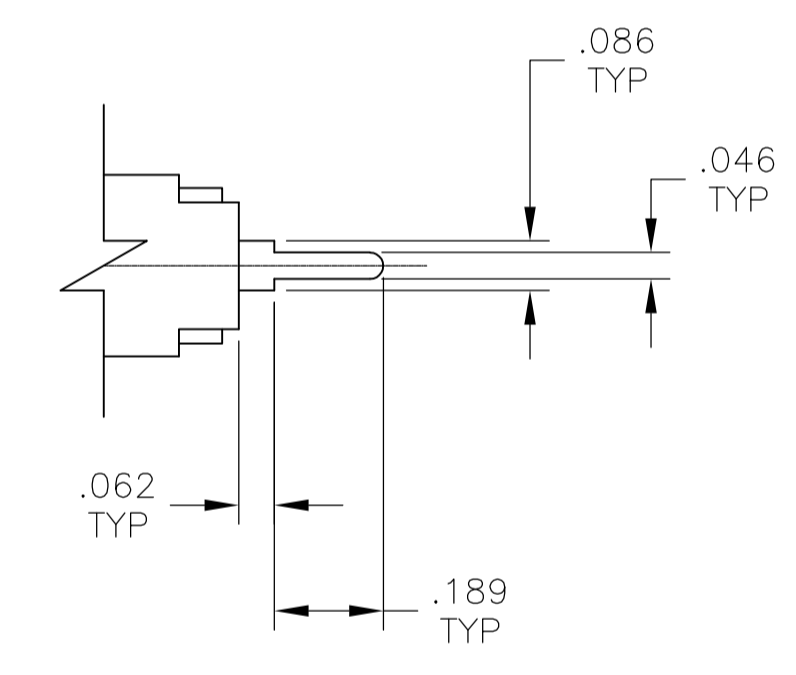

PC TERMINAL

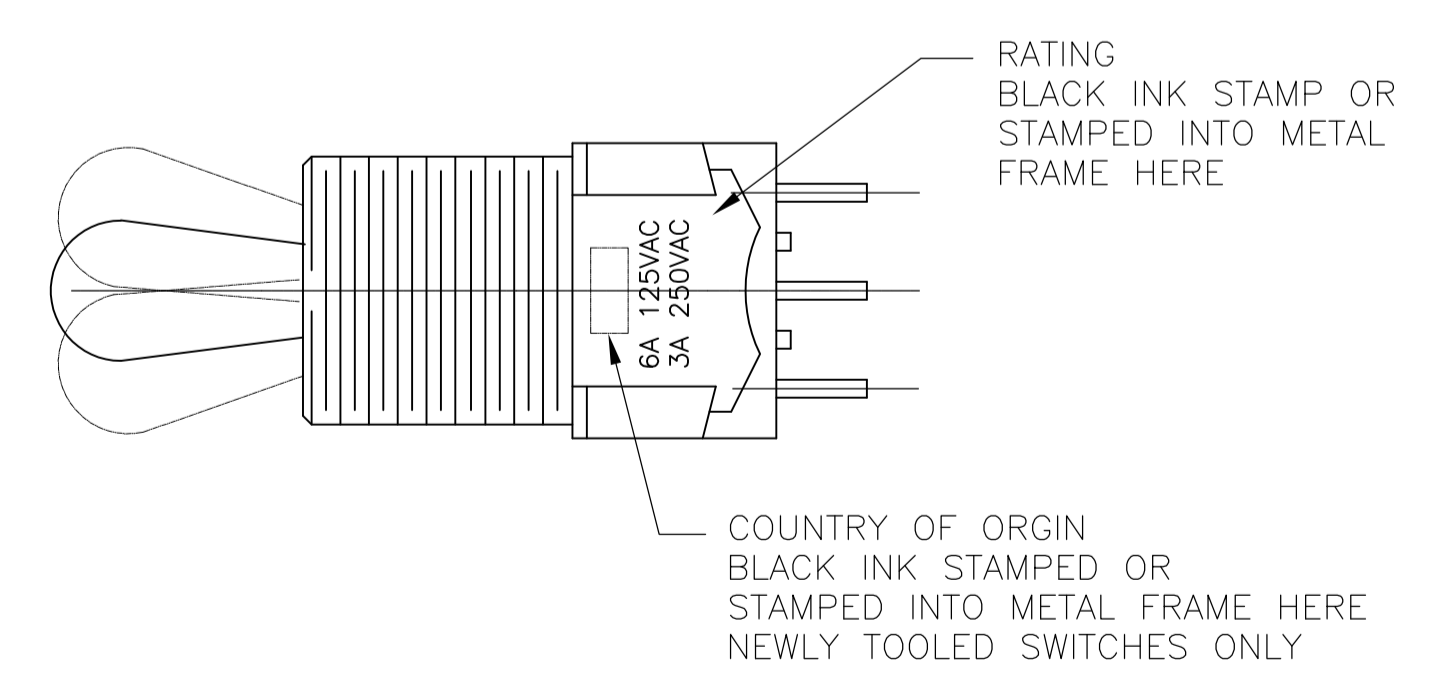

THIS DRAWING IS A CONTROLLED DOCUMENT.		DIN M. BINNER 29DEC03	Tyco Electronics Corporation Harrisburg, Pa 17105-3608													
DIMENSIONS: INCHES		CHK M. ZITTO 29DEC03	NAME M. ZITTO 29DEC03													
TOLERANCES UNLESS OTHERWISE SPECIFIED:		PRODUCT SPEC														
<table border="1"> <tr><td>0. PLC</td><td>± .005</td></tr> <tr><td>1. PLC</td><td>± .005</td></tr> <tr><td>2. PLC</td><td>± .005</td></tr> <tr><td>3. PLC</td><td>± .005</td></tr> <tr><td>4. PLC</td><td>± .005</td></tr> <tr><td>ANGLES</td><td>± .005</td></tr> </table>		0. PLC	± .005	1. PLC	± .005	2. PLC	± .005	3. PLC	± .005	4. PLC	± .005	ANGLES	± .005	APPLICATION SPEC		
0. PLC	± .005															
1. PLC	± .005															
2. PLC	± .005															
3. PLC	± .005															
4. PLC	± .005															
ANGLES	± .005															
MATERIAL		WEIGHT		RESTRICTED TO												
FINISH		A1 00779 C=1-1437559-1		SCALE 3:1 SHEET 2 OF 3 REV D1												
CUSTOMER DRAWING		SCALE 3:1 SHEET 2 OF 3 REV D1														

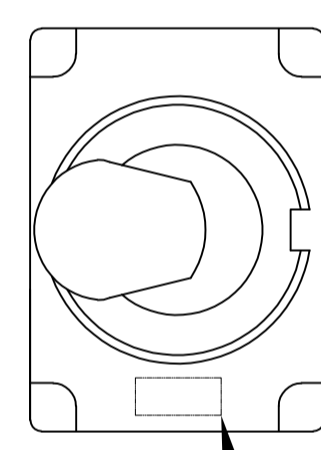
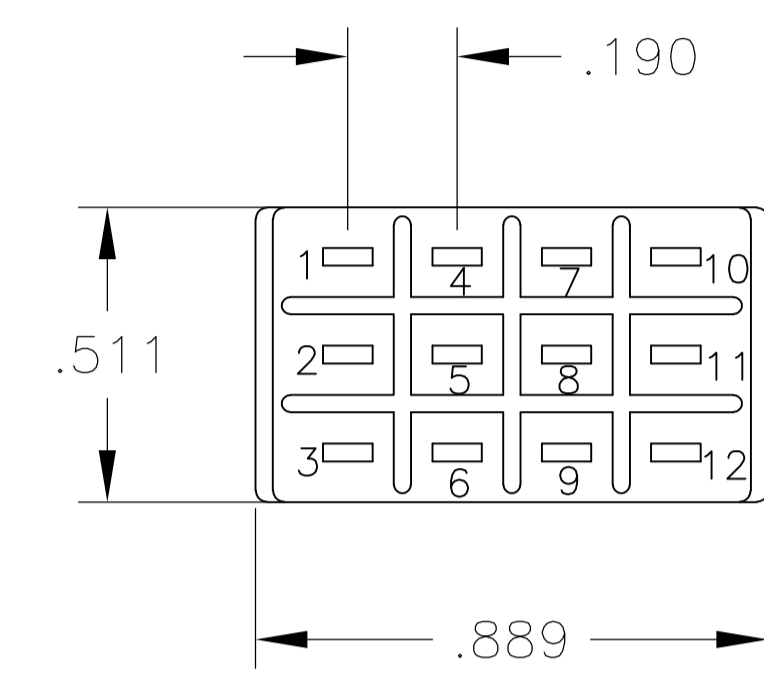
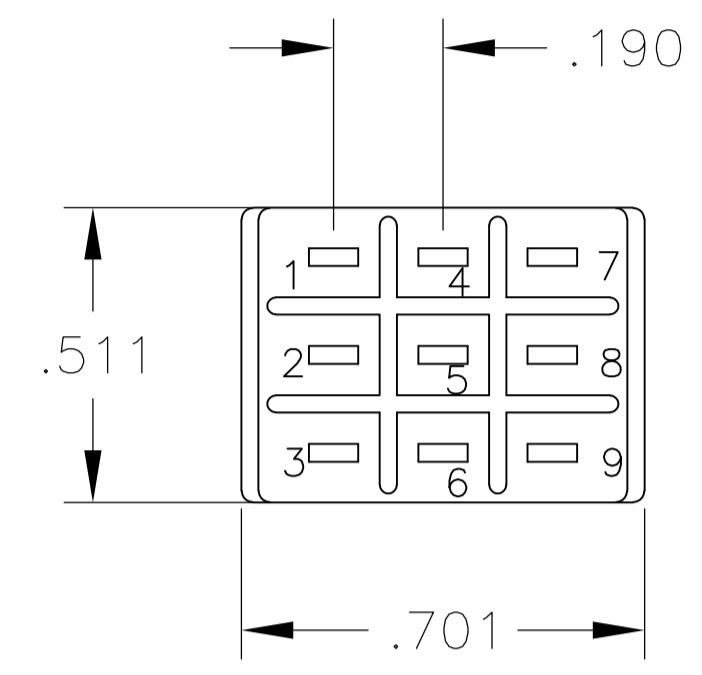
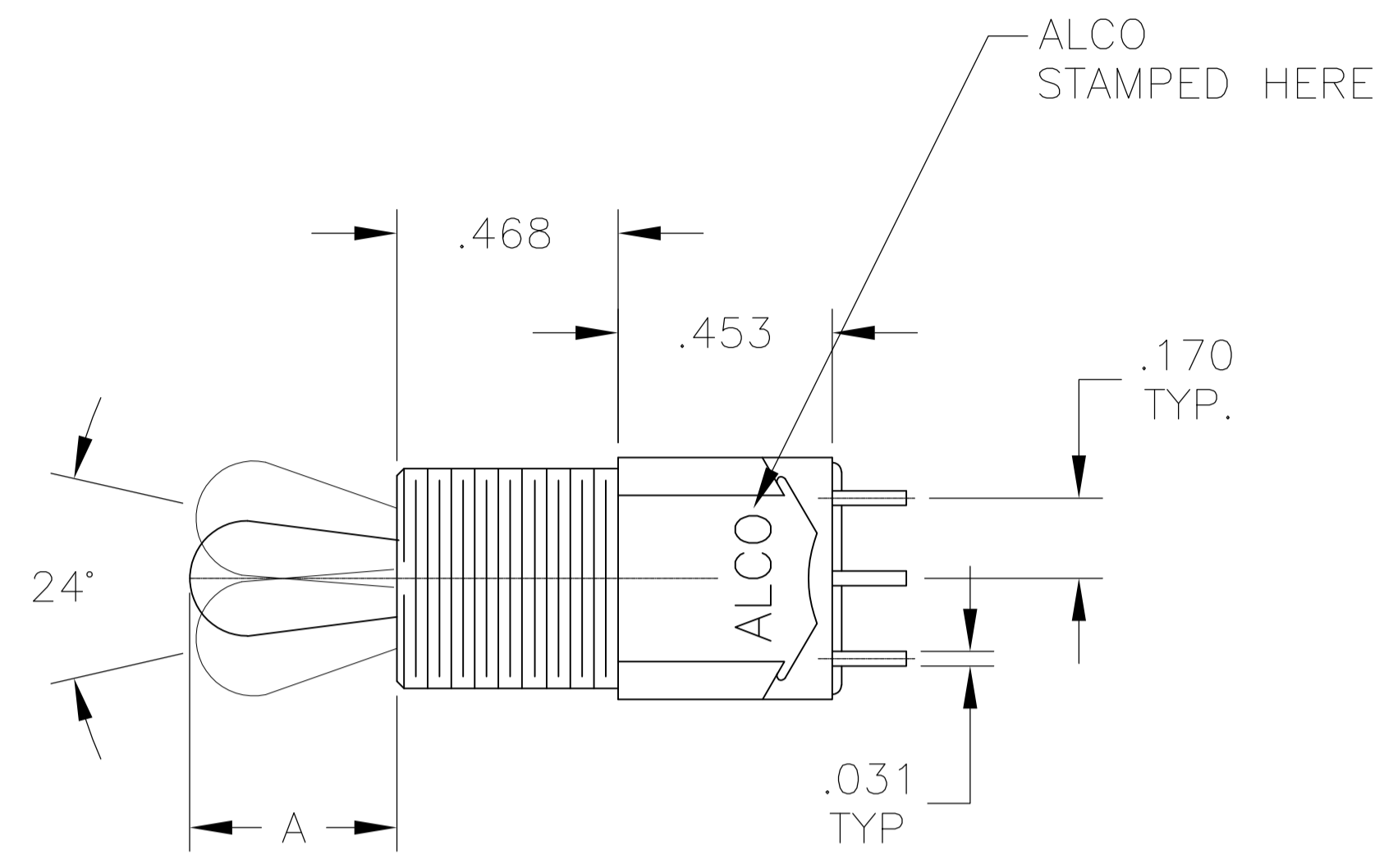

COUNTRY OF ORIGIN STAMPED HERE EXISTING SWITCHES ONLY

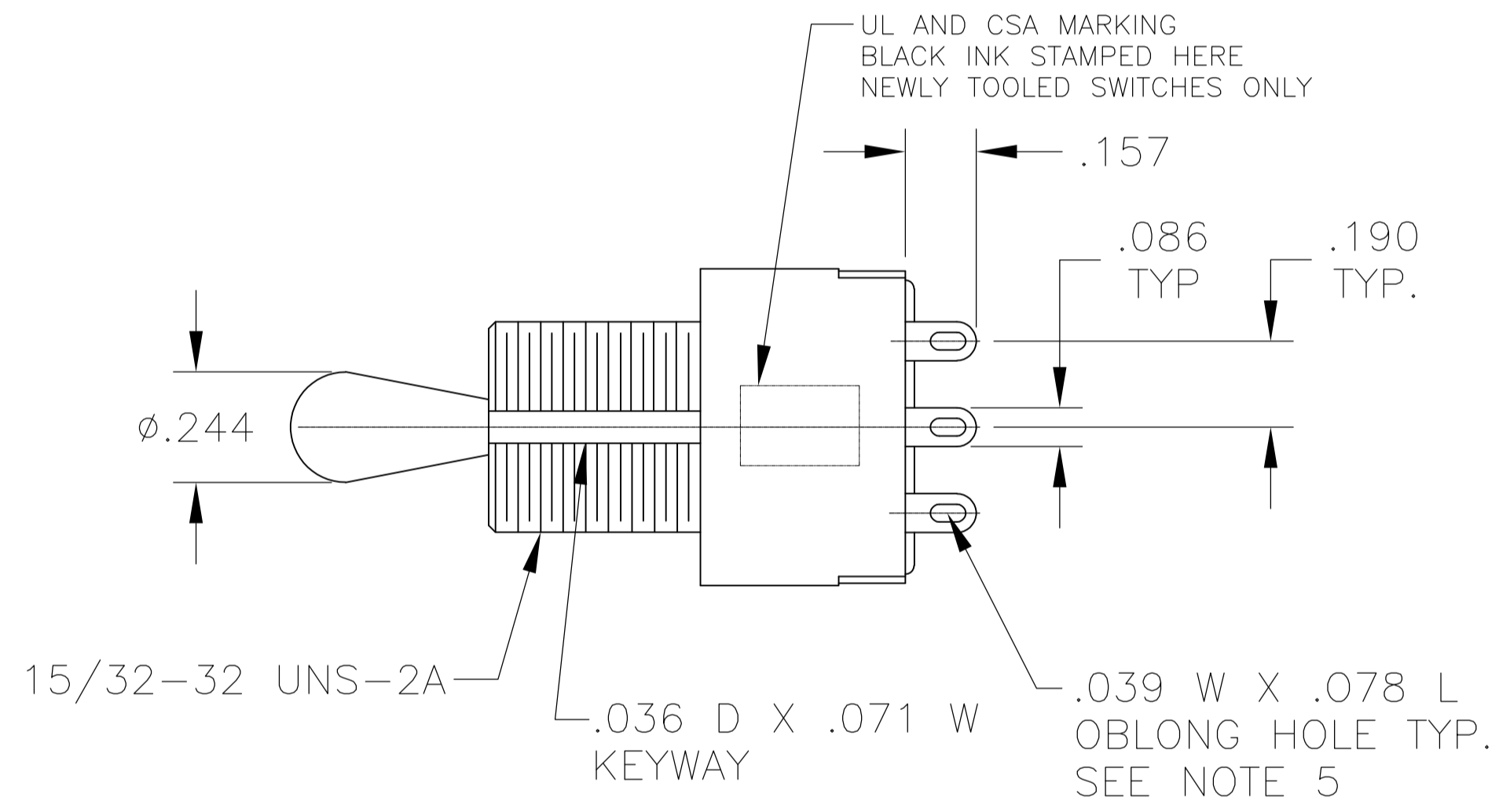

WIRE LUG TERMINAL

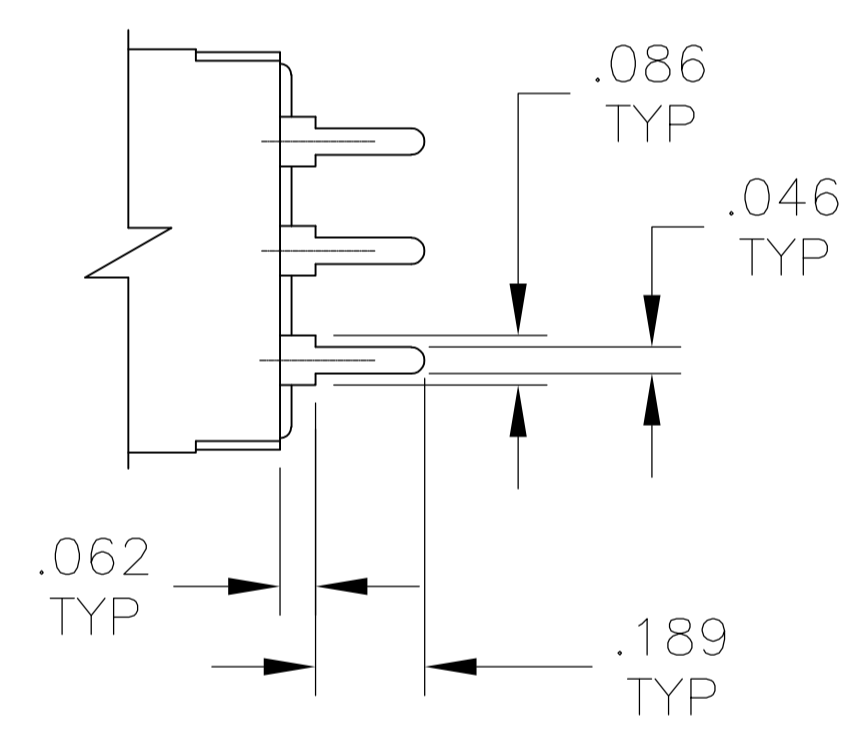

PC TERMINAL

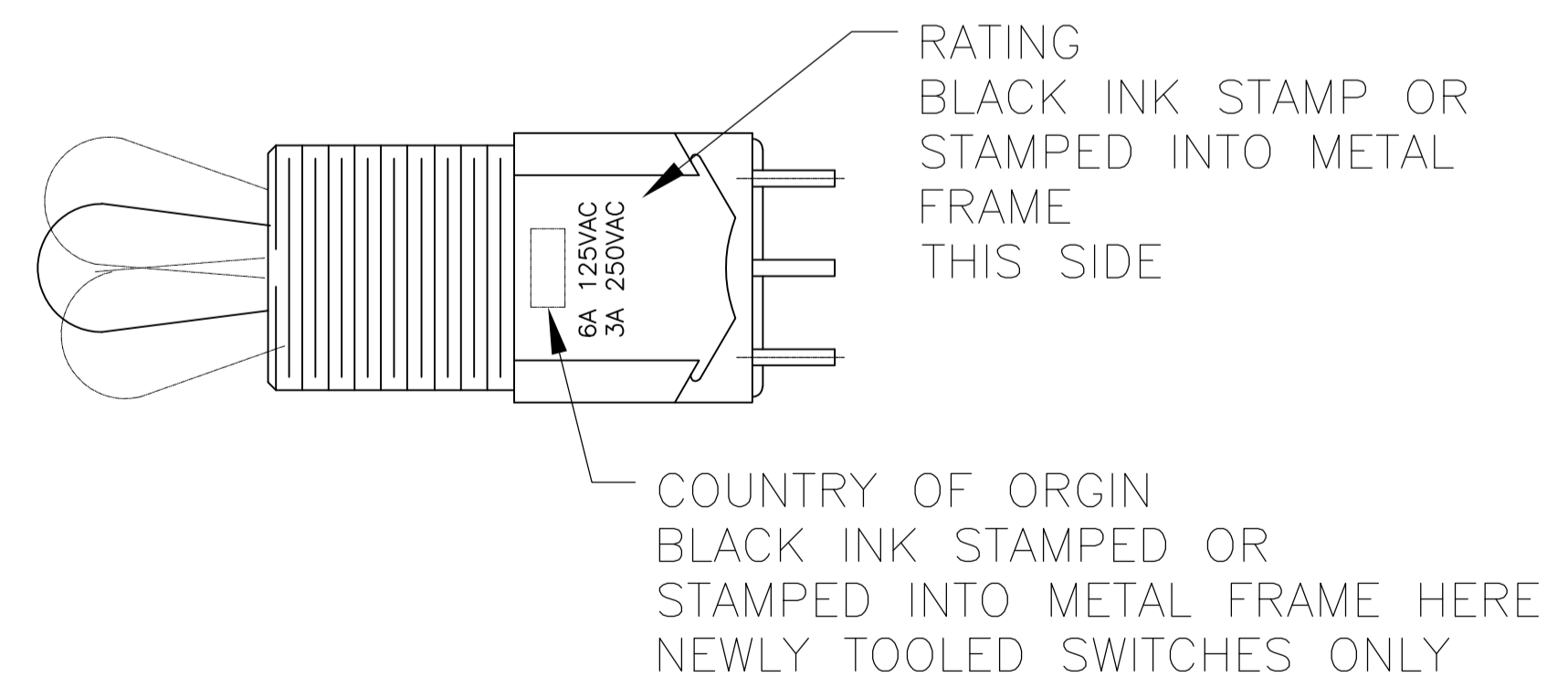

THIS DRAWING IS A CONTROLLED DOCUMENT.		DIN M. BINNER 29DEC03	Tyco Electronics Corporation Harrisburg, Pa 17105-3608
DIMENSIONS: INCHES		CHK M. ZITTO 29DEC03	
TOLERANCES UNLESS OTHERWISE SPECIFIED:		APP'D M. ZITTO 29DEC03	NAME
0. PLC ± .005	1. PLC ± .005	TOGGLE SWITCH, MTG SERIES VERTICAL MOUNT	
2. PLC ± .005	3. PLC ± .005	APPLICATION SPEC	
4. PLC ± .005	ANGLES ± .005	SIZE CAGE CODE DRAWING NO. RESTRICTED TO	
MATERIAL	FINISH	A1 00779 C=1-1437559-1	
CUSTOMER DRAWING		SCALE 3:1	SHEET 3 OF 3 REV D1