

THIS DRAWING IS UNPUBLISHED. RELEASED FOR PUBLICATION  
 © COPYRIGHT - By - ALL RIGHTS RESERVED.

\*AMPPOWER is a trademark

| LOC |     | DIST        |  | REVISIONS             |          |      |    |
|-----|-----|-------------|--|-----------------------|----------|------|----|
| P   | LTR | DESCRIPTION |  | DATE                  | DWN      | APVD |    |
| GP  | 00  | F           |  | REV PER ECO-12-000102 | 9JAN2012 | RG   | DY |

1. CABLE LENGTH TOLERANCE ON 0-150 INCH LONG CABLES = +0.2% -0% OF TOTAL CABLE LENGTH WITH A MINIMUM TOLERANCE OF +6.4 [.25] 0 [0]. CABLE LENGTH TOLERANCE ON CABLES OVER 150 INCHES LONG = + 1% -0% OF TOTAL CABLE LENGTH.
2. LABEL APPROXIMATELY WHERE SHOWN.
3. BECAUSE OF SHIPPING CONSTRAINTS, REFOLDING/SHAPING OF CABLE ASSEMBLIES MAY BE REQUIRED BY CUSTOMER BEFORE INSTALLATION.
4. PRODUCT AND PROCESSING MUST MEET REQUIREMENTS OF TYCO ELECTRONICS STANDARD 230-702.
5. OBSOLETE PARTS: OBSOLETE CIS STREAMLINING PER D.RENAUD/D.SINISI

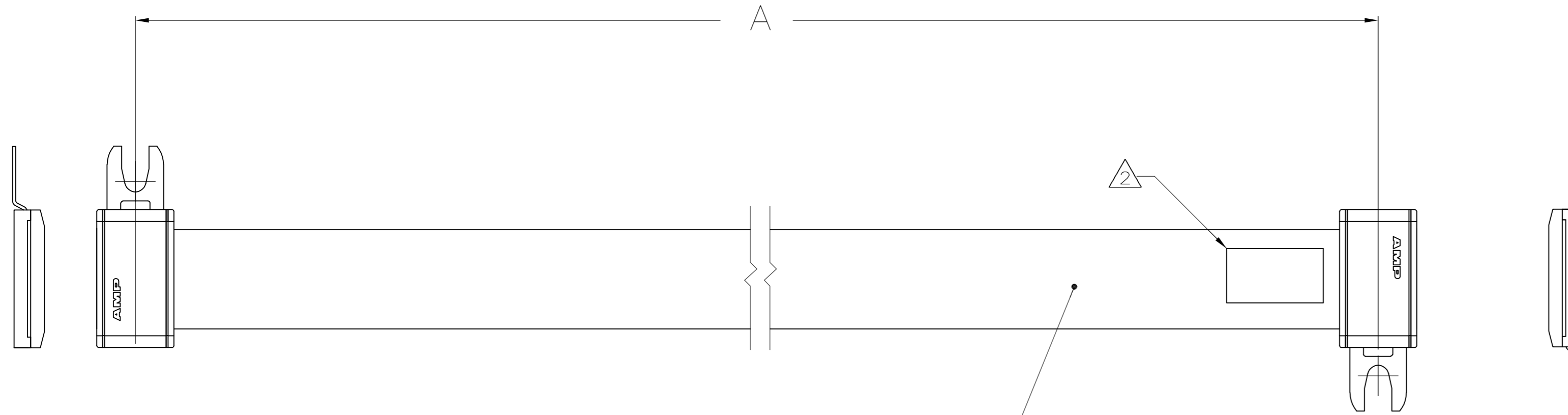

2 - 0.50[.020] THK SINGLE CONDUCTOR CABLES

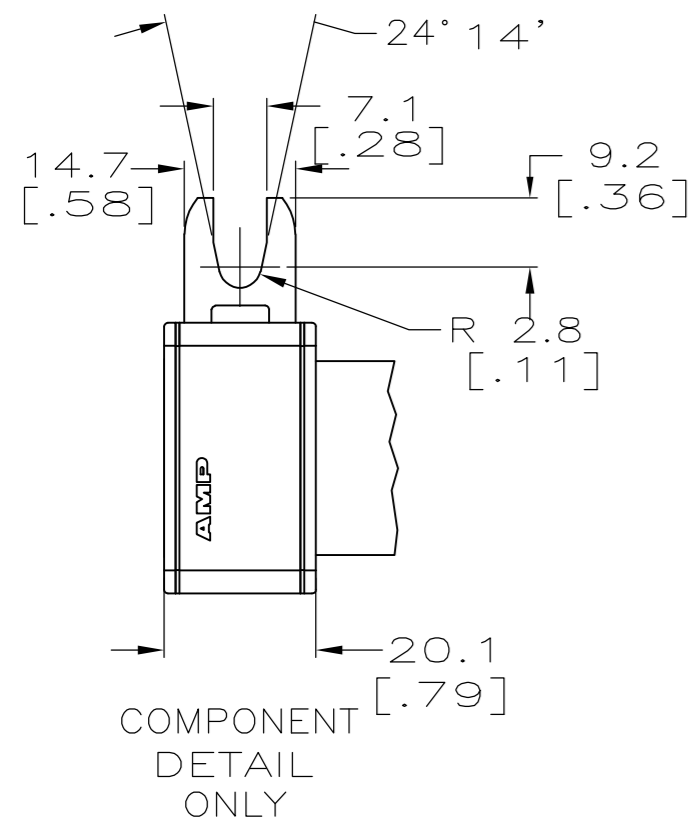

|          |                         |       |                     |             |
|----------|-------------------------|-------|---------------------|-------------|
|          | 1778.0 [70.0]           | SOLID | 0.50 [.020]         | 1-766109-0  |
|          | 2108.2 [83.0]           | SOLID | 0.50 [.020]         | 766109-9    |
|          | 1136.65 [44.75]         | SOLID | 0.50 [.020]         | 766109-8    |
| OBSOLETE | 1384.30 [54.50]         | SOLID | 0.50 [.020]         | 766109-7    |
|          | 1714.50 [67.50]         | SOLID | 0.50 [.020]         | 766109-6    |
|          | 2051.05 [80.75]         | SOLID | 0.50 [.020]         | 766109-5    |
| OBSOLETE | 755.7 [29.75]           | SOLID | 0.50 [.020]         | 766109-4    |
|          | 1574.8 [62.00]          | SOLID | 0.50 [.020]         | 766109-3    |
| OBSOLETE | 1765.3 [69.50]          | SOLID | 0.50 [.020]         | 766109-2    |
| OBSOLETE | 2032 [80.00]            | SOLID | 0.50 [.020]         | 766109-1    |
|          | CABLE ASSY REF LENGTH A | STYLE | CONDUCTOR THICKNESS | PART NUMBER |

|   |        |                  |             |          |            |                            |              |            |
|---|--------|------------------|-------------|----------|------------|----------------------------|--------------|------------|
| THIS DRAWING IS A CONTROLLED DOCUMENT.  |        | DWN              | D.A. BABOW  | 09-22-95 |            | TE Connectivity            |              |            |
| DIMENSIONS: mm [INCHES]   |        | CHK              | D.E. PETRIE | 09-22-95 |            | NAME                       |              |            |
| TOLERANCES UNLESS OTHERWISE SPECIFIED:  |        | APVD             | J.E. LUCIUS | 09-22-95 |            | CABLE ASSEMBLY, WAVE CRIMP |              |            |
| 0 PLC ± -<br>1 PLC ± 0.5 [.02]<br>2 PLC ± 0.25 [.010]<br>3 PLC ± -<br>4 PLC ± -<br>ANGLES ± - |        | PRODUCT SPEC     | -           |          |            | SIZE                       | CAGE CODE    | DRAWING NO |
| MATERIAL  | FINISH | APPLICATION SPEC | 114-49005   |          | A2         | 00779                      | C=766109     |            |
|   |        | WEIGHT           | -           |          | SCALE FULL |                            | SHEET 1 OF 1 |            |
|   |        | CUSTOMER DRAWING |             | REV      | F          |                            |              |            |