

MGBBT-00296-P	REV	
3-1879385-6	BA	

Product Description **XFMR EP13 SMD, ROHS MGBBT-00114**
Previously MGBBT-00296

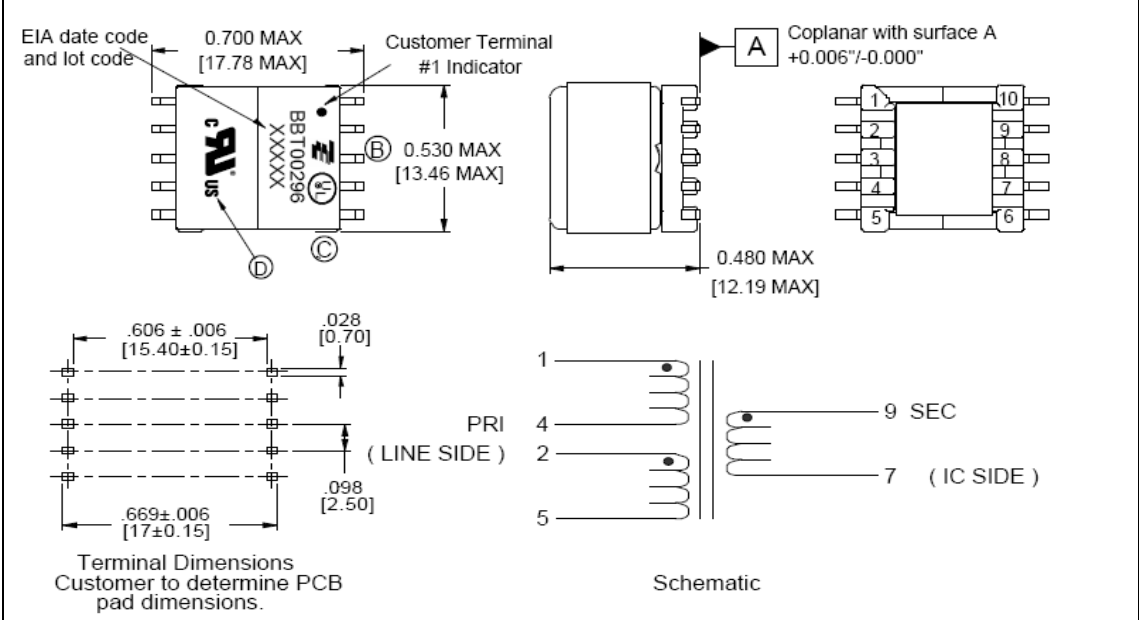

Primary Units are in inches millimetres in brackets

Electrical Specifications at +20°C unless noted otherwise

Test	Limits	Unit	Tol.	Notes
Inductance	3.00	mH	±10%	1-5 tie(2+4), 10kHz, 100mVAC, Ls.
Leakage Inductance	29.0	µH	Max.	1-5 tie(2+4, 9+7), 100kHz, 100mVAC,Ls.
DC Resistance	0.660	Ω	Max.	Pins 9 - 7
DC Resistance	3.30	Ω	Max.	Pins 1 - 5 tie(2 + 4)
Turns Ratio	4.5 : 1.00	--	±1%	(1-5) : (9-7) tie(2+4), 10KHz, 100mVAC
Dielectric	1,875	VAC	500µA	1-9 tie(2+4), 1 second test, 500uA maximum
Interwinding Capacitance	75.0	pF	Max.	1-9 tie(1+2+4+5, 7+9), 100kHz, 100mVAC,Cs.
Total Harmonic Distortion	-84.0	dB	Max.	10kHz, 4.0Vrms [11.31 Vp-p], Line : IC
Total Harmonic Distortion	-76.0	dB	Max.	3k (2nd Harmonic)Hz, 1.0Vrms [2.83 Vp-p], Line : IC
Total Harmonic Distortion	-84.0	dB	Max.	3k (3rd Harmonic)Hz, 1.0Vrms [2.83 Vp-p], Line : IC
Longitudinal Balance (ITU)	55.0	dB	Min.	5kHz - 400kHz.

Terminal Plating is Hot-dipped SnAgCu over Ni
260°C Maximum wave solder temperature per J-STD-020
Operating Temperature range -40°C to +85°C



Meets requirements of IEC60950 for basic insulation, 250V working voltage
The information contained in this drawing is the sole property of Tyco Electronics. Any reproduction or use without the written permission of Tyco Electronics is prohibited.

Specifications subject to change without notice. For latest revision visit <http://www.tycoelectronics.com>
Page 1 of 1 Date 20/01/09