

Figure 1

1. INTRODUCTION

Seating Tool 224441-1 and Support Anvil 224442-1 are used to seat UPM Connectors 223961-1 and 223962-1. See Figure 1. The connectors contain ACTION PIN contacts to allow solderless pc board installation.

NOTE



All numerical values in this instruction sheet are in metric units [with U.S. customary units in brackets]. Dimensions are in millimeters [and inches]. Figures are not drawn to scale.

Read these instructions and understand them before using the seating tool and support anvil.

Reasons for reissue of this instruction sheet are provided in Section 7, REVISION SUMMARY.

2. DESCRIPTION

The seating tool and support anvil are each one-piece aluminum. The support anvil is positioned into a pc board support fixture to support the pc board. During seating, the seating tool covers the connector and presses on the top surface of the connector when the applicator ram applies force to the seating tool.

3. REQUIREMENTS

3.1. PC Board Support Fixture

A pc board support must be used to provide proper support for the pc board and alignment of the tool to the contacts and to protect the pc board and contacts from damage. PC Board Support Fixture 679980-[] is recommended for use with this seating tool and

support anvil. For proper selection and usage information, refer to instruction sheet 408-4038.



As an alternative, design a pc board support fixture using the recommendations in 408-6927.

3.2. Application Tooling

Power for seating must be provided by a machine capable of supplying a downward force of 89 Newtons (N) [20 lb] per contact. Contact TOOLING ASSISTANCE CENTER at the number at the bottom of page 1 for recommendations.

4. SEATING

1. Set seating height to the dimension shown in Figure 2 (applicator *shut height* will equal the seating height PLUS the combined thicknesses of the pc board, support anvil, and pc board support).
2. Position the support anvil, grooved side up, into the pc board support fixture and center it under the applicator ram of the application tooling. Position the pc board over the support anvil.
3. Position the connector into pc board so that contacts are properly aligned to the pc board and support anvil. See Figure 2.
4. Insert connector into pc board until ACTION PIN sections of the contacts are resting securely on, but have not fully entered, the pc board.

5. Position the seating tool onto the connector.
6. Center seating tool and connector under the applicator ram of the power source; slowly lower ram until it just meets the seating tool. Verify the alignment of the board support, pc board, connector, seating tool, and support anvil.



Damage to the pc board, seating tool, or connector may occur if the seating height is improperly set, if pc board is not properly positioned over the support anvil, or if the seating tool is not properly seated on the connector before cycling the applicator ram.

7. Cycle applicator ram according to instructions for the power source. Check assembly for proper seating using the requirements in Figure 2.
8. Remove pc board with seated connector, or reposition board and board support for seating additional connectors.

5. MAINTENANCE AND INSPECTION

The seating tool and support anvil are inspected before shipment. It is recommended that the tool and support anvil be inspected immediately upon its arrival at your facility to ensure that it has not been damaged during shipment. Refer to Figure 3 for dimensions.

Regular inspections should be performed by quality control personnel. A record of scheduled inspections should remain with the seating tool and support anvil

View After Seating

Note: Not to Scale

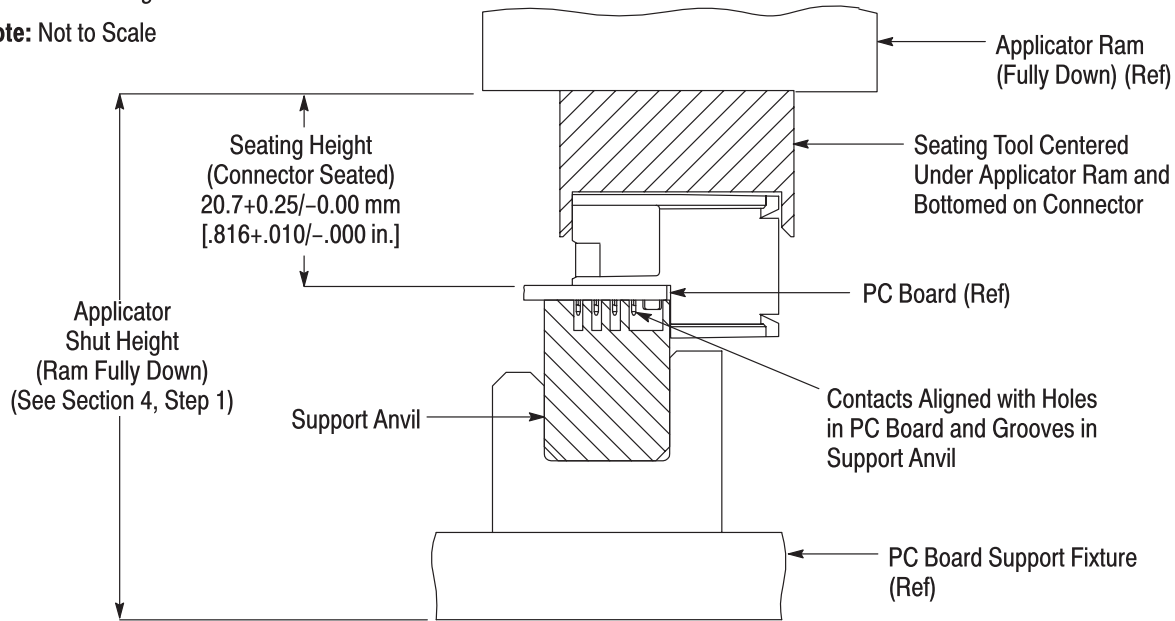

Figure 2

or be supplied to responsible personnel. The inspection frequency should be based on the amount of use, working conditions, operator training and skill, and established company standards.

It is recommended that each operator be made aware of, and responsible for, the following steps of daily maintenance.

1. Remove dust, moisture, and other contaminants with a clean, soft brush, or lint-free cloth. DO NOT use objects that could damage the seating tool or support anvil.
2. When the seating tool and support anvil are not in use, store them in a clean, dry area.

6. REPLACEMENT AND REPAIR

Order seating tools and support anvils through your representative, or call 1-800-526-5142, or send a

facsimile of your purchase order to 717-986-7605, or write to:

CUSTOMER SERVICE (038-035)
TYCO ELECTRONICS CORPORATION
PO BOX 3608
HARRISBURG PA 17105-3608

For customer repair service, call 1-800-526-5136.

7. REVISION SUMMARY

Revisions to this instruction sheet include:

- Updated document to corporate requirements
- Removed obsolete "H" Frame Assembly 803880-6 and SM-3 Frame Assembly 814700-2
- Replaced customer repair address with customer repair phone number

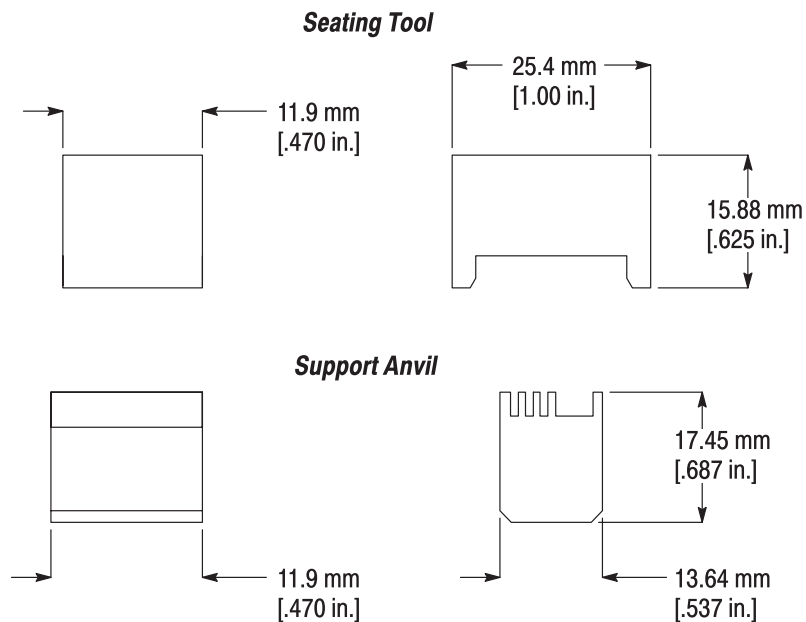

Figure 3