Sealed EFI ECU 0.64/2.3II I/O Connector

1. Scope:

1.1 Contents

This specification covers the requirements for product performance, test methods and quality assurance provisions of Sealed 0.64/2.3 II I/O Connector.

Applicable product description and part numbers are as shown in Appendix 1.

2. Applicable Documents:

The following documents form a part of this specification to the extent specified herein. In the event of conflict between the requirements of this specification and the product drawing, the product drawing shall take precedence. In the event of conflict between the requirements of this specification and the referenced documents, this specification shall take precedence.

2.1 TE Specifications

- A. 109-5000 : Test Specification, General Requirements for Test Methods
- B. 114-5336 : Application Specification: Crimping of Sealed 0.64 Receptacle Contact
- C. 501-5723 : Test Report
- D.411-78084 : Instruction Sheet

2.2 Commercial Standards and Specifications

- A. JASO D605 Multi-pole Connector for Automobiles
- B. JASO D7101 Test Methods for Plastic Molded Parts
- C. JIS C3406 Low Voltage Wires and Cables for Automobiles
- D. JIS D0203 Method of Moisture, Rain and Spray Test for Automobile Parts
- E. JIS D0204 Method of High and Low Temperature Test for Automobile Parts
- F. JIS D1601 Vibration Testing Method for Automobile Parts

2.3 Other Specifications

See instruction sheet of each terminal maker about application specification of Sealed 2.3 II receptacle.

3. Requirements

3.1 Design and Construction

Product shall be of the design, construction and physical dimensions specified on the applicable product drawing.

3.2 Materials

A. Terminals

Description	Material	Finish
0.64Tab (Male)	Brass	Selective Gold plating over Ni under plating. Selective Tin plating over Ni under plating
2.3Tab (Male)	Brass	Selective Tin plating over Ni under plating
0.64Receptacle (Female)	Copper Alloy	Selective Gold plating over Ni under plating. Pre-Tinned
2.3 II Receptacle (Female)	※	※

※If needed, please make reference to Terminal producer.

B. Housing

No.	Description	Material
1	Plug Housing	PBT
2	Front Cavity	PBT
3	Retainer	PBT
4	Seal Ring	Silicone
5	Slide	PBT
6	Lever	PBT
7	Cap Housing	PBT
8	Tine Plate	PBT
9	Wire Cover	PBT
10	Clip	PBT

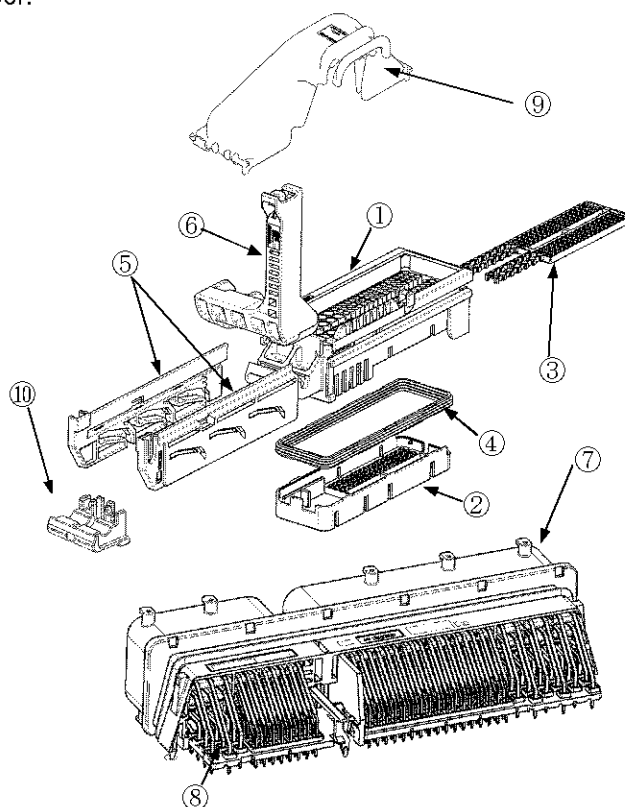

C. Wire

Terminal type	Applicable wire range
0.64	0.22~0.5mm ²
2.3 II	0.3~2.0mm ²

※Application Specification of each terminal indicates the details of wires.

3.3 Ratings

- A. Voltage rating : 12V DC
- B. Temperature rating : -40°C ~ 140°C

3.4 Performance Requirements and Test Descriptions

The product shall be designed to meet the electrical, mechanical and environmental performance requirements specified in Fig.1. All tests shall be performed in the room temperature, unless otherwise specified.

3.5 Test Requirements and Procedures Summary

Para.	Test Items	Requirements	Procedures
3.5.1	Confirmation of Product	Meets requirements of product drawing and TE Specification.	Visually , dimensionally and functionally inspected per applicable quality inspection plan
Electrical Requirements			
3.5.2	Termination Resistance (Low Level)	0.64 8mΩ Max. (Initial) 16mΩ Max. (Final)	Subject mated contacts assembled in housing to 20 mV Max. open circuit at 10 mA. See Fig. 3 TE Spec. 109-5311-1
		2.3 II 3mΩ Max. (Initial) 10mΩ Max. (Final)	
3.5.3	Termination Resistance (Specified Current)	0.64 8mV/A Max. (Initial) 16mV/A Max. (Final)	Subject mated contacts assembled in housing to 12 V Max. short circuit at 1A. Fig.3 TE Spec. 109-5311-2
		2.3 II 3mV/A Max. (Initial) 10 mV/A Max. (Final)	
3.5.4	Insulation Resistance	100MΩ Min.	Impressed voltage 500V DC Mated connector. Fig.4 TE Spec. 109-5302
3.5.5	Dielectric Withstanding Voltage	No creeping discharge or flashover shall occur	Impressed voltage 1kV AC for 1 min. Mated connector. Fig.4 TE Spec. 109-5301
3.5.6	Current Leakage	50 μ A Max.	Impressed voltage 14VDC Fig.5 TE Spec. 109-5312
3.5.7	Temperature Rise	60°C Max.	Measure temperature rising at wire crimped by applied current to all positions. 0.64:2.2A / 2.3 II :3.8A TE Spec. 109-5310
3.5.8	Over Current Loading	No ignition is allowed during the test.	Apply the current to only one position. Applied Current : Fig. 6
Physical Requirements			
3.5.9	Vibration (High Frequency)	No electrical discontinuity greater than 1 μ sec. shall occur. Satisfy requirements of test item on the "3.6 sequence".	Vibration Frequency and Acceleration: 20~200Hz 88m/s ² (continuous) Sweep time:3min/both way Direction: X, Y, Z Duration: 3hours each Mounting:Fig.7

Fig.1 (To be continued)

Para.	Test Items	Requirements	Procedures		
3.5.10	Shock	No electrical discontinuity greater than 1 μ sec. shall occur.	Acceleration: 980m/s ² Duration:6msec Waveform : Half sine wave Number of Drops: 3 drops each Directions of X,-X, Y,-Y,Z and -Z axes, totally 18 drops Mounting:Fig.7 TE Spec. 109-5208		
3.5.11	Lever Operation force	50N Max. (Mating) 70N Max. (Unmating)	Mating male connector and female connector with all terminals loaded. Measured operation force for rotating lever from position A to B and from B to A in Fig.8.		
3.5.12	Connector Locking Strength	100N Min.	Measured axial tensile strength with pulling one of mated connectors. Operation speed: 100mm/min. TE Spec.109-5210		
3.5.13	Terminal Insertion Force into Plug housing	10N Max. (per 1 terminal)	Measured insertion force of terminal fitting into housing. TE Spec. 109-5211		
3.5.14	Terminal Retention Force (at final locked position)	100N Min.	Measure contact retention force with secondary lock set it effect. Operation Speed: 100mm/min. TE Spec. 109-5212		
3.5.15	Crimp tensile strength For 0.64 terminal	Wire size	Tensile Strength【N】	Apply an axial pull-off load to crimped wire of contact secured on the tester. Operation speed: 100mm/min. TE spec. 109-5205 Condition B ※including Insulation barrel crimp	
		0.3mm ²	Initial		55 Min.※
			Final		40 Min.※
		0.5 mm ²	Initial		90 Min.
Final	70 Min.				
3.5.16	Retention Force of Post	0.64	25N Min.	Measure the retention force between housing and tab contact. Operation direction: P. C. Board side Operation speed: 100mm/min.	
		2.3 II	30N Min.		
3.5.17	Resistance of “Kojiri”	Satisfy requirements of test item on the “3.6 sequence”.	Repeated mating-unmating by hand in up-down and right-left directions for 10 cycles. TE Spec. 109-5215		
3.5.18	Solderability	Wet Solder Coverage: 95 % Min.	Solder Temperature :260±5°C Immersion Duration :10±1sec. Flux: ALPHA100 TE Spec. 109-5204		
3.5.19	Handling Ergonomics	No abnormalities allowed in manual mating/unmating handling.	Manually operated.		

Fig.1 (To be continued)

Para.	Test Items	Requirements		Procedures
3.5.20	Watertight Sealing	Wire seal area		200kPa Min.
		Seal ring area Rubber plug	Initial	50kPa Min.
			Final	30kPa Min.
				Blow compressed air into mated connectors through a small hole. In this test, wire ends are sealed with solder and adhesive masking. Immerse connectors in water in 10cm depth. Check air leakage at 9.8kPa air for 30 sec. If the leakage from them isn't checked, increase pressure at a rate of 9.8kPa each time until air leakage takes place.
3.5.21	Retention Force of Wire Cover	100N Min.		The pull wire cover comes off from the electric wire while installed on the female connector is measured.
3.5.22	Locking Strength of lever point	50N Min.		The lever is pulled without pushing the release button from the state of the lever lock, and the retentivity of the lever lock is measured.
3.5.23	Clip Insertion Force into Plug housing	40N Max.		Measured insertion force of clip fitting into housing.
3.5.24	Retention Force of Clip	70N Min.		The load from which a clip separates from the state which attached the clip to the female connector is measured.
3.5.25	Irregular detection force	100N Min.		The clip is installed on the female connector, when the lever is rotated in the mating direction with the boss hung on the slider is measured as shown in Fig.11.
Environmental Requirements				
3.5.26	Heat Aging (Temperature Life)	Satisfy requirements of test item on the "3.6 sequence".		140°C、120Hours TE Spec. 109-5104
3.5.27	Resistance to Cold	Satisfy requirements of test item on the "3.6 sequence".		-40°C、120Hours TE Spec. 109-5108
3.5.28	Thermal Shock	Satisfy requirements of test item on the "3.6 sequence".		-40°C/30min., 100°C/30min. Making this a cycle, repeated 1000 cycles. Monitor fluctuation of electrical resistance at 10mA current loaded during the test. TE Spec. 109-5103
3.5.29	Humidity-Temperature Cycling	Satisfy requirements of test item on the "3.6 sequence".		Condition : Fig. 9 Making this condition a cycle, repeated 10 cycles. Monitor fluctuation of electrical resistance at 10mA current loaded during the test. TE Spec. 109-5106
3.5.30	Salt Water Spray	Satisfy requirements of test item on the "3.6 sequence".		Spraying salt water on hanged mated connectors in closed chamber. Condition of salt water is 5±1 mass% at 35°C and specific gravity 1.0268~1.0413 and pH6.5~7.2 and Compressed air supplied 68.6~176.5kPa. And then, leave connectors at 80°C, 90~95%RH for 96 hours. Monitoring current leakage during test. TE Spec. 109-5101

Fig.1 (To be continued)

Para.	Test Items	Requirements	Procedures
3.5.31	Water Spray	Satisfy requirements of test item on the "3.6 sequence".	Hanged mated connectors in closed chamber and heated them at $100\pm 3^{\circ}\text{C}$ for 40min. And then spray with water of room temperature immediately. Test condition is JIS D 0203 S1. Monitoring current leakage during test. TE Spec. 109-5109
3.5.32	Resistance to High Pressure Washing	Satisfy requirements of test item on the "3.6 sequence".	Mounting mated connectors on the stage of chamber and heat them at $100\pm 3^{\circ}\text{C}$ for an hour. Spray 8MPa compressed water. The stage is rotated at $5\pm 1\text{REV}/\text{min}$.
3.5.33	Humidity (Steady State)	Satisfy requirements of test item on the "3.6 sequence".	85°C 、 $90\sim 95\% \text{RH}$ 96 時間 hour Monitoring current leakage during test. TE Spec. 109-5105
3.5.34	Dust Bombardment	Satisfy requirements of test item on the "3.6 sequence".	Subject JIS R 5210 cement blow of 1.5kg per 10 seconds in 15 minutes intervals for 8 cycles, with mating/unmating per 2 cycles. TE Spec. 109-5110
3.5.35	Industrial Gas (SO_2)	Satisfy requirements of test item on the "3.6 sequence".	Unmated connector SO_2 Gas: 25ppm, 75% R. H. 25°C , 96 hours TE Spec. 109-5107
3.5.36	Compound Environment Resistance	No electrical discontinuity greater than $1\ \mu\text{sec}$. shall occur. Satisfy requirements of test item on the "3.6 sequence".	Temperature: 120°C Vibration Frequency and Acceleration: $20\sim 200\text{Hz}$ $88\text{m}/\text{s}^2$ (continuous) Sweep time:3min/both way Direction: X, Y, Z Test Time: 300 hours Mounting: Fig.7 Current loaded: Fig.10 Monitor fluctuation of electrical resistance during test. After testing, check discontinuity based on Para. 3.5.9"Vibration" for an hour.
3.5.37	Resistance to Oil	Satisfy requirements of test item on the "3.6 sequence".	Test (1) Immerse mated connectors as the following procedure. Leave samples under room temperature for 24 hours after each immersion. ① Torque converter oil at $85\pm 2^{\circ}\text{C}$ ② Transmission oil ③ Engine oil ④ Crutch oil or Brake oil Testing after leaving samples under room temperature for 24 hours.

Fig.1 (To be continued)

Para.	Test Items	Requirements	Procedures
3.5.37	Resistance to Oil	Satisfy requirements of test item on the "3.6 sequence".	<p>Test (2) Immerse mated connectors in the following procedure. Leave samples under room temperature for 24 hours after each immersion.</p> <ul style="list-style-type: none"> ① Windshield washer liquid as concentration: 30%, at $50 \pm 2^{\circ}\text{C}$ ② Long life coolant at $118 \pm 5^{\circ}\text{C}$ <p>Testing after leaving samples under room temperature for 24 hours.</p> <hr/> <p>Test (3) Immerse mated connectors of other specimens in the following oil under room temperature for an hour.</p> <ul style="list-style-type: none"> • Gasoline • Gas oil • Battery liquid <p>Testing after leaving samples under room temperature for 24 hours.</p>

Fig.1 (End)

3.6 Product Qualification Test Sequence

Para	Test Item	Test Group																
		1	2	3	4	5	6	7	8	9	10	11	12	13	14	15	16	17
		Test Procedure ^(a)																
3.5.1	Confirmation of Product	1	1,3	1,3	1,3	1,3	1,3	1,4	1,4	1,3	1,4	1,3	1,3	1,3	1,3	1,3	1,3	1,3
3.5.2	Termination Resistance (Low level)	5	4	4		4	4	5			5	4	4	4		4	4	
3.5.3	Termination Resistance (Specified Current)	6	5	5		5	5	6			6	5	5	5		5	5	
3.5.4	Insulation Resistance	8					6	7	5	4	7							
3.5.5	Dielectric Withstanding Voltage	9					7	8	6		8							
3.5.6	Current Leakage							3	3		3							
3.5.7	Temperature Rise	7		6														6
3.5.8	Over Current Loading																2	
3.5.9	Vibration (High Frequency)													2				
3.5.10	Shock															2		
3.5.11	Lever Operation force (ON)	4																
	Lever Operation force (OFF)	11																
3.5.12	Connector Locking Strength	13		9		8	10				9							
3.5.13	Terminal Insertion Force	2																
3.5.14	Terminal Retention Force	14		10	5	9	11	9			10							
3.5.15	Crimp tensile strength	15		11		10							6					
3.5.16	Retention Force of Post	16																
3.5.17	Resistance of "Kojiri"		2															
3.5.18	Solderability	3																
3.5.19	Handling Ergonomics	12		8		7	9											
3.5.20	Watertight Sealing	10	6	7	4	6	8											4
3.5.21	Retention Force of Wire Cover	17																
3.5.22	Locking Strength of lever point	18																
3.5.23	Clip Insertion Force into Plug housing	19																
3.5.24	Retention Force of Clip	20																
3.5.25	Irregular detection force	21																
3.5.26	Heat Aging			2														
3.5.27	Resistance to Cold				2													
3.5.28	Thermal Shock					2												
3.5.29	Humidity-Temperature Cycling							2										
3.5.30	Salt Water Spray								2									
3.5.31	Water Spray									2								
3.5.32	Resistance to High Pressure Washing										2							
3.5.33	Humidity (Steady State)											2						
3.5.34	Dust Bombardment												2					
3.5.35	Industrial Gas (SO ₂)													2				
3.5.36	Compound Environment Resistance																	2
3.5.37	Resistance to Oil																	2

(a) Numbers indicate sequence in which tests are performed.

Fig.2

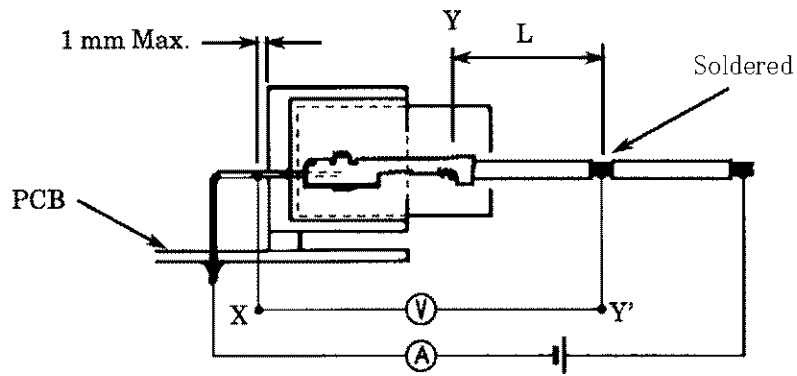

Deduct resistance of Y-Y' (wire "L") from X-Y'.

Fig.3

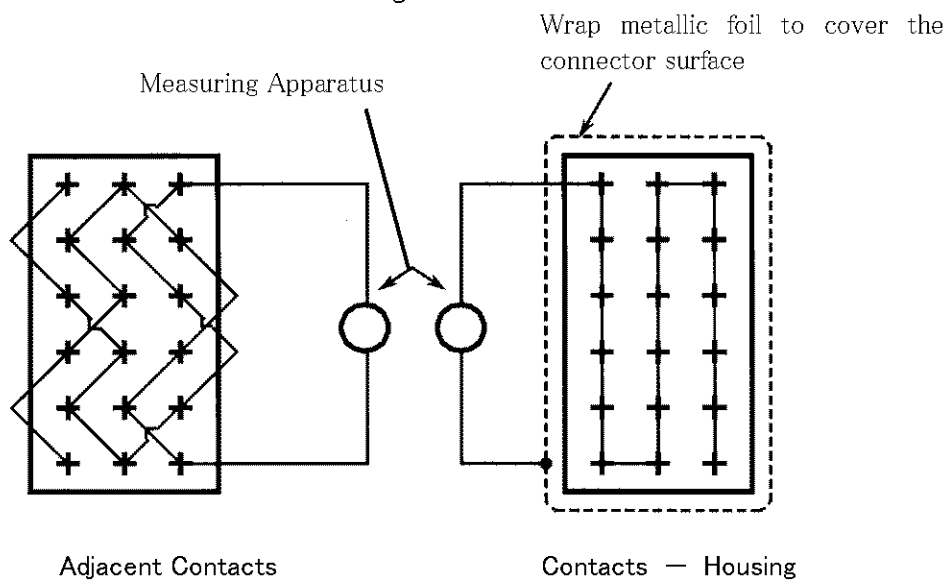

Fig.4

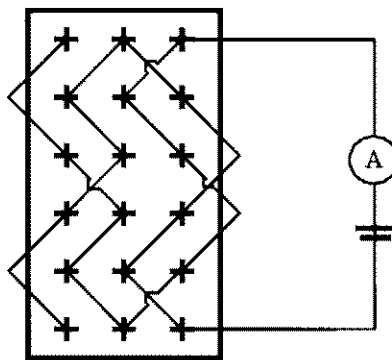

Fig. 5

Wire Size (mm ²)	Current Type	Test Current (A)	Duration
0.5	①	16.5	60 min.
	②	20.2	200 sec.
	③	22.5	5 sec.
	④	30.0	1 sec.
1.25	①	33.0	60 min.
	②	40.5	100 sec.
	③	45.0	10 sec.
	④	60.0	2 sec.

Fig.6

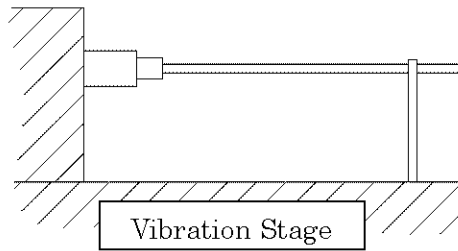

Fig.7

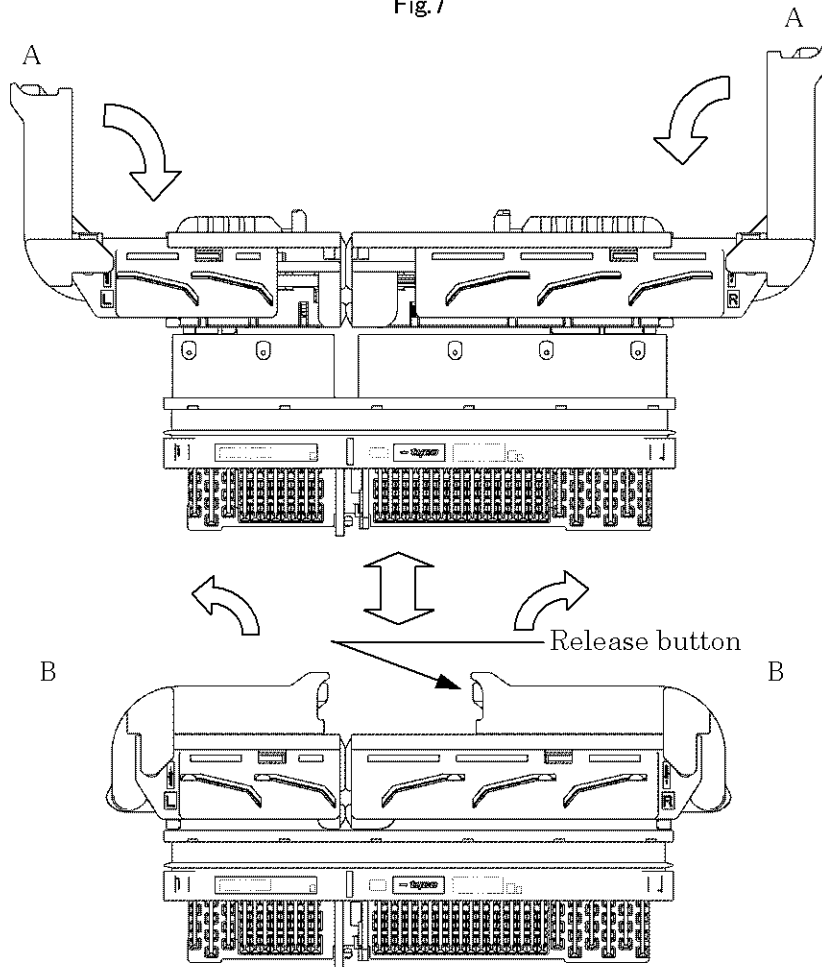

Fig.8

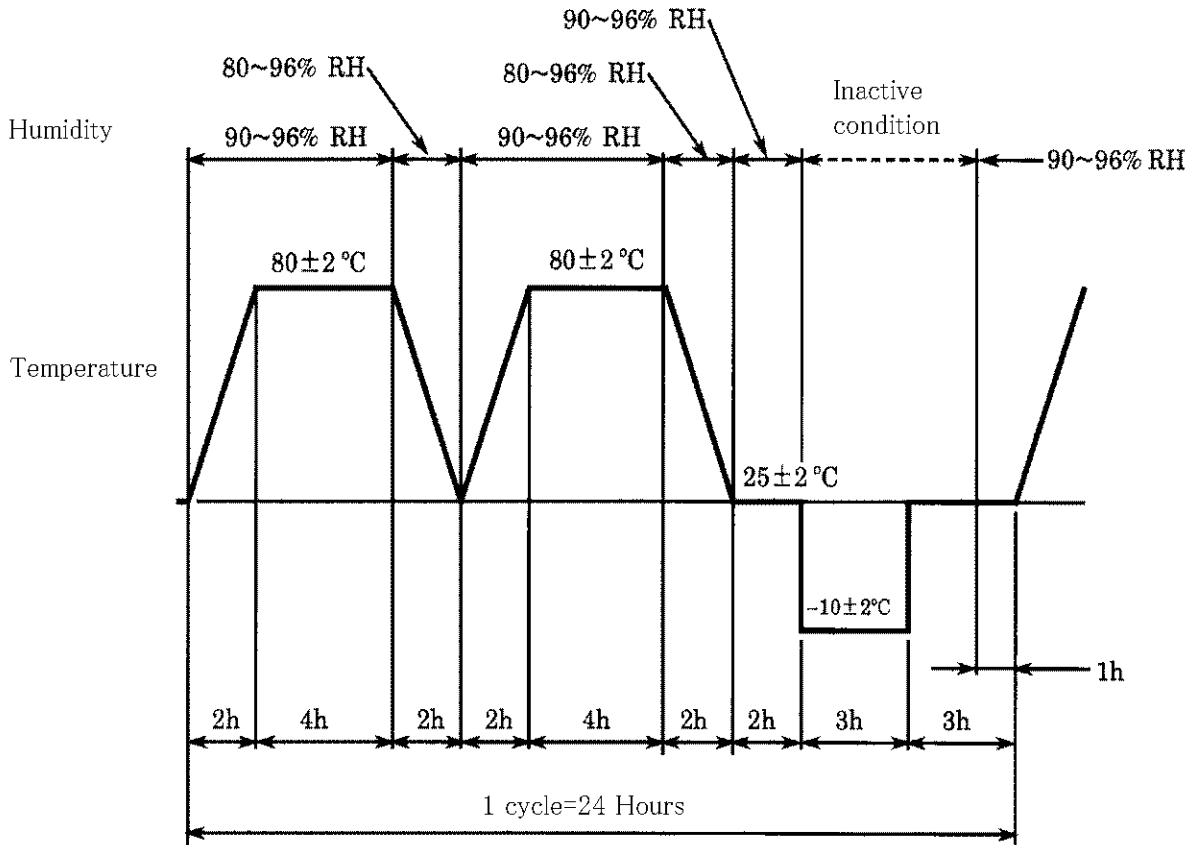

Fig.9

Terminal	Finish	Wire Size (mm ²)	Loading Current	Temperature Rise
0.64	Sn	0.5	1.2A	45min.ON, 15min.OFF 300cycles
	Au		10mA	
2.3	Sn	1.25	2.0A	

Fig.10

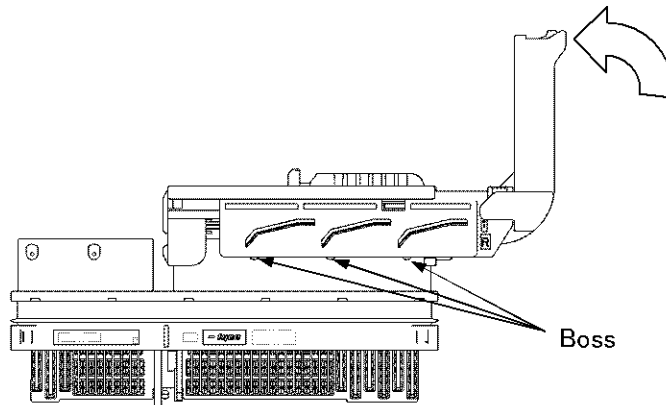

Fig.11

The applicable product descriptions and part numbers

Part Number★ ¹	Description
1612272	Sealed 0.64/2.3 II I/O Conn. 186Pos. Cap Housing Assembly (Male Connector)
1747536	Sealed 0.64/2.3 II I/O Conn. 186Pos. Cap Housing Assembly (Male Connector) Flange Type
1827028	Sealed 0.64/2.3 II I/O Conn. 186Pos. Cap Housing Assembly (Male Connector) THS Type
1717313	Sealed 0.64/2.3 II I/O Conn. 149Pos. Cap Housing Assembly (Male Connector)
1612275	Sealed 0.64/2.3 II I/O Conn. 126Pos. Plug Housing Assembly (Female Connector)
	Sealed 0.64/2.3 II I/O Conn. 89Pos. Plug Housing Assembly (Female Connector)
1747137	Sealed 0.64/2.3 II I/O Conn. 126Pos. Plug Housing Assembly Reverse (Female Connector)
	Sealed 0.64/2.3 II I/O Conn. 89Pos. Plug Housing Assembly Reverse (Female Connector)
1827021	Sealed 0.64/2.3 II I/O Conn. 112Pos. Plug Housing Assembly (Female Connector)
1827022	Sealed 0.64/2.3 II I/O Conn. 112Pos. Plug Housing Assembly Reverse (Female Connector)
1827014	Sealed 0.64/2.3 II I/O Conn. 74Pos. Plug Housing Assembly (Female Connector)
1827015	Sealed 0.64/2.3 II I/O Conn. 74Pos. Plug Housing Assembly Reverse (Female Connector)
1612283	Sealed 0.64/2.3 II I/O Conn. 60Pos. Plug Housing Assembly (Female Connector)
1747140	Sealed 0.64/2.3 II I/O Conn. 60Pos. Plug Housing Assembly Reverse (Female Connector)
1612281	Sealed 0.64/2.3 II I/O Conn. 126Pos. Lever
1612288	Sealed 0.64/2.3 II I/O Conn. 60Pos. Lever
1747139	Sealed 0.64/2.3 II I/O Conn. 126Pos. Lever Reverse
1747142	Sealed 0.64/2.3 II I/O Conn. 60Pos. Lever Reverse
1746941	Sealed 0.64/2.3 II I/O Conn. 126Pos. Wire Cover Type I (Right and Left Lock)
1746816	Sealed 0.64/2.3 II I/O Conn. 126Pos. Wire Cover Type II (One Side Lock)
1871551	Sealed 0.64/2.3 II I/O Conn. 126Pos. Wire Cover Type III (Right and Left Lock)
1903751	Sealed 0.64/2.3 II I/O Conn. 89Pos. Wire Cover Type V (Right and Left Lock)
1981831	Sealed 0.64/2.3 II I/O Conn. 126Pos. Wire Cover Type VI (One Side Lock)
1981984	Sealed 0.64/2.3 II I/O Conn. 126Pos. Wire Cover Type VII (Right and Left Lock)
2069839	Sealed 0.64/2.3 II I/O Conn. 112Pos. Wire Cover Type I (Right and Left Lock)
1871550	Sealed 0.64/2.3 II I/O Conn. 74Pos. Wire Cover Type I (Right and Left Lock)
2040169	Sealed 0.64/2.3 II I/O Conn. 74Pos. Wire Cover Type II (One Side Lock)
1746817	Sealed 0.64/2.3 II I/O Conn. 60Pos. Wire Cover Type I (One Side Lock)
1827114	Sealed 0.64/2.3 II I/O Conn. 60Pos. Wire Cover Type II (Right and Left Lock)
1939393	Sealed 0.64/2.3 II I/O Conn. 89/126Pos. Clip

Appendix 1 (To be continued)

★¹: Part number is consisted from listed base number and 1 digit numeric prefix and Suffix with dash. Refer to catalog or customer drawing for specific part numbers for each base number. When prefix is zero, zero and dash are omitted.

Part Number★ ¹	Description
1612290	Sealed 0.64 Receptacle (Sn)
	Sealed 0.64 Receptacle (Au)
2040168	Sealed 0.64 Receptacle L-size (Sn)
	Sealed 0.64 Receptacle L-size (Au)
	Sealed 2.3 II Receptacle (S size)★ ²
	Sealed 2.3 II Receptacle (M size)★ ²
	Sealed 2.3 II Receptacle (L size)★ ²

Appendix 1 (End)

★¹: Part number is consisted from listed base number and 1 digit numeric prefix and Suffix with dash. Refer to catalog or customer drawing for specific part numbers for each base number. When prefix is zero, zero and dash are omitted.

★²: See Manual of each maker about part number of 2.3 II receptacle contact.