

THIS DRAWING IS UNPUBLISHED.

RELEASED FOR PUBLICATION

ALL RIGHTS RESERVED.

© COPYRIGHT - By -

LOC	DIST	REVISIONS					
GP	00	P	LTR	DESCRIPTION	DATE	DWN	APVD
		G1		REVISED PER ECO-11-005033	22MAR11	RK	HMR

NOTES:

- ⚠ PITCH TOLERANCE TO BE $\pm .18[.007]$ FOR 1.27[.050] PITCH JUMPERS & $\pm .25[.010]$ FOR ALL REMAINING PITCHES. TOLERANCE TO BE NON CUMULATIVE OVER GAUGE LENGTH.
- ⚠ 11.92-152.40[.500-6.000] ARE STANDARD LENGTHS. JUMPERS ARE AVAILABLE IN INCREMENTS OF 2.50[.10] PLUS 6.35[.25] AND 19.05[.75].
- ⚠ DELETED
- ⚠ FOR CONDUCTOR PITCH 7 (2mm), ON PAGE 2 & 3, DIMENSION "B" IS 2.00[.079]
- ⚠ SPECIAL PIN LENGTHS ARE AVAILABLE FOR JUMPERS WITH A PIN CONFIGURATION OF "A" OR "B" ON LENGTHS OF UP TO 609.6[24.0] IN 2.54[.100] & 5.08[.200] PITCH VARIANTS ONLY BY ADDING THE FOLLOWING SUFFIXES:

SUFFIX	PEN LENGTH	TOLERANCE
V1	2.85 (.112)	$\pm .305$ [$\pm .012$]
V2	3.40 (.134)	
V3	4.10 (.161)	
V4	6.50 (.256)	
V5	3.10 (.122)	
V6	2.81 (.150)	
V7	4.50 (.177)	
V8	2.00 (.079)	
V9	TBD	
V10	.76 (.030)	
V11	2.41 (.095)	

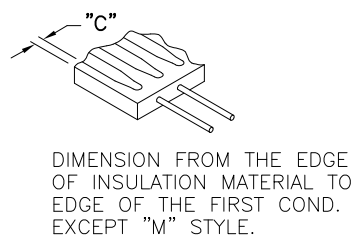

6. RECOMMENDED PCB HOLE DRILLING DETAILS ARE AS FOLLOWS:-

PITCH A	ϕG
1.27 (.050)	.70 (.028)
1.90 (.075)	.80 (.031)
2.54 (.100)	.95 (.037)
3.18 (.125)	.95 (.037)
3.81 (.150)	.95 (.037)
5.08 (.200)	.95 (.037)



JUMPER LENGTH	PITCH (NOMINAL)	TRANSITION MAX	MAX/MIN MARGIN	PIN DIAMETER	WIRE GAUGE (AWG)	MIN/MAX No OF CONDUCTORS	MAXIMUM ADHESIVE FLOW	MIN GAP BETWEEN CONDUCTORS	CONDUCTOR WIDTH	MAXIMUM INSULATION MISMATCH	MAX THICKNESS
R Δ_2	A Δ_1	T	C	E	-	-	V	X	Y	Z	D
11.93 (.50) TO 863.6 (30.00) IN STEPS OF 2.50 (.10) PLUS 6.35 (.25) AND 19.05 (.75)	1.00 (0.039)	4.32 [.170]	0.35 (0.014) 0.17 (0.007)	0.330 (.0130) 0.317 (.0125)	28	2-70	0.38 (0.015)	0.13 (0.009)	0.76 (.030) 0.56 (.022)	.76 (.030)	.64
	1.25 (0.049)	4.32 [.170]	0.50 (0.020) 0.17 (0.007)	0.330 (.0130) 0.317 (.0125)	28	2-70	0.38 (0.015)	0.25 (0.010)	0.89 (.035) 0.64 (.025)	.76 (.030)	.64
	1.27 (0.050)	4.32 [.170]	0.50 (0.020) 0.17 (0.007)	0.330 (.0130) 0.317 (.0125)	28	2-70	0.38 (0.015)	0.25 (0.010)	0.89 (.035) 0.64 (.025)	.76 (.030)	.64
	2.00 (0.079)	5.08 [.200]	0.70 (0.028) 0.25 (0.010)	0.416 (.0164) 0.400 (.0157)	26	2-50	0.38 (0.015)	0.38 (0.015)	1.14 (.045) 0.89 (.035)	.76 (.030)	.84
	1.90 (0.075)	5.08 [.200]	0.70 (0.028) 0.25 (0.010)	0.416 (.0164) 0.400 (.0157)	26	2-50	0.38 (0.015)	0.38 (0.015)	1.14 (.045) 0.89 (.035)	.76 (.030)	.84
	2.54 (0.100)	6.35 [.250]	0.80 (0.031) 0.25 (0.010)	0.526 (.0207) 0.505 (.0199)	24	2-50	0.51 (0.020)	0.51 (0.020)	1.52 (.060) 1.27 (.050)	.76 (.030)	.84
	3.18 (0.125)	6.35 [.250]	1.00 (0.039) 0.25 (0.010)	0.526 (.0207) 0.505 (.0199)	24	2-25	0.51 (0.020)	0.51 (0.020)	1.52 (.060) 1.27 (.050)	.76 (.030)	.84
	3.81 (0.150)	6.35 [.250]	1.00 (0.039) 0.25 (0.010)	0.526 (.0207) 0.505 (.0199)	24	2-20	0.51 (0.020)	0.51 (0.020)	1.52 (.060) 1.27 (.050)	.76 (.030)	.84
	5.08 (0.200)	6.35 [.250]	1.00 (0.039) 0.25 (0.010)	0.526 (.0207) 0.505 (.0199)	24	2-15	0.51 (0.020)	0.51 (0.020)	1.52 (.060) 1.27 (.050)	.76 (.030)	.84

- ⚠ BEND RADIUS TO APPLY ONLY IN THE FLAT SECTION OF JUMPER BETWEEN THE CONDUCTOR TRANSITION AREAS.
- ⚠ PER 108-2135.
- 9. TOOL MARKS PERMISSIBLE ON BENDS. NO EXPOSED COPPER.
- ⚠ PIN DIAMETER SPECIFIED NOT APPLICABLE IN BENDING AREA OF PIN, DUE TO NORMAL DEFORMATION OF BENDING PROCESS.
- ⚠ REFER TO RELEVANT MATERIAL SPECIFICATIONS.

F - MID POINT THICKNESS BETWEEN PT 1 & PT 2	MINIMUM	MAXIMUM
	NOMEX	.152 [.006]
POLYESTER	.152 [.006]	.305 [.012]
KAPTON	.102 [.004]	.254 [.010]
TEFLON	.305 [.012]	.533 [.021]

12. PRODUCT AND PROCESSING MUST MEET REQUIREMENTS OF TE CONNECTIVITY STANDARD 230-702.

THIS DRAWING IS A CONTROLLED DOCUMENT.

DWN J. SCHWARTZ 28FEB01
CHK E. FOX 28FEB01
APVD E. FOX 28FEB01

NAME: FLEXSTRIP PIN CONFIGURATIONS, GENERIC

SIZE: A3 CAGE CODE: 00779 DRAWING NO: C-1474339 RESTRICTED TO: -

MATERIAL: - FINISH: - WEIGHT: -

CUSTOMER DRAWING SCALE: N.T.S. SHEET: 1 OF 4 REV: G1

THIS DRAWING IS UNPUBLISHED. RELEASED FOR PUBLICATION - - -

© COPYRIGHT - By - ALL RIGHTS RESERVED.

LOC GP DIST 00

P		LTR	DESCRIPTION	DATE	DWN	APVD
		-	SEE SHEET 1	-	-	-

A - STRAIGHT PINS

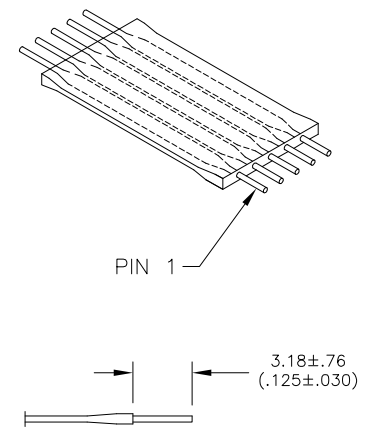

B - RIGHT ANGLE PINS (BENT DOWN)

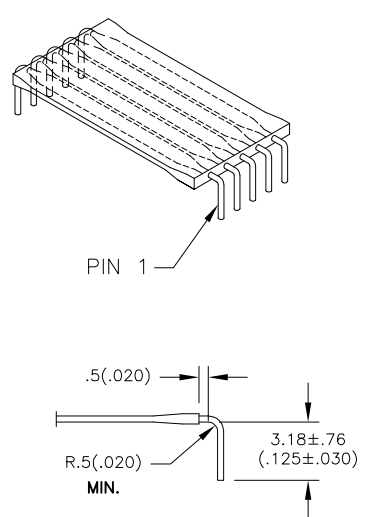

C - RIGHT ANGLE STAGGERED PINS (PIN 1 SHORT, BENT DOWN)

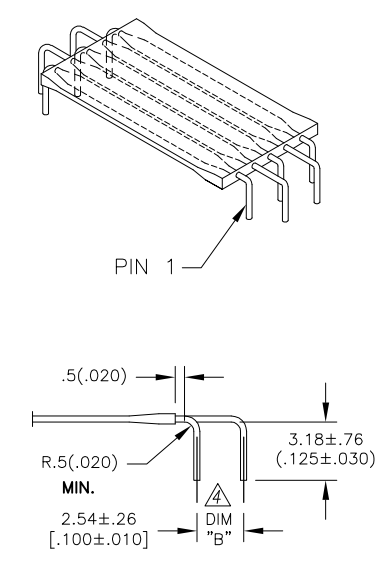

D - STRAIGHT ANGLE STAGGERED PINS (PIN 1 STRAIGHT)

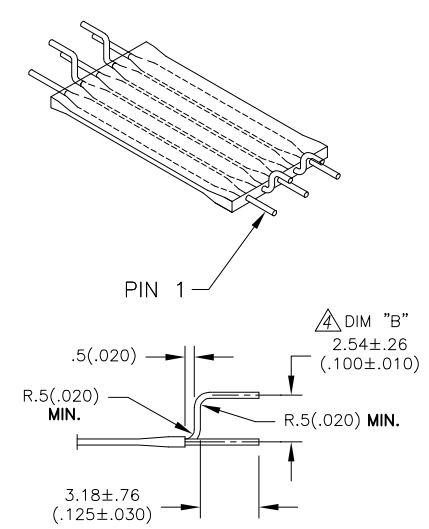

STANDARD JUMPERS ORDERING CODE/CATALOGUE NUMBER

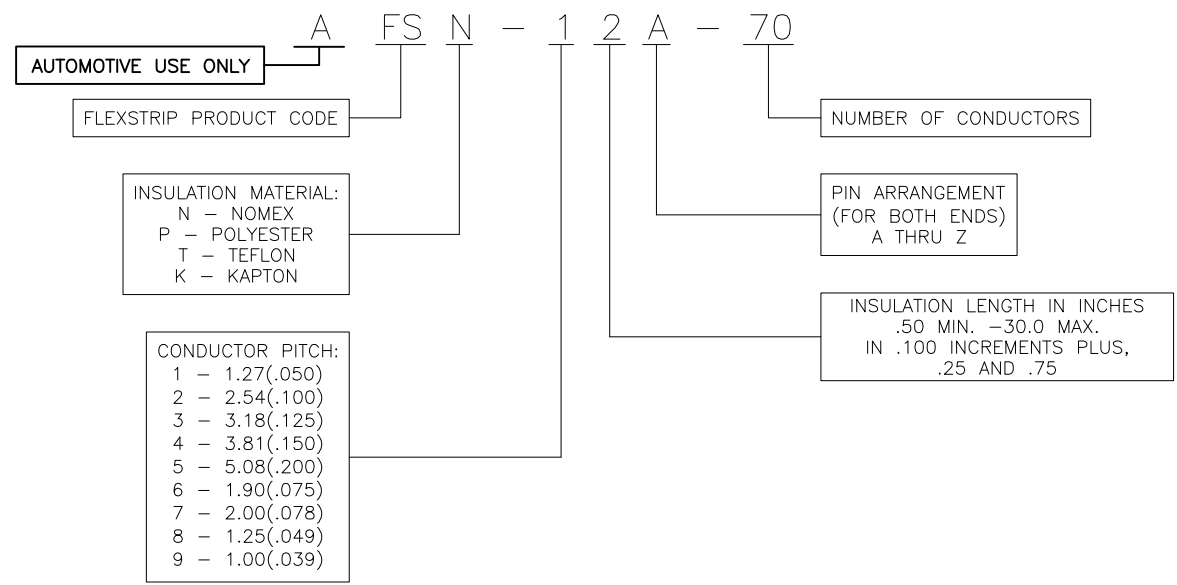

MANUFACTURING NOTE: MINIMUM GAP BETWEEN STRIPS

SK/A/Z	.75 INCH
LP	1.1 INCH

MINIMUM CONDUCTOR COUNT PER STRIP FOR LINE JOBS

PITCH	CONDUCTOR
1 1.27 (.050)	60
2 2.54 (.100)	60
3 3.18 (.125)	60
4 3.81 (.150)	50
5 5.08 (.200)	40
6 1.91 (.075)	60
7 2.0 (.078)	60
8 1.24 (.049)	60
9 1.0 (.039)	80

STANDARD LINE JOBS

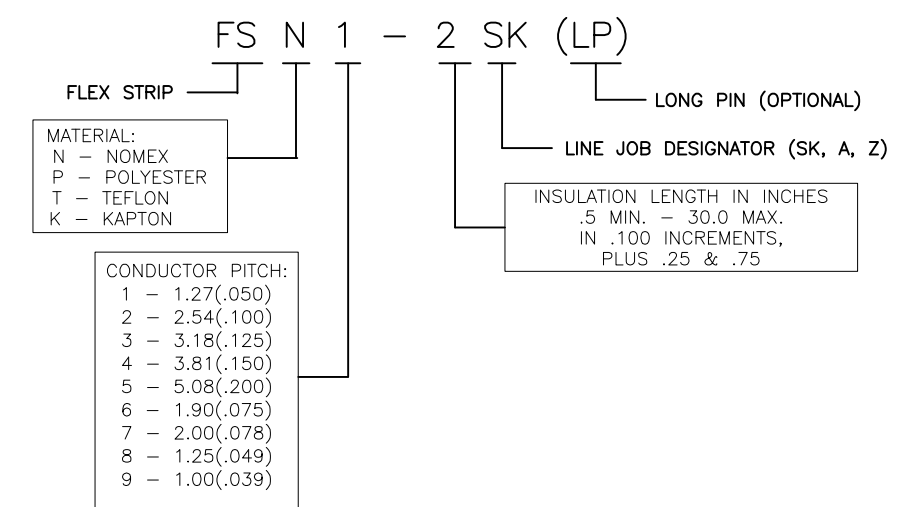

THE FOLLOWING ORDERING CODE IS A SPECIAL FOR TE CONNECTIVITY GERMANY DESCRIBING A STRIP OF ANY INSULATION MATERIAL, ANY PITCH AND ANY INSULATION LENGTH WITH A 11.00[.433] MIN PIN LENGTH UNLESS OTHERWISE SPECIFIED:-

FS X-X X J-A A W

THIS DRAWING IS A CONTROLLED DOCUMENT.

DIMENSIONS: MM [INCHES]	TOLERANCES UNLESS OTHERWISE SPECIFIED:
	0 PLC ± -
	1 PLC ± -
	2 PLC ± -
	3 PLC ± -
	4 PLC ± -
	ANGLES ± 1/2°
MATERIAL	FINISH
-	-

DWN	J. SCHWARTZ	28FEB01
CHK	E. FOX	28FEB01
APVD	E. FOX	28FEB01
PRODUCT SPEC	-	-
APPLICATION SPEC	-	-
WEIGHT	-	-

		TE Connectivity	
		NAME FLEXSTRIP PIN CONFIGURATIONS, GENERIC	
SIZE	CAGE CODE	DRAWING NO	RESTRICTED TO
A3	00779	C-1474339	-
CUSTOMER DRAWING		SCALE N.T.S.	SHEET 2 OF 4 REV G1

THIS DRAWING IS UNPUBLISHED.

RELEASED FOR PUBLICATION

ALL RIGHTS RESERVED.

© COPYRIGHT - By -

LOC GP DIST 00

REVISIONS

P	LTR	DESCRIPTION	DATE	DWN	APVD
-	-	SEE SHEET 1	-	-	-

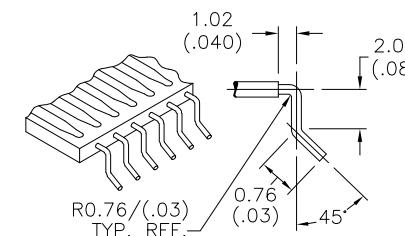
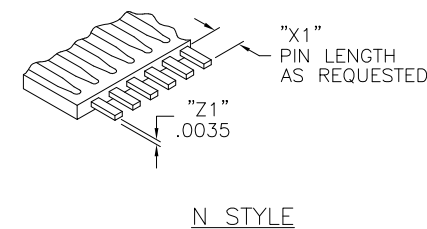
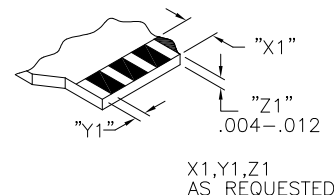
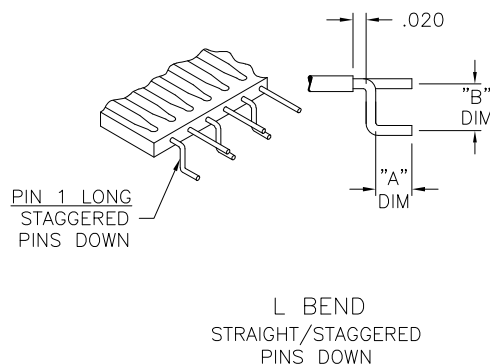
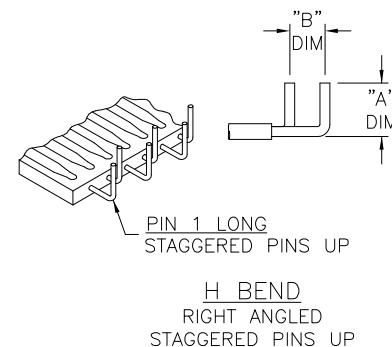
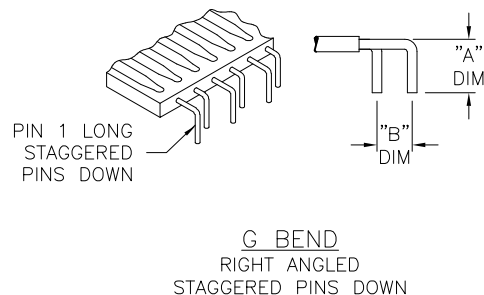
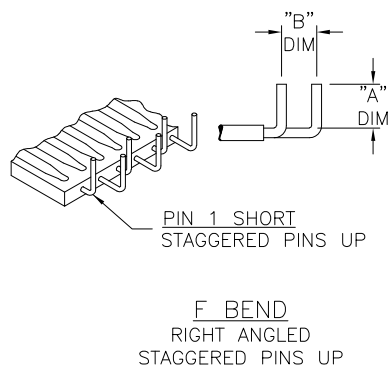

SPECIAL JUMPERS
ORDERING CODE/CATALOGUE NUMBER

FS N - 1 3.25 A G - 20 V1 (SEE NOTE 5)

FLEXSTRIP PRODUCT CODE

INSULATION MATERIAL:
N - NOMEX
P - POLYESTER
T - TEFLON
K - KAPTON

CONDUCTOR PITCH:
1 - 1.27(.050)
2 - 2.54(.100)
3 - 3.18(.125)
4 - 3.81(.150)
5 - 5.08(.200)
6 - 1.90(.075)
7 - 2.00(.078)
8 - 1.25(.049)
9 - 1.00(.039)

INSULATION LENGTH: (in inches)
.50 MIN. - 30.0 MAX.
IN .10 INCREMENTS PLUS .25 AND .50

SPECIAL PIN LENGTH
V1 - 2.84(.112)
V2 - 3.40(.134)
V3 - 4.09(.161)
V4 - 6.50(.256)
V5 - 3.01(.122)
V6 - 3.81(.150)
V7 - 4.50(.177)
V8 - 2.01(.079)
V9 - TBD
V10 - .76 (.030)
V11 - 2.41(.095)

NUMBER OF CONDUCTORS (SEE MAX./MIN. PAGE 1)

PIN ARRANGEMENT (RIGHT)

PIN ARRANGEMENT (LEFT)

CONDUCTOR PITCH	BENDS AVAILABLE
1 - 1.27/(.050)	E,F,G,H,J,K,L,M
2 - 2.54/(.100)	E,F,G,H,J,K,L,R,M
3 - 3.18/(.125)	E
4 - 3.81/(.150)	E
5 - 5.08/(.200)	E
6 - 1.91/(.075)	E,F,G,H,J,K,L
7 - 2.00/(.0787)	E,F,G,H,J,K,L
8 - 1.25/(.049)	E
9 - 1.00/(.039)	E, M

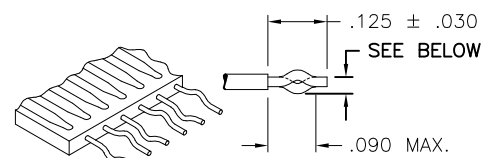

SPECIAL FLEXSTRIP BENDS
SPECIAL FLEXSTRIP BENDS
E THRU R, AND Z MAY APPLY TO EITHER
LEFT OF RIGHT SIDE

E THRU L BEND
"A" DIM
3.18±0.76/(.125±.030)
"B" DIM
2.54±0.25/(.100±.010)

THIS DRAWING IS A CONTROLLED DOCUMENT.

DIMENSIONS: MM [INCHES]	TOLERANCES UNLESS OTHERWISE SPECIFIED:
	0 PLC ± -
	1 PLC ± -
	2 PLC ± -
	3 PLC ± -
	4 PLC ± -
	ANGLES ± 1/2°
MATERIAL	FINISH

DWN	J. SCHWARTZ	28FEB01
CHK	E. FOX	28FEB01
APVD	E. FOX	28FEB01
PRODUCT SPEC	-	-
APPLICATION SPEC	-	-
WEIGHT	-	-
CUSTOMER DRAWING		

TE Connectivity		NAME	
		FLEXSTRIP PIN CONFIGURATIONS, GENERIC	
SIZE	CAGE CODE	DRAWING NO	RESTRICTED TO
A3	00779	C-1474339	-
SCALE		SHEET	REV
N.T.S.		3 OF 4	G1

THIS DRAWING IS UNPUBLISHED. RELEASED FOR PUBLICATION
 © COPYRIGHT - By - ALL RIGHTS RESERVED.

LOC GP	DIST 00	REVISIONS			
P	LTR	DESCRIPTION	DATE	DWN	APVD
	-	SEE SHEET 1	-	-	-

NORMAL CONDUCTOR PITCH		1.00 (.039)	1.25 (.049)	1.27 (.050)	1.90 (.075)	2.00 (.078)	2.54 (.100)	3.18 (.125)	3.81 (.150)	5.08 (.200)	7.62 (.300)
WIRE GAUGE		AWG 28	AWG 28	AWG 28	AWG 26	AWG 26	AWG 24	AWG 24	AWG 24	AWG 24	AWG 24
NOMINAL WIRE DIAMETER		.32(.0126)	.32(.0126)	.32(.0126)	.40(.0159)	.40(.0159)	.51(.0201)	.51(.0201)	.51(.0201)	.51(.0201)	.51(.0201)
CURRENT RATING		1.0A	1.6A	1.6A	2.0A	2.0A	3.0A	3.5A	3.5A	4.0A	4.0A
VOLTAGE RATING		200VAC	200VAC	200VAC	200VAC	200VAC	300VAC	300VAC	300VAC	300VAC	300VAC
MAX NUMBER OF CONDUCTORS PER JUMPER		70	70	70	50	50	48	30	25	20	13
MIN BREAKDOWN VOLTAGE @ 1 MIN		1025VAC	1050VAC	1050VAC	1250VAC	1250VAC	1500VAC	1500VAC	1500VAC	1500VAC	1500VAC
INSULATION RESISTANCE (GND. SIG. GND) 305 (12") SAMPLE @ 500VDC	P N T K	△ ₈	△ ₈	△ ₈	△ ₈	△ ₈	△ ₈	△ ₈	△ ₈	△ ₈	△ ₈
CAPACITANCE (pf / 50.8 (12") LENGTH) (GND, SIG, GND) (AVERAGE)	P N T K	△ ₈	△ ₈	△ ₈	△ ₈	△ ₈	△ ₈	△ ₈	△ ₈	△ ₈	△ ₈
CHARACTERISTIC IMPEDANCE (GND. SIG. GND) (AVERAGE)	P N T K	△ ₈	△ ₈	△ ₈	△ ₈	△ ₈	△ ₈	△ ₈	△ ₈	△ ₈	△ ₈
APPLICATION TEMP RANGE (C°) (FOR SOLDERING)	P N T K	200 / 4 sec 200 / 4 sec 240 / 4 sec 240 / 4 sec	200 / 4 sec 200 / 4 sec 240 / 4 sec 240 / 4 sec	200 / 4 sec 200 / 4 sec 240 / 4 sec 240 / 4 sec	200 / 4 sec 200 / 4 sec 240 / 4 sec 240 / 4 sec	200 / 4 sec 200 / 4 sec 240 / 4 sec 240 / 4 sec	250 / 4 sec 250 / 4 sec 260 / 5 sec 260 / 5 sec	250 / 4 sec 250 / 4 sec 260 / 5 sec 260 / 5 sec	250 / 4 sec 250 / 4 sec 260 / 5 sec 260 / 5 sec	250 / 4 sec 250 / 4 sec 260 / 5 sec 260 / 5 sec	250 / 4 sec 250 / 4 sec 260 / 5 sec 260 / 5 sec
OPERATING TEMPERATURE (C°)	P N T K	-40 to 105 (For all Conductor Pitches) -40 to 125 (For all Conductor Pitches) -40 to 150 (For all Conductor Pitches) -40 to 150 (For all Conductor Pitches)									
MINIMUM BEND RADIUS	P N T K	3.18mm (For all Conductor Pitches) 3.18mm (For all Conductor Pitches) 3.18mm (For all Conductor Pitches) 3.18mm (For all Conductor Pitches)									
UL STYLE NUMBER	P N T K	2639 (For all Conductor Pitches .100 and above) 5188 (For all Conductor Pitches .100 and above) 2928 (For all Conductor Pitches .100 and above) 2927 (For all Conductor Pitches .100 and above)									

ABR.	MATERIAL	SPECIFICATION
	COPPER WIRE	100-1577
P	POLYESTER	100-1575
N	NOMEX	100-1758
T	TEFLON	100-1574
K	KAPTON	100-1576

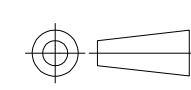
THIS DRAWING IS A CONTROLLED DOCUMENT.		DWN J. SCHWARTZ 28FEB01	 TE Connectivity			
DIMENSIONS: MM [INCHES]		CHK E. FOX 28FEB01				
TOLERANCES UNLESS OTHERWISE SPECIFIED:		APVD E. FOX 28FEB01	NAME FLEXSTRIP PIN CONFIGURATIONS, GENERIC			
 0 PLC ± - 1 PLC ± - 2 PLC ± - 3 PLC ± - 4 PLC ± - ANGLES ± 1/2°		PRODUCT SPEC -	RESTRICTED TO -			
MATERIAL -		FINISH -	APPLICATION SPEC -	SIZE A3	CAGE CODE 00779	DRAWING NO C-1474339
CUSTOMER DRAWING			SCALE N.T.S.	SHEET 4 OF 4	REV G1	