



PRODUCT SPECIFICATION

Attn: _____

SPEC. No: _____

DATE: July.05.2012

CUSTOMER PRODUCT NAME:
TDK PRODUCT NAME: WT-525225-20K2-A1-G
THIS SPECIFICATION IS:

TDK-EPC Corporation

Head Office Address:

1-13-1, Nihonbashi, Chuo-ku, Tokyo
103-0027, Japan

SALES

MANAGER	SALES

ENGINEERING

APPROVED	CHECKED	ISSUED

Sales Office _____

Sales Tel. _____

PRODUCT CLASSIFICATION CODE	
-----------------------------	--

REVISED HISTORY

CUSTOMER PRODUCT NAME: _____

TDK PRODUCT NAME: WT-525225-20K2-A1-G

NO.	REV.	REVISED CONTENT	REVISED REASON	DATE
1	0	To establish specification		2012.07.05

PRODUCT SPECIFICATION

TDK PRODUCT NAME: WT-525225-20K2-A1-G	SPEC. NO.	CUSTOMER PRODUCT NAME:
---	-----------	------------------------

(1) Apperance & Dimensions (Unit: mm)

Weight: 46.7g (Typ.)

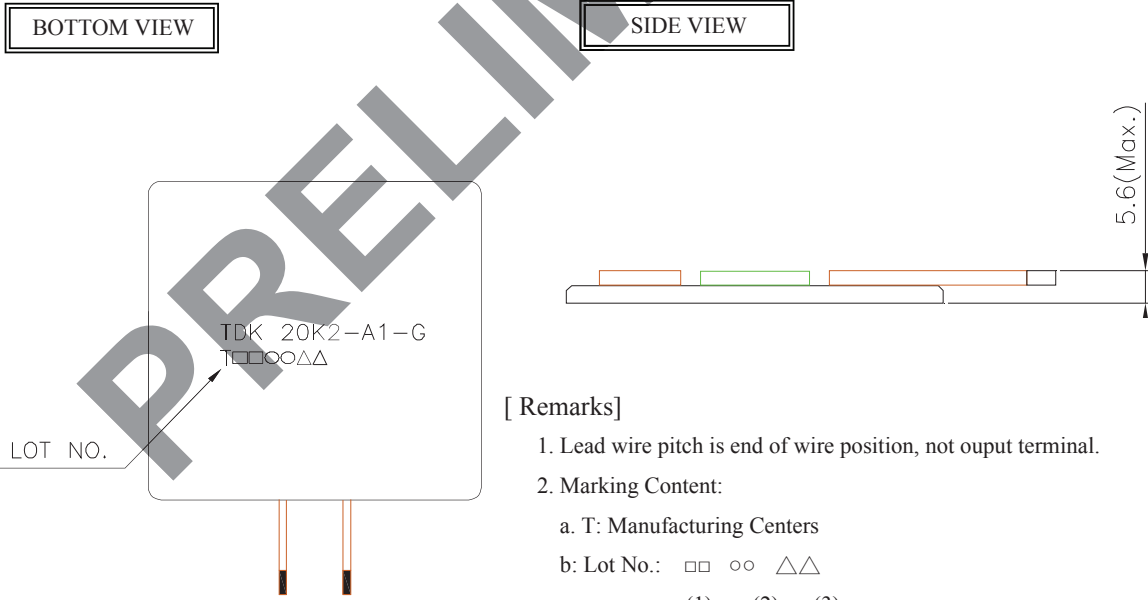
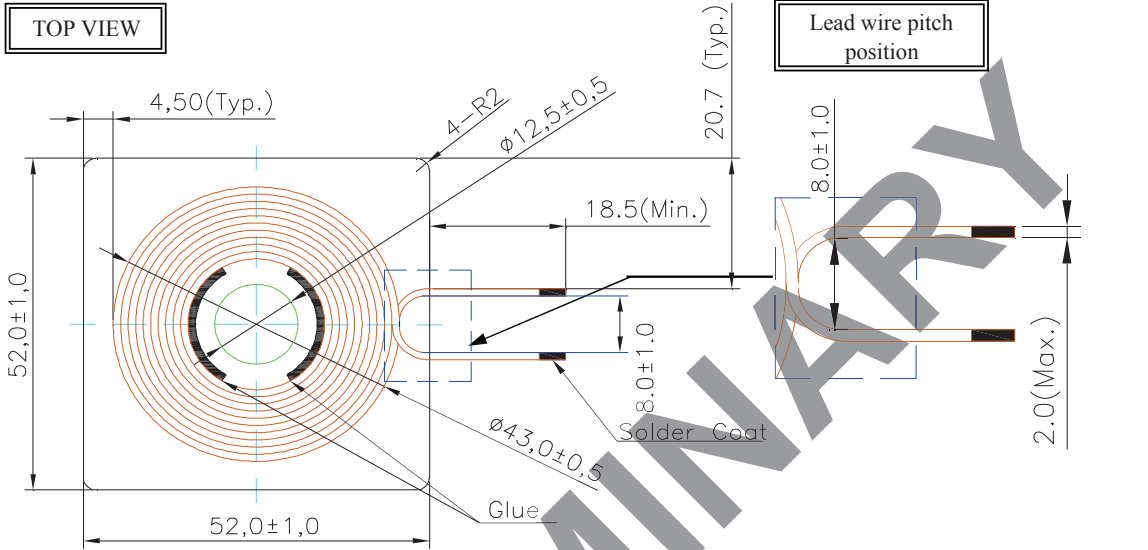

[Remarks]

1. Lead wire pitch is end of wire position, not ouput terminal.
2. Marking Content:
 - a. T: Manufacturing Centers
 - b: Lot No.: □ □ ○ ○ △ △
 - (1) (2) (3)
 - (1) Year: A.D. end number in double
 - (2) Month: Jan.(1), Feb.(02)...Dec.(12)
 - (3) Day: 01,02,03,...31.

PRODUCT SPECIFICATION

TDK PRODUCT NAME:

WT-525225-20K2-A1-G

SPEC. NO.

CUSTOMER PRODUCT NAME:

(2) Air coil specification

Wire Diameter: $\phi 0.08\text{mm} \times 105$ (Type2 Wire)

Coil Turns: 20TS (10Ts / 1 layer, Total 2 layers)

(3) Electrical Characteristics

No.	Parameter	Specification	Test Instrument
1	Inductance	24.0 $\mu\text{H} \pm 10\%$	HP 4284A DIGITAL LCR METER or EQUIVALENT (@100kHz 1.0 Vrms)
2	Q Value	80 (Min.)	HP 4284A DIGITAL LCR METER or EQUIVALENT (@100kHz 1.0 Vrms)
3	DC Resistance	0.10 Ω (Max.) (At 25°C)	CHEN HWA 502A OHM METER or EQUIVALENT

(4) Temperature Characteristics

No.	Parameter	Specification
1	Operating Temperature	-30~70°C
2	Storage Temperature	-40~85°C

(5) Application

1. The product fit in with RoHS rule.
2. The product fit in with Halogen-Free.
3. Reflow and dip-flow soldering can not used for this product.

PRODUCT SPECIFICATION

TDK PRODUCT NAME:

WT-525225-20K2-A1-G

SPEC. NO.

CUSTOMER PRODUCT NAME:

(6) Reliability Conditions

No.	Parameter	Conditions
1	Low Temperature (Storage)	(1) Temperature : $-40\pm 2^{\circ}\text{C}$ (2) Time : 240Hrs
2	High Temperature (Storage)	(1) Temperature : $+85\pm 2^{\circ}\text{C}$ (2) Time : 240Hrs
3	Thermal Shock	(1) Temperature : $-40\pm 5^{\circ}\text{C}$ / 30min ~ $+85\pm 5^{\circ}\text{C}$ / 30min (2) Ambient Time : 5min (3) Times : 100cycles
4	Vibration	Unpacked: (1) frequency: 10~500Hz sweep 1 octave wave / 1 min (2) Amplitude: 1.5mm (p-p) or 10G (3) Direction: X.Y.Z. direction (4) Time: X.Y.Z for 2 hours each.
5	Temperature / Humidity (Storage)	(1) Temperature : $+60\pm 2^{\circ}\text{C}$ (2) Humidity: 90% RH. (3) Time: 240Hrs
6	Temperature / Humidity (OP)	(1) Temperature : $+60\pm 2^{\circ}\text{C}$ (2) Humidity: 90% RH. (3) Time: 240Hrs (4) Current: DC 1.0A (5) Frequency: 100kHz
7	Package Drop	(1) Drop the sample package in a carton box. (2) Height : 100 cm (3) Direction : 1corner, 3 edges, 6 faces (4) Drop time : 16 times
8	ESD(HBM)	(1) Test Voltage: 1000V (2) Ambient: $25\pm 5^{\circ}\text{C}$ (3) Time: Negative / Positive each 1 time (4) Resistance: 1500Ω (5) Capacitance: 100pF
9	ESD(MM)	(1) Test Voltage: 100V (2) Ambient: $25\pm 5^{\circ}\text{C}$ (3) Time: Negative / Positive each 1 time (4) Capacitance: 200pF

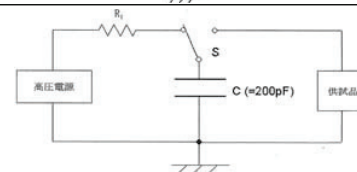
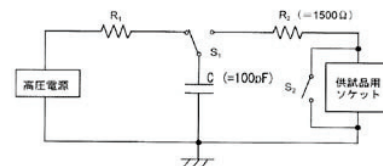

PRODUCT SPECIFICATION

TDK PRODUCT NAME:

WT-525225-20K2-A1-G

SPEC. NO.

CUSTOMER PRODUCT NAME:

(7) Construction

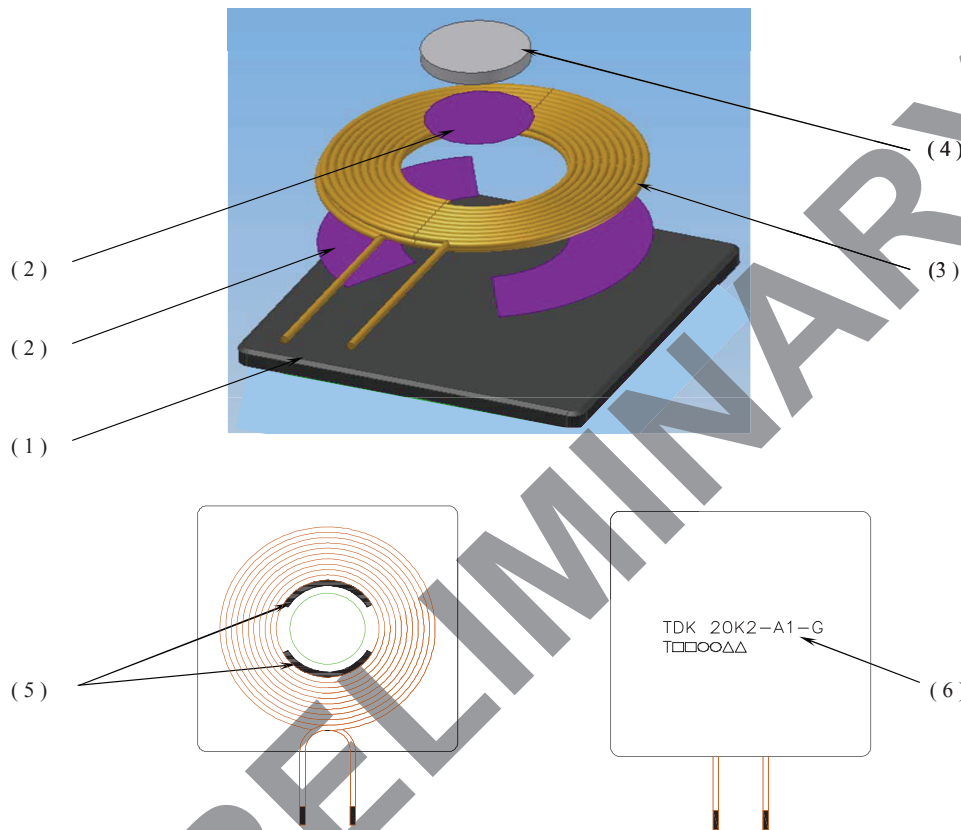

(8) Material List

No.	Material Name
1	Ferrite Sheet
2	Adhesive Tape
3	Air Coil
4	Bonded Magnet
5	Glue
6	Ink

PRODUCT SPECIFICATION

TDK PRODUCT NAME: WT-525225-20K2-A1-G	SPEC. NO.	CUSTOMER PRODUCT NAME:
---	-----------	------------------------

(9) Packing

1. To stack the the Trays onto 2 Layers and insert the cardboard between tray:

- PET tray dimension: 326*329*11.5mm (REF.)
- Cardboard dimension: 320*320*3 mm (REF.)
- 12 Pcs / per PET tray

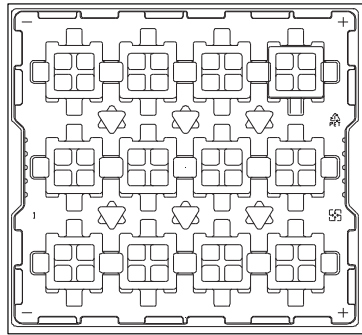

Total : 4x3=12pcs

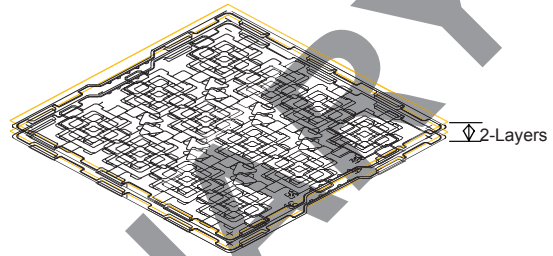

Total : 12x2=24pcs

2. To put 2 Trays of products into the small Carton and affixing the out-going label on the outside .

- Small carton dimension: 331*337*33mm (REF.)
- 2 PET Trays / per small carton

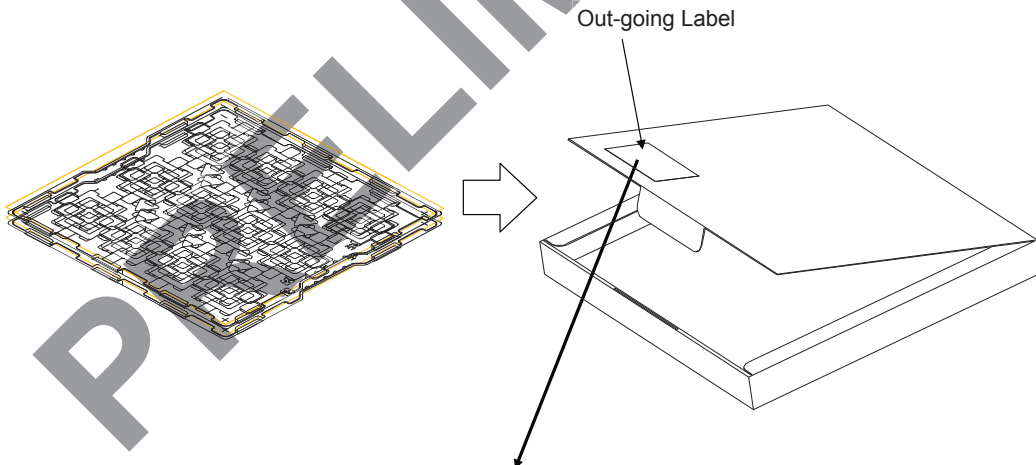

Out-going Label

PRODUCT SPECIFICATION

TDK PRODUCT NAME: WT-525225-20K2-A1-G	SPEC. NO.	CUSTOMER PRODUCT NAME:
---	-----------	------------------------

- To put 3 small carton into the Carton .
 - Outer carton dimension: 347*340*124mm (REF.)
 - 3 small cartons / per outer carton
 - Total quantity : 72 Pcs

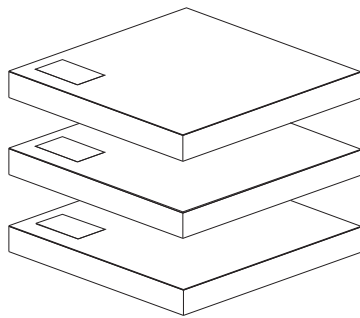

3 small cartons

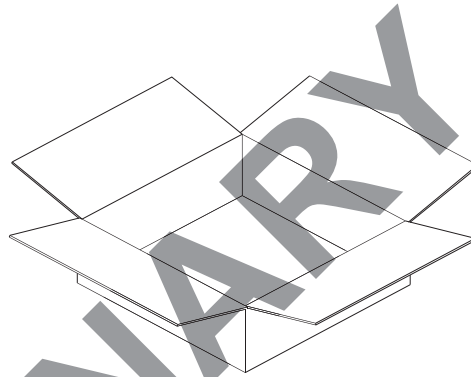

Outer carton

4. Packing.

- To pack the carton by scotch tape and affix out-going label (outside) on it outside.
- The Inspection data in the box , there would be a signet mark on it outside.

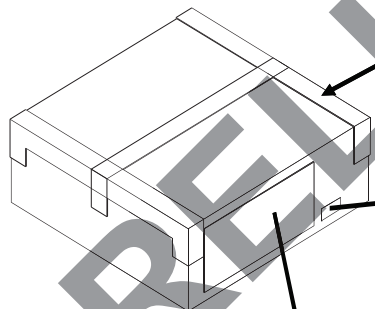

scotch tape



signet mark of Inspection data

(3S) TITW=WL12K0600200101400000360		CUSTOMER: Customer	
		CUST. PART NO(P): 12A34567-89A	
(6S) C/NO:1	BOX COUNT		
	001/009	TDK ITEM CODE(GP): TTXDF12345TWN	
SHIPPING MARK	ROHS		
<p>SAMPLE</p> <p>Foxconn</p> <p>Location</p> <p>MADE IN TAIWAN</p> <p>WL12K34567</p> <p>12345A6789</p>	P/O NO.(K): TTTT-S123456789		
	LOT NO.(IT): WL12345678		DATE: Nov.22.2011
	QTY(Q): 288		
		TDK ITEM (IP): WT-525225-20K2-A1-G	
		(WT-525225-20K2-A1-G)	
		SUB P/O NO.(GK): 4500059424	
		TDK SPEC.	
C/NO : 1	WAREHOUSE	(CT)	
	NW 3.6 GW 4.0		TDK TAIWAN CORPORATION YANGMEI, TAIWAN 9 TTXDF10105

out-going label