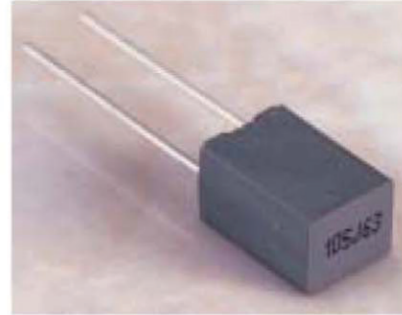
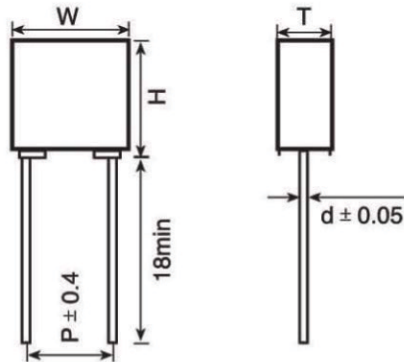

Outline Drawing

Features

- High dv/dt ability and small size due to stacked construction
- All parts RoHS compliant

Specifications

Reference Standard	GB7332 (IEC 60384-2)		
Climatic Category	55/100/56		
Rated Temperature	85°C		
Operating Temperature Range	-55°C~105°C (+85°C to +105°C: decreasing factor 1.25% per °C for $V_R(\text{DC})$)		
Rated Voltage	50/63V、100V、250V、400V、500V、630V		
Capacitance Range	0.0010 μF ~1.5 μF		
Capacitance Tolerance	$\pm 5\%$ (J), $\pm 10\%$ (K), $\pm 20\%$ (M)		
Voltage Proof	I: $1.6U_R$ (5s) 、 II: $1.4U_R$ (5s)		
Dissipation Factor	Frequency	$C_R < 0.1 \mu\text{F}$	$C_R > 0.1 \mu\text{F}$
	1kHz	$< 1.0\%$	$< 1.0\%$
	10kHz	$< 1.5\%$	$< 1.5\%$
	100kHz	$< 3.0\%$	—
Insulation Resistance	$U_R > 100\text{V}$	$> 30\,000\text{M}\Omega$, $C_R < 0.33\mu\text{F}$ (20°C, 100V, 1min)	
	$U_R < 100\text{V}$	$> 15\,000\text{M}\Omega$, $C_R < 0.33\mu\text{F}$ $> 5\,000\text{s}$, $C_R > 0.33\mu\text{F}$ (20°C, 10V, 1min)	
Maximum Pulse Rise Time (dv/dt): If the working voltage (U) is lower than the rated voltage (U_R),the capacitor can be worked at a higher dv/dt .In this case, the maximum allowed dv/dt is obtain by multiplying the right value with U_R/U .	$U_R(\text{V})$	$dv/dt(\text{V}/\mu\text{s})$	
	50/63	250	
	100	300	
	250	400	
	400	600	
	500	700	
	630	800	

■ Dimensions(mm)

Capacitor Thickness T	<3.5	>3.5
Lead Wire Dia. d ± 0.05	0.5	0.6
Dimension Tolerance: W,H,T	± 0.2	± 0.4

I Pattern I

(μF)	50/63VDC			100VDC			250VDC			400VDC			500VDC			630VDC		
	W	H	T	W	H	T	W	H	T	W	H	T	W	H	T	W	H	T
0.0010	7.2	6.5	2.5	7.2	6.5	2.5	7.2	6.5	2.5	7.2	6.5	2.5	7.2	6.5	2.5	7.2	6.5	2.5
0.0012	7.2	6.5	2.5	7.2	6.5	2.5	7.2	6.5	2.5	7.2	6.5	2.5	7.2	6.5	2.5	7.2	6.5	2.5
0.0015	7.2	6.5	2.5	7.2	6.5	2.5	7.2	6.5	2.5	7.2	6.5	2.5	7.2	6.5	2.5	7.2	6.5	2.5
0.0018	7.2	6.5	2.5	7.2	6.5	2.5	7.2	6.5	2.5	7.2	6.5	2.5	7.2	6.5	2.5	7.2	7.5	3.5
0.0022	7.2	6.5	2.5	7.2	6.5	2.5	7.2	6.5	2.5	7.2	6.5	2.5	7.2	6.5	2.5	7.2	7.5	3.5
0.0027	7.2	6.5	2.5	7.2	6.5	2.5	7.2	6.5	2.5	7.2	6.5	2.5	7.2	6.5	2.5	7.2	7.5	3.5
0.0033	7.2	6.5	2.5	7.2	6.5	2.5	7.2	6.5	2.5	7.2	6.5	2.5	7.2	7.5	3.5	7.2	7.5	3.5
0.0039	7.2	6.5	2.5	7.2	6.5	2.5	7.2	6.5	2.5	7.2	6.5	2.5	7.2	7.5	3.5	7.2	7.5	3.5
0.0047	7.2	6.5	2.5	7.2	6.5	2.5	7.2	6.5	2.5	7.2	6.5	2.5	7.2	7.5	3.5	7.2	9.5	4.5
0.0056	7.2	6.5	2.5	7.2	6.5	2.5	7.2	6.5	2.5	7.2	7.5	3.5	7.2	7.5	3.5	7.2	9.5	4.5
0.0068	7.2	6.5	2.5	7.2	6.5	2.5	7.2	6.5	2.5	7.2	7.5	3.5	7.2	9.5	4.5	7.2	9.5	4.5
0.0082	7.2	6.5	2.5	7.2	6.5	2.5	7.2	6.5	2.5	7.2	7.5	3.5	7.2	9.5	4.5	7.2	9.5	4.5
0.010	7.2	6.5	2.5	7.2	6.5	2.5	7.2	6.5	2.5	7.2	7.5	3.5	7.2	9.5	4.5	7.2	10.0	5.0
0.012	7.2	6.5	2.5	7.2	6.5	2.5	7.2	6.5	2.5	7.2	9.5	4.5	7.2	9.5	4.5	7.2	11.0	6.0
0.015	7.2	6.5	2.5	7.2	6.5	2.5	7.2	6.5	2.5	7.2	9.5	4.5	7.2	10.0	5.0	7.2	11.0	6.0
0.018	7.2	6.5	2.5	7.2	6.5	2.5	7.2	6.5	2.5	7.2	9.5	4.5	7.2	11.0	6.0			
0.022	7.2	6.5	2.5	7.2	6.5	2.5	7.2	7.5	3.5	7.2	10.0	5.0	7.2	11.0	6.0			
0.027	7.2	6.5	2.5	7.2	6.5	2.5	7.2	7.5	3.5	7.2	11.0	6.0	7.2	11.0	6.0			
0.033	7.2	6.5	2.5	7.2	6.5	2.5	7.2	7.5	3.5	7.2	11.0	6.0						
0.039	7.2	6.5	2.5	7.2	6.5	2.5	7.2	7.5	3.5	7.2	11.0	6.0						
0.047	7.2	6.5	2.5	7.2	6.5	2.5	7.2	9.5	4.5	7.2	11.0	6.0						
0.056	7.2	6.5	2.5	7.2	6.5	2.5	7.2	9.5	4.5									
0.068	7.2	6.5	2.5	7.2	6.5	2.5	7.2	9.5	4.5									
0.082	7.2	6.5	2.5	7.2	6.5	2.5	7.2	10.0	5.0									
0.10	7.2	6.5	2.5	7.2	7.5	3.5	7.2	10.0	5.0									
0.12	7.2	6.5	2.5	7.2	9.5	4.5	7.2	11.0	6.0									
0.15	7.2	7.5	3.5	7.2	9.5	4.5	7.2	11.0	6.0									
0.18	7.2	7.5	3.5	7.2	9.5	4.5												
0.22	7.2	7.5	3.5	7.2	10.0	5.0												
0.27	7.2	9.5	4.5	7.2	10.0	5.0												
0.33	7.2	9.5	4.5	7.2	11.0	6.0												
0.39	7.2	9.5	4.5	7.2	11.0	6.0												
0.47	7.2	10.0	5.0	7.2	11.0	6.0												
0.56	7.2	10.0	5.0	7.2	11.0	6.0												
0.68	7.2	11.0	6.0															
0.82	7.2	11.0	6.0															
1.0	7.2	11.0	6.0															

II Pattern II

(μF)	50/63VDC			100VDC			电容量 (μF)	50/63VDC			100VDC		
	W	H	T	W	H	T		W	H	T	W	H	T
0.10				7.2	6.5	2.5	0.39	7.2	7.5	3.5	7.2	9.5	4.5
0.12				7.2	6.5	2.5	0.47	7.2	7.5	3.5	7.2	10.0	5.0
0.15	7.2	6.5	2.5	7.2	7.5	3.5	0.56	7.2	9.5	4.5	7.2	10.0	5.0
0.18	7.2	6.5	2.5	7.2	7.5	3.5	0.68	7.2	9.5	4.5	7.2	11.0	6.0
0.22	7.2	6.5	2.5	7.2	7.5	3.5	0.82	7.2	9.5	4.5	7.2	11.0	6.0
0.27	7.2	6.5	2.5	7.2	9.5	4.5	1.0	7.2	10.0	5.0	7.2	11.0	6.0
0.33	7.2	7.5	3.5	7.2	9.5	4.5	1.5	7.2	11.0	6.0			

**FILM CAPACITOR
PART NUMBER CONFIGURATION**

