

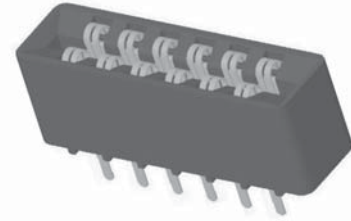

**.156" [3.96 mm] Contact Centers, .431" [10.95 mm] Insulator Height
Dip Solder/Eyelet/Right Angle**

SPECIFICATIONS

- Accommodates .062" ± .008" [1.57 ± .20] PC board
- Molded-in key available
- 3 amp current rating per contact
(for 5 amp application, consult factory)
- 30 milli ohm maximum at rated current



Sullins Edgecards

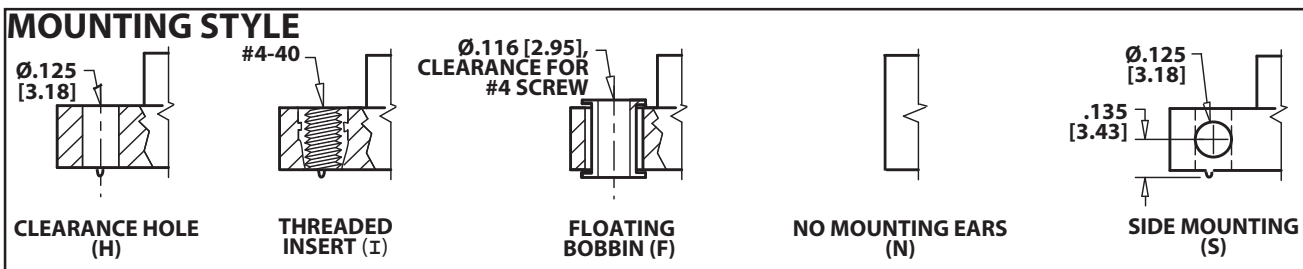
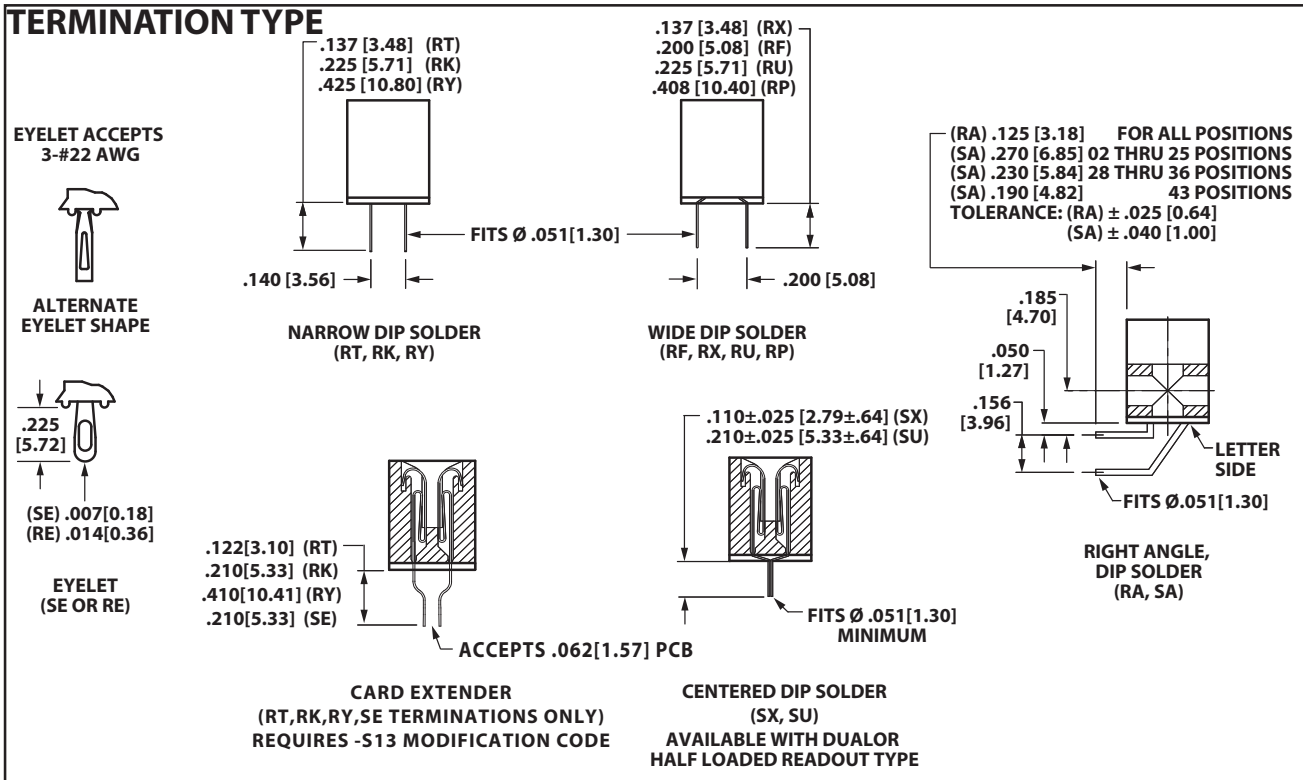
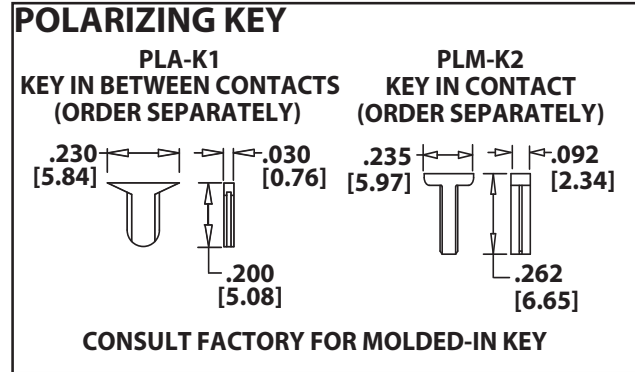
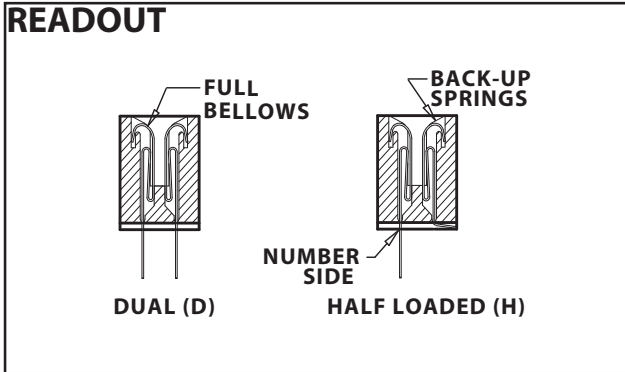



.156" [3.96 mm] Contact Centers, .431" [10.95 mm] Insulator Height Dip Solder/Eyelet/Right Angle

Sullins Edgecards

PART NUMBER CODING

MATERIALS (Insulator/Contact)

- E = PBT/Phosphor Bronze (Standard)
- R = PPS/Phosphor Bronze
- G = PA9T/Phosphor bronze
- H = PBT/Beryllium Copper
- A = PPS/Beryllium Copper
- J = PA9T/Beryllium Copper
- *F = PPS/Spinodal (Overall Gold Plating Only)
Consult Factory for Special Soldering Guidelines
- *C = PPS/Beryllium Nickel (Overall Gold Plating Only)
- *W = PEEK/Beryllium Nickel (Overall Gold Plating Only)
- *Consult Factory for availability.

CONTACT FINISH - RoHS Compliant
All platings are Lead Free and have .000050" Nickel underplate

	Contact Surface	Termination
B =	.000010" Gold	.000100" Pure Tin, Matte
C =	.000030" Gold	.000100" Pure Tin, Matte
G =	.000010" Gold	.000005" Gold
Y =	.000030" Gold	.000005" Gold
	Contact Surface	Overall Plating
S =	.000010" Gold	.000010" Gold
M =	.000030" Gold	.000010" Gold
E =	.000100" Pure Tin, Matte	.000100" Pure Tin, Matte

CONTACT CENTERS
M = .156" [3.96mm]

NUMBER OF CONTACT POSITIONS
See Chart Below

MODIFICATION CODE (Consult Factory)
OMIT FOR STANDARD
-S13 = Card Extender Accepts .062" [1.57] PCB (RT, RK, RY, SE Terminations Only)

MOUNTING STYLE (Opposite Page)
H = .125" [3.18mm] Clearance Holes
N = No Mounting
S = Side Mounting
I = Threaded Insert
F = Floating Bobbin

TERMINATION TYPE (Opposite Page)
RA = .125" Right Angle Dip Solder
SA = Long Right Angle Dip Solder
RT = .140" x .137" Dip Solder
RK = .140" x .225" Dip Solder
RY = .140" x .425" Dip Solder
RX = .200" x .137" Dip Solder
RF = .200" x .200" Dip Solder
RU = .200" x .225" Dip Solder
RP = .200" x .408" Dip Solder
SX = .110" [2.79mm] Centered Dip Solder
SU = .210" [5.33mm] Centered Dip Solder
SE = .007" [0.18mm] Thick Eyelet
RE = .014" [0.36mm] Thick Eyelet

READOUT (Opposite Page)
D = Dual
D = Dual Row/ Crimp to Center for Single Readout (SX, SU Termination Only)
H = Half Loaded

DIMENSIONS

Dimensions in [] are in millimeters, all others are in inches.

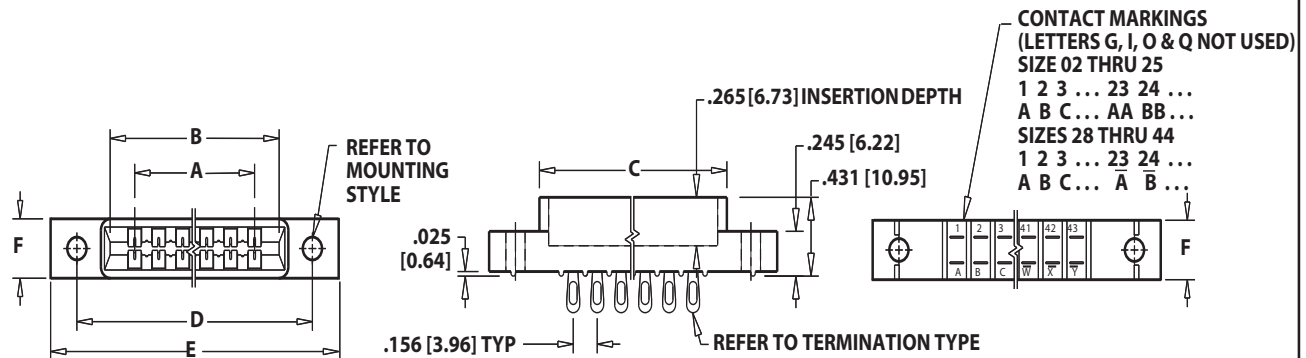

Tolerances with PPS Insulator Material may vary slightly due to shrinkage differential; Consult Factory.

POSITIONS/ CONTACTS	INCHES					[MILLIMETERS]						
	A±.008	B±.008	C±.015	D±.010	E MAX	F±.005	A±0.20	B±0.20	C±0.38	D±0.25	E MAX	F±0.13
02/04	0.156	0.476	0.596	'N' MOUNTING			3.96	12.09	15.14	'N' MOUNTING		
03/06	0.312	0.632	0.752	'N' MOUNTING			7.92	16.05	19.10	'N' MOUNTING		
06/12	0.780	1.100	1.220	1.533	1.902		19.81	27.94	30.99	38.94	48.31	
08/16	1.092	1.412	1.532	1.845	2.214		27.74	35.86	38.91	46.86	56.24	
10/20	1.404	1.724	1.844	2.157	2.526		35.66	43.79	46.84	54.79	64.16	
11/22	1.560	1.880	2.000	2.313	2.682		39.62	47.75	50.80	58.75	68.12	
12/24	1.716	2.036	2.156	2.469	2.838	0.325	43.59	51.71	54.76	62.71	72.09	
15/30	2.184	2.504	2.624	2.937	3.306		55.47	63.60	66.65	74.60	83.97	
18/36	2.652	2.972	3.092	3.405	3.774		67.36	75.49	78.54	86.49	95.86	
22/44	3.276	3.596	3.716	4.029	4.398		83.21	91.34	94.39	102.34	111.71	
24/48	3.588	3.908	4.028	4.341	4.710		91.14	99.26	102.31	110.26	119.63	
25/50	3.744	4.064	4.184	4.497	4.866		95.10	103.23	106.27	114.22	123.60	
28/56	4.212	4.532	4.652	4.965	5.334	0.438	106.98	115.11	118.16	126.11	135.48	
36/72	5.460	5.780	5.900	6.213	6.582		138.68	146.81	149.86	157.81	167.18	11.13
43/86	6.552	6.872	6.992	7.305	7.674	0.500	166.42	174.55	177.60	185.55	194.92	
44/88	6.708	7.028	7.148	7.461	7.830		170.38	178.51	181.56	189.51	198.88	12.70