

No.	LCY-12T09302A
Date	April. 24 th 2009

TECHNICAL LITERATURE
For
TFT-LCD Module

Model No. **LS013B4DN01**

Notice

The technical Literature is subject to change without any prior notice for the purpose of product improvement.
Please contact Sharp or its representative before designing your product based on this literature.

Mobile Liquid Crystal Display Group
SHARP CORPORATION

<<Precautions>>

NOTICE

○ These specification sheets are the proprietary product of SHARP CORPORATION ("SHARP") and include materials protected under copyright of SHARP. Do not reproduce or cause any third party to reproduce them in any form or by any means, electronic or mechanical, for any purpose, in whole or in part, without the express written permission of SHARP.

○ The application examples in these specification sheets are provided to explain the representative applications of the device and are not intended to guarantee any industrial property right or other rights or license you to use them. SHARP assumes no responsibility for any problems related to any industrial property right of a third party resulting from the use of the device.

○ SHARP reserves the right to make changes in the specifications, characteristics, data, materials, structures and other contents described herein at any time without notice in order to improve design or reliability. Contact SHARP in order to obtain the latest specification sheets before using any SHARP's device. Manufacturing locations are also subject to change without notice.

Observe the following points when in using any device in this publication. SHARP takes no responsibility for damage caused by improper use of the devices.

The devices in this publication are designed for use in general electronic equipment designs, such as:

- Personal computers ▪ Office automation ▪ Telecommunication equipment
- Test and measurement equipment ▪ Industrial control
- Audio visual and multimedia equipment ▪ Consumer electronics

The appropriate design measures should be taken to ensure reliability and safety when SHARP's devices are used for equipment such as:

- Transportation control and safety equipment(i.e.,aircraft,trains,automobiles,etc.)
- Traffic signals ▪ Gas leakage sensor breakers
- Alarm equipment ▪ Various safety devices etc.

○ SHARP's devices shall not be used for equipment that requires extremely high level of reliability, such as:

- Military and space applications ▪ Nuclear power control equipment
- Medical equipment for life support

○ SHARP assumes no responsibility for any damage resulting from the use of the device which does not comply with the instructions and the precautions specified in these specification sheets.

○ Contact and consult with a SHARP sales representative for any questions about this device.

[For handling and system design]

(1) It is recommended to handle LCD panel with carefully, since this LCD panel is made of thin glass, dropping the module or banging it against hard objects may cause cracks or fragmentation.

(2) Do not scratch the surface of the UV protection film as it is easily damaged.

(3) Water droplets on the UV protection film must be wiped off immediately as they may cause color changes, or other defects if remained for a long time.

(4) If the cleaning of the surface of the LCD panel is necessary, wipe it swiftly with cotton or other soft cloth.

Do not use organic solvents as it damages the UV protection film.

(5) Do not hold or touch the part of single glass of LCD panel which has electric connection area, as electric circuits in LCD panel may be damaged.

(6) Hold LCD with very carefully when placing LCD module into the system housing.

(7) LCD panel is susceptible to mechanical stress and even the slightest stress will cause a color change in background. So make sure the LCD panel is placed on flat plane without any continuous twisting, bending or pushing stress.

(8) When carrying the LCD module, place it on the tray to protect from mechanical damage. It is recommended to use the conductive trays to protect LCD panel from electrostatic discharge. Certain materials such as epoxy resin (amine's hardener) or silicone adhesive agent (de-alcohol or de-oxym) emits gas to which the UV protection film reacts (color change).

Check carefully that gas from materials used in system housing or packaging do not hart the UV protection film.

(9) Do not apply excessive stress or pressure to LCD module. Do not to use chloroprene rubber as it may affect on the reliability of the electrical interconnection.

(10) As this LCD module contains components sensitive to electrostatic discharge, more than 200V, be sure to follow the instructions in below.

① Operators

Operators must wear anti-static wears to prevent electrostatic charge up to and discharge from human body.

② Equipment and containers

Process equipment such as conveyer, soldering iron, working bench and containers may possibly generate electrostatic charge up and discharge. Equipment must be grounded through 100Mohms resistance. Use ion blower.

③ Floor

Floor is an important part to leak static electricity which is generated from human body or equipment.

There is a possibility that the static electricity is charged to them without leakage in case of insulating floor, so the electrostatic earth should be lower than the $1 \times 10^8 \Omega$.

④ Humidity

Proper humidity of working room may reduce the risk of electrostatic charge up and discharge. Humidity should be kept over 50% all the time.

⑤ Transportation/storage

Storage materials must be anti-static to prevent causing electrostatic discharge.

⑥ Others

(11) Protective film is attached on the surface of the UV protection film on LCD panel to prevent scratches or other damages.

When removing this protective film, remove it slowly under proper anti-ESD control such as ion blower.

[For operating LCD module]

- (1) Do not operate the LCD panel under outside of electrical specification. Otherwise LCD panel may be damaged.
- (2) Do not operate the LCD panel under outside of specified driving timing chart. Otherwise LCD panel may not have proper picture quality.
- (3) A still image should be displayed less than two hours, if it is necessary to display still image longer than two hour, display image data must be refreshed in order to avoid sticking image on LCD panel.

[Precautions for Storage]

- (1) Do not expose the LCD module to direct sunlight or strong ultraviolet light for long periods. Store in a dark place.
- (2) The liquid crystal material will solidify if stored below the rated storage temperature and will become an isotropic liquid if stored above the rated storage temperature, and may not retain its original properties. Only store the module at normal temperature and humidity ($25 \pm 5^{\circ}\text{C}$, $60 \pm 10\% \text{RH}$) in order to avoid exposing the UV protection film to chronic humidity.

(3) Keeping Method

a. Don't keeping under the direct sunlight.

b. Keeping in the tray under the dark place.

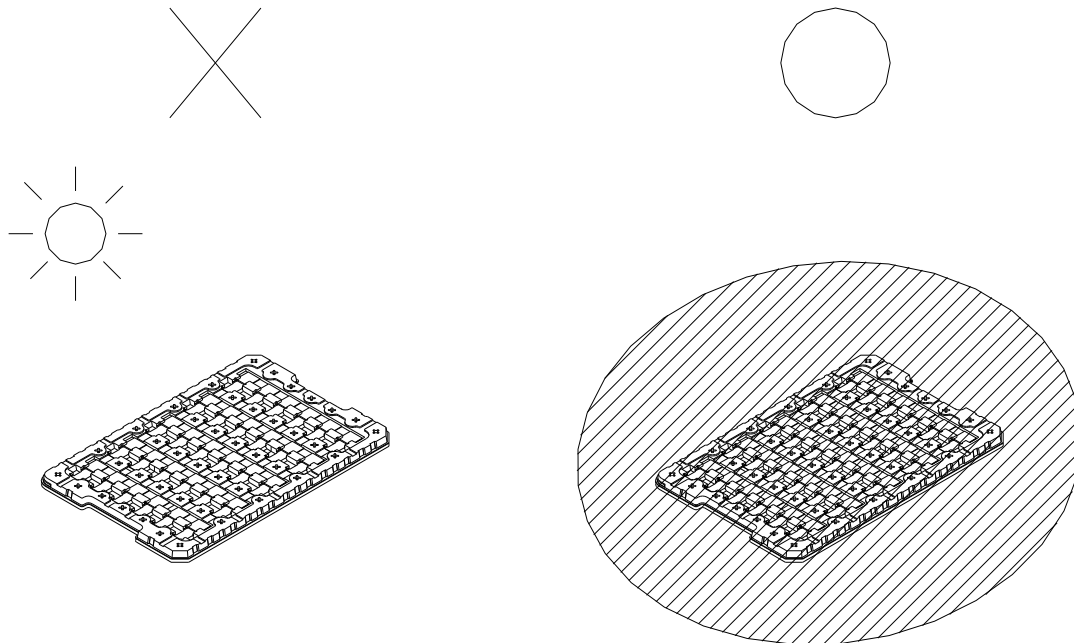

[Other Notice]

- (1) Do not operate or store the LCD module under outside of specified environmental conditions.
- (2) As electrical impedance of power supply lines (VDD-VSS) are low when LCD module is working, place the de-coupling capacitor near by LCD module as close as possible.
- (3) Although the LCD panel has the UV protection film on the LCD panel surface, just in case, do not expose the LCD module to direct sunlight or strong ultraviolet light for long periods.
- (4) Do not disassemble the LCD module as it may cause permanent damage.
- (5) Since the liquid crystal is injurious, do not put it into the eyes or mouth. When liquid crystal sticks to hands, feet or clothes, wash it out immediately with soap.
- (6) This LCD module does not contain nor use any ODS (1,1,1-Trichloroethane, CCL4) in all materials used, in all production processes.
- (7) Observe all other precautionary requirements in handling general electronic components.

[Precautions for Discarding Liquid Crystal Modules]

LCD panel: Dispose of as glass waste. This LCD module contains no harmful substances. The liquid crystal panel contains no dangerous or harmful substances. The liquid crystal panel only contains an extremely small amount of liquid crystal (approx.100mg) and therefore it will not leak even if the panel should break.

-Its median lethal dose (LD50) is greater than 2,000 mg/kg and a mutagenetic (Aims test: negative) material is employed.

Contents

1. Outline	P6
2. Characteristics	P6
3. Mechanical Specification	P6
4. Input terminal specification	P7
5. Absolute Maximum Rating	P8
6. Electrical Specification	P8
7. Optical Characteristics	P18
8. LCD Module Outline Dimensions	P20
9. External capacitor	P21
10. External power supply	P22
11. Zebra Connector	P23
12. Packaging	P24
13. Reliability test	P26

1.Outline

This TFT-LCD module is a reflective active matrix memory liquid crystal display module with CG silicone thin film transistor.

Module outline is indicated in Table 8-1.

2.Characteristics

- Reflective panel of white and black with aspect ratio of 1:1
- 1.35" screen has 96x 96 resolution.(9216 pixels stripe array)
- Display control by serial data signal communication.
- Arbitrary line data renewable.
- 1bit internal memory for data storage within the panel.
- Thin, light-weight and compact module with monolithic technology.
- Super low power consumption TFT panel.
- Zebra connecter

3. Mechanical Specification

Table 3-1

Item	Specification	unit
Screen size	1.35	Inch
Viewing Area	24 (H) × 24 (V)	mm
Dot configuration	96 (H) × 96 (V)	Dot
Dot pitch	0.252 (H) × 0.252 (V)	mm
Pixel Array	Stripe Array	-
Outline Dimension	28.2 (W) × 32.34 (H) × 1.4 (D)	mm
Mass	3.6 (TYP)	g
Surface Hardness	3H	Pencil hardness

(Note) Detail dimension and tolerance are shown in fig. 8-1

4. Input terminal names and functions

Table4-1

Terminal	Symbol	I/O	Function	Remark
1	TEST1	-	Test terminal	【Remark4-1】
2	TEST2	-	Test terminal	【Remark4-1】
3	SCLK	INPUT	Serial clock signal	
4	SI	INPUT	Serial Data input signal	
5	SCS	INPUT	Chip select signal	
6	EXTCOMIN	INPUT	External COM inversion signal input (H: enable)	
7	DISP	INPUT	Display ON/OFF signal	【Remark4-3】
8	VDDA	POWER	Power supply (Analog)	
9	VDD	POWER	Power supply (Digital)	
10	EXTMODE	INPUT	COM inversion select terminal	【Remark4-2】
11	VSS	POWER	GND(Digital)	
12	VSSA	POWER	GND(Analog)	
13	TEST3	-	Test terminal	【Remark4-1】
14	TEST4	-	Test terminal	【Remark4-1】

【Remark4-1】TEST terminal: OPEN these test terminals.

【Remark4-2】When it's "H", EXTCOMIN signal is enable. And when it's "L", serial input flag is enable.

"H" mode; connect the EXTMODE to VDD, "L" mode; connect the EXTMODE to VSS.

【Remark4-3】The display ON/OFF signal is only for display. Data in the memory will be saved at the time of ON/OFF.

When it's "H", data in the memory will display, when it's "L", white color will display and data in the memory will be saved.

4-2) Recommended circuit;

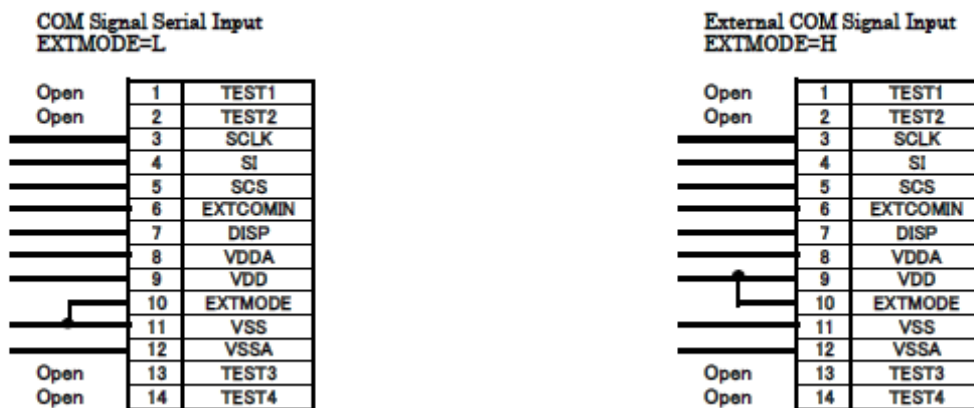

5. Absolute maximum rating

Table5-1 (GND=0V)

Item		Symbol	MIN.	MAX.	Unit	Remark
Power supply voltage	Analog	VDDA	-0.3	+5.8	V	
	Logic	VDD	-0.3	+5.8	V	[Remark5-1]
Input signal voltage(high)				VDD	V	[Remark5-2]
Input signal voltage(low)			-0.3		V	
Storage Temperature		Tstg	-30	+80	°C	[Remark5-3,4]
Operation Temperature (at panel surface)		Topr1	-20	+70	°C	[Remark5-5]

[Remark5-1] Applies to EXTMODE.

[Remark5-2] Applies to SCLK, SI, SCS, DISP, EXTCOMIN.

[Remark5-3] Do not exceed this temperature in any parts of module.

[Remark5-4] Maximum wet bulb temperature is 57°C or lower. No condensation is allowed.

Condensation will cause electrical leak and may cause the module to not meet this specification.

[Remark5-5] Operating temperature is the temperature that guarantees only the operation.

For contrast, response time, and other display quality determination, use Ta= +25°C.

6. Electrical characteristics

6-1) TFT LCD panel Drive

Table6-1 Recommended operating Condition

VSS(GND)=0V、Ta= +25°C

Item		symbol	MIN.	TYP.	MAX.	Unit	Remark
Power supply	Analog	VDDA	+4.8	+5.0	+5.5	V	
	Logic	VDD	+4.8	+5.0	+5.5	V	[Remark6-1]
Input signal voltage	Hi	VIH	+2.70	+3.00	※VDD	V	[Remark6-2]
	Lo	VIL	VSS	VSS	VSS+0.15	V	
Input leak current	Hi	IOH	-	-	TBD	uA	[Remark6-2] VI=3V
	Lo	IOL	-	-	TBD	uA	[Remark6-2] VI=0V

※ Lower 3V is recommended, and it's lower than the VDD voltage.

[Remark6-1] Applies to EXTMODE="H"

[Remark6-2] Applies to SCLK, SI, SCS, DISP, EXTCOMIN.

6-2) Power supply sequence

[On sequence] * All on start up System

- ① 5V start up
- ② Initializes memory data within pixel
Initialize with D2 "all clear flag" or display all white. T2 : more than 1V
- ③ To cancel latch initialization for TCOM. T3 : more than 30us
The period of canceling COM latch circuit for initialization by using DISP signal.
- ④ TCOM polarity initialization T4: more than 30us
The period of initialization for TCOM polarity by EXTCOMIN signal.

[Normal operation]

Duration of normal driving.

[Off sequence]

- ⑤ Initializes memory data within pixel T5 : more than 1V
- ⑥ The period of initialization for VA, VB, and VCOM T6 : more than 1V
- ⑦ 5V shut down

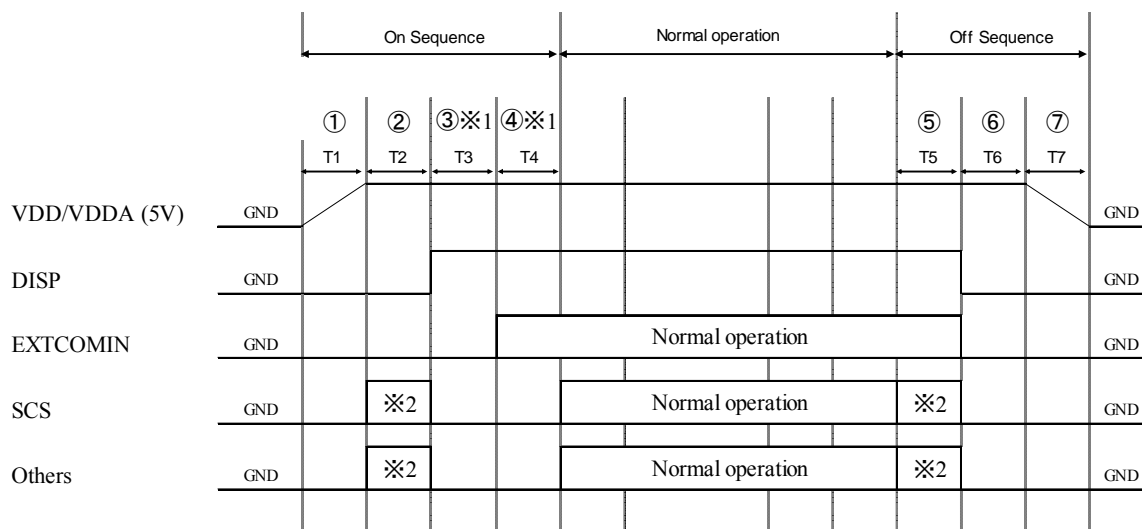

※Detail description for signal timing is shown the digital timing chart and the AC timing chart.

※1 The order of ③ and ④ can be set as being reversed, in this case, TCOM polarity inversion timing which can be controlled by EXTCOMIN doesn't work during DISP="L".

※2 Setup value for initialization of data within pixel memory
To refer the timing chart of all clear mode section 6-5-4.

[Remark] Precautions at the time of power on and power off.

Remark 1) When power on, VDD and VDDA are same time or VDD should be faster than the VDDA.

Remark 2) When power off, VDD and VDDA are same time or VDDA should be faster than the VDD.

6-3) Input signal characteristics

Table6-3-1

VDDA=+5.0V、VDD=+5.0V、GND=0V、Ta=25°C

Item	Symbol	MIN	TYP	MAX	Unit	Remark
Frame frequency	fSCS	1	-	60	Hz	
Clock frequency	fSCLK		1	2	MHz	
Vertical Interval	tV	16.66	-	1000	ms	
COM Frequency	fCOM	0.5	-	30	Hz	

Table 6-3-2

VDDA=+5.0V、VDD=+5.0V、GND=0V、Ta=25°C

Item	Symbol	MIN	TYP	MAX	Unit	Remark
SCS Rising time	trSCS	-	-	50	ns	
SCS Falling Time	tfSCS	-	-	50	ns	
SCS High duration	twSCSH	68	-	-	us	[Remark 6-4]
		12	-	-	us	[Remark 6-5]
SCS Low duration	twSCSL	(1)	-	-	us	
SCS set up time	tsSCS	(3)	-	-	us	
SCS hold time	thSCS	(1)	-	-	us	
SI frequency	fSI	-	0.5	1	MHz	
SI Rising time	trSI	-	-	50	ns	
SI Folling time	tfSI	-	-	50	ns	
SI set up time	tsSI	(120)	-	-	ns	
SI hold time	thSI	(125)	-	-	ns	
SCLK Rising time	trSCLK	-	-	50	ns	
SCLK Folling time	tfSCLK	-	-	50	ns	
SCLK High duration	twSCLKH	200	450	-	ns	
SCLK Low duration	twSCLKL	200	450	-	ns	
EXTCOMIN signal freequency	fEXTCOMIN		1	60	Hz	[Remark6-6]
EXTCOMIN signal rising time	trEXTCOMIN	-	-	50	ns	
EXTCOMIN signal folling time	tfEXTCOMIN	-	-	50	ns	
EXTCOMIN signalHigh duration	thlEXTCOMIN	1			us	
DISP Rising time	trDISP	-	-	50	ns	
DISP Folling time	tfDISP	-	-	50	ns	

() is tentative valure.

[Remark6-4] Data renew mode.

[Remark6-5] Display mode.

[Remark6-6] Adjust EXTCOMIN frequency to be lower than the frame frequency.

SCS, SI, SCLK Signal

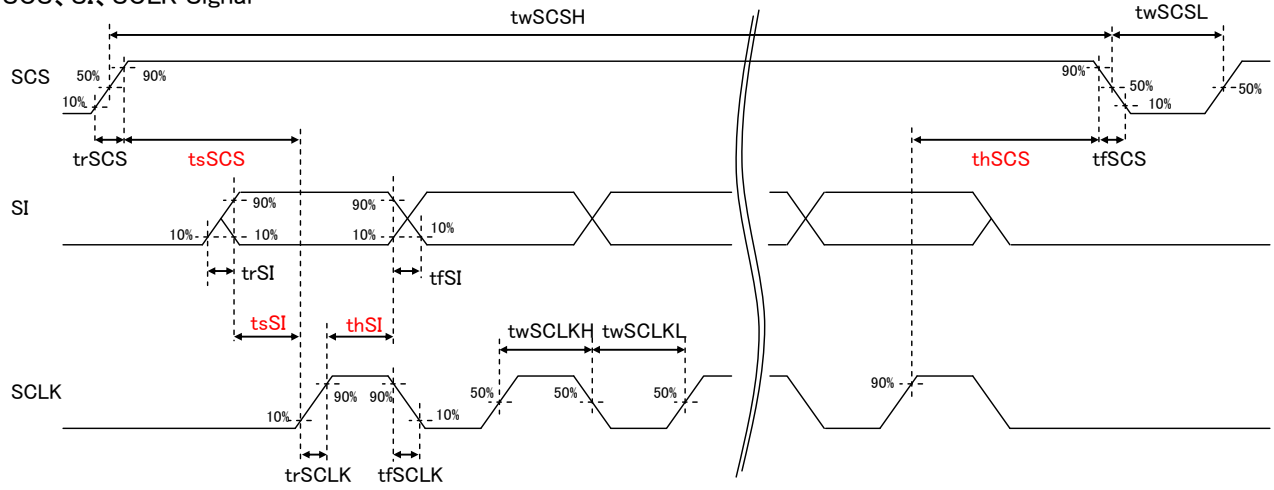

EXTCOMIN Signal

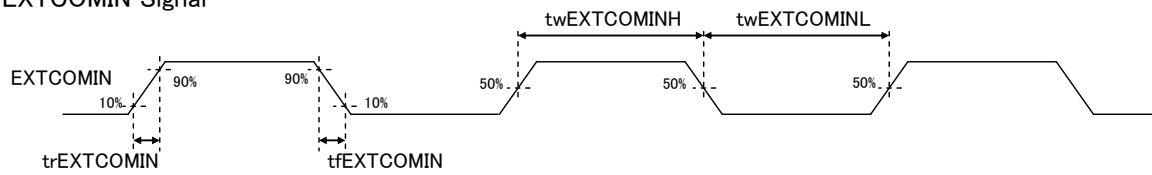

DISP Signal

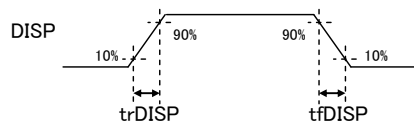

※SCS,SI,SCLK、DISP: 3V Amplitude
EXTCOMIN : 5V amplitude.

6-4) Power consumption (Average)

Table6-4

Ta=25°C

Item	Symbol	MIN	TYP	MAX	unit	Remark
Condition1			15		uW	[Remark6-6]
Condition2			30		uW	[Remark6-6]

* Condition1

Display mode (No display data update)

Common AC Driving with VDD=5V, VDDA=5V, fSCLK=1MHz, fSCS= 1 Hz, Display pattern: Vertical stripe display

* Condition 2

Data Renew mode (With display data update: 1Hz)

Common AC Driving with VDD=5V, VDDA=5V, fSCLK=1MHz, fSCS= 1 Hz, Display pattern: Vertical stripe display

[Remark6-6] This is the average power in normal condition, not the peak power for COM driving.

Allow margin in power supply. Use of capacitor is recommended for VDD+VDDA.

(If VDD and VDDA are separate, use of capacitor on each is recommended.)

6-5) Input Signal Timing Chart

6-5-1 Data Renew Mode (1 line)

Renews data on one specified line. (M0="H", M2="L")

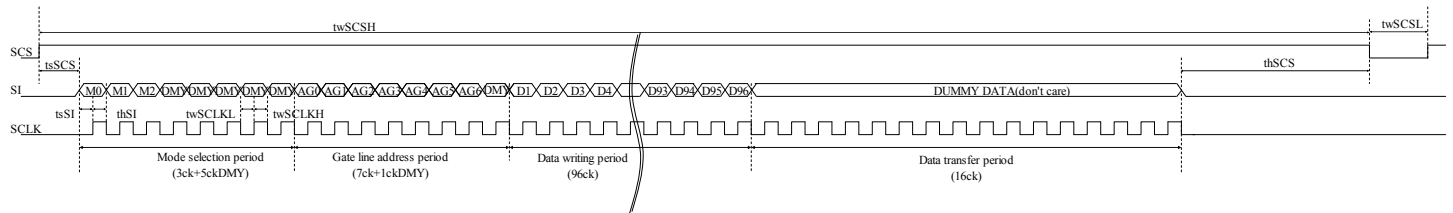

- M0: Mode flag: If M0 is "H". -> Data refresh mode "Pixel data will be updated". If M0 is "L" -> Display mode "Pixel data is held."
- M1: LC polarity inversion flag: If M1 is "H" then VCOM="H" is output. If M1 is "L" then VCOM="L" is output. In addition, if EXTMODE is set as "H", M1 set value doesn't matter.
- M2: All flags are cleared. If M2 is "L" then all flags are cleared.
When all clear are needed, refer to "all clear timing chart"
- D1 - D96: Display data: If D* is "L" then Black display can be appeared, if D* is "H" then White display can be appeared
- DUMMY DATA: Dummy data. Don't care but "L" is recommended

※In terms of Data writing period
Data has been stored in 1st latch block of Binary driver on Panel.

※In term of Data transfer period
The data which has been stored in 1st latch block is transferred to pixel memory.

Renews data on one specified line. (M0="H", M2="L")

※Refer to 6-6) Input Signal and Display for gate line address setting.

※M1: Frame inversion flag is enabled when EXTMODE="L".

※When SCS becomes L, M0 and M2 are cleared.

※In renew mode (When M2="H") do "All Clear", and set P1 through P96 as L.

6-5-2 Data Renew Mode

Updates multiple line data. (M0="H", M2="L")

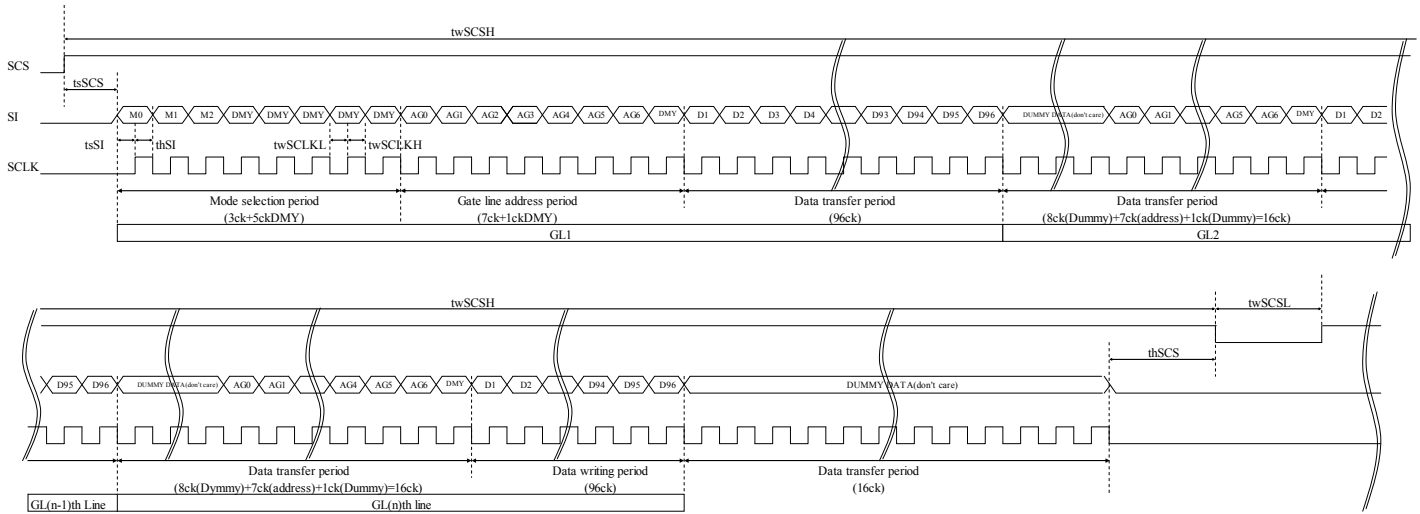

- M0: Mode flag: If M0 is "H" then Data refresh mode "Pixel data will be updated, If M0 is "L" then display mode "Pixel data is held"
- M1: LC polarity inversion flag: If M1 is "H" then VCOM="H" is output. If M1 is "L" then VCOM="L" is output.
In addition, if EXTMODE is set as "H", M1 set value doesn't matter.
- M2: All flags are cleared. If M2 is L then all flags are cleared.
When all clear are needed, refer to "all clear timing chart"
- D1 - D96: Display data: If D* is "L" then Black display can be appeared, if D* is "H" then White display can be appeared
- DUMMY DATA: Dummy data. Don't care but "L" is recommended

※In terms of Data writing period

Data has been stored in 1st latch block of Binary driver on Panel.

※In term of Data transfer period

As an example, the 1st latch block in binary driver which stored the data of 1st gate line"GL1"output the data to GL1 and store the data for 2nd gate line"GL2" at same time.

※Refer to 6-6) Input Signal and Display for gate line address setting.

※Input data continuously.

※M1: Frame inversion flag is enabled when EXTMODE="L".

※When SCS becomes L, M0 and M2 are cleared.

※In renew mode (When M2="H") do "All Clear", and set P1 through P96 as L.

6-5-3 Display mode

Maintains data in the memory(Maitain the current display)(M0="L", M2="L")

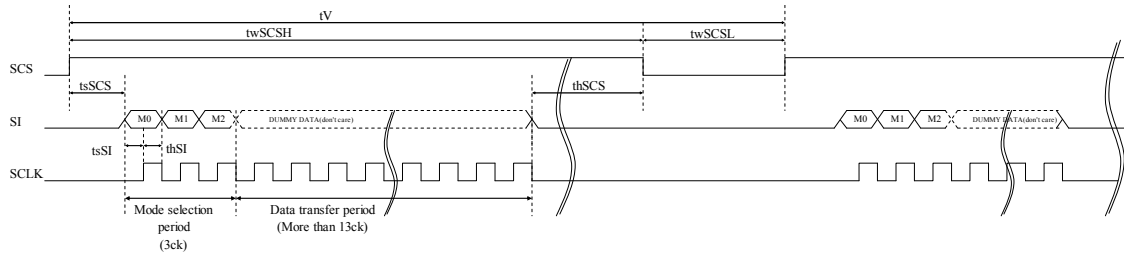

- M0: Mode flag: If M0 is "L" then display mode "Pixel data is held",
If M0 is "H" then Data refresh mode "Pixel data will be updated.
- M1: LC polarity inversion flag: If M1 is "H" then VCOM="H" is output.
If M1 is "L" then VCOM="L" is output.
In addition, if EXTMODE is set as "H", M1 set value doesn't matter.
- M2: All flags are cleared. If M2 is L then all flags are cleared.
When all clear are needed, refer to "all clear timing chart"
- DUMMY DATA: Dummy data. Don't care but "L" is recommended

※M1: Frame inversion flag is enabled when EXTMODE="L".

※When SCS becomes L, M0 and M2 are cleared.

6-5-4 All Clear mode

Clear data in the pixel and the memory data and displays white color. (M0="L", M2="H")

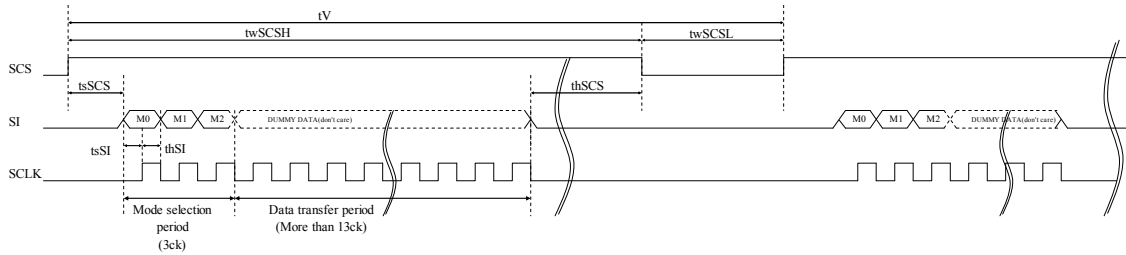

- M0: Mode flag: If M0 is "L" then display mode "Pixel data is held",
If M0 is "H" then Data refresh mode "Pixel data will be updated.
- M1: LC polarity inversion flag: If M1 is "H" then VCOM="H" is output.
If M1 is "L" then VCOM="L" is output.
In addition, if EXTMODE is set as "H", M1 set value doesn't matter.
- M2: All flags are cleared. If M2 is L then all flags are cleared.
When all clear are needed, refer to "all clear timing chart"
- DUMMY DATA: Dummy data. Don't care but "L" is recommended

※M1: Frame inversion flag is enabled when EXTMODE="L".

※When SCS becomes L, M0 and M2 are cleared.

6-5-5 COM Inversion

There are two signals, one is COM signal with serial Input(EXTMODE="L") and other is external COM signal input (EXTMODE="H").

EXTMODE="L"

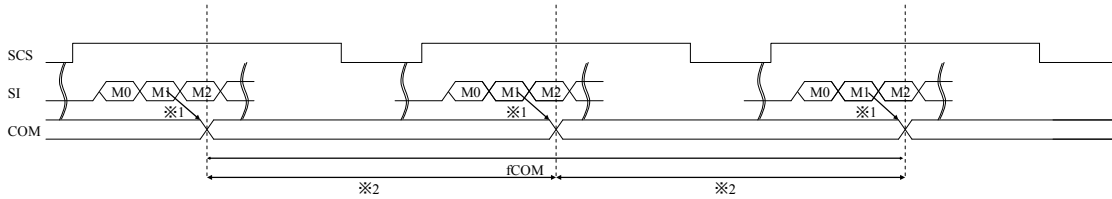

- M1: LC polarity inversion flag: If M1 is "H" then VCOM="H" is output. If M1 is "L" then VCOM="L" is output.
- ※1: LC inversion has been changed by M1 flag statement.
- ※2: The periods of plus polarity and minus polarity should be same length as much as possible.

EXTMODE="H"

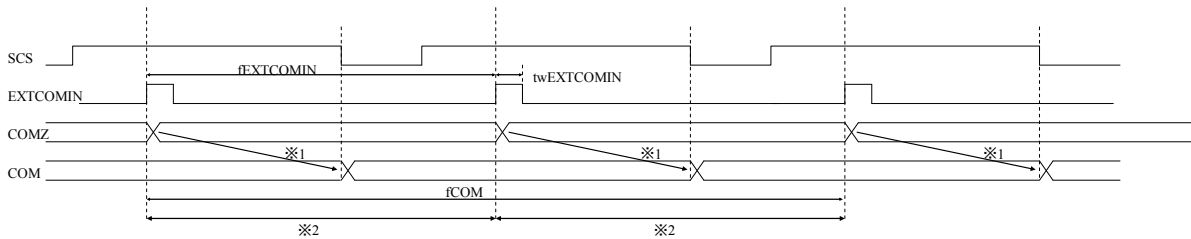

- ※1: LC inversion polarity has been set by the rising timing of EXTCOMIN in internal circuit block as COMZ signal, and when SCS become falling timing, LC inversion has been activated as COM signal.
- ※2: The period of EXTCOMIN should be constant.

Truth table of COM

<EXTMODE="L">

EXTCOMIN	COM
L	Depend on status of M1
L	
H	
H	

<EXTMODE="H">

EXTCOMIN	COMZ	
	高电平	低电平
L	L	L
L	H	H
H	L	H
H	H	L

In rising timing of EXTMODE, internal signal "COMZ" is inverted.

COMZ	COM	
	SCS="L"	SCS="H"
L	L	Qn-1
H	H	Qn-1

※Qn-1: COM has been changed polarity when SCS meet falling edge.

(COMZ status has been fixed by signal SCS)

6-6) Input Signal and Display, Gate address(Line) Setting

Data position in display[H,V]

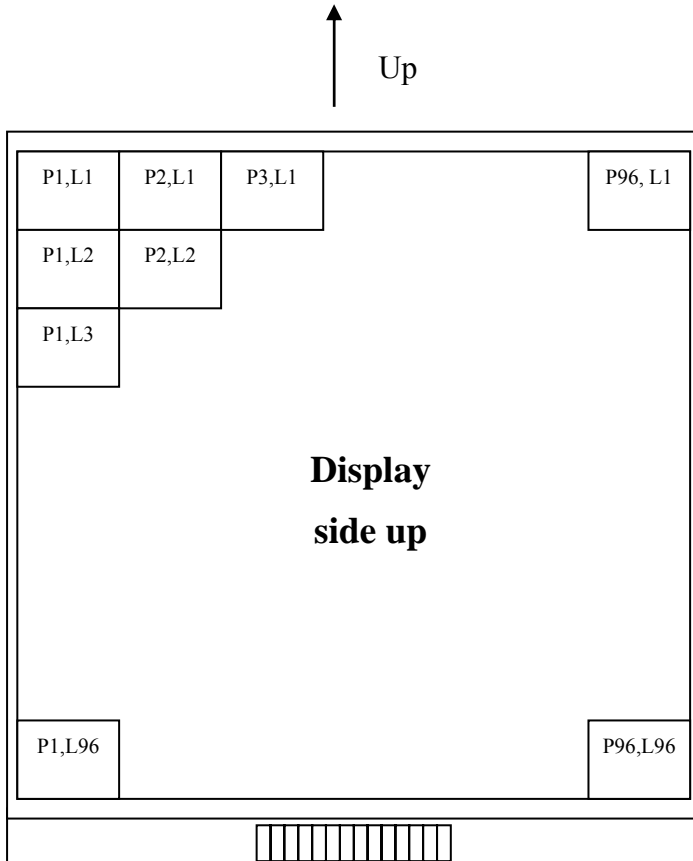

Line	Gate line address setting						
	AG0	AG1	AG2	AG3	AG4	AG5	AG6
L1	H	L	L	L	L	L	L
L2	L	H	L	L	L	L	L
L3	H	H	L	L	L	L	L
.
.
.
L94	L	H	H	H	H	L	H
L95	H	H	H	H	H	L	H
L96	L	L	L	L	L	H	H

7. Optical characteristics

Table 7-1

Ta=25°C

Item	Symbol	MIN.	TYP.	MAX.	unit	Remark
Viewing angle CR≥5	H	θ21,θ22		TBD	°(degree)	[Remark7-1]
	V	θ11		TBD	°(degree)	
		θ12		TBD	°(degree)	
Contrast ratio	CR.	5	10			[Remark7-2, 3]
Reflecivity ratio	R		50		%	[remark7-3]
Response time	Rise	τr		50	ms	[Remark 7-3,4]
	Fall	τd		50	ms	
Panel Chromaticity	White	x		0.313		[Remark7-3]
		y		0.338		

[Remark7-3] Optical characteristics measurement equipment.

Figure 7-2 is for contrast ratio, reflectivity ratio, and panel chromaticity measurement, and figure 7-3 is for response time measurement. Both are to be conducted in a dark or room equipment to a dark room

Measurement equipment (CM-2002)

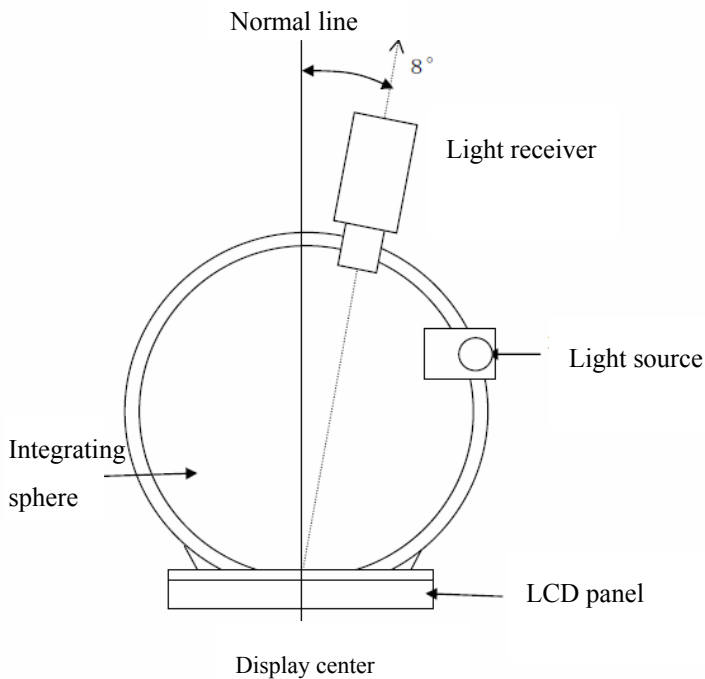

Measurement equipment (LCD-5200)

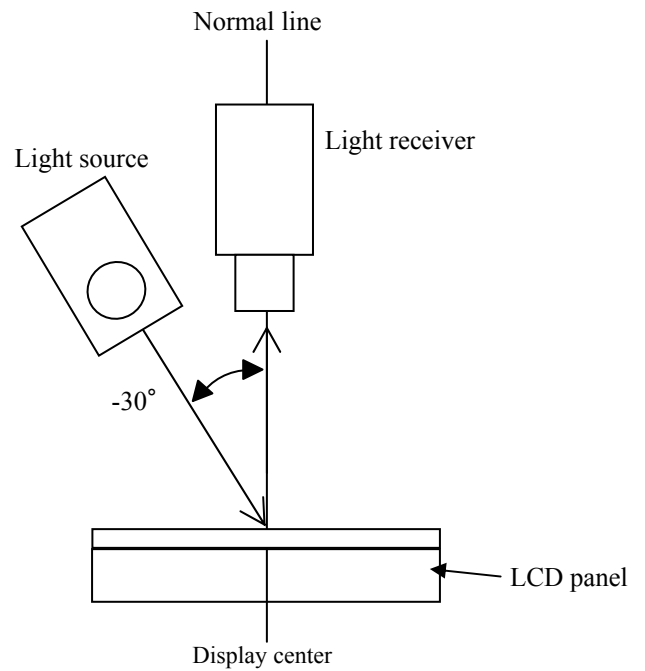
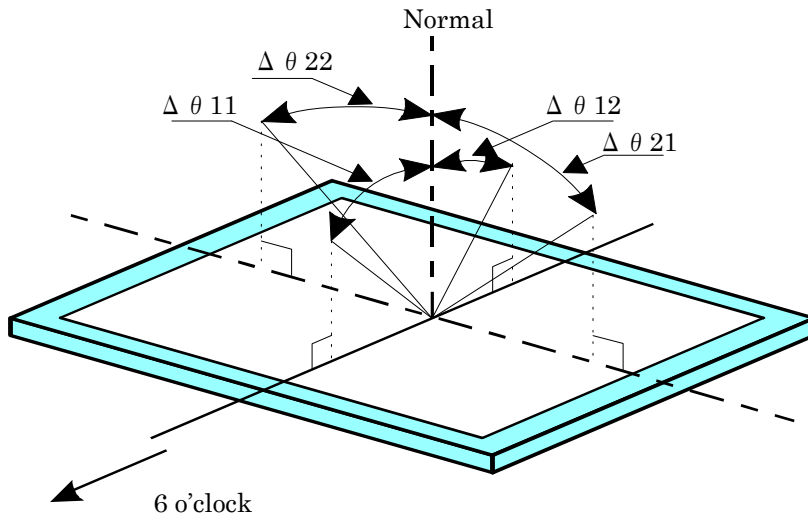

Fig7-2 Contrast ratio, Reflection ratio, Panel chromaticity of white

Fig7-3 response time

[Remark7-1] Defintion of Viewint Angle



[Remark7-2] Defintion of Contrast Retio

$$\text{Contrast ratio(CR)} = \frac{\text{Reflection intensity in white display}}{\text{Reflection intensity in black display}}$$

[Remark7-4] Respons time (Change in reflection ratio)

It's difined by the time change of optical receiver output when signal is input to display white or black

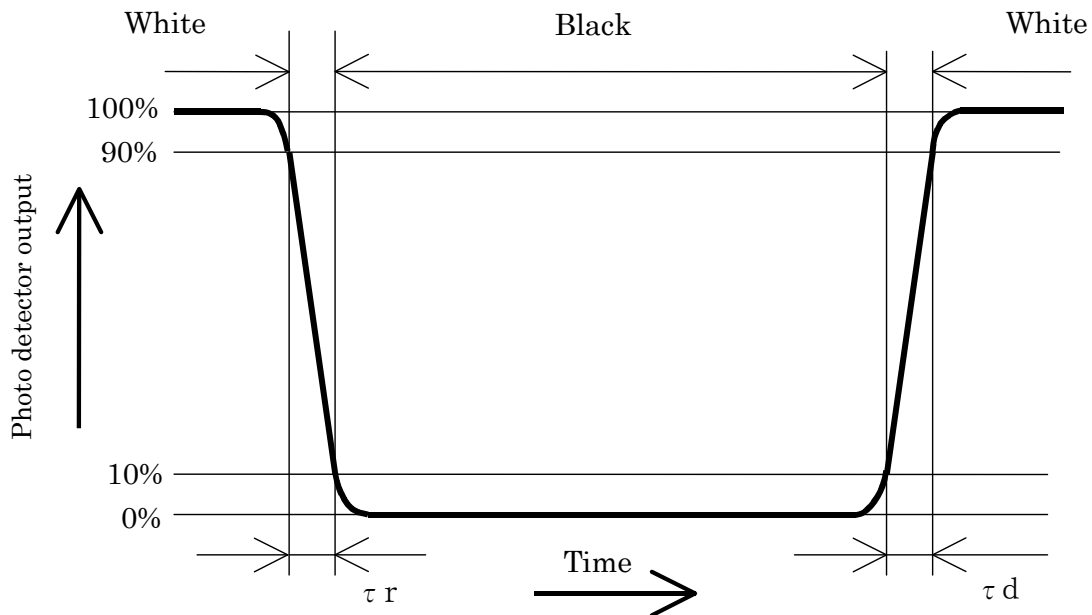

8. Module outline

1.35 Inch (96×96) Monochromatic zebra connector specifications external form drawing

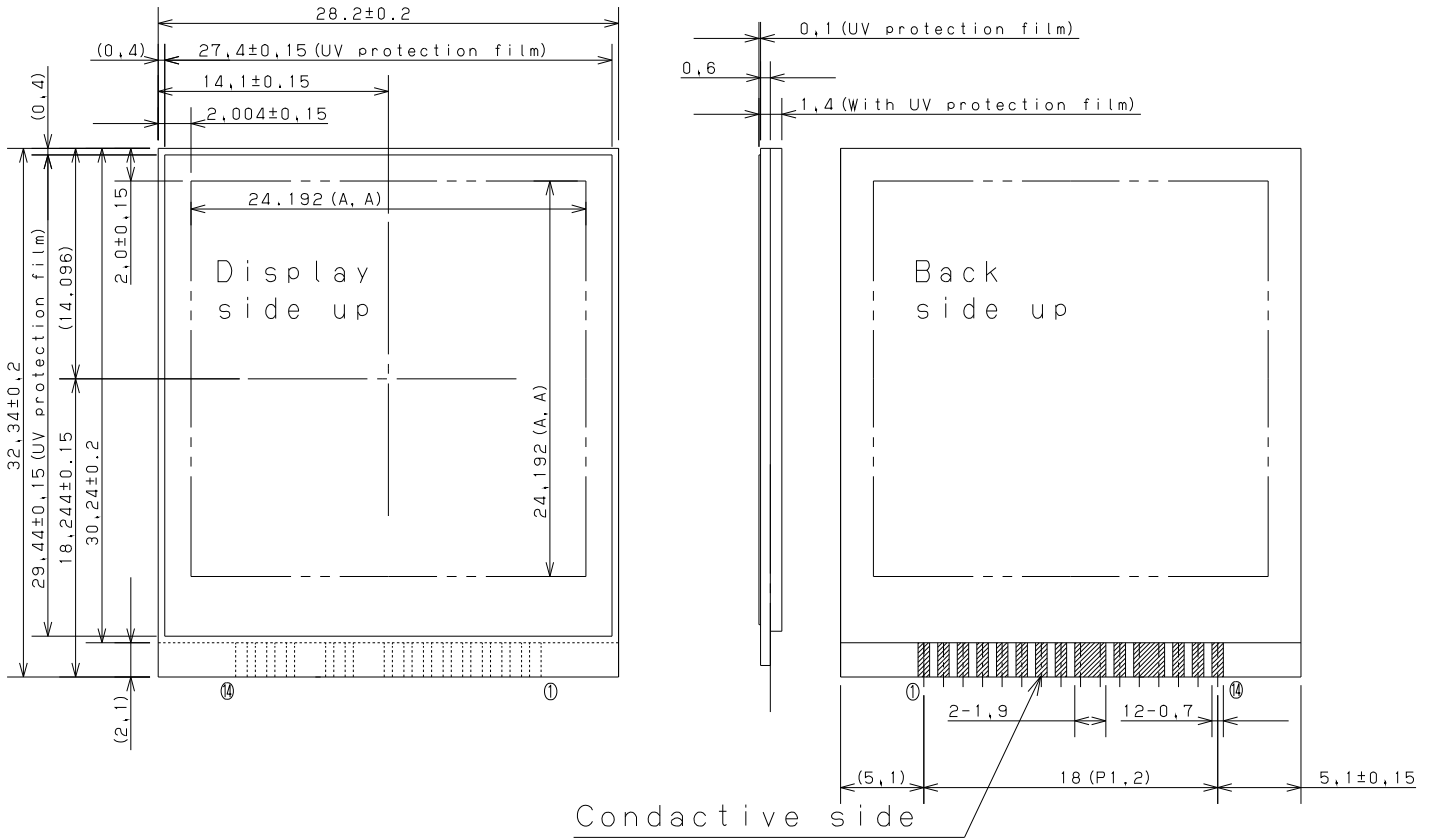

Fig8-1

terminal enlarged picture

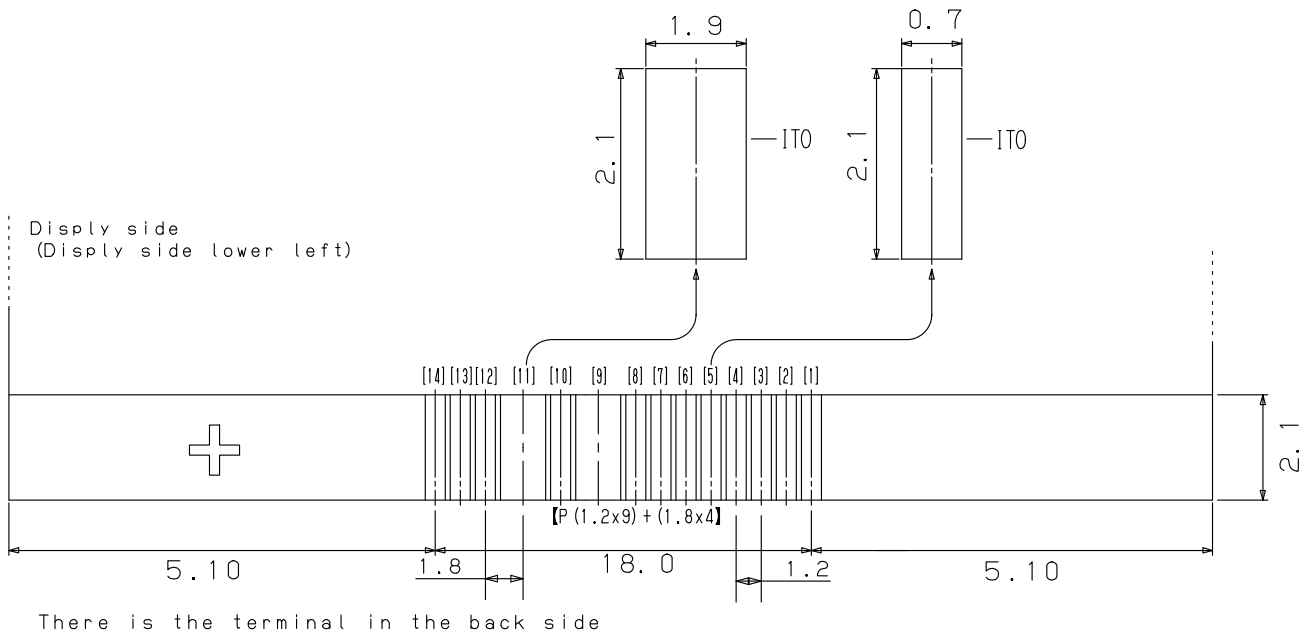

Fig 8-2

9. External capacitor

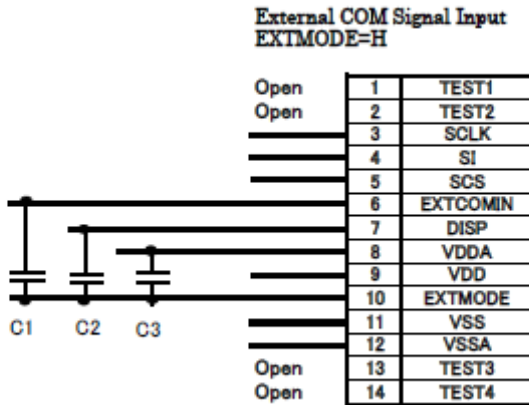

Fig.9-1 External capacitor recommendation capacity value

<Recommended capacity value>

- C1: DISP- VSS: rank B 0.1uF Ceramic capacitor
- C2: VDDA- VSS: rank B 1uF Ceramic capacitor
- C3: VDD- VSS: rank B 1uF Ceramic capacitor

[Remark] The recommendation capacity of an external capacitor is shown. Finally, determine a capacity value after performing evaluation sufficient by your system. (More bigger capacity value is selectable.)

10. External Power Supply Circuit

10-1 An external power supply circuit is necessary to drive the Pixel Memory LCD with the 3V battery.

Table 1-1 shows power supply IC of the recommendation.

Table 1-1

Maker	Model Number	Note
SII	S-8821	Charge pump type
National Semiconductor	LM2750	Charge pump type

Refer to specifications of each power supply IC for a detailed specification.

Set the constant value after it evaluating it sufficiently by an actual application when you use it.

10-2. Electrical specification

Table 2-1

Model Number	Vin [V]		Vout			Iout [A]
	min	max	min	typ	max	
S-8821	2.8	5.0	4.9	5.0	5.1	0.04
LM2750	2.7	5.6	4.8	5.0	5.2	0.04

Refer to specifications of each power supply IC for a detailed specification.

Set the constant value after it evaluating it sufficiently by an actual application when you use it.

10-3. Reference circuit

The reference circuit is shown below.

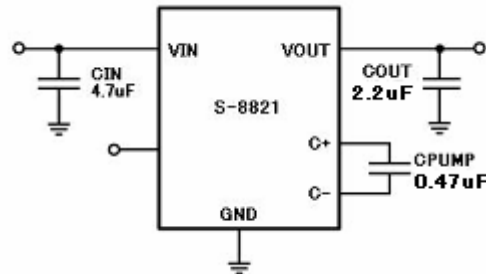

S-8821

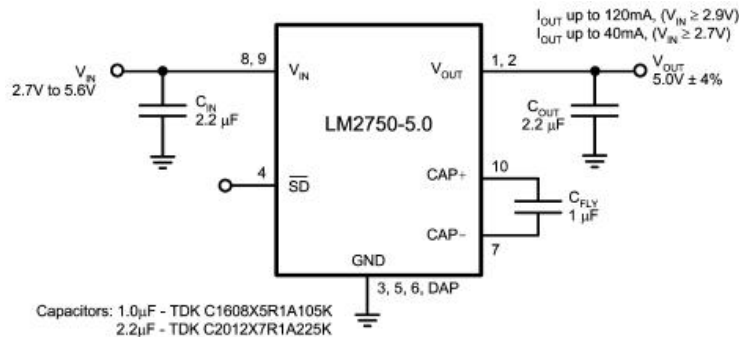

LM2750

11. Zebra connector

Contact Resistance : lower than 20Ω

【Recommended zebra connector】

- Please select one from these two types.

① Shin-Etsu Polymer: MS-G type

Recommended size L:27.7±0.25mm W:1.8±0.1mm H:2.3±0.1mm P:0.1mm

② Shin-Etsu Polymer: GB-U type

Recommended size L:27.3±0.6mm W:1.7±0.2mm H:2.3±0.2mm P:0.1mm

The zebra connector placement position

1. MS-G Specifications (A figure of reference)

2. GB-U Specifications (A figure of reference)



Fig 11-1

Fig11-2

12. Packaging

12-1) Serial number .(ink-jet print)

Show an indication point in a figure of external form dimensions of fig 12-1.

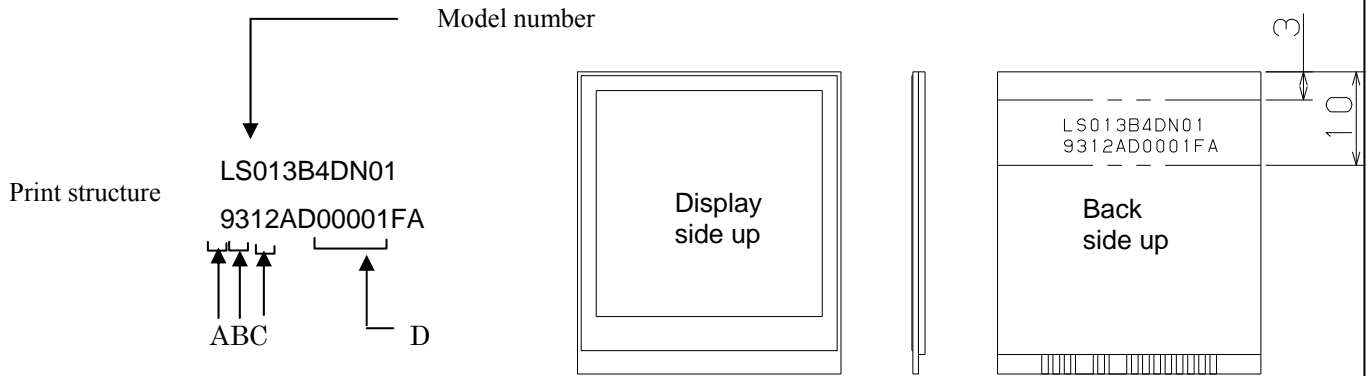

Serial number specifications

- A : a single figure of the year
- B : month(1,2....9,X,Y,Z)
- C : day
- D : serial number

Fig 12-1 Serial number print position

12-2) Forwarding form

① Piling number of cartons : Max 12

Package quality in a carton: 1,000pcs

② Conditions for storage.

- Temperature: 0~40°C
- Humidity: 60%RH or less (at 40°C) No dew condensation at low temperature and high humidity.
- Atmosphere: Harmful gas, such as acid or alkali which bites electronic components and/or wires, must not be detected.
- Period : about 3 months
- Opening of the package : In order to prevent the LCD module from breakdown by electrostatic charge, please control the room humidity over 50%RH and open the package taking sufficient countermeasures against electrostatic charges, such as earth, etc.

12-3) Packaging

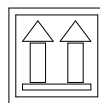
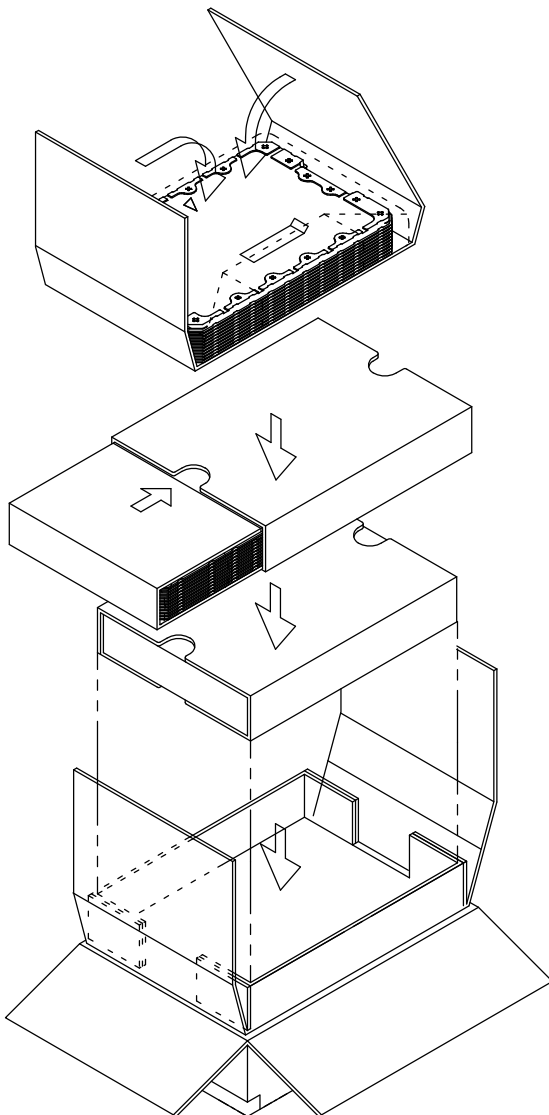

FRAGILE
取扱注意

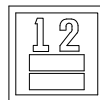

SHARP®
Electronic Components

TYPE		社内品番: (4S) LS013B4DN01
QUANTITY		LotNO. : (1T) 2009. xx. xx
LOT (DATE)		Quantity: (Q) 1000 PCS
		ユーザー品番 : _____
		シャープ物流用ラベルです。 () ()

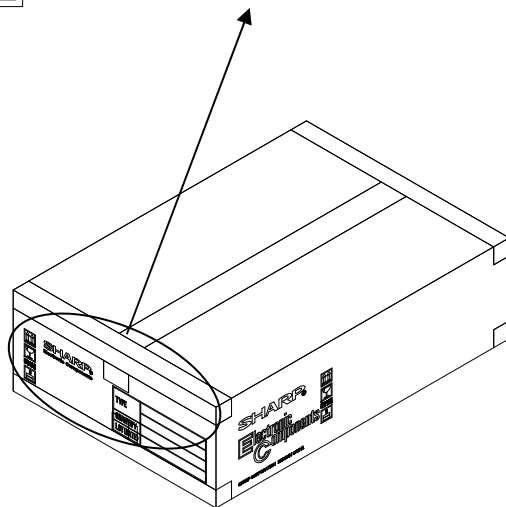

fig 12-2 Package Form

13. Reliability Test Conditions

13-1 Reliability test items

Table13-1

	Test Item	Test condition	Remark
1	High temperature storage test	Ta=80°C 240h	
2	Low temperature storage test	Ta=35°C 240h	
3	High temperature and high humidity operating test	Tp=40°C/95%RH 240h	
4	High temperature operating test	Tp=70°C 240h	
5	Low temperature operating test	Tp=-20°C 240h	
6	Shock test	Ta=-30°C(1h)~+80°C(1h) / 5 cycle	
7	Electro static discharge test	±200V、200pF(0Ω) each terminal: 1 time	

[Remark] Ta = Ambient temperature, Tp = Panel temperature

[Check items] In the standard condition, there shall be no practical problems that may affect the display function.

13-2 Panel surface stress specification

Panel surface stress specification has been defined as a parameter "Force of stress [N]" without no picture failer.

Load testing: Minimum 120[N]

Test condition :

Test structure : LCD panel with UV protection film
 Press point : Center of LCD panel
 Press Jig : φ10mm column
 Press speed : 1mm/minute
 Support : fixed on stage

Press time : 5 seconds after achievement of the press strength, then releas it.