

## Thick Film Chip Resistor



Chip resistors, which are available for surface mounting, are general passive component which is useful for voltage drop, current controlling in circuit and surface mounting is available.

Samsung electro-mechanics also manufactures a wide range of chip resistors such as general, precision, trimmable and low ohms and so on.

Production is increasing with demand for small size & light weight of set product. We provide ultra-small, high-reliability, high-stability resistors. We have obtained ISO-9002/QS-9000 and ISO-14001 certification.

### General Features

- Very small, thin, and light weight.
- Both flow and reflow soldering are applicable.
- Owing to the reduced lead inductance, the high frequency characteristic is excellent.
- Suitable size and packaging for surface mount assembly.
- Reel type and Bulk type Packaging are applicable.

### Applications

- General purpose.
- Home Appliances  
(DVD, Digital TV, Camcorder, VTR, Digital Camera, Audio, Tuner)
- For Computers & Communication Device.  
(Notebook, Memory Module, Mobile, Network Equipment, etc)

### Part Numbering

<b>RC</b>	<b>1005</b>	<b>J</b>	<b>101</b>	<b>CS</b>
①	②	③	④	⑤

#### ① CODE DESIGNATION

RC : This code expresses the Resistor that is produced by Samsung Electro-Mechanics CO.LTD. (with the exception of Trimmable Chip Resistor(RT))

## 2 DIMENSION

The dimension is expressed as a 4 digit number base on SI unit (mm). <Table 1>  
First 2 digits are length of resistor, and last 2 digits are width. <Fig 1>

<Fig 1>

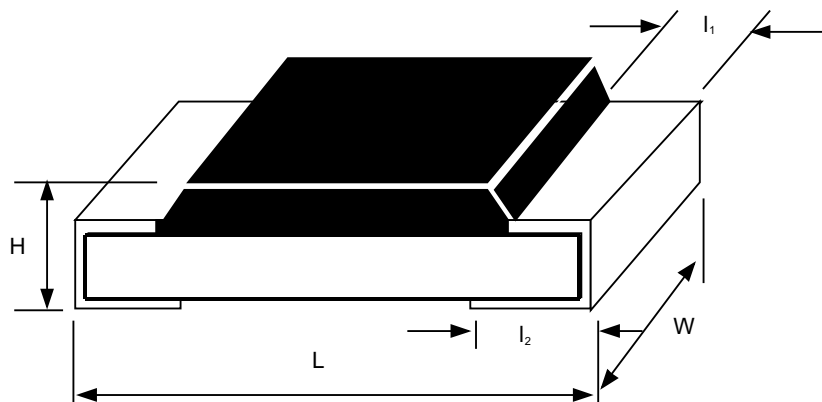

<Table 1>

[ Unit : mm ]

Dimension	(inch)	L	W	H	l <sub>1</sub>	l <sub>2</sub>
*0402	(01005)	0.40±0.02	0.20±0.02	0.12±0.03	0.15±0.03	0.15±0.03
0603	(0201)	0.60±0.03	0.30±0.03	0.23±0.03	0.10±0.05	0.15±0.05
1005	(0402)	1.00±0.05	0.50±0.05	0.35±0.05	0.20±0.10	0.25±0.10
1608	(0603)	1.60 ± 0.10	0.80 ± 0.15	0.45 ± 0.10	0.30 ± 0.20	0.35 ± 0.10
2012	(0805)	2.00 ± 0.20	1.25 ± 0.15	0.50 ± 0.10	0.40 ± 0.20	0.35 ± 0.20
3216	(1206)	3.20 ± 0.20	1.60 ± 0.15	0.55 ± 0.10	0.45 ± 0.20	0.40 ± 0.20
3225	(1210)	3.20 ± 0.20	2.55 ± 0.20	0.55 ± 0.10	0.45 ± 0.20	0.40 ± 0.20
5025	(2010)	5.00 ± 0.20	2.50 ± 0.20	0.55 ± 0.10	0.60 ± 0.20	0.60 ± 0.20
6432	(2512)	6.30 ± 0.20	3.20 ± 0.20	0.55 ± 0.10	0.60 ± 0.20	0.60 ± 0.20

\* New : under developing('06)

## 3 RESISTANCE TOLERANCE

The Resistance Tolerance is expressed as a letter base on EIAJ standard. <Table 2>

<Table 2>

Item	F	G	J	K	M
Tolerance (%)	± 1	± 2	± 5	± 10	± 20
Producing Series	E-24, E-96	E-48	E-24	E-12	E-6
Type	P, L	G, L	G, L	G, L, T	T

※ Type Representation : G(General), P(Precision), L(Low ohms), T(Trimmable)

#### ④ NOMINAL RESISTANCE VALUE

The Nominal Resistance Value is expressed as 3 or 4 digits base on EIAJ standard.<Table 3>

<Table 3>

Item	3 Digits mark	4 Digits mark
Resistance Tolerance	F, G, J, K, M	F, G
Only number	First 2 digits : Resistance value Last 1 digit : Exponential number of 10.	First 3 digits : Resistance value Last 1 digit : Exponential number of 10.
Number & alphabet "R"	Read alphabet "R" as decimal point.	Read alphabet "R" as decimal point.
Example	1) 101 : $10 \times 10^1 = 10 \times 10 = 100\Omega$ 2) 7R5 : $7.5 = 7.5\Omega$ 3) R75 : $0.75\Omega$	1) 1001 : $100 \times 10^1 = 100 \times 10 = 1 \text{ k}\Omega$ 2) 9R09 : $9.09 = 9.09\Omega$

If resistance value in E-96 is same resistance value in E-24, we mark 3 or 4 digits.

In case of JUMPER(0 ohm), '000' is marked on that resistor.

※ 0603, 1005, 1608 (4 digits mark) : No Marking on the resistor.

#### ⑤ PACKAGING CODE

The Packaging Code is expressed as 2 digits alphabet. <Table 4>

<Table 4>

Packaging Code	Description	Dimension	Packaging Q'ty
C S	7" REEL PACKAGING	0603	15,000 PCS
		1005	10,000 PCS
		1608, 2012, 3216, 3225	5,000 PCS
		5025, 6432	4,000 PCS
E S	10" REEL PACKAGING	1608, 2012, 3216	10,000 PCS
A S	13" REEL PACKAGING	1005	40,000 PCS
		1608, 2012, 3216, 3225	20,000 PCS
		5025, 6432	15,000 PCS
G S	BULK CASE PACKAGING	1608	25,000 PCS
		2012	10,000 PCS
		3216	5,000 PCS

## CARACTERISTIC LINE UP

### ● RESISTANCE RANGE

The Resistance Range that we produce depends on the Dimension and the Resistance Tolerance of the resistor. <Table 16>

<Table 16>

[ unit : Ω ]

Dim. Tol.	*0402 (01005)	0603 (0201)	1005 (0402)	1608 (0603)	2012 (0805)	3216 (1206)	3225 (1210)	5025 (2010)	6432 (2512)	Type
	F	10~1M	10~1M	10~1M	10~1M	10~1M	10~1M	10~1M	10~1M	
		*0.07~1	0.2~1	0.2~1	0.1~1	0.1~1	0.1~1	0.047~1	0.039~1	L
G	10~1M	10~1M	10~1M	1~1M	1~1M	1~1M	1~1M	1~1M	1~1M	G
		*0.07~1	0.047~1	0.1~1	0.1~1	0.07~1	0.1~1	0.1~1	0.1~1	L
J	10~1M	1~10M	1~10M	1~10M	1~10M	1~10M	1~10M	1~10M	1~10M	G
		*0.07~1	0.047~1	0.1~1	0.1~1	0.07~1	0.1~1	0.1~1	0.1~1	L
K		1~10M	1~10M	1~10M	1~10M	1~10M	1~10M	1~10M	1~10M	G
		-	0.047~1	0.1~1	0.1~1	0.07~1	0.1~1	0.1~1	0.1~1	L
		-	-	1~10M	1~10M	1~10M	1~10M	1~10M	1~10M	T
M		-	-	1~10M	1~10M	1~10M	1~10M	1~10M	1~10M	T

\* New : under developing ( '06)

※ Type Representation : G(General), P(Precision), L(Low ohms), T(Trimmable)

## CARACTERISTIC LINE UP

### ● RATED POWER

The Rated Power is classified by the dimension of the resistor. <Table 17>

<Table 17>

Dimension item	0603 (0201)	1005 (0402)	1608 (0603)	2012 (0805)	3216 (1206)	3225 (1210)	5025 (2010)	6432 (2512)
Rated Power	1/20 W (0.05 W)	1/16 W (0.063 W)	1/10 W (0.100 W)	1/8 W (0.125 W)	1/4 W (0.25 W)	1/3 W (0.33 W)	2/3 W (0.67W)	1.0 W
Working Volt(Max)	25 V	50 V	50 V	150 V	200 V	200 V	200 V	200 V
STOL, IOL Volt(Max)	50 V	100 V	100 V	300 V	400 V	400 V	400 V	400 V

※ The rated power is specified as continuous full loading power at the ambient temperature of  $70\pm 2^{\circ}\text{C}$ . In case of the temperature exceeding  $70\pm 2^{\circ}\text{C}$ , the power should be derated in accordance to <Fig 17>.

<Fig 17>

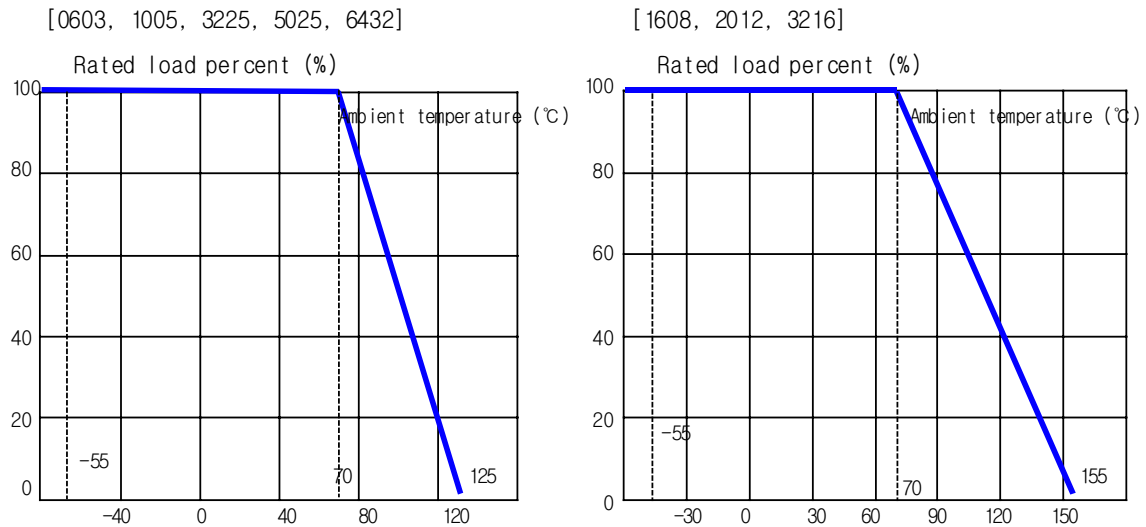

#### ▶ Working Temperature

- 55 °C ~ + 125 °C : 0603, 1005, 3225, 5025, 6432

- 55 °C ~ + 155 °C : 1608, 2012, 3216

## RELIABILITY TEST CONDITION

Jumper's reliability test data are only applied to General type resistor.

### ● ELECTRICAL CHARACTERISTIC

The electrical characteristic test should satisfy the test method, procedure, and standard.

If there is no special comment, each test is performed at standard conditions.

(temperature 20℃, humidity 65%RH, pressure 1023mbar)

item	Permissible deviation		Test method																														
	Resistor	Jumper																															
DC resistance	DC resistance value should be within the specified resistance tolerance.	50mΩ Maximum	<ul style="list-style-type: none"> <li>Standard : JIS C 5201-1 4.5</li> <li>Test voltage : &lt;Table 8&gt;</li> <li>Applying time : within 5 seconds.</li> <li>Test board : &lt;Fig 11&gt;</li> </ul> <table border="1"> <caption>&lt;Table 8&gt;</caption> <thead> <tr> <th>Range (Ω)</th> <th>Voltage (V)</th> </tr> </thead> <tbody> <tr> <td>R &lt; 1</td> <td>0.1</td> </tr> <tr> <td>R &lt; 10</td> <td>0.1</td> </tr> <tr> <td>10 ≤ R &lt; 100</td> <td>0.3</td> </tr> <tr> <td>100 ≤ R &lt; 1K</td> <td>1.0</td> </tr> <tr> <td>1K ≤ R &lt; 10K</td> <td>3.0</td> </tr> <tr> <td>10K ≤ R &lt; 100K</td> <td>10</td> </tr> <tr> <td>100K ≤ R &lt; 1M</td> <td>25</td> </tr> <tr> <td>1M ≤ R</td> <td>50</td> </tr> </tbody> </table>	Range (Ω)	Voltage (V)	R < 1	0.1	R < 10	0.1	10 ≤ R < 100	0.3	100 ≤ R < 1K	1.0	1K ≤ R < 10K	3.0	10K ≤ R < 100K	10	100K ≤ R < 1M	25	1M ≤ R	50												
Range (Ω)	Voltage (V)																																
R < 1	0.1																																
R < 10	0.1																																
10 ≤ R < 100	0.3																																
100 ≤ R < 1K	1.0																																
1K ≤ R < 10K	3.0																																
10K ≤ R < 100K	10																																
100K ≤ R < 1M	25																																
1M ≤ R	50																																
Temperature Coefficient of Resistance	<table border="1"> <thead> <tr> <th>Tolerance</th> <th>ppm/℃</th> <th>Type</th> </tr> </thead> <tbody> <tr> <td rowspan="2">F</td> <td>100</td> <td>P</td> </tr> <tr> <td>200</td> <td>L</td> </tr> <tr> <td>G</td> <td>Table 9</td> <td>G, P, L</td> </tr> <tr> <td>J</td> <td>Table 9</td> <td>G, L</td> </tr> <tr> <td>K</td> <td>Table 9</td> <td>G, L</td> </tr> <tr> <td>M</td> <td>Table 9</td> <td>G, L, T</td> </tr> </tbody> </table> <p>&lt;Table 9&gt;</p> <table border="1"> <thead> <tr> <th>Range(Ω)</th> <th>ppm/℃</th> </tr> </thead> <tbody> <tr> <td>0.1 ≤ R &lt; 1</td> <td>+600, -300</td> </tr> <tr> <td>1 ≤ R &lt; 10</td> <td>±500</td> </tr> <tr> <td>10 ≤ R &lt; 1M</td> <td>±200</td> </tr> <tr> <td>1M ≤ R &lt; 10M</td> <td>±300</td> </tr> </tbody> </table>	Tolerance	ppm/℃	Type	F	100	P	200	L	G	Table 9	G, P, L	J	Table 9	G, L	K	Table 9	G, L	M	Table 9	G, L, T	Range(Ω)	ppm/℃	0.1 ≤ R < 1	+600, -300	1 ≤ R < 10	±500	10 ≤ R < 1M	±200	1M ≤ R < 10M	±300	-	<ul style="list-style-type: none"> <li>Standard : JIS C 5201-1 4.8</li> <li>Temp. : 20℃ → -55℃ → 20℃ → 125℃ → 20℃</li> <li>Test board : &lt;Fig 11&gt;</li> <li>Calculation : <math display="block">TCR(ppm/℃) = \frac{R - R_0}{R_0} \times \frac{1}{T - T_0} \times 10^6</math></li> <li>T<sub>0</sub> : 20 ± 2℃</li> <li>R<sub>0</sub> : Resistance at T<sub>0</sub> (Ω)</li> <li>T : Test temperature ( -55, 125℃)</li> <li>R : Resistance at T (Ω)</li> </ul>
Tolerance	ppm/℃	Type																															
F	100	P																															
	200	L																															
G	Table 9	G, P, L																															
J	Table 9	G, L																															
K	Table 9	G, L																															
M	Table 9	G, L, T																															
Range(Ω)	ppm/℃																																
0.1 ≤ R < 1	+600, -300																																
1 ≤ R < 10	±500																																
10 ≤ R < 1M	±200																																
1M ≤ R < 10M	±300																																
Short time overload (STOL)	<ol style="list-style-type: none"> <li>No mechanical damage</li> <li>ΔR should be within ±(1%+0.1Ω)</li> </ol>	50mΩ Maximum	<ul style="list-style-type: none"> <li>Standard : JIS C 5201-1 4.13</li> <li>Test voltage : 2.5 times of rated voltage Max. surge current at the Jumper.</li> <li>Applying time : 5 seconds</li> <li>Test board : &lt;Fig 11&gt;</li> </ul>																														
Intermittent overload (IOL)	<ol style="list-style-type: none"> <li>No mechanical damage</li> <li>ΔR should be within ±(3%+0.1Ω)</li> </ol>	50mΩ Maximum	<ul style="list-style-type: none"> <li>Standard : JIS C 5201-1 4.13</li> <li>Test voltage : 2.5 times of rated voltage Max. surge current at the Jumper.</li> <li>Test method : 1 sec ON, 25 sec OFF 10,000<sup>+400</sup>cycles</li> <li>Test board : &lt;Fig 11&gt;</li> </ul>																														

item	Permissible deviation		Test method														
	Resistor	Jumper															
Withstanding voltage	<ul style="list-style-type: none"> <li>No mechanical damage, short circuit, or disconnection.</li> </ul>	Same as left	<ul style="list-style-type: none"> <li>Standard : JIS C 5201-1 4.7</li> <li>Test voltage : 0603,1005,1608 AC 100V, others AC 500V</li> <li>Applying time : 60 +10/-0 seconds</li> <li>Test board : &lt;Fig 13&gt;</li> </ul>														
Insulation resistance	<ul style="list-style-type: none"> <li>Should have more than 1,000MΩ</li> </ul>	Same as left	<ul style="list-style-type: none"> <li>Standard : JIS C 5201- 4.7</li> <li>Test voltage : 0603,1005,1608 DC 100V, others DC 500V</li> <li>Applying time : 60 seconds</li> <li>Test pressure : 1.0±0.2 N</li> <li>Test board : &lt;Fig 13&gt;</li> </ul>														
Noise	<ul style="list-style-type: none"> <li>Noise standard &lt;Table 10&gt;</li> </ul> <table border="1"> <thead> <tr> <th>Range (Ω)</th> <th>dB Max.</th> </tr> </thead> <tbody> <tr> <td>0.1 ≤ R &lt; 1</td> <td>-10(L-Type)</td> </tr> <tr> <td>1 ≤ R &lt; 100</td> <td>-10</td> </tr> <tr> <td>100 ≤ R &lt; 1K</td> <td>0</td> </tr> <tr> <td>1K ≤ R &lt; 100K</td> <td>15</td> </tr> <tr> <td>100K ≤ R &lt; 1M</td> <td>20</td> </tr> <tr> <td>1M ≤ R &lt; 10M</td> <td>30</td> </tr> </tbody> </table>	Range (Ω)	dB Max.	0.1 ≤ R < 1	-10(L-Type)	1 ≤ R < 100	-10	100 ≤ R < 1K	0	1K ≤ R < 100K	15	100K ≤ R < 1M	20	1M ≤ R < 10M	30	-	<ul style="list-style-type: none"> <li>Measure equipment : QUAN-TECH NOISE METER (MODEL 315C)</li> </ul>
Range (Ω)	dB Max.																
0.1 ≤ R < 1	-10(L-Type)																
1 ≤ R < 100	-10																
100 ≤ R < 1K	0																
1K ≤ R < 100K	15																
100K ≤ R < 1M	20																
1M ≤ R < 10M	30																

## ● MECHANICAL CHARACTERISTIC

The mechanical characteristic test should satisfy the test method, procedure, and standard. If there is no special comment, each test is performed at standard conditions. (temperature 20°C, humidity 65%RH, pressure 1023mbar)

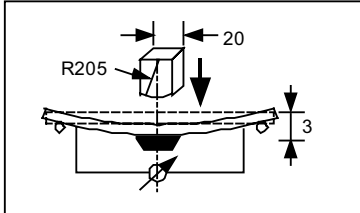
item	Permissible deviation		Test method
	Resistor	Jumper	
Solderability	<ul style="list-style-type: none"> <li>New solder coated more than 95% of termination</li> </ul>	Same as left	<ul style="list-style-type: none"> <li>Standard : JIS C 5201-1 4.17</li> <li>Test temperature : 245 ± 5°C</li> <li>Test time : 3 ± 0.5 sec (dipping both side)</li> </ul>
Bending strength	<ol style="list-style-type: none"> <li>No mechanical damage</li> <li>ΔR should be within ±(0.5%+0.05Ω)</li> </ol>	Same as left	<ul style="list-style-type: none"> <li>Standard : JIS C 5201-1 4.33</li> <li>Test board : &lt;Fig 12&gt;</li> <li>Test speed : 100mm/min</li> <li>Test procedure : press until 3mm, then keep 5 seconds &lt;Fig 14&gt;</li> </ul> <p>&lt;Fig 14&gt;</p> 

item	Permissible deviation		Test method
	Resistor	Jumper	
Termination strength	<ul style="list-style-type: none"> <li>No mechanical damage, or sign of disconnection</li> </ul>	Same as left	<ul style="list-style-type: none"> <li>Standard : JIS C 5201-1 4.16</li> <li>Test time : applying pressure for 10 seconds</li> <li>Test tension : 0603,1005,1608 - 3N (300g · f) Others (500g · f)</li> </ul>
Withstanding soldering heat	<ol style="list-style-type: none"> <li>No mechanical damage</li> <li><math>\Delta R</math> should be within <math>\pm(1\%+0.05\Omega)</math></li> </ol>	50m $\Omega$ Maximum	<ul style="list-style-type: none"> <li>Standard : JIS C 5201-1 4.18</li> <li>Temperature : 260 <math>\pm</math> 5<math>^{\circ}</math>C</li> <li>Test time : 10 <math>\pm</math> 1second (both side dipping)</li> <li>Test procedure : measures after 24 hours</li> </ul>
Vibration	<ol style="list-style-type: none"> <li>No mechanical damage</li> <li><math>\Delta R</math> should be within <math>\pm(1\%+0.05\Omega)</math></li> </ol>	50m $\Omega$ Maximum	<ul style="list-style-type: none"> <li>Standard : JIS C 5201-1 4.22</li> <li>Test amplitude : 1.5mm</li> <li>Test procedure : frequency 10Hz - 55Hz - 10Hz each 2 hours in x, y, z direction.</li> </ul>

## ● ENVIRONMENTAL CHARACTERISTIC

The Environmental characteristic test should satisfy the test method, procedure, and standard.  
If there is no special comment, Each test performs in standard state.  
(temperature 20 $^{\circ}$ C, humidity 65%RH, pressure 1023mbar)

item	Permissible deviation		Test method															
	Resistor	Jumper																
Temperature cycle	<ol style="list-style-type: none"> <li>No mechanical damage</li> <li><math>\Delta R</math> should be within <math>\pm(1\%+0.1\Omega)</math></li> </ol>	50m $\Omega$ Maximum	<ul style="list-style-type: none"> <li>Standard : JIS C 5201-1 4.19</li> <li>Test procedure : &lt;Table 11&gt;</li> <li>Measure : after 100 cycles of procedure</li> <li>Test board : &lt;Fig 11&gt;</li> </ul> <p>&lt;Table 11&gt;</p> <table border="1"> <thead> <tr> <th>item</th> <th>1</th> <th>2</th> <th>3</th> <th>4</th> </tr> </thead> <tbody> <tr> <td>temp(<math>^{\circ}</math>C)</td> <td>-55<math>\pm</math>2</td> <td>5~35</td> <td>125<math>\pm</math>2</td> <td>5~35</td> </tr> <tr> <td>time(min)</td> <td>30</td> <td>15</td> <td>30</td> <td>15</td> </tr> </tbody> </table>	item	1	2	3	4	temp( $^{\circ}$ C)	-55 $\pm$ 2	5~35	125 $\pm$ 2	5~35	time(min)	30	15	30	15
item	1	2	3	4														
temp( $^{\circ}$ C)	-55 $\pm$ 2	5~35	125 $\pm$ 2	5~35														
time(min)	30	15	30	15														
Moisture resistance life	<ol style="list-style-type: none"> <li>No mechanical damage</li> <li><math>\Delta R</math> should be within &lt;Table 12&gt;</li> </ol> <table border="1"> <thead> <tr> <th>Range(<math>\Omega</math>)</th> <th><math>\Delta R</math> MAX</th> </tr> </thead> <tbody> <tr> <td>0.1 <math>\leq</math> R &lt; 1</td> <td><math>\pm 5\%</math>(L-Type)</td> </tr> <tr> <td>1 <math>\leq</math> R &lt; 10</td> <td><math>\pm 5\%</math></td> </tr> <tr> <td>10 <math>\leq</math> R &lt; 1M</td> <td><math>\pm(3\%+0.1\Omega)</math></td> </tr> <tr> <td>1M <math>\leq</math> R &lt; 10M</td> <td><math>\pm 5\%</math></td> </tr> </tbody> </table>	Range( $\Omega$ )	$\Delta R$ MAX	0.1 $\leq$ R < 1	$\pm 5\%$ (L-Type)	1 $\leq$ R < 10	$\pm 5\%$	10 $\leq$ R < 1M	$\pm(3\%+0.1\Omega)$	1M $\leq$ R < 10M	$\pm 5\%$	100m $\Omega$ Maximum	<ul style="list-style-type: none"> <li>Standard : JIS C 5201-1 4.14</li> <li>Test condition : temp 40 <math>\pm</math> 3<math>^{\circ}</math>C, humid 90 ~ 95%RH</li> <li>Test voltage : rated voltage</li> <li>Test time : repeat 90min ON, 30min OFF during 1000<sup>48</sup> hours</li> <li>Test board : &lt;Fig 11&gt;</li> </ul>					
Range( $\Omega$ )	$\Delta R$ MAX																	
0.1 $\leq$ R < 1	$\pm 5\%$ (L-Type)																	
1 $\leq$ R < 10	$\pm 5\%$																	
10 $\leq$ R < 1M	$\pm(3\%+0.1\Omega)$																	
1M $\leq$ R < 10M	$\pm 5\%$																	



item	Permissible deviation		Test method
	Resistor	Jumper	
Low temperature exposure	1. No mechanical damage 2. $\Delta R$ should be within $\pm(3\%+0.1\Omega)$	50m $\Omega$ Maximum	<ul style="list-style-type: none"> <li>Standard : JIS C 5201-1 4.23</li> <li>Test temperature : <math>-55 \pm 2^\circ\text{C}</math></li> <li>Test time : 1000<sup>48</sup> hours (without load)</li> <li>Measure : after 1 hour</li> <li>Test board : &lt;Fig 11&gt;</li> </ul>
High temperature exposure	1. No mechanical damage 2. $\Delta R$ should be within $\pm(3\%+0.1\Omega)$	50m $\Omega$ Maximum	<ul style="list-style-type: none"> <li>Standard : JIS C 5201-1 4.23</li> <li>Test temperature : 1608,2012,3216 <math>155 \pm 2^\circ\text{C}</math>, Others <math>125 \pm 2^\circ\text{C}</math></li> <li>Test time : 1000<sup>48</sup> hours (without load)</li> <li>Measure : after 1 hour</li> <li>Test board : &lt;Fig 11&gt;</li> </ul>
Load life	1. No mechanical damage 2. $\Delta R$ should be within <Table 13>	100m $\Omega$ Maximum	<ul style="list-style-type: none"> <li>Standard : JIS C 5201-1 4.25</li> <li>Test temperature : <math>70 \pm 2^\circ\text{C}</math></li> <li>Test voltage : rated voltage</li> <li>Test time : repeat 90min ON, 30min OFF during 1000<sup>48</sup> hours</li> <li>Test board : &lt;Fig 11&gt;.</li> </ul>

## ● TEST BOARD AND SPECIFICATION

### ► Soldering (for lead free type)

▷ The resistor should be fixed on PCB(printed circuit board) for testing.

- Soldering specification : JIS C 5201-1 4.18

\* Soldering method : Flow type(Dipping type), Reflow type

\* Solder : Sn -3.0Ag -0.5Cu

\* FLUX : ROSIN 25WT% (JIS K 5902), IPA 75WT% (JIS K 5901)

- Flow soldering condition

\* FLUX dipping time : 5~10 sec

\* Pre-treatment : None

\* Soldering temp :  $260^\circ\text{C} \pm 5^\circ\text{C}$

\* Soldering time :  $10 \pm 1$  sec

► Test board

▷ Test board

<Table 14>

item		Dimension (mm)			
Dimension	Power	a	b	c	f
0603	1/20W	0.3	1.1	0.45	5.2
1005	1/16W	0.6	1.9	0.7	4.9
1608	1/10W	1.0	3.0	1.2	4.5
2012	1/8W	1.2	4.0	1.65	4.3
3216	1/4W	2.2	5.0	2.0	3.3
3225	1/3W	2.2	5.0	2.9	3.3
5025	2/3W	3.6	7.0	3.0	3.0
6432	1W	5.2	8.0	3.5	2.5

<Fig 11>

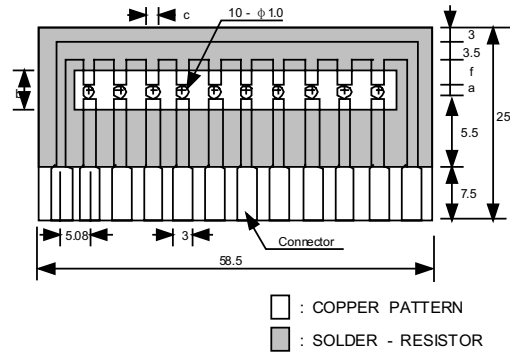

<Table 14>, <Fig 11> are dimensions of test board.

\* Board material : epoxy JIS C 6484

\* pattern material : pure copper 99.5% or above JIS C 6484

▷ Bending Test Board

<Table 15>

item		Dimension (mm)			
Dimension	Power	a	b	c	f
0603	1/20W	0.3	1.1	0.45	5.2
1005	1/16W	0.6	1.9	0.7	4.9
1608	1/10W	1.0	3.0	1.2	4.5
2012	1/8W	1.2	4.0	1.65	4.3
3216	1/4W	2.2	5.0	2.0	3.3
3225	1/3W	2.2	5.0	2.9	3.3
5025	2/3W	3.6	7.0	3.0	3.0
6432	1W	5.2	8.0	3.5	2.5

<Fig 12>

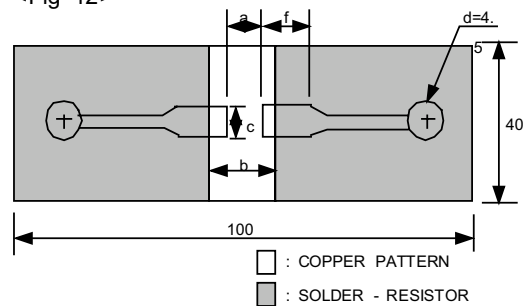

<Table 15>, <Fig 12> are dimensions of bending test board.

\* Board material : epoxy JIS C 6484

\* pattern material : pure copper 99.5% or above JIS C 6484

► Sketch of Withstanding voltage and Insulation resistance

<Fig 13>

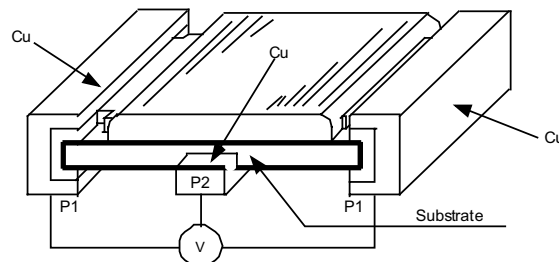

## PACKAGING

### ● PACKAGING METHOD

Packaging protects the resistor from damage during the shipping or storage.

There are two types of packaging method ; one is "Reel" type, and the other is "Bulk" type.

### ● REEL TYPE PACKAGING SPECIFICATION

The packaging specification is based on the EIAJ RC-1009.

<Fig 2> is tape dimension For 0603type. <Table 5> is for pocket sizes, A and B.

<Fig 2>

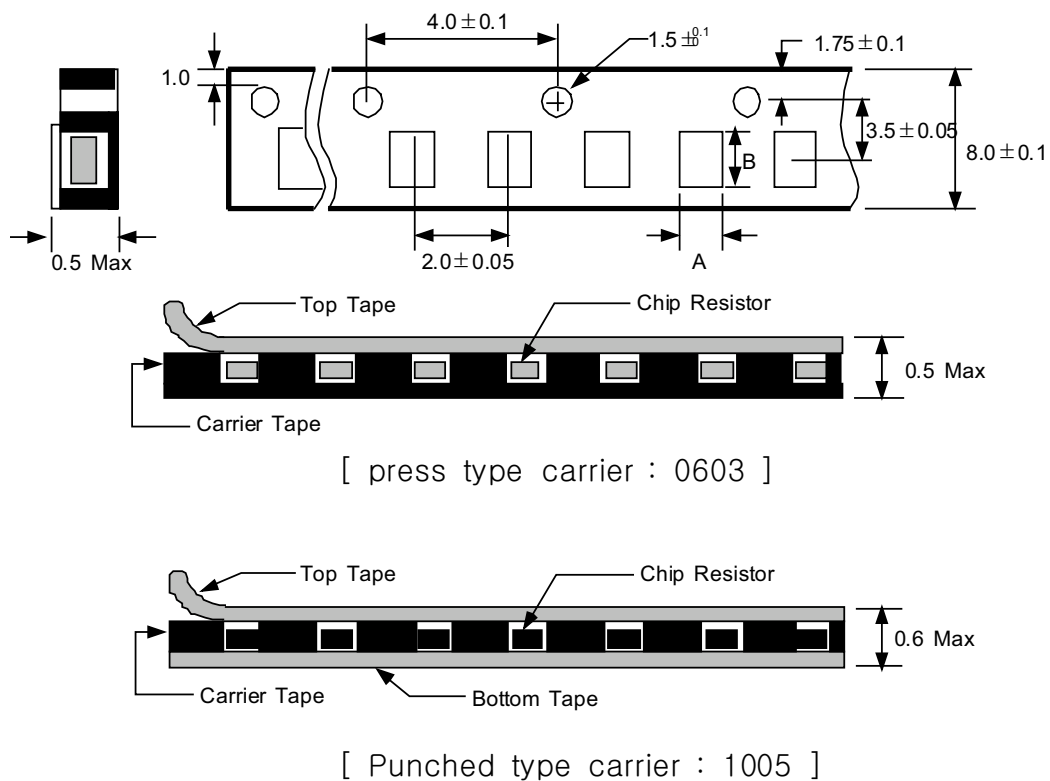

<Fig 3> is tape dimension For 1608, 2012, 3216, 3225 type. <Table 5> is for pocket sizes, A and B.

<Fig 3>

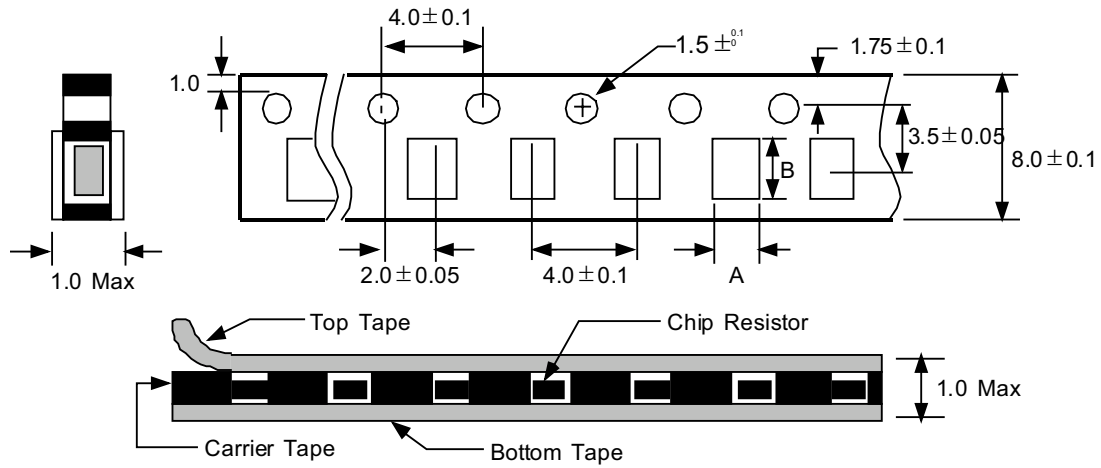

<Fig 4> is tape dimension For 5025, 6432 type. <Table 5> is for pocket sizes, A and B.

<Fig 4>

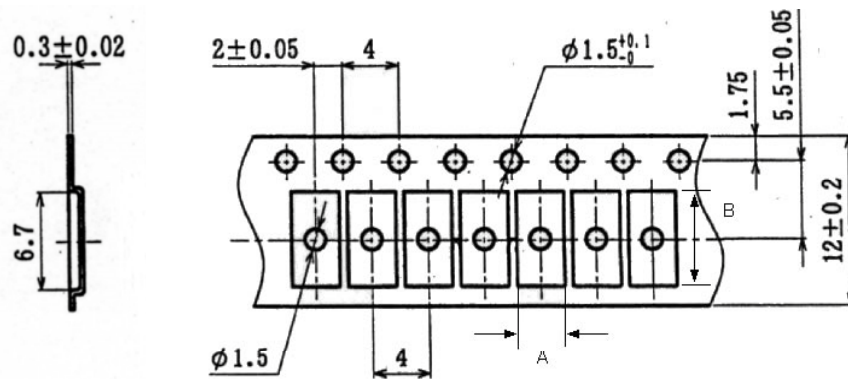

<Table 5>

Dimension	0603	1005	1608	2012	3216	3225	5025	6432
Symbol	(0201)	(0402)	(0603)	(0805)	(1206)	(1210)	(2010)	(2512)
A	0.38 ± 0.05	0.70 ± 0.10	1.10 ± 0.20	1.65 ± 0.20	2.00 ± 0.20	2.90 ± 0.20	2.80 ± 0.10	3.50 ± 0.10
B	0.68 ± 0.05	1.20 ± 0.10	1.90 ± 0.20	2.40 ± 0.20	3.60 ± 0.20	3.60 ± 0.20	5.30 ± 0.20	6.75 ± 0.10

## ● TAPING METHOD

There are empty pocket at both the start and end part of the carrier tape. <Fig 5>

<Fig 5>

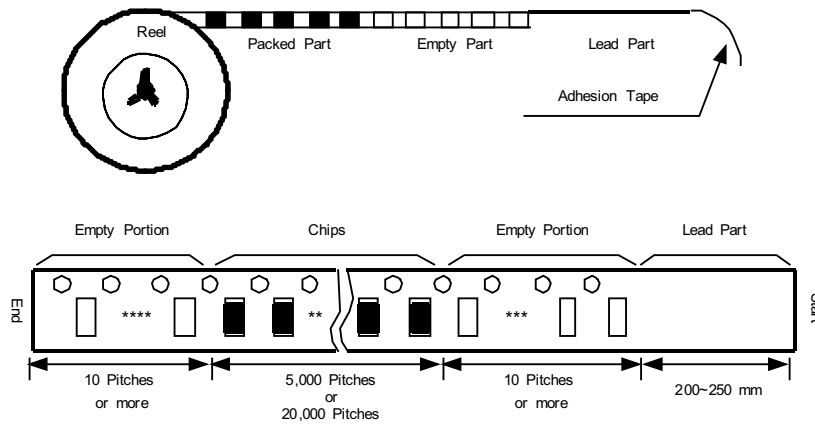

### Note

- ① The resistor should move in the pocket freely.
- ② The resistor should not adhere to the top or bottom tape.
- ③ There should be no vacant pocket.
- ④ Peeling strength of the top tape should be within 5g and 80g. <Fig 6>

<Fig 6>

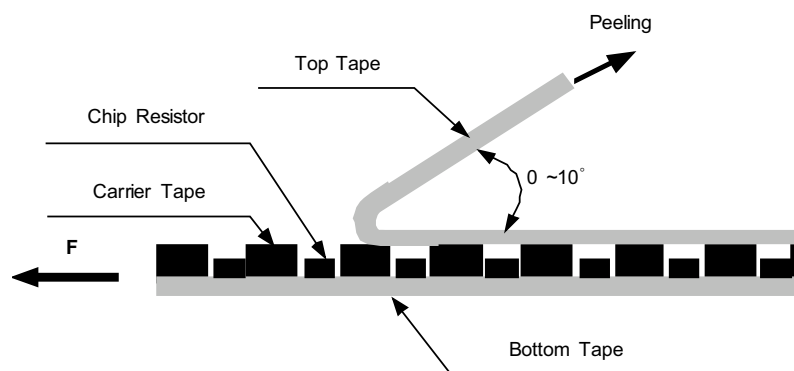

## ● REEL DIMENSION

The Reel dimension is classified by the diameter of Reel. <Fig 7> <Table 6>

<Fig 7>

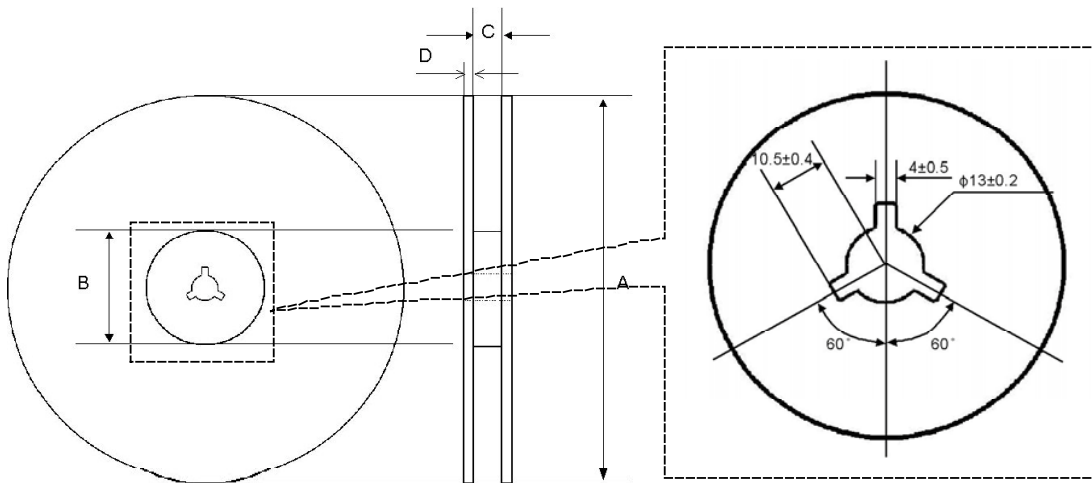

< Table 6 >

[ Unit : mm ]

Packaging Code	Diameter	A	B	C	D
C S	7"	178	Φ 70	9.5(13.0) ± 0.1	1.2 ± 0.1
E S	10"	258	Φ 80	9.5 ± 0.1	2.0 ± 0.1
F S, A S	13"	330	Φ 80	9.5(13.0) ± 0.1	2.0 ± 0.1

## ● BULK TYPE PACKAGING

Bulk cassette specification is based on the EIAJ ET-7201. <Fig 8>

The standard packaging quantity depends on the dimension. <Table 7>

<Fig 8>

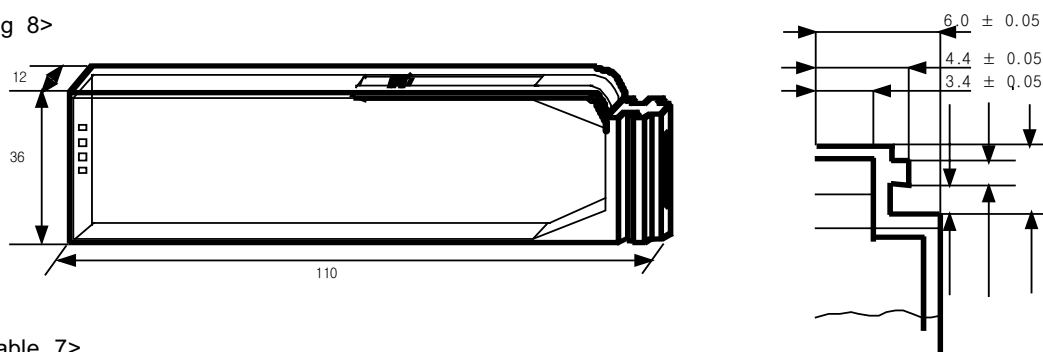

<Table 7>

Dimension	Inch	Standard packaging quantity	Weight (g, avg.)
1608	0603	25,000 PCS	71
2012	0805	10,000 PCS	65
3216	1206	5,000 PCS	67

## ● LABELING

### ▶ Reel type Label

The reel type label includes the following contents as <Fig 9>.

<Fig 9>

- ① Resistance Value
- ② Tolerance, Marking
- ③ Part Number
- ④ Quantity
- ⑤ LOT Number
- ⑥ Bar - Code
- ⑦ Serial Number
- ⑧ S : Pb Free  
P : Polymer & Pb Free

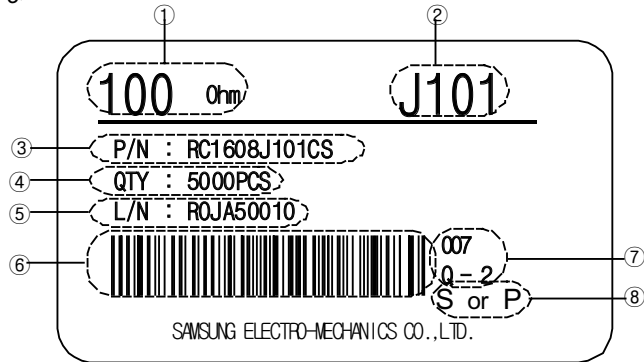

### ▶ Bulk type Label

The bulk type label includes following contents as <Fig 10>.

<Fig 10>

- ① Part Number
- ② Resistance Value
- ③ LOT Number
- ④ Quantity
- ⑤ Bar - Code
- ⑥ Serial Number

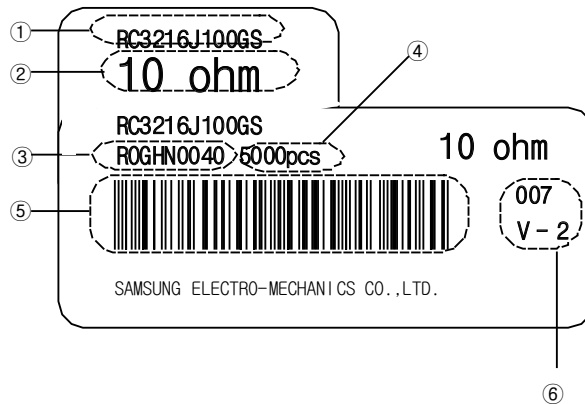

## ● BOX PACKAGING METHOD

- ① The bulk or reel type packaging is packaged twice by paper box, inner box and outer box.
- ② The packaging should protect the resistor from damage during shipping by land sea or air
- ③ The information of contents is indicated on both inner and outer box.

※ For other packaging methods, please contact us.

● BOX DIMENSION FOR REEL TYPE

① Max 75,000 pcs ( 5 EA × 7" )

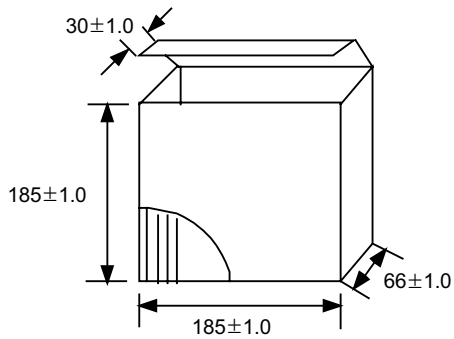

( Unit : mm )

② Max 300,000 pcs ( 20 EA × 7" )

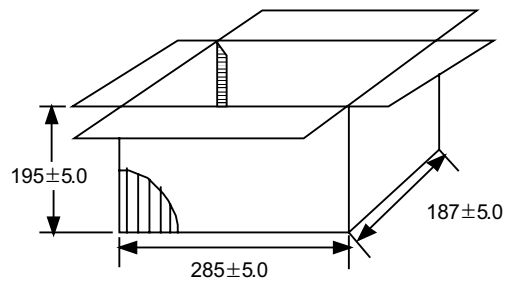

( Unit : mm )

③ Max 900,000 pcs ( 60 EA × 7" )

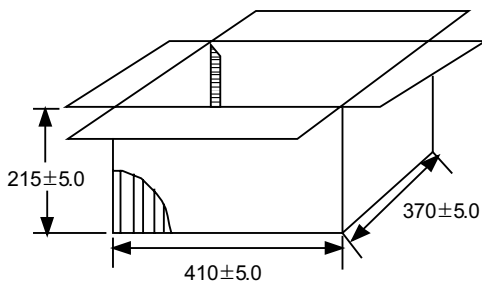

( Unit : mm )

④ Max 800,000 pcs ( 20 EA × 13" )

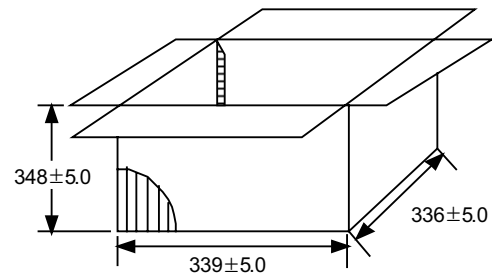

( Unit : mm )

● BOX DIMENSION FOR BULK TYPE

① Inner box ( Cassette × 5 EA )

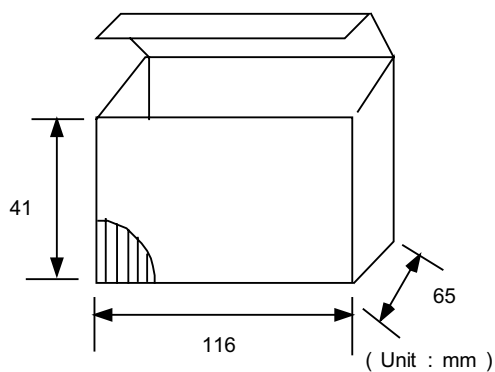

( Unit : mm )

② Outer box ( Inner box × 20 EA )

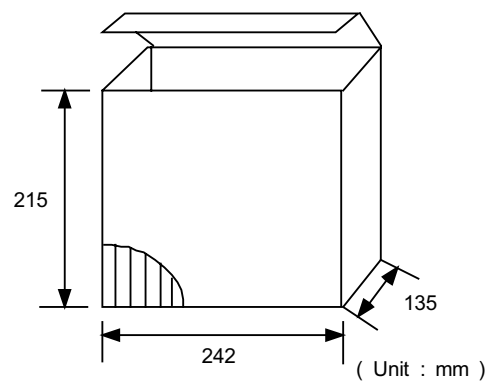

( Unit : mm )



## APPLICATION MANUAL

### ● APPLICATIONS

Chip resistors are designed for general electronic devices such as home appliances, computer, mobile communications, digital circuit, etc.

If you require our products with high reliability-performing at more than 125C or below -55C for medical equipments, aircraft, high speed machines, military usage, and items that can affect human life or if you need to use in specific conditions (corrosive gas atmosphere), please contact us beforehand.

▶ **Normal Operation temperature ranges(°C) as follows.**

- 1608, 2012, 3216(general, precision) : -55°C ~ + 155°C
- Others (rectangular, array, trimmable) : -55°C ~ + 125°C

- ▶ Although resistor body is coated, sharp excessive impact should be avoided to prevent damages and adverse effects on characteristics(resistor value, open circuited, T.C.R.).

### ● STORAGE

To maintain proper quality of chip components, the following precautions are required for storage environment, method and period.

▶ **Storage Environment**

- Chip components may be deformed, if the temperature of packaged components exceeds 40°C.
- Do not store where the soldering properties can be deteriorated by harmful gas such as sulphurous gas, chlorine gas, etc.
- Bulk packed chip components should be used as soon as the seal is opened, thus preventing the solderability from deteriorating.
- The remaining unused chips should be put in the original bag and sealed again or store in a desiccator containing a desiccating agent.

▶ **Storage Time Period**

- Stored chip components should be used within 6 months after receiving the components. If 6 months or more have elapsed, please check the solderability before actually using.

## ● MOUNTING

Proper nozzle height must be given attention so as not to give excessive pressure on the chip during mounting on the PCB.

(Excessive pressure may cause exterior damage, change in resistance, circuit open, etc.)

## ● SOLDERING

Our products have Ag electrodes protected by double layer.

### ▶ 1st Ni Coating

- This prevents Ag electrode from leaching and enhance the bonding with Sn

### ▶ 2nd Sn Coating

- This is made of Sn 100% with melting point 232 °C to prevent it from melting when solder cream melts, and to enhance the bonding.

- Commercial solder creams are made of Sn-3.0Ag-0.5Cu with melting point 217 °C.

## ● CLEANING

If rosin flux is used, cleaning usually is unnecessary. When strongly activated flux is used, chlorine in the flux may dissolve into some types of cleaning fluids, thereby affecting the chip capacitors.

This means that the cleaning fluid must be carefully selected, and should always be new.

## ● CAUTION FOR CHIP RESISTOR SEPERATION FROM PCB

Chip resistor installation on PCB is similar phenomenon as chocolate chip on top of cake.

PCB has enough flexibility on outer force but Chip resistor can be defected without any bending.

(By chip resistor use of Ceramic, solder, metal)

Therefore, when separate from Chip resistor on PCB, be ware of any crack of chip

## ● OTHERS

### ▶ Manual work

Manual soldering can pose a great risk of creating thermal cracks in chip capacitors.

The hot soldering iron tip comes into direct contact with the end terminations, an operator's carelessness may cause the tip of the soldering iron to come into direct contact with the ceramic body of the capacitor.

Therefore the soldering iron must be handled carefully, and close attention must be paid to the selection of the soldering iron tip and to temperature control of the tip.

### ▶ Do not use more than rated voltage.(check the contents on the file)

## NOTICE

### ● RECOMMENDED USAGE OF THE RESISTOR

#### ▶ Flow Soldering

After mounting the resistor to PCB with paste, dip the PCB into solder bath. <Fig 15>

<Fig 15>

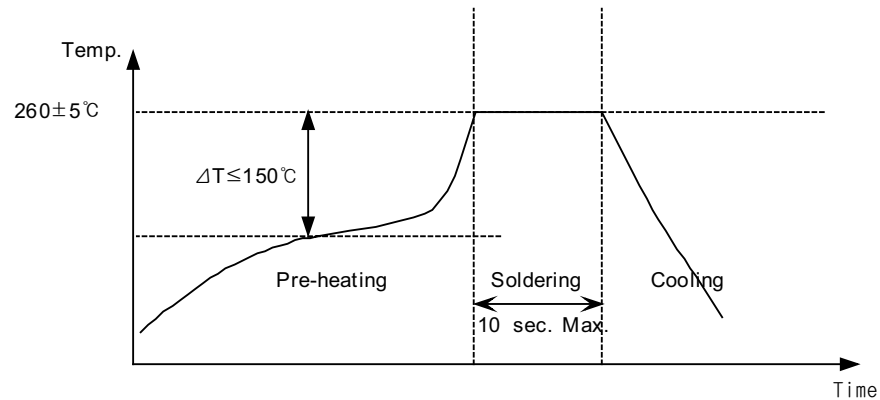

#### ▶ Reflow Soldering

After printing solder creams on PCB, place the resistor on the solder cream.

Then heat the PCB. <Fig 16>

<Fig 16>

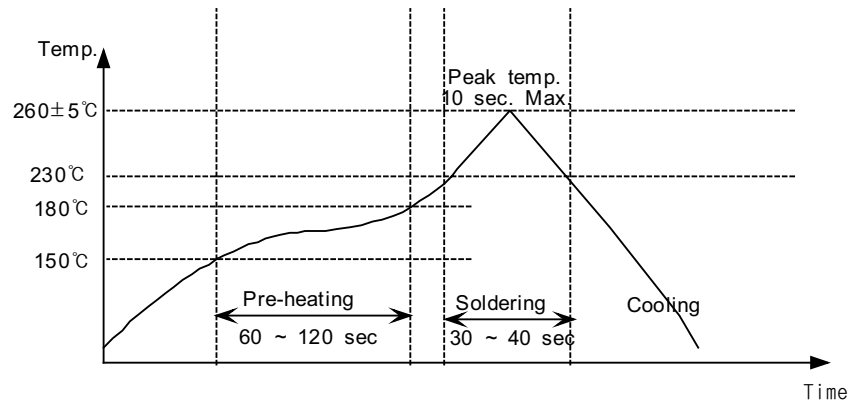

### ● CAUTION

#### ▶ Storage condition

Please make sure to keep the storage conditions.

\* Temperature : 5°C ~ 40°C, \* Humidity : 20%RH ~ 70%RH

#### ▶ Damage control

Please handle with care to prevent damaging the resistor.

Specially, the excessive nozzle height of SMD or the extreme pressure with tweezers.

#### ▶ Leaching prevention

It is important to keep the soldering conditions to prevent Ag leaching in Flow soldering.