

## Description

The 8V97003 is a high-performance mmWave wideband Synthesizer / Phase Lock Loop (PLL) that generates output frequencies up to 18GHz from an integrated Voltage Controlled Oscillator (VCO) offering an octave of frequency tuning range. The device also offers a high-performance 32-bit fractional feedback divider and an output divider to allow users to fully benefit from the wideband characteristics of the VCO.

The device's figure of merit (FOM) of -236dBc/Hz and the excellent VCO performance allow for very low phase noise and RMS phase jitter.

The 8V97003 offers a very low output-to-output phase skew drift of  $< 10^\circ$  across all operating conditions and frequencies, reducing radio path recalibration occurrences in beamforming applications, such as 5G radio card massive MIMO systems.

The output drivers have programmable output power settings and can deliver high single-ended output power up of +12dBm at 8GHz, and +4dBm at 18GHz, when using inductively loaded output terminations (double termination). When the outputs are resistively loaded, the output drivers can deliver a single-ended output power of +9.5dBm at 8GHz, and up to -2.5dBm at 12GHz. The output power can be further increased when using differential outputs and measuring the output power differentially.

The 8V97003 relies on a single 3.3V power supply and offers low noise integrated LDOs for excellent power supply noise immunity.

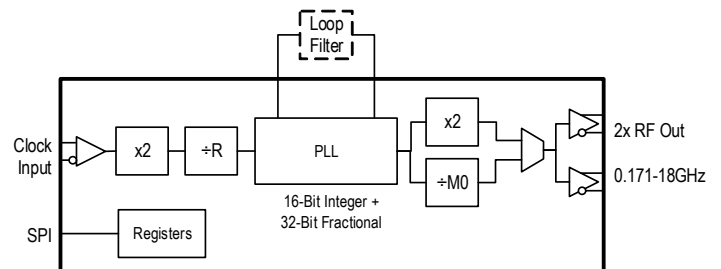
## Typical Applications

- 5G millimeter wave wireless infrastructure
- Massive MIMO
- Phase Array Antennas and beam forming
- Wireless backhaul
- Point-to-point and point-to-multipoint microwave links
- Satellites / VSATs
- Test equipment/instrumentation
- Clock generation
- High-speed RF converters sampling clocks
- Radar

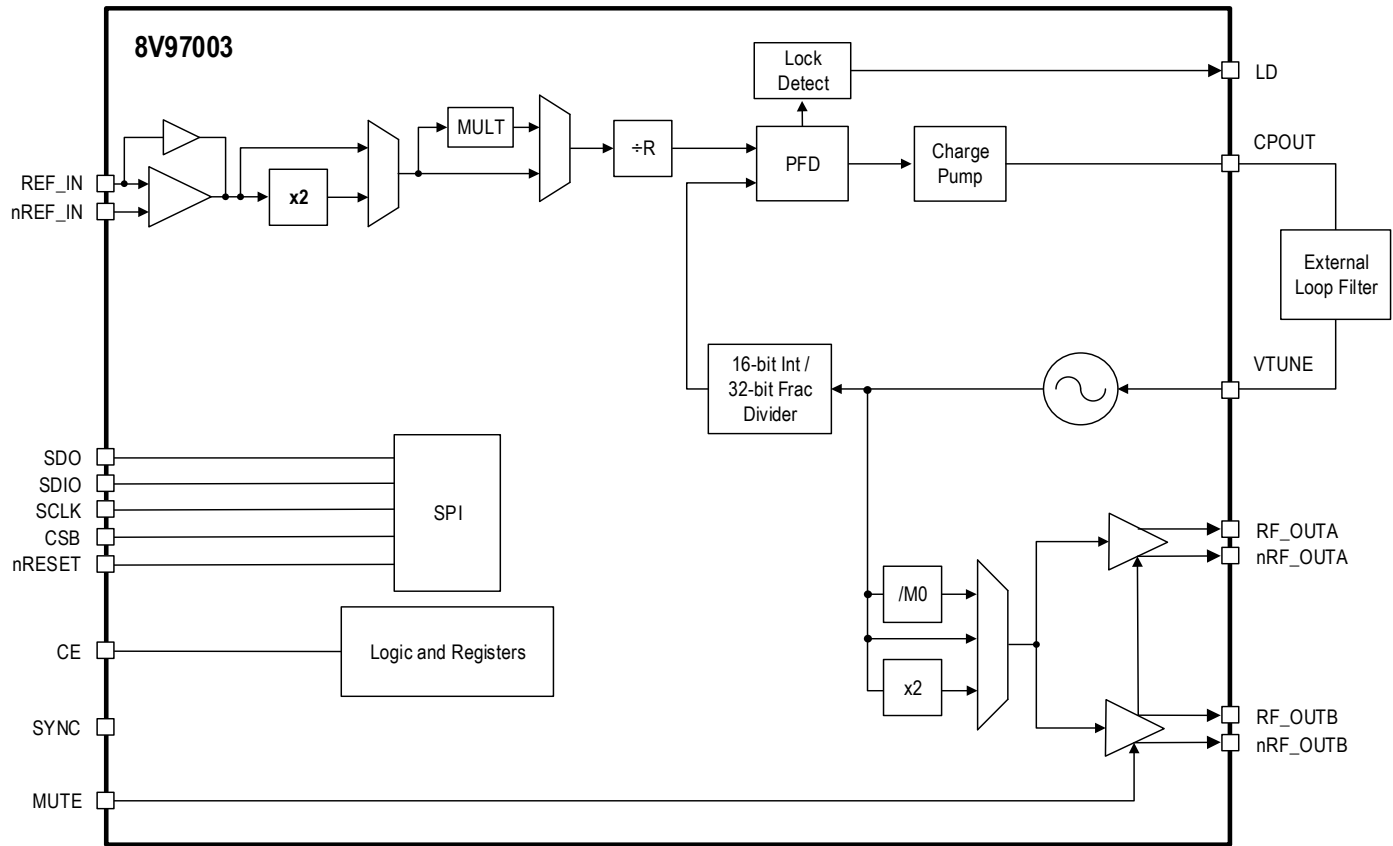
## Features

- Output frequency range: 171.875MHz to 18GHz
- Ultra-low phase noise VCO
  - -60.6dBc integrated phase jitter (35fs rms jitter) from 20kHz to 100MHz at 6GHz
- Figure of Merit: -236dBc/Hz
- Input reference frequency:
  - 10MHz to 1.6GHz (LVPECL, LVDS)
  - 10MHz to 250MHz (LVCMOS)
- Fractional-N synthesizer and integer-N synthesizer
- 32-bit of fractional and modulus resolution
- Phase frequency detector (PFD) operation up to 500MHz (Integer mode) or 250MHz (Fractional mode)
- Programmable RF output power levels
- RF output power  $< -80$ dBm when in MUTE
- Programmable input multiplier (MULT) to increase PFD frequency when using a low input frequency
- $-40^\circ\text{C}$  to  $+95^\circ\text{C}$  ambient temperature range; and up to  $+105^\circ\text{C}$  case temperature
- 3.3V single power supply operation
- $7 \times 7$  mm 48-VFQFPN package
- SPI interface is compatible with 1.8V logic and tolerant to 3.3V
- Supported in the Timing Commander™ design tool

## Simplified Block Diagram



# Block Diagram



## Contents

Description .....	1
Typical Applications.....	1
Features .....	1
Simplified Block Diagram .....	1
Block Diagram .....	2
Contents .....	3
Pin Assignments.....	8
Pin Descriptions .....	8
Absolute Maximum Ratings.....	11
Recommended Operating Conditions .....	11
Thermal Characteristics and Reliability Information .....	12
DC Electrical Characteristics .....	12
AC Electrical Characteristics .....	15
Typical Performance Characteristics.....	18
Theory of Operation .....	21
Synthesizer Programming.....	21
Reference Input Stage .....	22
Input Reference Divider (R) .....	22
Reference Doubler .....	22
Reference Multiplier (MULT).....	22
Feedback Divider .....	23
Phase and Frequency Detector (PFD) and Charge Pump.....	24
PFD Frequency .....	25
External Loop Filter .....	25
Charge Pump High-Impedance.....	25
Integrated Low Noise VCO .....	25
Output Clock Distribution and Optional Output Doubler.....	25
Output Matching.....	26
Band Selection Disable .....	27
Phase Adjust.....	27
RF Output Power .....	27
Output Phase Synchronization.....	27
Power-Down Mode.....	28
Default Power-Up Conditions.....	28
VCO Calibration .....	28
3- or 4-Wire SPI Interface Description.....	28
3/4-Wire Mode.....	28
Active Clock Edge .....	28
Reset.....	29
Least Significant Bit Position.....	29
Addressing .....	29
Read Operation.....	29
Mirrored Register Bits .....	29
Double-Buffered Registers.....	29
Operation Protocols .....	30
Register Map .....	34
Register Block Descriptions .....	37
Preface Registers.....	38

Feedback Divider Control Registers .....	40
Phase Adjustments Control Registers .....	42
DSM Control Registers .....	43
Calibration Control Registers .....	44
Band Select Clock Divider Control Registers.....	46
Lock Detect Control Registers .....	47
Power Down Control Registers .....	48
Input Control Registers .....	49
Charge Pump Control Registers .....	51
Re-Sync Control Registers.....	52
Output Control Registers.....	53
Status Registers.....	55
Applications Information .....	56
Loop Filter Calculations.....	56
2nd Order Loop Filter .....	56
3rd Order Loop Filter .....	58
Recommendations for Unused Input and Output Pins.....	59
Inputs.....	59
Outputs .....	59
Schematic Example .....	59
Power Considerations .....	61
Package Outline Drawings .....	61
Marking Diagram .....	62
Ordering Information .....	62
Revision History .....	63

## List of Figures

Figure 1. Pin Assignments for 7 × 7 mm 48-VFQFPN Package — Top View .....	8
Figure 2. Phase Noise at 6GHz (Fractional Mode).....	18
Figure 3. Phase Noise at 6GHz (Integer Mode) .....	18
Figure 4. Phase Noise at 8GHz (Integer Mode) .....	19
Figure 5. Phase Noise at 11GHz (Integer Mode) .....	19
Figure 6. Phase Noise at 18GHz (Integer Mode) .....	20
Figure 7. Phase Noise at 8GHz (Open Loop).....	20
Figure 8. Typical Output Power vs. RF Output Frequency (Over Different Loads).....	21
Figure 9. Input Reference Path.....	22
Figure 10. RF Feedback N Divider .....	23
Figure 11. Simplified PFD Circuit using D-type Flip-Flop.....	24
Figure 12. Output Clock Distribution .....	25
Figure 13. Output Stage .....	26
Figure 14. Resistive Matching Termination .....	26
Figure 15. Inductively Loaded Termination .....	27
Figure 16. 4-Wire MSB First, Single Byte Write and Read .....	30
Figure 17. 4-Wire LSB First, Single Byte Write and Read .....	31
Figure 18. 4-Wire MSB First, Multiple Bytes Write (2 Bytes Shown as Example) .....	31
Figure 19. 4-Wire LSB First, Multiple Bytes Read (2 Bytes Shown as Example) .....	32
Figure 20. 3-Wire MSB First, Single Byte Read and Write .....	32
Figure 21. SPI Timing Diagram .....	33
Figure 22. Typical 2 <sup>nd</sup> Order Loop Filter.....	56
Figure 23. Typical 3rd Order Loop Filter .....	58
Figure 24. Loop Filter Example.....	58
Figure 25. Schematic Example .....	60

## List of Tables

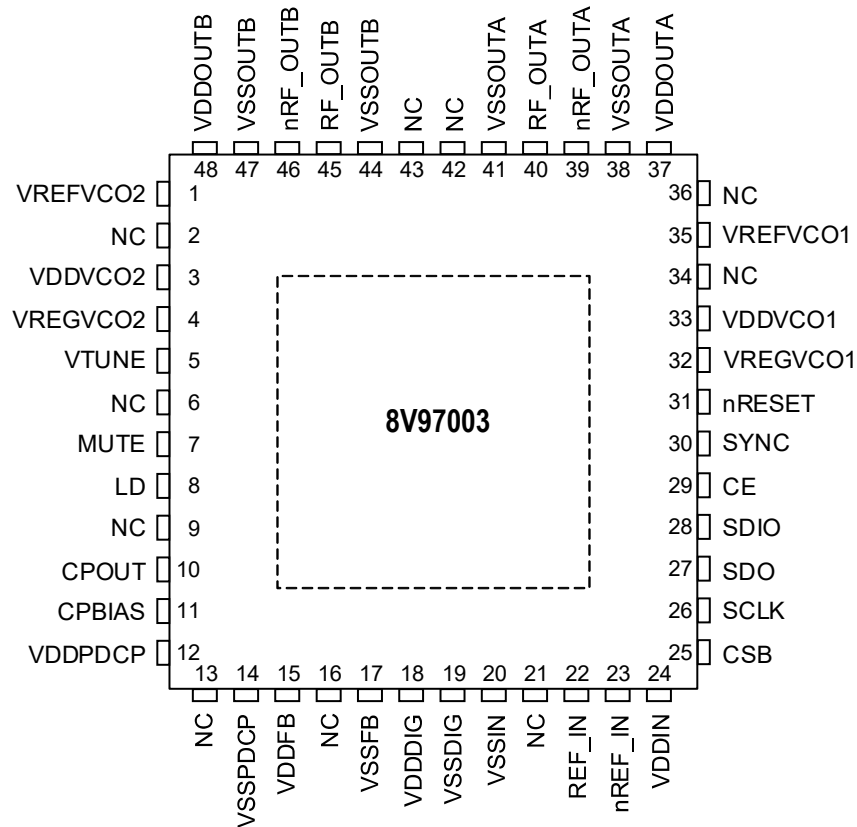
Table 1.	Pin Descriptions .....	8
Table 2.	Pin Characteristics .....	10
Table 3.	Supply Pins and Associated Current Return Paths.....	10
Table 4.	Absolute Maximum Ratings .....	11
Table 5.	Recommended Operating Conditions .....	11
Table 6.	Thermal Characteristics .....	12
Table 7.	Thermal Resistance $\theta_{JA}$ for 48-VFQFPN, Forced Convection.....	12
Table 8.	Power Supply DC Characteristics, $V_{DDx} = 3.3V \pm 5\%$ , $T_A = -40^\circ C$ to $+95^\circ C$ (Not Exceeding Max. Case or Junction Temp.) .....	12
Table 9.	Typical Current by Power Domain .....	13
Table 10.	LVC MOS DC Characteristics, $V_{DDx} = 3.3V \pm 5\%$ , $T_A = -40^\circ C$ to $+95^\circ C$ (Not Exceeding Max. Case or Junction Temp.) .....	14
Table 11.	AC Characteristics, $V_{DDx} = 3.3V \pm 5\%$ , $T_A = -40^\circ C$ to $+95^\circ C$ (Not Exceeding Maximum Case or Junction Temp.) .....	15
Table 12.	RF_OUT[A:B] Phase Noise Char., $V_{DDx} = 3.3V \pm 5\%$ , $T_A = -40^\circ C$ to $+95^\circ C$ (Not Exceeding Max. Case or Junction Temp.) .....	16
Table 13.	Fractional Spurs Due to the Quantization Noise .....	24
Table 14.	Timing Requirements .....	28
Table 15.	SPI Read / Write Cycle Timing Parameters .....	33
Table 16.	Preface Registers .....	34
Table 17.	Control Registers .....	34
Table 18.	Status Registers.....	36
Table 19.	Register Block Descriptions .....	37
Table 20.	Preface Register Block .....	38
Table 21.	Preface Register Bits .....	38
Table 22.	Preface Register Description .....	39
Table 23.	Feedback Divider Control Block.....	40
Table 24.	Feedback Divider Control Register Bits .....	40
Table 25.	Feedback Divider Control Register Description .....	41
Table 26.	Phase Adjustments Control Register Block .....	42
Table 27.	Phase Adjustments Control Register Bits .....	42
Table 28.	Phase Adjustments Control Register Descriptions .....	42
Table 29.	DSM Control Register Block .....	43
Table 30.	DSM Control Register Bits .....	43
Table 31.	DSM Control Register Descriptions .....	43
Table 32.	Calibration Control Register Block .....	44
Table 33.	Calibration Control Register Bits .....	44
Table 34.	Calibration Control Register Descriptions .....	44
Table 35.	Band Select Clock Divider Control Register Block.....	46
Table 36.	Band Select Clock Divider Control Register Bits.....	46
Table 37.	Band Select Clock Divider Control Register Descriptions.....	46
Table 38.	Lock Detect Control Register Block .....	47
Table 39.	Lock Detect Control Register Bits .....	47
Table 40.	Lock Detect Control Register Descriptions .....	47
Table 41.	Power Down Control Register Block .....	48
Table 42.	Power Down Control Register Bits.....	48
Table 43.	Power Down Control Register Descriptions .....	48
Table 44.	Input Control Register Block .....	49
Table 45.	Input Control Register Bits .....	49
Table 46.	Input Control Register Descriptions .....	49
Table 47.	Charge Pump Control Register Block.....	51
Table 48.	Charge Pump Control Register Bits.....	51

---

Table 49. Charge Pump Control Register Descriptions .....	51
Table 50. Re-Sync Control Register Block.....	52
Table 51. Re-sync Control Register Bits .....	52
Table 52. Re-sync Control Register Descriptions .....	52
Table 53. Output Control Register Block.....	53
Table 54. Output Control Register Bits .....	53
Table 55. Output Control Register Descriptions.....	53
Table 56. Status Register Block.....	55
Table 57. Status Register Bits .....	55
Table 58. Status Register Descriptions.....	55
Table 59. Ordering Information .....	62
Table 60. Pin 1 Orientation in Tape and Reel Packaging.....	62

## Pin Assignments

Figure 1. Pin Assignments for 7 × 7 mm 48-VFQFPN Package – Top View



## Pin Descriptions

Table 1. Pin Descriptions

Pin Number	Name	Type	Pull-up/ Pull-Down	Description
1	VREFVCO2	Analog		Reference node for VCO regulator. Connect 22μF capacitor from this pin to GND.
2	NC	Unused		Do not connect.
3	VDDVCO2	Power		VDD power supply for VCO.
4	VREGVCO2	Analog		Regulator for VCO. Connect 22μF capacitor from this pin to GND.
5	VTUNE	Analog		VCO Tuning Voltage.
6	NC	Unused		Do not connect.
7	MUTE	Input	PD	Outputs disable / High-Impedance. 1.8V LVCMOS logic levels (3.3V tolerant).
8	LD	Output		Lock Detector (CMOS).
9	NC	Unused		Do not connect.
10	CPOUT	Analog		Charge Pump Output.



**Table 1. Pin Descriptions (Cont.)**

Pin Number	Name	Type	Pull-up/ Pull-Down	Description
11	CPBIAS	Analog		Bias node for charge pump. Connect 22μF capacitor from this pin to GND.
12	VDDPDCP	Power		VDD power supply for phase detector and charge pump.
13	NC	Unused		Do not connect.
14	VSSPDCP	Ground		VSS power supply ground for phase detector and charge pump.
15	VDDFB	Power		VDD power supply for feedback divider.
16	NC	Unused		Do not connect.
17	VSSFB	Ground		VSS power supply ground for feedback divider.
18	VDDDIG	Power		VDD power supply for Digital, SPI and SDM.
19	VSSDIG	Ground		VSS power supply ground for Digital, SPI and SDM.
20	VSSIN	Ground		VSS power supply ground for reference input path.
21	NC	Unused		Do not connect.
22	REF_IN	Input	PD	Differential reference clock input+ (LVDS, LVPECL, CMOS).
23	nREF_IN	Input	PD/PU	Differential reference clock input- (LVDS, LVPECL).
24	VDDIN	Power		VDD power supply for reference input path.
25	CSB	Input	PD	SPI Chip Select Bar. 1.8V LVCMOS logic levels (3.3V tolerant).
26	SCLK	Input		SPI Clock Input. 1.8V LVCMOS logic levels (3.3V tolerant).
27	SDO	Output		SPI Data Output.
28	SDIO	Input/Output	PU	SPI Data Input/ Output. 1.8V LVCMOS logic levels (3.3V tolerant).
29	CE	Input	PU	Chip Enable. 1.8V LVCMOS logic levels (3.3V tolerant).
30	SYNC	Input	PD	SYNC pin can be used to implement a deterministic delay between the reference input rising edge and the output signal rising edge. If not used, this pin can either be tied to ground, or left floating since it has an internal pulldown. 3.3V LVCMOS input.
31	nRESET	Input	PD	Chip Reset. 1.8V LVCMOS logic levels (3.3V tolerant).
32	VREGVCO1	Analog		Regulator for VCO. Connect 22μF capacitor from this pin to GND.
33	VDDVCO1	Power		VDD power supply for VCO.
34	NC	Unused		Do not connect.
35	VREFVCO1	Analog		Reference node for VCO regulator. Connect 22μF capacitor from this pin to GND.
36	NC	Unused		Do not connect.
37	VDDOUTA	Power		VDD output power supply for output pair A.
38	VSSOUTA	Ground		VSS power supply ground for output pair A.
39	nRF_OUTA	Output		Negative side of output pair A (CML – Open Collector). The output power level is programmable.
40	RF_OUTA	Output		Positive side of output pair A (CML – Open Collector). The output power level is programmable.

**Table 1. Pin Descriptions (Cont.)**

Pin Number	Name	Type	Pull-up/ Pull-Down	Description
41	VSSOUTA	Ground		VSS power supply ground for output pair A.
42	NC	Analog		Do not connect.
43	NC	Analog		Do not connect.
44	VSSOUTB	Ground		VSS power supply ground for output pair B.
45	RF_OUTB	Output		Positive side of output pair B (CML – open collector). The output power level is programmable.
46	nRF_OUTB	Output		Negative side of output pair B (CML – open collector). The output power level is programmable.
47	VSSOUTB	Ground		VSS power supply ground for output pair B.
48	VDDOUTB	Power		VDD output power supply output pair B.
EP	EPAD	Ground		Must be connected to ground.

**Table 2. Pin Characteristics**

Symbol	Parameter	Test Condition	Minimum	Typical	Maximum	Units
$C_{IN}$	Input Capacitance	REF_IN, nREF_IN		1		pF
$R_{OUT}$	LVC MOS Output Impedance	LD		15		$\Omega$
$R_{PULLUP}$	Input Pullup Resistor			50		k $\Omega$
$R_{PULLDOWN}$	Input Pulldown Resistor			50		k $\Omega$

**Table 3. Supply Pins and Associated Current Return Paths**

Power Supply		Associated Ground	
Pin Number	Pin Name	Pin Number	Pin Name
3	VDDVCO2	EP	EPAD
12	VDDPDCP	14	VSSPDCP
15	VDDFB	17	VSSFB
18	VDDDIG	19	VSSDIG
24	VDDIN	20	VSSIN
33	VDDVCO1	EP	EPAD
37	VDDOUTA	38; 41	VSSOUTA
48	VDDOUTB	44; 47	VSSOUTB

## Absolute Maximum Ratings

The absolute maximum ratings are stress ratings only. Stresses greater than those listed below can cause permanent damage to the device. Functional operation of the 8V97003 at absolute maximum ratings is not implied. Exposure to absolute maximum rating conditions may affect device reliability.

**Table 4. Absolute Maximum Ratings<sup>[a]</sup>**

Symbol	Parameter	Rating	Units
VDDx <sup>[b]</sup>	Supply Voltage	3.63	V
V <sub>I</sub>	Input Voltage (REF_IN, nREF_IN, MUTE, SDIO, VTUNE, SCLK, CSB, CE, nRESET, and SYNC)	-0.5 to VDDx <sup>[a]</sup> +0.5	V
V <sub>o</sub>	Output Voltage (RF_OUTA, nRF_OUTA, RF_OUTB, nRF_OUTB, LD, CPOUT, SDIO, SDO)	-0.5 to VDDx <sup>[a]</sup> +0.5	V
I <sub>o</sub>	Output Current	Continuous Current	60 mA
		Surge Current	90 mA
I <sub>o</sub>	Output Current (SDO, SDIO, LD)	Continuous Current	40 mA
		Surge Current	65 mA
T <sub>J</sub>	Maximum Junction Temperature	150	°C
T <sub>S</sub>	Storage Temperature	-65 to 150	°C
—	ESD – Human Body Model	2000	V
—	ESD – Charged Device Model	750	V

[a] Over operating ambient temperature range (unless otherwise indicated).

[b] VDDx denotes, VDDVCO2, VDDPDCP, VDDFB, VDDDIG, VDDIN, VDDVCO1, VDDOUTA, VDDOUTB.

## Recommended Operating Conditions

**Table 5. Recommended Operating Conditions<sup>[a][b]</sup>**

Symbol	Parameter	Minimum	Typical	Maximum	Units
T <sub>A</sub>	Ambient Air Temperature	-40		+95	°C
T <sub>C</sub>	Case Temperature <sup>[c]</sup>			+105	°C
T <sub>J</sub>	Junction Temperature			+125	°C

[a] It is the user's responsibility to ensure that device junction temperature remains below the maximum allowed.

[b] All conditions in this table must be met to guarantee device functionality.

[c] Measured at solder connection to printed circuit board on ePAD.

## Thermal Characteristics and Reliability Information

**Table 6. Thermal Characteristics**

Symbol	Parameter	Value	Units
$\theta_{JB}$	Theta JB. Junction to board	0.76	°C/W
$\theta_{JC}$	Theta JC. Junction to case	10.33	°C/W

**Table 7. Thermal Resistance  $\theta_{JA}$  for 48-VFQFPN, Forced Convection**

$\theta_{JA}$ by Velocity				
Air Flow	0	1	2	m/s
Multi-Layer PCB, JEDEC Standard Test Boards	22.3	18.84	17.3	°C/W

## DC Electrical Characteristics

**Table 8. Power Supply DC Characteristics, VDDx = 3.3V ±5%, T<sub>A</sub> = -40°C to +95°C (Not Exceeding Max. Case or Junction Temp.)<sup>[a][b][c]</sup>**

Symbol	Parameter	Conditions	Minimum	Typical	Maximum	Units
VDDx <sup>[d]</sup>	Power Supply Voltage		3.135	3.3	3.465	V
IDDx <sup>[e]</sup>	Power Supply Current <sup>[f]</sup>	RF_OUTA, nRF_OUTA – Active RF_OUTB, nRF_OUTB – Muted		516	590	mA
		RF_OUTA, nRF_OUTA – Active RF_OUTB, nRF_OUTB – Active		566	650	mA
		RF_OUTA, nRF_OUTA – Muted RF_OUTB, nRF_OUTB – Muted		464	538	mA
I <sub>VCO</sub>	VCO Supply Current	VCO Frequency = 6GHz		225	271	mA
—	Power Down Current	VCO Frequency = 6GHz		250	302	mA

[a] RF outputs terminated to 50Ω to VDDOUT[A:B].

[b] Output power set to 0101 (see RF\_OUTx\_pwr[3:0] in [Table 55](#)).

[c] Over [Recommended Operating Conditions](#) (unless otherwise indicated).

[d] VDDx denotes, VDDVCO2, VDDPDCP, VDDFB, VDDDIG, VDDIN, VDDVCO1, VDDOUTA, VDDOUTB.

[e] IDDx denotes IDDVCO2, IDDPDCP, IDDFB, IDDDIG, IDDIN, IDDVCO1, IDDOUTA, IDDOUTB.

[f] Input Frequency = 122.88MHz, Input Doubler Enabled, Output Frequency = 6GHz; PLL is in Fractional mode.

**Table 9. Typical Current by Power Domain<sup>[a][b]</sup>**

Pin Name	Pin Number	Condition	Typical	Unit
VDDVCO2, VDDVCO2 <sup>[c]</sup>	3, 33	8GHz VCO frequency	270	mA
VDDPDCP	12	I <sub>CP</sub> = 8mA	65	mA
VDDFB	15		49	mA
VDDDIG	18	PFD frequency: 245.76MHz DSM setting: 3rd Order (Fractional mode)	34	mA
		PFD frequency: 245.76MHz DSM OFF (Integer Mode)	23	mA
VDDIN	24	Input doubler OFF, MULT OFF, Input divider OFF	36	mA
VDDOUTA	37	RF_OUT Disabled	10	mA
		RF_OUTA Enabled; RF Output Power Setting: 0001 (Minimum setting)	43	mA
		RF_OUTA Enabled; RF Output Power Setting: 1100 (Maximum setting)	82	mA
VDDOUTB	48	RF_OUTB Disabled	54	mA
		RF_OUTB Enabled; RF Output Power Setting: 0001 (Minimum setting)	88	mA
		RF_OUTB Enabled; RF Output Power Setting: 1100 (Maximum setting)	126	mA
		RF_OUTB Enabled; RF Output Power Setting: 1100; Output doubler ON	137	mA
		RF_OUTB Enabled; RF Output Power Setting: 0010; Output Divider: Divide by 2	89	mA

[a] Operating conditions are: REF\_IN = 122.88MHz; RF\_OUTA = RF\_OUTB = 8GHz.

[b] Over [Recommended Operating Conditions](#) (unless otherwise indicated).

[c] Total current from VDDVCO1 and VDDVCO2 (externally connected).

**Table 10. LVC MOS DC Characteristics,  $V_{DDx}^{[a]} = 3.3V \pm 5\%$ ,  $T_A = -40^\circ C$  to  $+95^\circ C$  (Not Exceeding Max. Case or Junction Temp.)<sup>[b]</sup>**

Symbol	Parameter		Test Conditions	Minimum	Typical	Maximum	Units
$V_{IH}$	Input High Voltage	nRESET, CE, MUTE, CSB, SCLK, SDIO		1.2		$V_{DDx}^{[a]}$	V
		SYNC		2		$V_{DDx}^{[a]}$	V
$V_{IL}$	Input Low Voltage	nRESET, CE, MUTE, CSB, SCLK, SDIO				0.65	V
		SYNC				0.8	
$I_{IH}$	Input High Current	nRESET, CE, SDIO	$V_{DDx} = V_{IN} = 3.465V$			5	$\mu A$
		CSB, MUTE, SYNC	$V_{DDx} = V_{IN} = 3.465V$			150	$\mu A$
$I_{IL}$	Input Low Current	nRESET, CE, SDIO	$V_{DDx} = 3.465V, V_{IN} = 0V$	-150			$\mu A$
		CSB, MUTE, SYNC	$V_{DDx} = 3.465V, V_{IN} = 0V$	-5			$\mu A$
$V_{OH}$	Output High Voltage	SDO, SDIO <sup>[c]</sup> , LD	$V_{DDx} = 3.465V, I_{OH} = -2mA$	2.4			V
$V_{OL}$	Output Low Voltage	SDO, SDIO <sup>[c]</sup> , LD	$V_{DDx} = 3.465V, I_{OL} = 2mA$			0.4	V

[a]  $V_{DDx}$  denotes,  $V_{DDVCO2}$ ,  $V_{DDPDCP}$ ,  $V_{DDFB}$ ,  $V_{DDDIG}$ ,  $V_{DDIN}$ ,  $V_{DDVCO1}$ ,  $V_{DDOUTA}$ ,  $V_{DDOUTB}$ .

[b] Over [Recommended Operating Conditions](#) (unless otherwise indicated).

[c] SDIO as output.

## AC Electrical Characteristics

**Table 11. AC Characteristics, VDDx<sup>[a]</sup> = 3.3V ±5%, T<sub>A</sub> = -40°C to +95°C (Not Exceeding Maximum Case or Junction Temp.)<sup>[b]</sup>**

Symbol	Parameter	Test Conditions	Minimum	Typical	Maximum	Units	
REF_IN	Input Reference Frequency	Reference doubler disabled	10		1600	MHz	
		Reference doubler enabled	10		250	MHz	
V <sub>PP</sub>	REF_IN Input Sensitivity	Biased at VDDx/2 <sup>[c]</sup>	0.4		VDDx <sup>[a]</sup>	V	
f <sub>VCO</sub>	VCO Frequency	Fundamental VCO mode	5,500		11,000	MHz	
f <sub>RF_OUT</sub>	Output Frequency	Output doubler disabled	171.875		11,000	MHz	
		Output doubler enabled	11,000		18,000	MHz	
f <sub>PFD</sub>	PFD Frequency	Fractional mode			250	MHz	
		Integer mode			500	MHz	
K <sub>VCO</sub>	VCO Sensitivity <sup>[d]</sup>	VCO Frequency = 5.625GHz		100		MHz/V	
		VCO Frequency = 6.23GHz		120			
		VCO Frequency = 6.975GHz		140			
		VCO Frequency = 7.8GHz		160			
		VCO Frequency = 8.65GHz		210			
		VCO Frequency = 9.575GHz		165			
		VCO Frequency = 10.3GHz		155			
		VCO Frequency = 10.9GHz		170			
t <sub>LOCK</sub>	PLL Lock Time <sup>[e]</sup>	Time from Low to High of CSB until Low to High of LD		1		ms	
	Frequency Lock Time	One frequency to another frequency locking time when VCO calibration is bypassed.		70		µs	
-	Single-Ended RF Output Power <sup>[f]</sup>	Muted		< -80		dBm	
		RF_OUTn_pwr = 1100 (max) 50-ohm Resistive Loading	RF_OUT = 8GHz		9.5		dBm
			RF_OUT = 18GHz		-2.5		dBm
		RF_OUTn_pwr = 0110 50-ohm Resistive Loading	RF_OUT = 8GHz		5		dBm
			RF_OUT = 18GHz		-6.5		dBm
		RF_OUTn_pwr = 1100 (max) 1nH Inductive Loading	RF_OUT = 8GHz		12		dBm
		RF_OUTn_pwr = 1100 (max) 0.6nH Inductive Loading	RF_OUT = 18GHz		4		dBm
-	RF Output Power Variation Across Temperature <sup>[g]</sup>	RF_OUT at 11GHz		±2		dBm	
		RF_OUT from 11GHz to 18GHz		±4		dBm	
-	Min/Max VCO Tuning Voltage			0.3/2.2		V	

**Table 11. AC Characteristics, VDDx<sup>[a]</sup> = 3.3V ±5%, T<sub>A</sub> = -40°C to +95°C (Not Exceeding Maximum Case or Junction Temp.)<sup>[b]</sup> (Cont.)**

Symbol	Parameter	Test Conditions	Minimum	Typical	Maximum	Units
-	Output-to-Output Skew				5	ps
-	Output-to-Output Skew Drift	Any value of f <sub>RF_OUT</sub> . Measurement taken from -40°C to +95°C.		2	10	°
-	Input-to-Output Skew Drift	Any value of f <sub>RF_OUT</sub> . Measurement taken from -40°C to +95°C.		9		ps

[a] VDDx denotes VDDVCO2, VDDPDCP, VDDFB, VDDDIG, VDDIN, VDDVCO1, VDDOUTA, VDDOUTB.

[b] Over [Recommended Operating Conditions](#) (unless otherwise indicated).

[c] AC-coupling the reference signal ensures VDDx / 2 biasing.

[d] The value depends on VCO frequency.

[e] Band Select/Calibration Resolution = 4x (BandSelAcc[1:0]=10), FPF/D/BndSelDiv ~100kHz

[f] Single-Ended RF Output Power values are based on after de-embedding the trace and cable losses while other output is connected with same length of cable and terminated to 50 ohm resistor. For output terminations, see [Figure 25](#).

[g] Output Power setting = 0110b.

**Table 12. RF\_OUT[A:B] Phase Noise Char., VDDx<sup>[a]</sup> = 3.3V ±5%, T<sub>A</sub> = -40°C to +95°C (Not Exceeding Max. Case or Junction Temp.)<sup>[b]</sup>**

Symbol	Parameter	Test Conditions	Minimum	Typical	Maximum	Units
tjit(∅)	Integrated Phase Noise/Jitter	f <sub>RF_OUT</sub> = 6GHz Integration Range: 20kHz – 100MHz PFD = 245.76MHz (Fractional Mode)		-55	-48.8	dBc
				66		fs
		f <sub>RF_OUT</sub> = 6GHz Integration Range: 20kHz – 100MHz PFD = 500MHz (Integer Mode)		-60.6	-57.4	dBc
				35	50	fs
		f <sub>RF_OUT</sub> = 8GHz Integration Range: 20kHz – 100MHz PFD = 500MHz (Integer Mode)		-57.6	-55	dBc
				36.8	50	fs
Φ <sub>N</sub> (10k)	RF Output Phase Noise Performance at 6GHz (Open Loop)	f <sub>RF_OUT</sub> = 11GHz Integration Range: 20 kHz – 100MHz PFD = 500MHz (Integer Mode)		-53.3	-40.2	dBc
				44		fs
		f <sub>RF_OUT</sub> = 18GHz Integration Range: 20 kHz – 100MHz PFD = 250kHz (Integer Mode)		-50.2	-46.4	dBc
				38.5	58	fs
		10kHz offset from carrier		-74.9	-72.8	dBc/Hz
Φ <sub>N</sub> (100k)		100kHz offset from carrier		-104.8	-102.7	dBc/Hz
Φ <sub>N</sub> (1M)		1MHz offset from carrier		-133.2	-130.9	dBc/Hz
Φ <sub>N</sub> (10M)		10MHz offset from carrier		-153.8	-152.6	dBc/Hz
Φ <sub>N</sub> (60M)		60MHz offset from carrier		-157.8	-156.8	dBc/Hz



**Table 12. RF\_OUT[A:B] Phase Noise Char., VDDx<sup>[a]</sup> = 3.3V ±5%, T<sub>A</sub> = -40°C to +95°C (Not Exceeding Max. Case or Junction Temp.)<sup>[b]</sup> (Cont.)**

Symbol	Parameter	Test Conditions	Minimum	Typical	Maximum	Units
$\Phi_N(10k)$	RF Output Phase Noise Performance at 8GHz (Open Loop)	10kHz offset from carrier		-71.5	-69.3	dBc/Hz
$\Phi_N(100k)$		100kHz offset from carrier		-101.9	-100.6	dBc/Hz
$\Phi_N(1M)$		1MHz offset from carrier		-130.6	-128.4	dBc/Hz
$\Phi_N(10M)$		10MHz offset from carrier		-152.1	-149.5	dBc/Hz
$\Phi_N(60M)$		60MHz offset from carrier		-157.7	-155.7	dBc/Hz
$\Phi_N(10k)$	RF Output Phase Noise Performance at 11GHz (Open Loop)	10kHz offset from carrier		-67.1	-65.2	dBc/Hz
$\Phi_N(100k)$		100kHz offset from carrier		-98	-93.3	dBc/Hz
$\Phi_N(1M)$		1MHz offset from carrier		-125.1	-114.2	dBc/Hz
$\Phi_N(10M)$		10MHz offset from carrier		-144.7	-133.2	dBc/Hz
$\Phi_N(60M)$		60MHz offset from carrier		-150.8	-142.2	dBc/Hz
$\Phi_N(10k)$	RF Output Phase Noise Performance at 18GHz (Open Loop)	10kHz offset from carrier		-64.6	-62.7	dBc/Hz
$\Phi_N(100k)$		100kHz offset from carrier		-95.5	-93.2	dBc/Hz
$\Phi_N(1M)$		1MHz offset from carrier		-123.4	-119.9	dBc/Hz
$\Phi_N(10M)$		10MHz offset from carrier		-144.1	-140.0	dBc/Hz
$\Phi_N(60M)$		60MHz offset from carrier		-148.6	-142.1	dBc/Hz
—	Spurious Signals due to PFD Frequency	f <sub>PFD</sub> = 245.76MHz; RF_OUT = 7.86432GHz; Integer Mode		-83.2	-77.5	dB
		f <sub>PFD</sub> = 245.76MHz; RF_OUT = 8GHz; Fractional Mode		-74.1	-69.9	dB
$\Phi_N(\text{SYNTH})$	Normalized Phase Noise Floor			-236		dBc/Hz
$\Phi_N(1/f)$	Normalized 1/f Noise <sup>[c]</sup>	10kHz Offset; f <sub>RF_OUT</sub> = 8GHz		-132		dBc/Hz
H2	VCO second harmonic	f <sub>VCO</sub> = 8GHz		-36		dB
H3	VCO third harmonic	f <sub>VCO</sub> = 8GHz		-33		

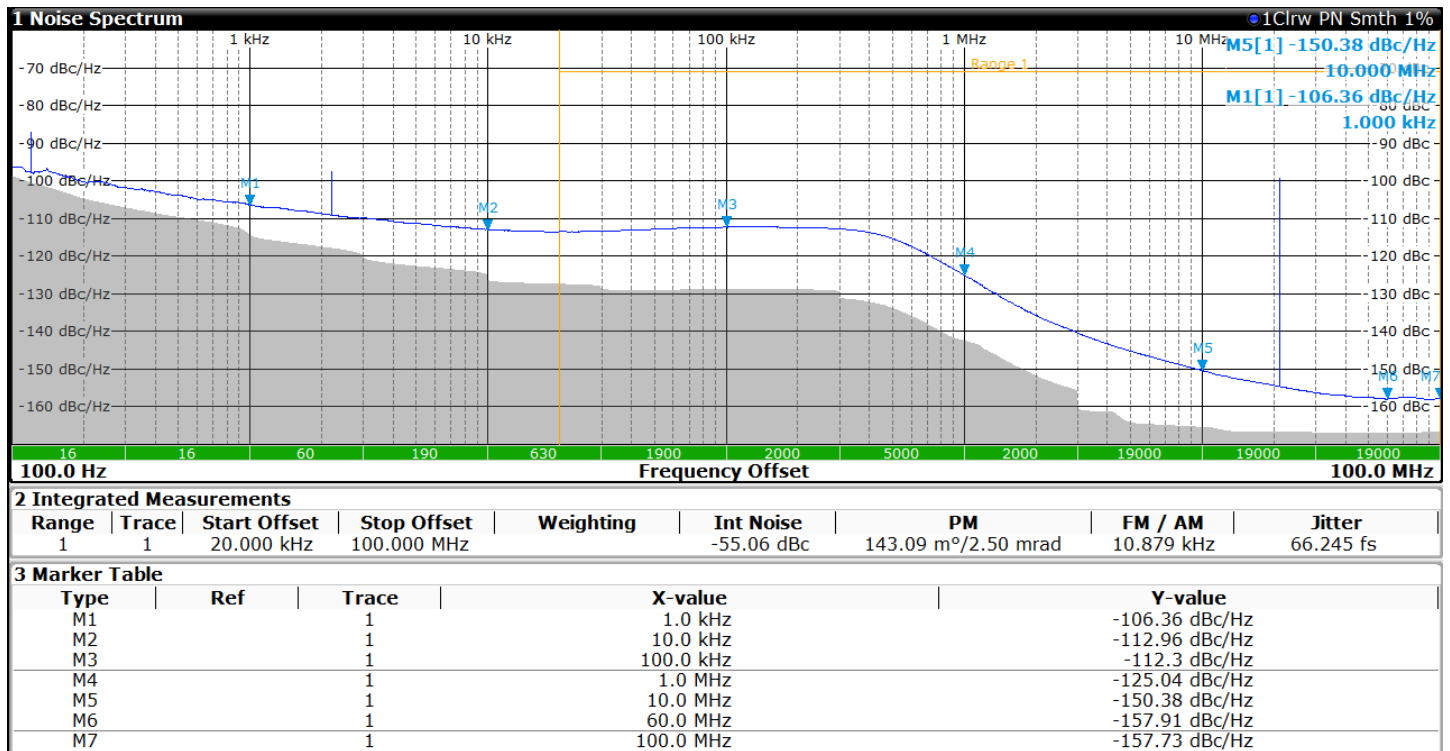
[a] VDDx denotes VDDVCO2, VDDPDCP, VDDFB, VDDDIG, VDDIN, VDDVCO1, VDDOUTA, VDDOUTB.

[b] Over recommended operating conditions (unless otherwise indicated).

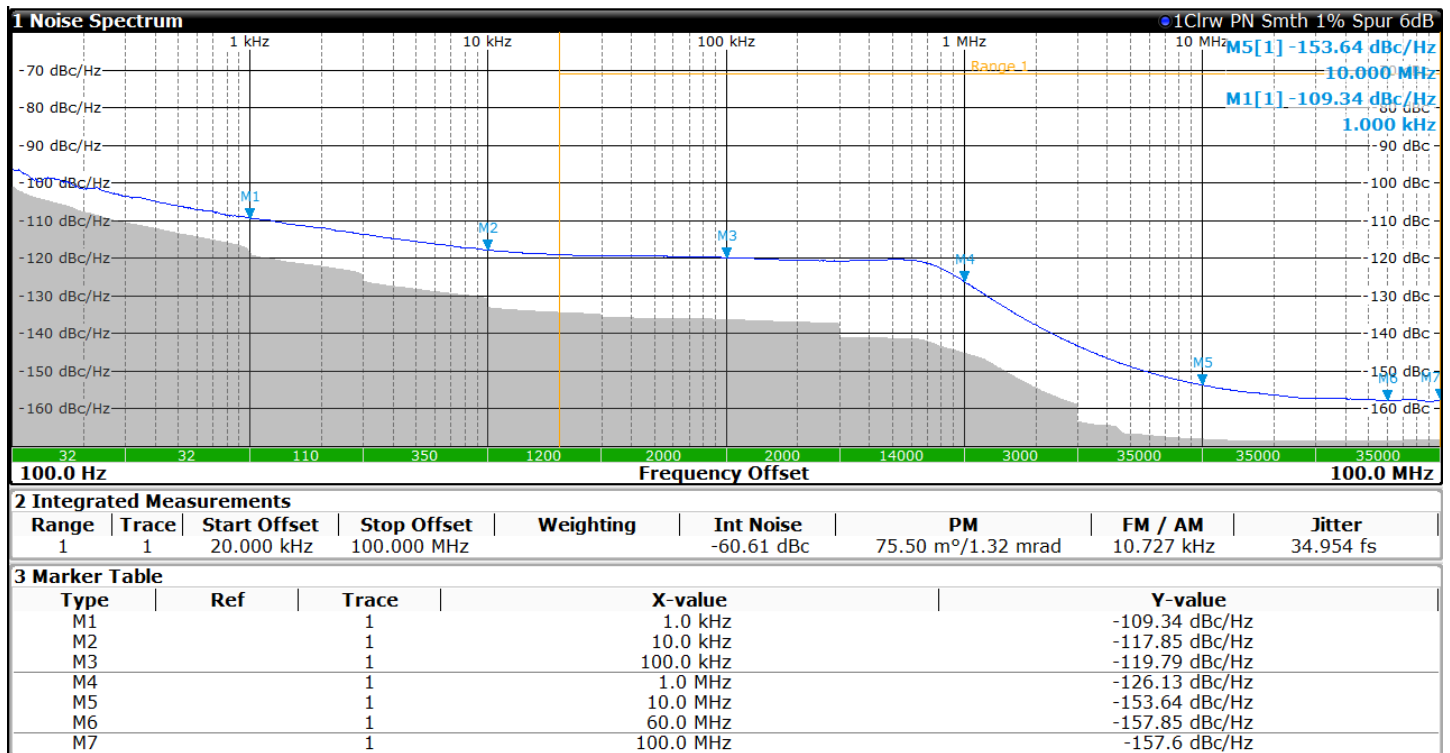
[c]  $N(1/f) = \Phi_N(\text{RF\_OUT}) - 10 \text{ Log}(10\text{kHz} \div f) - 20 \text{ Log}(f_{\text{RF\_OUT}} \div 1\text{GHz})$  where  $\Phi_N(1/f)$  is the 1/f noise contribution at a RF\_OUT frequency (f<sub>RF\_OUT</sub>) and at a frequency offset f.

# Typical Performance Characteristics

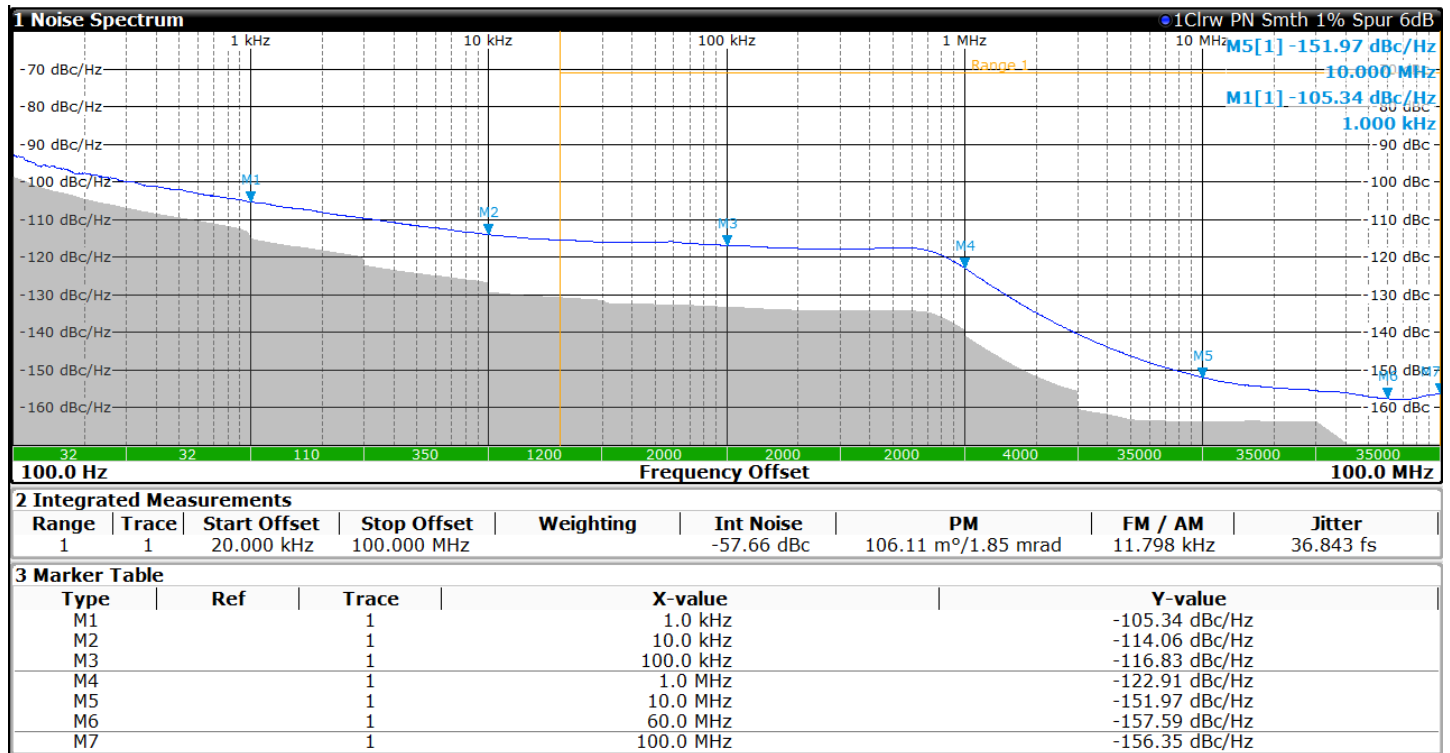
**Figure 2. Phase Noise at 6GHz (Fractional Mode)**



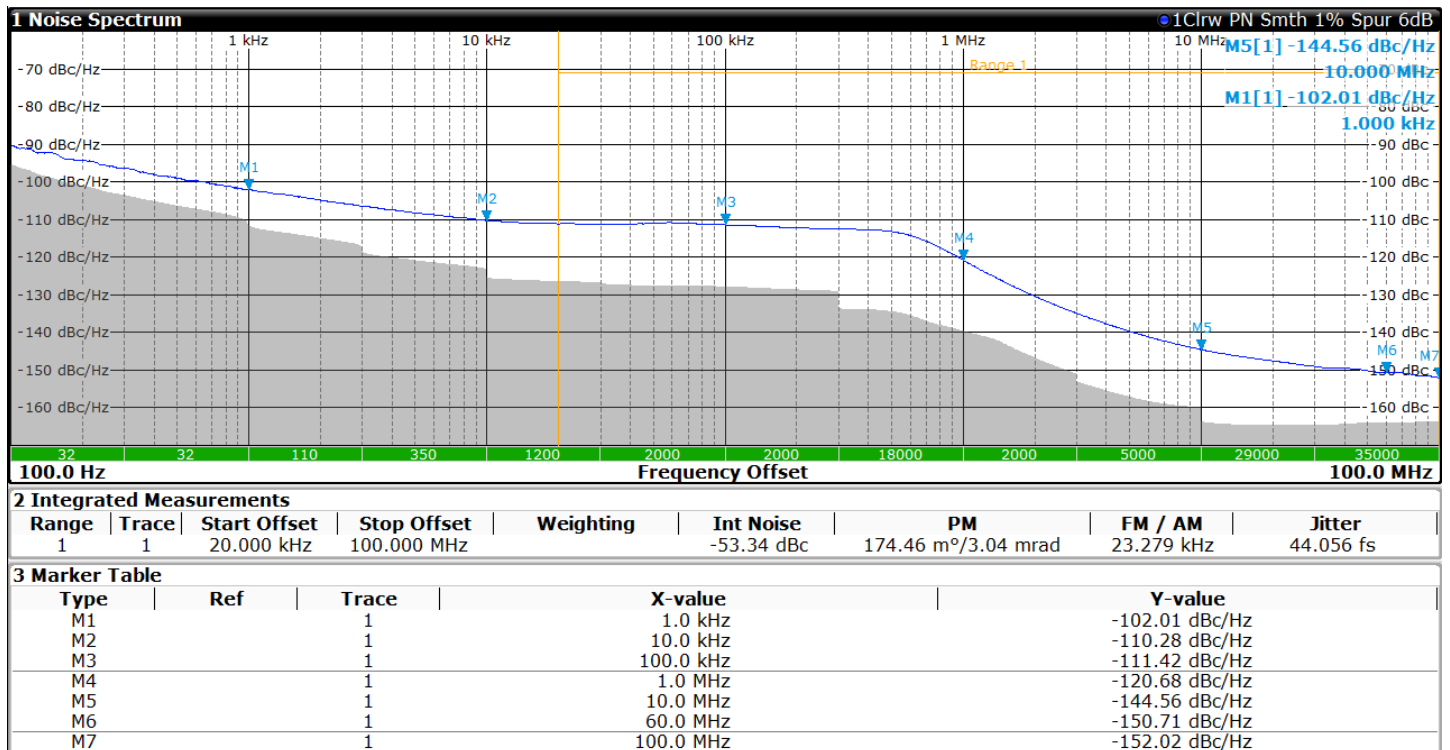
**Figure 3. Phase Noise at 6GHz (Integer Mode)**



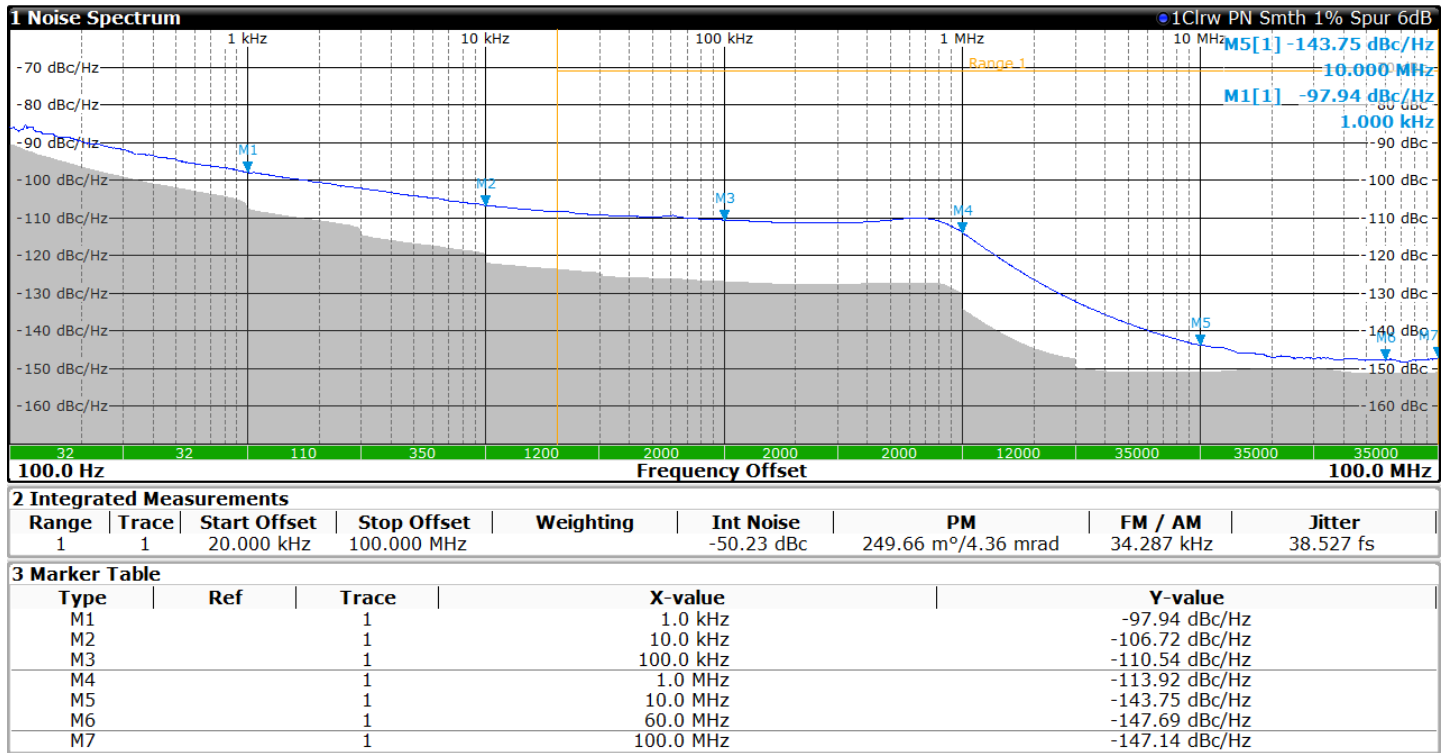
**Figure 4. Phase Noise at 8GHz (Integer Mode)**



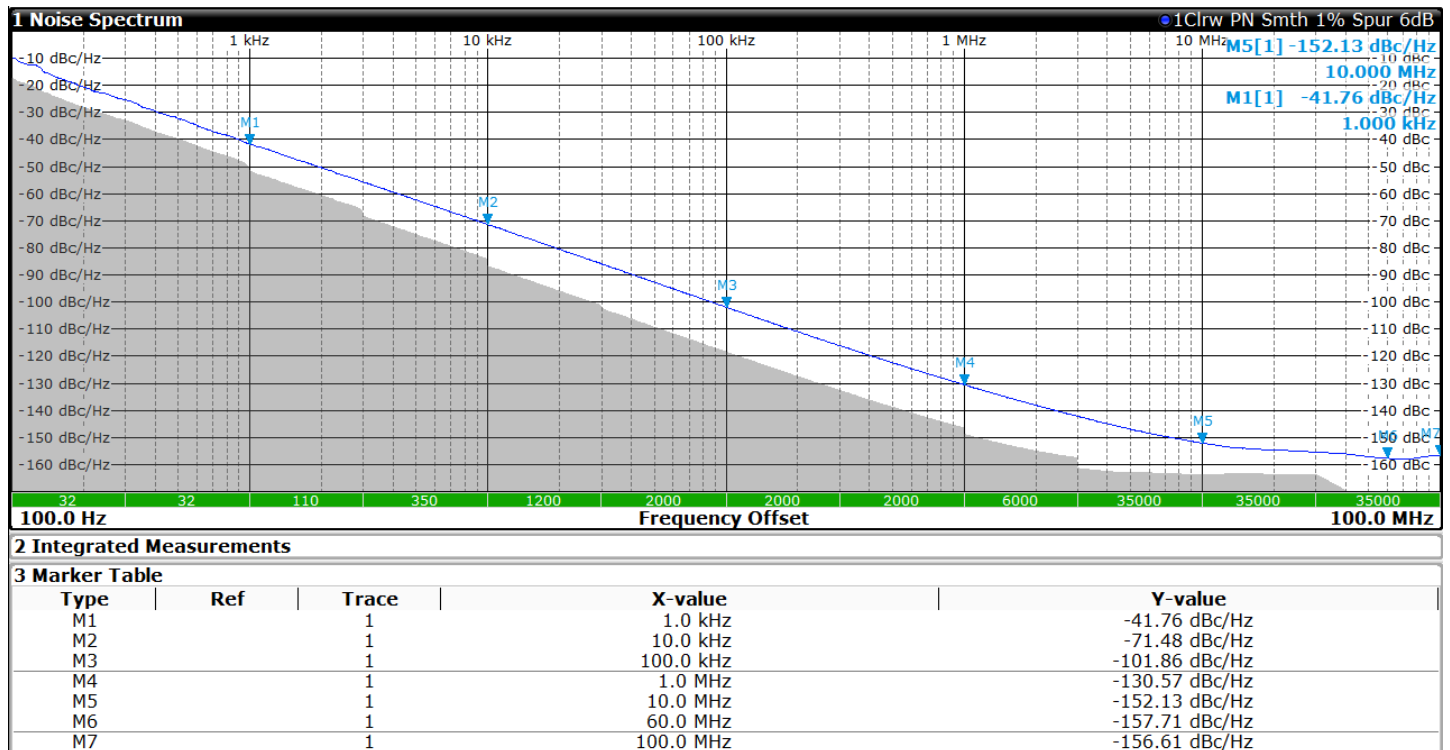
**Figure 5. Phase Noise at 11GHz (Integer Mode)**



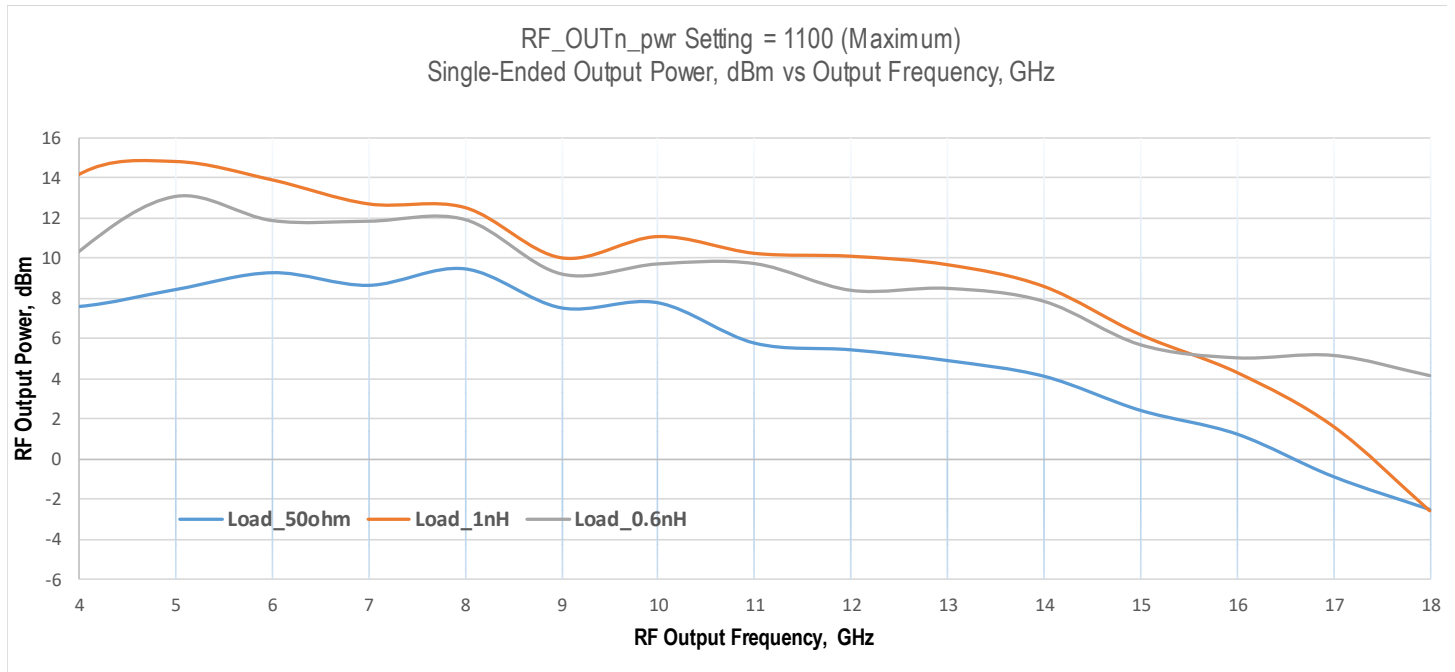
**Figure 6. Phase Noise at 18GHz (Integer Mode)**



**Figure 7. Phase Noise at 8GHz (Open Loop)**



**Figure 8. Typical Output Power vs. RF Output Frequency (Over Different Loads)**



## Theory of Operation

The 8V97003 is a high-performance frequency synthesizer with an integrated wideband VCO for wide frequency coverage. The VCO provides an octave frequency from 5.5GHz to 11GHz. An optional VCO-doubler is used to generate frequencies larger than the maximum VCO frequency (11GHz) up to 18GHz and an optional output divider can be used to divide the VCO frequency to an output frequency as low as 171.875 MHz. The input reference can support frequencies from 10MHz to 1600MHz. The phase detector (PFD) can support frequencies from 10MHz to 250MHz in fractional mode, and up to 500MHz in Integer mode. A Delta Sigma Modulator (DSM) controls the feedback divider of the PLL in order to create fractional N-divider values. The fractional numerator and the modulus are programmable to 32-bit long, allowing a very fine frequency resolution. The device provides two outputs with individually programmable RF output power (for more information, see [Table 55](#)). The digital logic is a 3- or 4-wire SPI interface that is 1.8V compatible and 3.3V tolerant.

## Synthesizer Programming

The Fractional-N divider architecture is implemented via a cascaded programmable dual modulus prescaler, controlled by a DSM. The N divider offers a division ratio in the feedback path of the Phase Lock Loop (PLL), and is given by programming the value of INT, FRAC, and MOD in the following equation:

$$N = INT + \text{FRAC}/\text{MOD}$$

where:

- *INT* is the divide ratio of the binary 16-bit counter (see [Table 25](#)).
- *FRAC* is the numerator value of the fractional divide ratio. It is programmable from 0 to (MOD – 1) (see [Table 25](#)).
- *MOD* is the 32-bit modulus. It is programmable from 2 to 4,294,967,295 (see [Table 25](#)).

The VCO frequency ( $f_{VCO}$ ) at RF\_OUTA or RF\_OUTB is given by the following equation:

$$f_{VCO} = f_{PFD} \times (INT + \text{FRAC}/\text{MOD}) \quad (1)$$

$f_{PFD}$  is the frequency at the input of the Phase and Frequency Detector (PFD).

The 8V97003 supports an Integer mode. It is enabled by programming the FRAC value to 0.

The device's VCO is separated into several frequency bands in order to cover the entire range with sufficient margin for process, voltage, and temperature variations. These are automatically selected by invoking the Autocal feature. The charge pump current is also programmable via the ICP\_SETTING register for maximum flexibility.

The [Output Control Registers](#) can be used to enable RF\_OUTA, or RF\_OUTB, or both outputs.

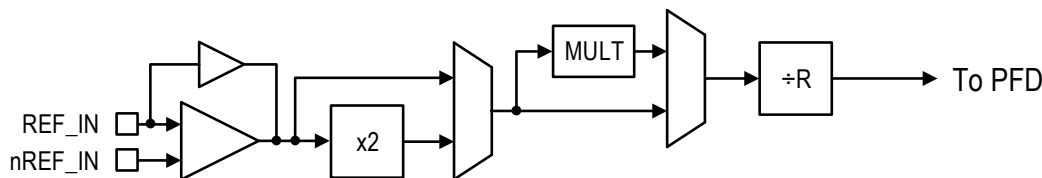
## Reference Input Stage

The 8V97003 features one differential reference clock input, REF\_IN. This differential input can also be configured as one single-ended input, and it can be driven by an AC-coupled sine wave or square wave.

The input type (Differential or Single-ended) can be programmed via the bit Input\_Type in the [Input Control Registers](#). In Power-down mode, this input is set to High-Impedance to prevent loading of the reference source.

The reference input signal path also includes a reference divider (R) and an optional doubler (D), as well as an optional multiplier (MULT) that allows accommodating a higher PFD frequency when the input reference frequency is low (see [Figure 9](#)). Having a high enough PFD frequency is typically better for phase noise performance. However, note that the MULT multiplier also adds its own additive noise. In both cases (doubler and / or multiplier enabled), the maximum PFD frequency is limited to 500MHz in Integer mode and to 250MHz in Fractional mode.

**Figure 9. Input Reference Path**



$$f_{\text{PFD}} = \text{REF}_{\text{CLK}} \times \frac{1+D}{R} \times \text{MULT}$$

- D is the input reference doubler (0 if not active, or 1 if active)
- MULT is the multiplication factor of the input Multiplier "MULT". It is equal to 1 if it is bypassed.

## Input Reference Divider (R)

A 10-bit input reference divider (R Divider) is available to scale the input reference frequency to a frequency suitable for the PFD.

## Reference Doubler

In order to improve the phase noise performance of the device, the reference doubler can be used. By using the doubler, the PFD frequency is also doubled to allow a more frequent update of the VCO, which may optimize the phase noise performance.

When operating the device in Fractional mode, the speed of the Sigma Delta modulator of the N counter is limited to 250MHz, which is also the maximum PFD frequency that can be used in fractional mode. When the part operates in integer-N mode, the PFD frequency is limited to 500MHz.

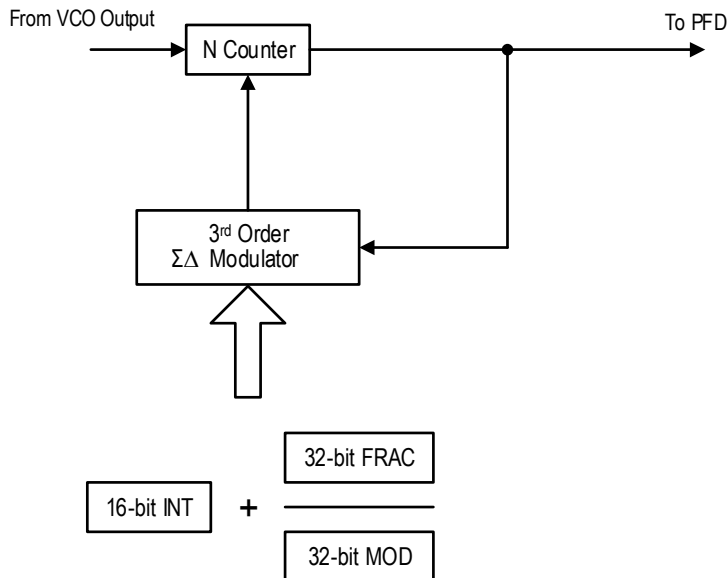
## Reference Multiplier (MULT)

The 8V97003 input path offers an optional frequency multiplier that can multiply the input reference frequency (or the frequency after the optional reference doubler D) to a frequency that must be between 160MHz and 250MHz. That multiplied frequency is used as the PFD frequency. When possible, enabling the doubler is recommended in order to provide a higher input frequency to the MULT multiplier, and thus, optimize its phase noise performance. When it is used, the optional MULT multiplier may degrade the in-band phase noise within the loop bandwidth of the 8V97003.

## Feedback Divider

The feedback divider N supports fractional division capability in the PLL feedback path. It consists in an integer N divider of 16 bits, and a Fractional divider of 32 bits (FRAC) over 32-bits (MOD).

**Figure 10. RF Feedback N Divider**



The 16 INT bits (NInt[15:0]) in the [Feedback Divider Control Registers](#) set the integer part of the feedback division ratio. The 32 FRAC bits (Bit NFrac[31:0]) in the registers set the numerator of the fraction that goes into the Sigma Delta modulator. The 32 MOD bits (NMod[31:0]) in the registers set the denominator of the fraction that goes into the Sigma Delta modulator.

From the relation (1), the VCO minimum step frequency is determined by  $(1/\text{MOD}) \times f_{\text{PFD}}$ .

FRAC values from 0 to (MOD - 1) cover channels over a frequency range equal to the PFD reference frequency. The PFD frequency is calculated as follows:

$$f_{\text{PFD}} = \text{REF}_{\text{CLK}} \times \frac{1 + D}{R}$$

- *REFCLK* is the input reference (REF\_IN) frequency
- *D* is the input reference doubler (0 if not active, or 1 if active)
- *R* is the 10-bit programmable input reference pre-divider

This formula assumes that the MULT input multiplier is bypassed.

The programmable modulus (MOD) is determined based on the input reference (REF\_IN) frequency and the desired channelization (or output frequency resolution). The high resolution provided on the R counter and the Modulus allows the user to choose from several configuration of the PLL to optimize the performance. The high resolution Modulus also allows the use of the same input reference frequency to achieve different channelization requirements. Using a unique PFD frequency for several needed channelization requirements allows the user to design a loop filter for the different needed setups and ensure the stability of the loop.

The channelization is given by  $\frac{f_{\text{PFD}}}{\text{MOD}}$

In low noise mode (dither disabled), the Sigma Delta modulator can generate some fractional spurs that are due to the quantization noise. The spurs are located at regular intervals equal to  $f_{PFD}/L$  where L is the repeat length of the code sequence in the Sigma Delta modulator. That repeat length depends on the MOD value, as described in Table 13.

**Table 13. Fractional Spurs Due to the Quantization Noise**

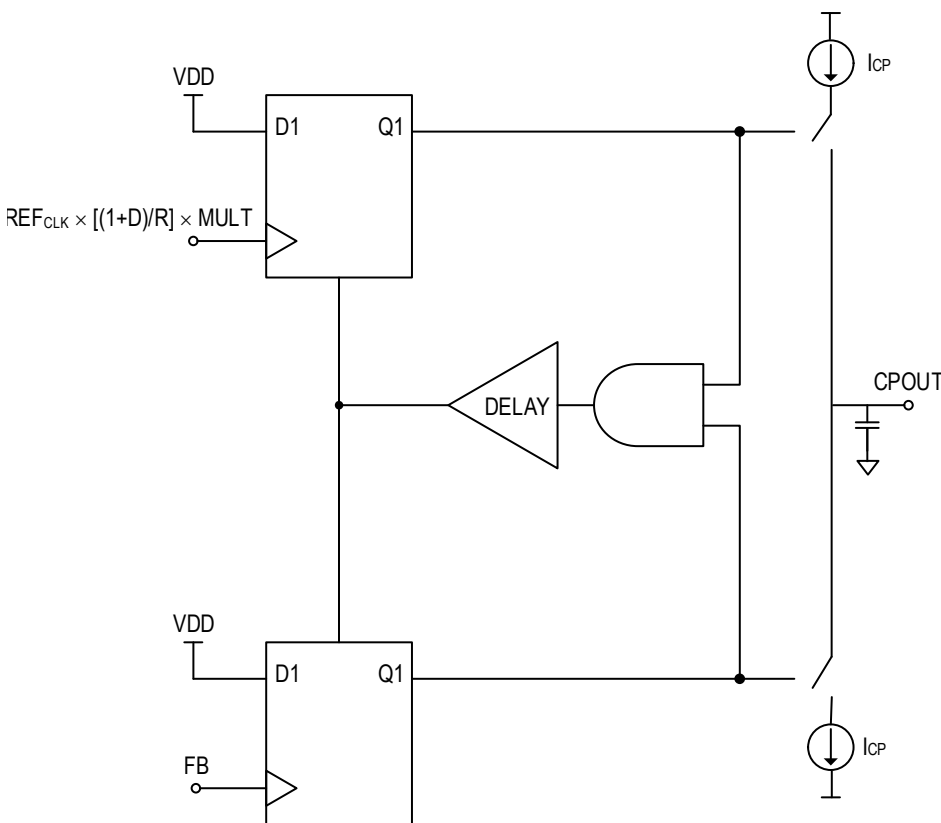
Condition (Dither Disabled)	L	Spur intervals
MOD can be divided by 2, but not by 3	$2 \times MOD$	$f_{PFD}/(2 \times MOD)$
MOD can be divided by 3, but not by 2	$3 \times MOD$	$f_{PFD}/(3 \times MOD)$
MOD can be divided by 6	$6 \times MOD$	$f_{PFD}/(6 \times MOD)$
Other conditions	MOD	$f_{PFD}/MOD$ (channel step)

In order to reduce the spurs, the user can enable the dither function to increase the repeat length of the code sequence in the Sigma Delta Modulator. The increased repeat length is  $2^{32} - 1$  cycles so that the resulting quantization error is spread to appear like broadband noise. As a result, the in-band phase noise may be degraded when using the dither function. When the application requires the lowest possible phase noise and when the loop bandwidth is low enough to filter most of the undesirable spurs, or if the spurs will not affect the system performance, it is recommended to use the low noise mode with dither disabled.

### Phase and Frequency Detector (PFD) and Charge Pump

The phase detector compares the outputs from the R counter and N counter, and generates an output corresponding to the phase and frequency difference between the two inputs at the PFD. The charge pump current is programmable through the serial port (SPI) to several different levels (see Table 49).

**Figure 11. Simplified PFD Circuit using D-type Flip-Flop**





## PFD Frequency

The operating frequency for the PFD is up to 500MHz when the device operates in integer mode, and up to 250MHz when the device operates in fractional mode.

## External Loop Filter

The 8V97003 requires an external loop filter. The design of that filter is application specific. For more information, see [Applications Information](#).

## Charge Pump High-Impedance

In order to put the charge pump into three-state mode, the user must set the bits CP\_HiZ (Bit D5) to 1 in Register 47 in the [Charge Pump Control Registers](#). This bit should be set to 0 for normal operation.

## Integrated Low Noise VCO

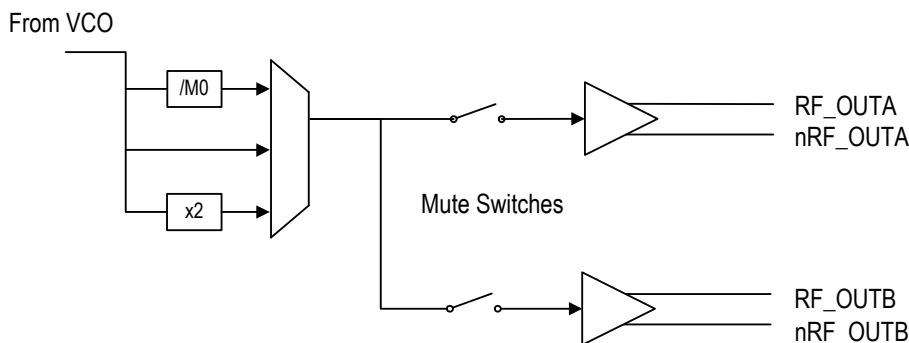
The VCO used in the 8V97003 is divided into several frequency bands. This allows for a lower VCO sensitivity ( $K_{vco}$ ), which results in the best possible VCO phase noise and spurious performance.

The user does not have to select the different VCO bands. The VCO band select logic of the 8V97003 will automatically select the most suitable band of operation at power up or after programming. In addition, the Force\_Relock bit (register 33, bit D7) can be used to automatically select the best frequency band.

## Output Clock Distribution and Optional Output Doubler

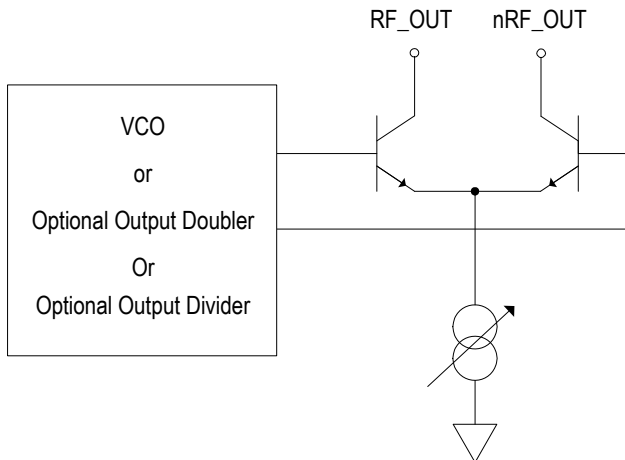
The 8V97003 device provides two differential outputs. Either of the two outputs generates a frequency equal to  $f_{VCO}$  when bypassing the optional output doubler and the optional output divider M0, or to  $2 \times f_{VCO}$  (up to 18GHz) when using the optional output doubler, or an integer division of the VCO frequency  $f_{VCO}$ . The division ratios of the output divider are provided in the [Output Control Registers](#).

**Figure 12. Output Clock Distribution**



RF\_OUT and nRF\_OUT are derived from the collector of an NPN differential pair driven by the VCO output (or the output doubler), as displayed in [Figure 13](#).

**Figure 13. Output Stage**



The 8V97003 offers 4 bits of programmability for the RF output power of each output. The user can configure the RF output power to multiple available settings (see [RF Output Power](#)).

If the auxiliary output (RF\_OUTB) is not used, it can be powered down by using the QB\_ena bit in the [Output Control Registers](#).

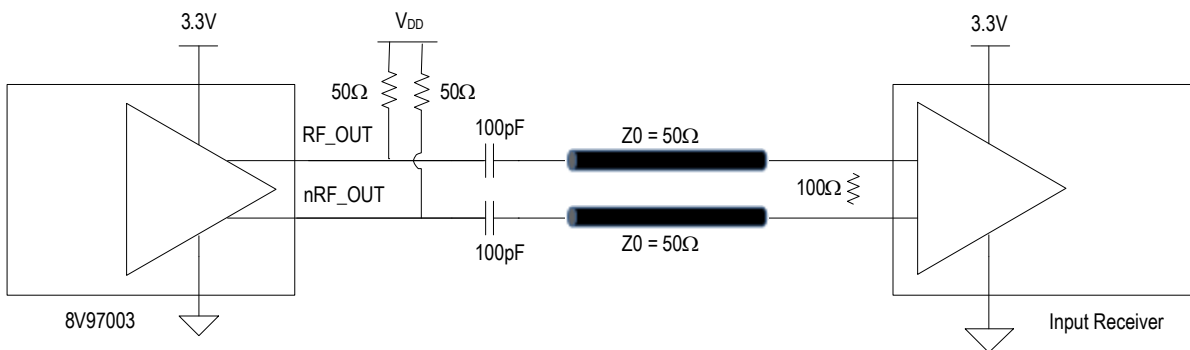
The outputs can be disabled until the part achieves lock. To enable this mode, the user will set the Mute\_until\_LD bit in the Outputs Control Registers (see [Output Control Registers](#)). The MUTE pin can be used to mute all outputs and be used as a similar function.

## Output Matching

The outputs of the 8V97003 are “open collector outputs” and can be matched in different ways.

A simple resistive matching is used to terminate the open collector RF\_OUT output with a 50Ω to VDD, and with an AC coupling capacitor in series. Two termination scheme examples are shown in [Figure 14](#) and [Figure 15](#). When considering the frequencies involved from the 8V97003, an inductively loaded configuration is recommended for better performance and optimal power transmission, and to minimize the distortion of the output signal. The resistive matching termination is not ideal to achieve maximum output power transmission, especially for high frequencies.

**Figure 14. Resistive Matching Termination**

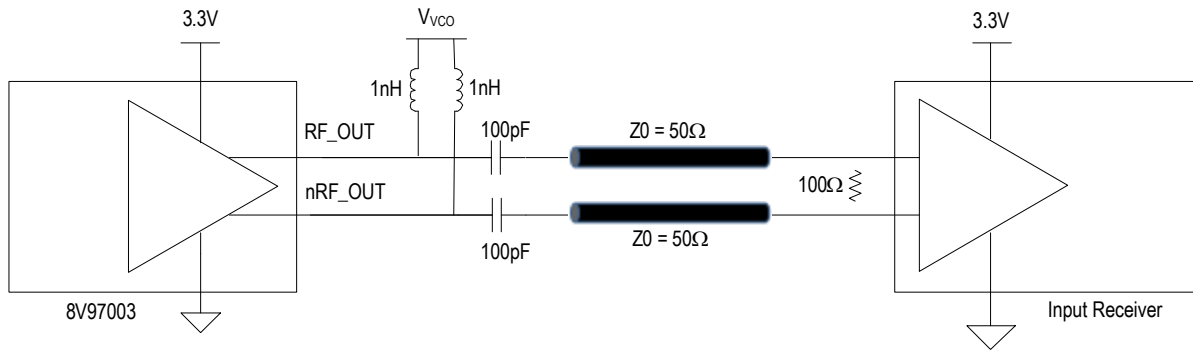


This termination scheme provides one of the selected output powers on the differential pair when connected to a 50Ω load. For additional information about the output power selection, see [RF Output Power](#).

The 50Ω resistor connected to VDD can also be replaced by a choke to provide better performance and optimal power transmission.

The pull-up inductor value is frequency dependent. For impedance matching of 50Ω, the inductance value can be calculated as  $L = 50 \div (2\pi f)$ , where “f” is the operating frequency. In this example, L = 1nH is for an operating frequency of approximately 6GHz.

**Figure 15. Inductively Loaded Termination**



For more recommendations on the termination scheme, see [Applications Information](#).

### Band Selection Disable

For a given frequency, the output phase can be adjusted when using the BandSelDisable bit (Bit D5 in Register 33; see [Calibration Control Registers](#)). When this bit is enabled (Bit D5 set to 1), the device does not complete a VCO band selection after changing the settings. When the Band\_Sel\_Disable bit is set to 0, and when the settings are updated, the device proceeds to a VCO band selection. The Band\_Sel\_Disable bit is useful when the user wants to make small changes in the output frequency (< 1MHz from the nominal frequency) without recalibrating the VCO and minimizing the settling time.

### Phase Adjust

The 8V97003 supports adjusting the phase delay between the outputs (RF\_OUT/ nRF\_OUT) and the input (REF\_IN) of the device by shifting the output phase by a fraction of the size of the fractional denominator, when the device is used in fractional mode.

Writing to the [Phase Adjustments Control Registers](#) triggers a phase shift (see [Table 28](#)). The phase adjustment value set by the bits, Phase[31:0], should be less than the fractional-N denominator register, MOD. The actual phase shift can be obtained with the following equation:

$$\text{Phase adjustment (degrees)} = 360 \times \frac{\text{Phase}}{\text{MOD}} \times \frac{T_{\text{PFD}}}{T_{\text{OUT}}}$$

or

$$\text{Phase adjustment (ns)} = T_{\text{FPD}} \times \left( \frac{\text{Phase}}{\text{MOD}} \right)$$

360° represents one cycle of output clock,  $T_{\text{PFD}}$  is the period at the input to the PFD (in ns),  $T_{\text{OUT}}$  is the period at the output of the 8V97003, and Phase is a programmable value, the same bit length as MOD.

### RF Output Power

Each output buffer RF\_OUTA and RF\_OUTB offers a configurable RF output power. The RF output power can be programmed via the bits RF\_OUTA\_pwr[3:0] and RF\_OUTB\_pwr[3:0] in the [Output Control Registers](#).

### Output Phase Synchronization

A synchronization event will result in a deterministic phase relationship between the output signal and the input reference.

The input to output phase relationship of the 8V97003 will be deterministic any time that the RF PLL(s) is in integer mode and the output divider is not used. The phase relationship is also deterministic when the input doubler or input multiplier is enabled.

When the RF PLL is in fractional mode, and/or when the input divider is enabled, the output phase of multiple 8V97003 devices can be synchronized. A synchronization pulse must be sent to all 8V97003 devices via the SYNC pins, and the Auto\_Sync bit must be set to 1. This synchronization pulse is timing critical and can be sent to the devices any time after the configuration is loaded.

The input clocks must be aligned at all REF\_IN inputs in order to support synchronization for multiple devices.

When the output divider is enabled, the 8V97003 does not support synchronization while the PLL is in either integer or fractional mode.

**Table 14. Timing Requirements**

Symbol	Parameter	Test Conditions	Minimum	Maximum	Unit
$t_s$	Setup Time	Rising edge of SYNC pulse to Rising Edge of REF_IN	0.5		ns
$t_H$	Hold Time	Rising Edge of REF_IN to Falling Edge of SYNC Pulse	0.5		ns

## Power-Down Mode

When power-down is activated, the following events occur:

1. VCO is not powered-down
2. RF\_OUT buffers are disabled
3. The input stage is powered down and set to High-Impedance
4. Input registers remain active and capable of loading and latching data

## Default Power-Up Conditions

All the RF outputs are muted at power-up. For default values in registers, see [Register Map](#).

## VCO Calibration

For proper VCO calibration, the 8V97003 must be programmed with the following recommended settings:

- The band select clock divider (Bits BndSelDiv[12:0] in the [Band Select Clock Divider Control Registers](#)) must be set to divide down the PFD frequency in between 50kHz to 100kHz ( $\text{PFD Frequency}/\text{BandSelDiv}[12:0] \leq 100\text{kHz}$  and  $> 50\text{kHz}$ ).
- BandSelAcc[1:0] bits must be set to 10 or 11.

## 3- or 4-Wire SPI Interface Description

The 8V97003 has a selectable 3/4-wire serial control port that can respond as a slave in an SPI configuration to allow read and write access to any of the internal registers for device programming or read back. The SPI interface consists of SCLK (clock), SDIO (serial data input and output in 3-wire mode, input in 4-wire mode), SDO (output in 4-wire mode), and CSB (chip select). A data transfer contains 16-bit instructions (direction +15 bit address) and any integer multiple of 8 bits data. Internal register data is organized in 8-bit byte.

### 3/4-Wire Mode

The 3- or 4-wire mode is defined by the SDO Active bit in the device configuration register 0x00 bit3 and bit4. If both bits are set to 0, the device is in a 3-wire mode and the SDIO pin is a bi-directional data input/ output, and the SDO pin is in high-impedance. Otherwise, the device is in a 4-wire mode, the SDIO pin is the data input, and the SDO pin is the data output.

### Active Clock Edge

SDIO is always clocked-in on the rising edge of SCLK. SDIO (or SDO if in 4-wire mode) is always clocked-out on the falling edge of SCLK.

## Reset

After power-up or reset by the nRESET pin, the SPI engine is reset and all internal registers reset to their default values. The SPI interface is in 3-wire mode with SDO in high-impedance, MSB-first mode, and address is in auto-decrement mode.

The function of SoftReset bit in register 0x00 bit7 and bit0 is similar to the nRESET pin. It resets all the registers to their default values, except registers 0x00 and 0x01.

## Least Significant Bit Position

The 8V97003 supports both the least significant bit first and most significant bit first transfers.

- If LSBFirst in register 0x00 bit6 and bit1 is set to 0, data is transferred in this order: transfer direction bit, the address bits A14 to A0, then first data byte D7 to D0, 2<sup>nd</sup> data byte D7 to D0, and so on until CSB is set to 1.
- If LSBFirst is set to 1, the order is: address bits A0 to A14, then the transfer direction bit, then the first data byte D0 to D7, 2<sup>nd</sup> data byte D0 to D7, and so on until CSB is set to 1.

By default, LSBFirst is set to 0.

## Addressing

The 8V97003 implements registers at the addresses from 0x00 to 0x49. The addressing mode is 15-bit.

During transferring operation, address increments automatically if AddressAcend in register 0x00 bit5 and bit2 is set to 1; otherwise it decrements. In incrementing mode, if address reaches 0x49, it wrap-around to 0x00. In decrementing mode, if address reaches 0x00, it wrap-around to 0x49.

By default, decrementing mode is set.

## Read Operation

A SPI operation starts when there is a high to low transition on CSB, and stops when there is a low to high transition on CSB. If the transfer direction bit R/nW is 1, it is a read operation; otherwise it is a write operation.

This device supports multi-byte read or write operations. Bits A14 to A0 refer to the register address. The device reads or writes data to this address and continues as long as CSB is held at low. The device automatically increments or decrements the address depending on AddressAcend bit.

[Figure 16](#) to [Figure 21](#) show the operation protocols.

## Mirrored Register Bits

In register 0x00, bits D7–D4 are mirrored with the bits D3–D0. The mirrored bits pair must set to the same value.

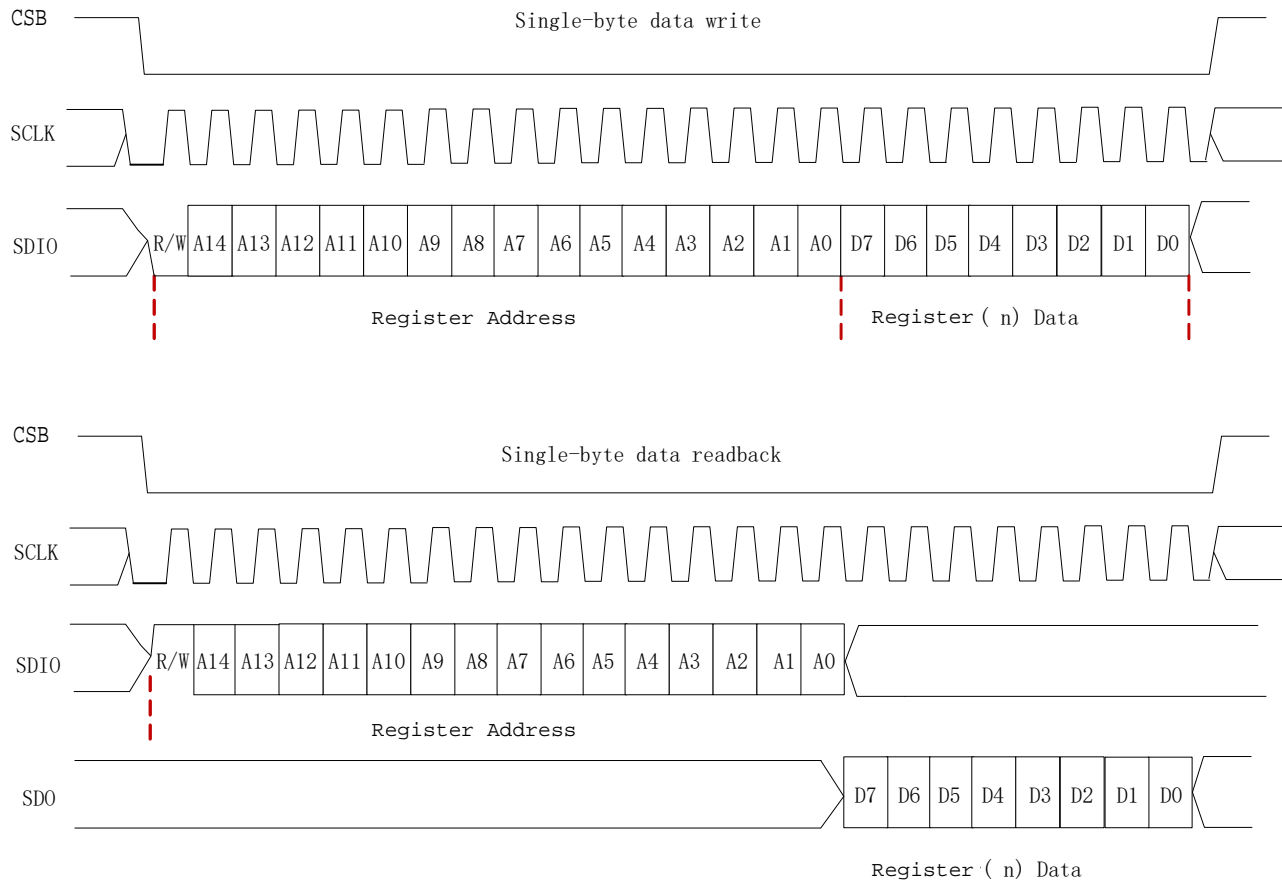
## Double-Buffered Registers

Configuration registers that are wider than 8 bits are double-buffered for synchronous access. For these registers, it is required to write the multiple-byte setting into the buffered registers first. The new configurations will not take effect until writing 1 to the TransferOn bit in register 0x0F bit0 to transfer them from the buffered registers to the active registers. TransferOn bit is self-clearing. Multiple-byte configuration data can be read-back either from buffered registers or active registers as specified by the BufferReadMode bit in register 0x01 bit5.

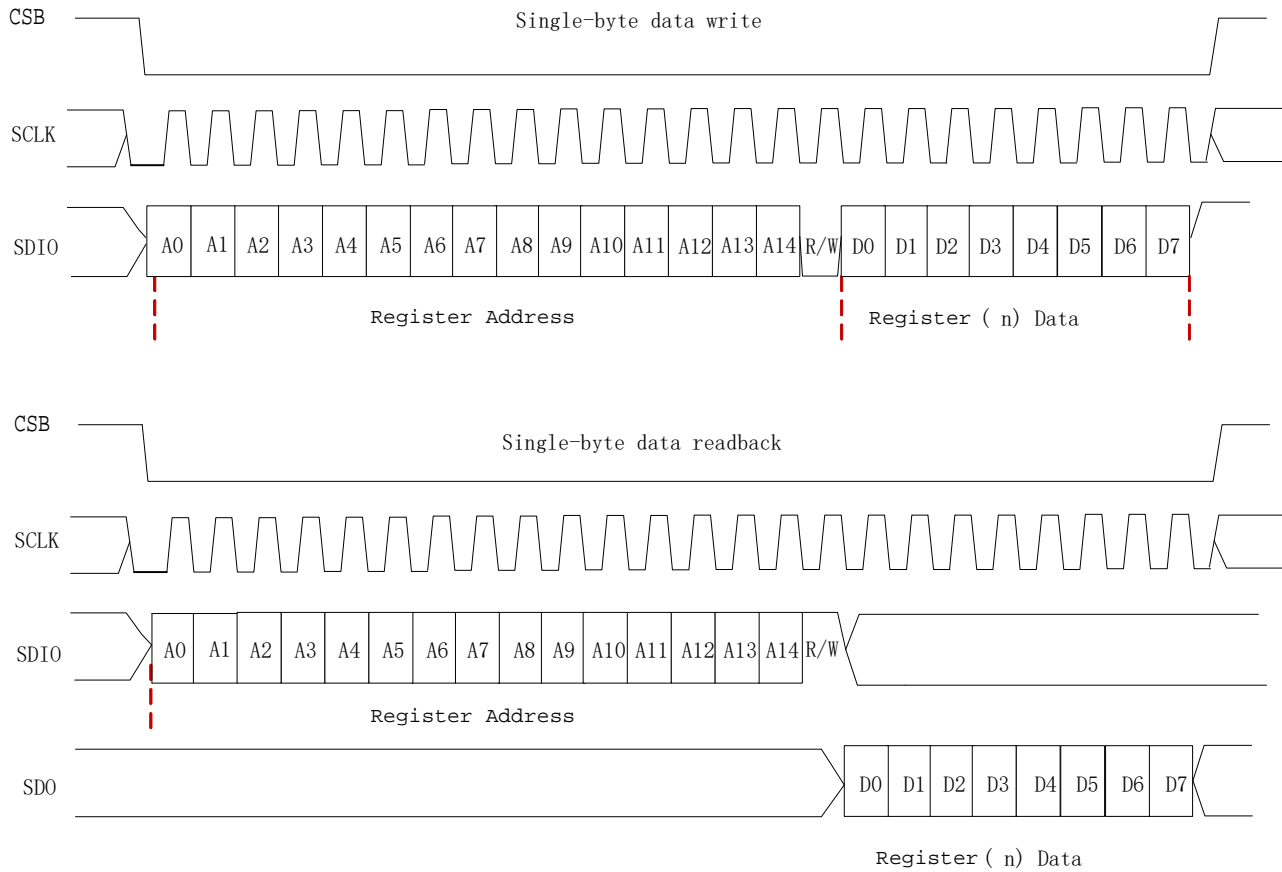
Register 0x10 to 0x1D, 0x22 to 0x25, and 0x29 to 0x2C are double buffered.

## Operation Protocols

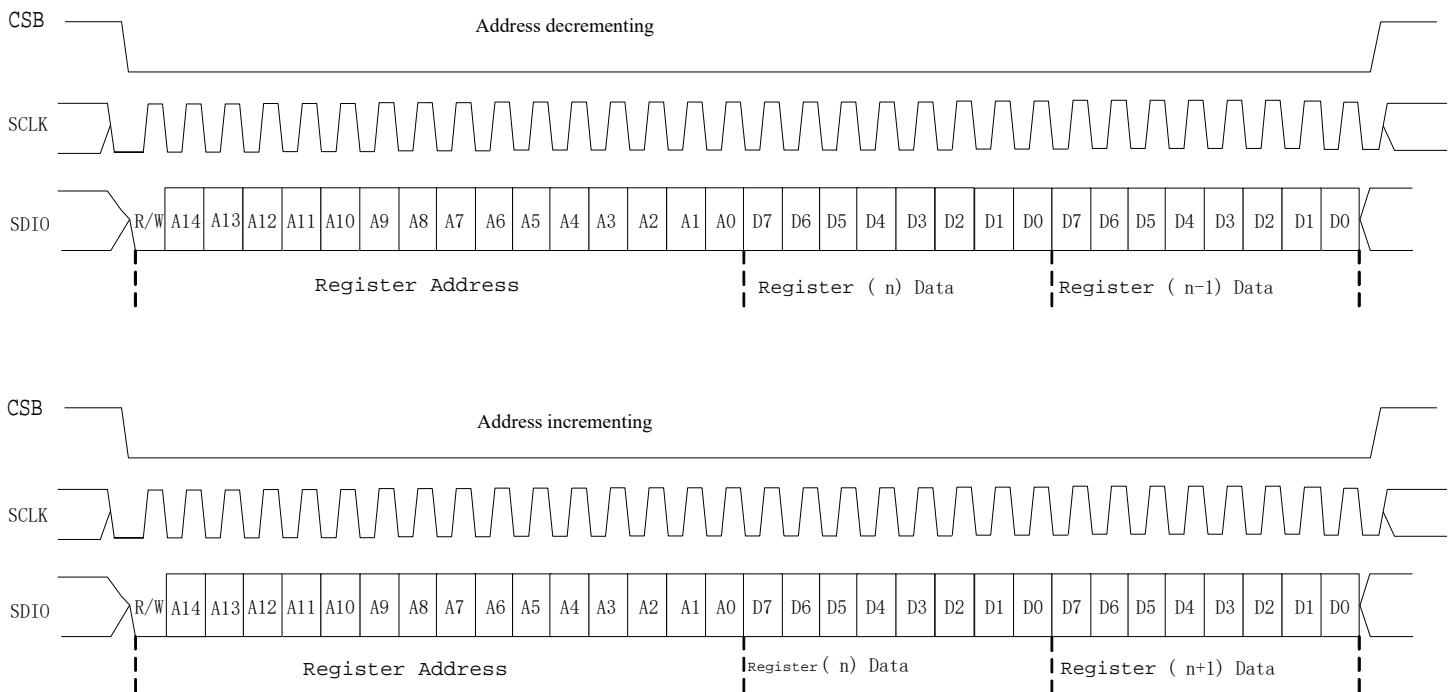
**Figure 16. 4-Wire MSB First, Single Byte Write and Read**



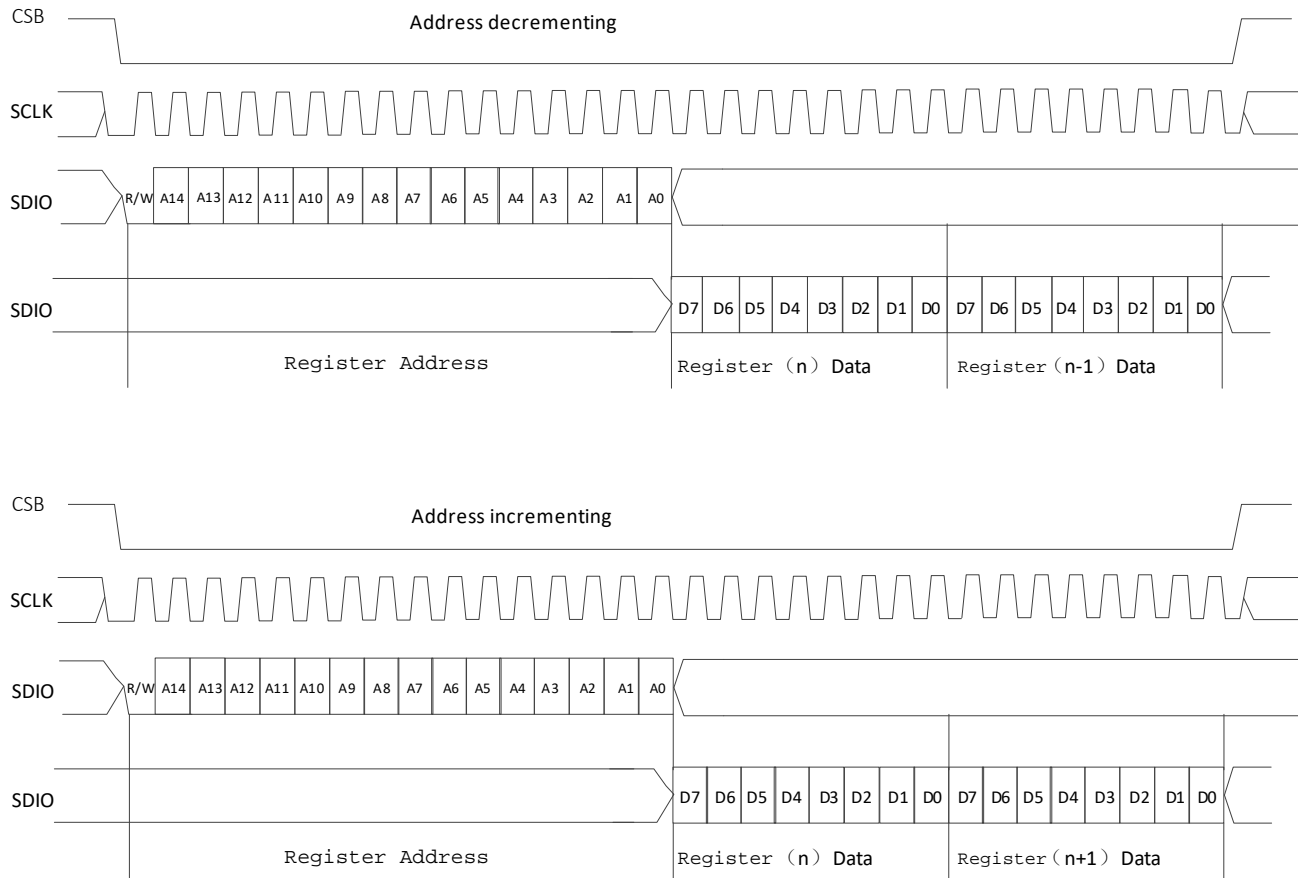
**Figure 17. 4-Wire LSB First, Single Byte Write and Read**



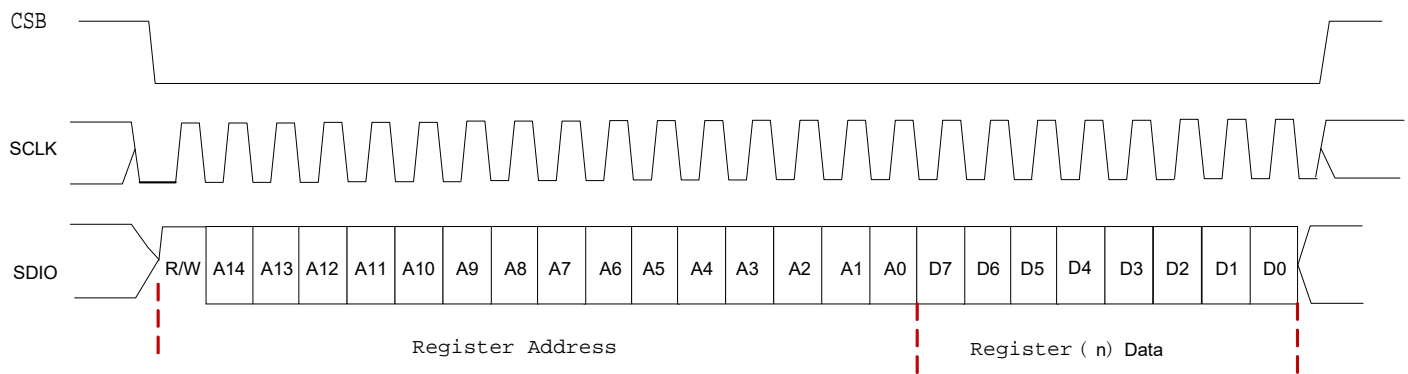
**Figure 18. 4-Wire MSB First, Multiple Bytes Write (2 Bytes Shown as Example)**



**Figure 19. 4-Wire LSB First, Multiple Bytes Read (2 Bytes Shown as Example)**

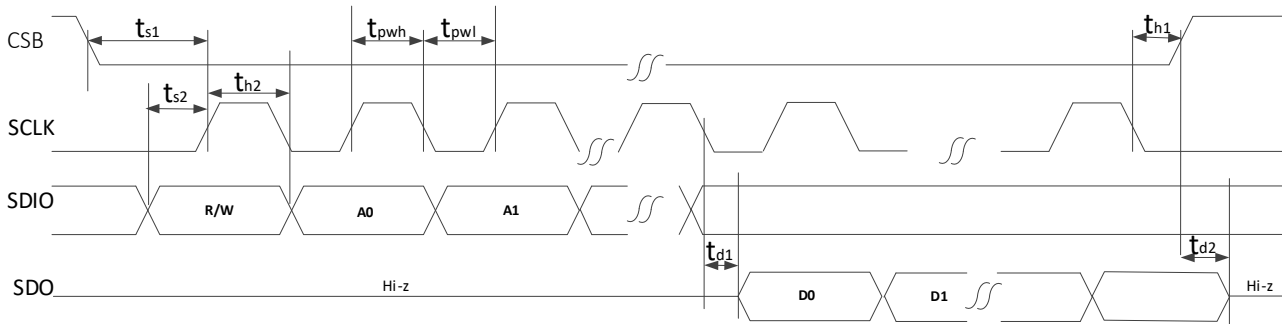


**Figure 20. 3-Wire MSB First, Single Byte Read and Write**





**Figure 21. SPI Timing Diagram**



**Table 15. SPI Read / Write Cycle Timing Parameters**

	Parameter	Minimum	Maximum	Units
$f_{SCLK}$	SCLK Frequency		20	MHz
$t_{pwh}$	SCLK High Pulse Width	25		ns
$t_{pwl}$	SCLK Low Pulse Width	25		ns
$t_{s1}$	Setup Time, CSB falling to SCLK rising	10		ns
$t_{h1}$	Hold Time, SCLK falling to CSB rising	30		ns
$t_{s2}$	Setup Time, SDIO input edge to SCLK rising	8		ns
$t_{h2}$	Hold Time, SCLK rising to SDIO input edge	8		ns
$t_{d1}$	SCLK Falling Edge to valid readback data on SDIO if in 3-wire mode, or SDO if in 4-wire mode		10	ns
$t_{d2}$	CSB Rising Edge to High-Impedance on SDIO if in 3-wire mode, or SDO if in 4-wire mode		10	ns

## Register Map

**Table 16. Preface Registers**

Register	Addr	Type	Default Value	D7	D6	D5	D4	D3	D2	D1	D0
0	0000	R/W	0000_0000	SoftReset	LSBFirst	AddressAscend	SDOActive	SDOActive	AddressAscend	LSBFirst	SoftReset
1	0001	R/W	0000_0000	Unused	Unused	BufferRead Mode	Unused	Unused	Unused	Unused	Unused
2	0002	R/W	0000_0000	Unused	Unused	Unused	Unused	Unused	Unused	Unused	Unused
3	0003	R	0000_0110	ChipType<7>	ChipType<6>	ChipType<5>	ChipType<4>	ChipType<3>	ChipType<2>	ChipType<1>	ChipType<0>
4	0004	R	0000_0000	ChipID<7>	ChipID<6>	ChipID<5>	ChipID<4>	ChipID<3>	ChipID<2>	ChipID<1>	ChipID<0>
5	0005	R	0000_0000	ChipID<15>	ChipID<14>	ChipID<13>	ChipID<12>	ChipID<11>	ChipID<10>	ChipID<9>	ChipID<8>
6	0006	R	0000_0000	ChipVersion<7>	ChipVersion<6>	ChipVersion<5>	ChipVersion<4>	ChipVersion<3>	ChipVersion<2>	ChipVersion<1>	ChipVersion<0>
7	0007	R	0001_0001	ChipOption<7>	ChipOption<6>	ChipOption<5>	ChipOption<4>	ChipOption<3>	ChipOption<2>	ChipOption<1>	ChipOption<0>
8	0008	R/W	0000_0000	Unused	Unused	Unused	Unused	Unused	Unused	Unused	Unused
9	0009	R/W	0000_0000	Unused	Unused	Unused	Unused	Unused	Unused	Unused	Unused
10	000A	R/W	0000_0000	Unused	Unused	Unused	Unused	Unused	Unused	Unused	Unused
11	000B	R/W	0000_0000	Unused	Unused	Unused	Unused	Unused	Unused	Unused	Unused
12	000C	R	0010_0110	VendorID<7>	VendorID<6>	VendorID<5>	VendorID<4>	VendorID<3>	VendorID<2>	VendorID<1>	VendorID<0>
13	000D	R	0000_0100	VendorID<15>	VendorID<14>	VendorID<13>	VendorID<12>	VendorID<11>	VendorID<10>	VendorID<9>	VendorID<8>
14	000E	R/W	0000_0000	Unused	Unused	Unused	Unused	Unused	Unused	Unused	Unused
15	000F	R/W	0000_0000	Unused	Unused	Unused	Unused	Unused	Unused	Unused	TransferOn

**Table 17. Control Registers<sup>[a]</sup>**

Register	Addr	Type	Default Value	D7	D6	D5	D4	D3	D2	D1	D0
16	0010	R/W	0001_1111	NInt<7>	NInt<6>	NInt<5>	NInt<4>	NInt<3>	NInt<2>	NInt<1>	NInt<0>
17	0011	R/W	0000_0000	NInt<15>	NInt<14>	NInt<13>	NInt<12>	NInt<11>	NInt<10>	NInt<9>	NInt<8>
18	0012	R/W	1000_0110	NFrac<7>	NFrac<6>	NFrac<5>	NFrac<4>	NFrac<3>	NFrac<2>	NFrac<1>	NFrac<0>
19	0013	R/W	1111_1110	NFrac<15>	NFrac<14>	NFrac<13>	NFrac<12>	NFrac<11>	NFrac<10>	NFrac<9>	NFrac<8>
20	0014	R/W	1111_1111	NFrac<23>	NFrac<22>	NFrac<21>	NFrac<20>	NFrac<19>	NFrac<18>	NFrac<17>	NFrac<16>
21	0015	R/W	1011_1100	NFrac<31>	NFrac<30>	NFrac<29>	NFrac<28>	NFrac<27>	NFrac<26>	NFrac<25>	NFrac<24>
22	0016	R/W	0000_0000	NMod<7>	NMod<6>	NMod<5>	NMod<4>	NMod<3>	NMod<2>	NMod<1>	NMod<0>
23	0017	R/W	1111_1110	NMod<15>	NMod<14>	NMod<13>	NMod<12>	NMod<11>	NMod<10>	NMod<9>	NMod<8>
24	0018	R/W	1111_1111	NMod<23>	NMod<22>	NMod<21>	NMod<20>	NMod<19>	NMod<18>	NMod<17>	NMod<16>
25	0019	R/W	1111_1111	NMod<31>	NMod<30>	NMod<29>	NMod<28>	NMod<27>	NMod<26>	NMod<25>	NMod<24>
26	001A	R/W	0000_0001	Phase<7>	Phase<6>	Phase<5>	Phase<4>	Phase<3>	Phase<2>	Phase<1>	Phase<0>
27	001B	R/W	0000_0000	Phase<15>	Phase<14>	Phase<13>	Phase<12>	Phase<11>	Phase<10>	Phase<9>	Phase<8>

**Table 17. Control Registers<sup>[a]</sup> (Cont.)**

Register	Addr	Type	Default Value	D7	D6	D5	D4	D3	D2	D1	D0
28	001C	R/W	0000_0000	Phase<23>	Phase<22>	Phase<21>	Phase<20>	Phase<19>	Phase<18>	Phase<17>	Phase<16>
29	001D	R/W	0000_0000	Phase<31>	Phase<30>	Phase<29>	Phase<28>	Phase<27>	Phase<26>	Phase<25>	Phase<24>
30	001E	R/W	0111_0010	0	DSMOrder<2>	DSMOrder<1>	DSMOrder<0>	DitherG<1>	DitherG<0>	ShapeDitherEn	DitherEn
31	001F	R/W	0000_1000	ManualBandEn	0	0	0	VCOManu<3>	VCOManu<2>	VCOManu<1>	VCOManu<0>
32	0020	R/W	0100_0000	Unused	BandManu<6>	BandManu<5>	BandManu<4>	BandManu<3>	BandManu<2>	BandManu<1>	BandManu<0>
33	0021	R/W	0000_0011	ForceRelock	PhAdj	BandSelDivisible	ManualResync	0	0	BandSelAcc<1>	BandSelAcc<0>
34	0022	R/W	0000_0000	BndSelDiv<7>	BndSelDiv<6>	BndSelDiv<5>	BndSelDiv<4>	BndSelDiv<3>	BndSelDiv<2>	BndSelDiv<1>	BndSelDiv<0>
35	0023	R/W	0000_1010	Unused	Unused	Unused	BndSelDiv<12>	BndSelDiv<11>	BndSelDiv<10>	BndSelDiv<9>	BndSelDiv<8>
36	0024	R/W	0000_0000	1	0	0	0	0	0	0	0
37	0025	R/W	0000_0000	0	0	0	0	0	0	0	0
38	0026	R/W	0000_0000	Unused	Unused	Unused	LD_Enable	AutoRecalEn	0	0	0
39	0027	R/W	0000_0000	Unused	Unused	LDPinMode<1>	LDPinMode<0>	Unused	LDP<2>	LDP<1>	LDP<0>
40	0028	R/W	0000_0001	vco_vreg_pwrdown	ref_vreg_pwrdown	pdcp_vreg_pwrdown	fb_vreg_pwrdown	outA_vreg_pwrdown	outBbuf_vreg_pwrdown	PDNAnaRegu	VCO_En
41	0029	R/W	0000_0001	R<7>	R<6>	R<5>	R<4>	R<3>	R<2>	R<1>	R<0>
42	002A	R/W	0000_1100	Unused	Unused	Unused	RefDouble_r_Delay	Input_Type	RefDouble_r_En	R<9>	R<8>
43	002B	R/W	0000_0000	Mult_En	Mult_reset	Mult<5>	Mult<4>	Mult<3>	Mult<2>	Mult<1>	Mult<0>
44	002C	R/W	0000_0000	nMultpwrwn<2>	nMultpwrwn<1>	nMultpwrwn<0>	Mult_force_vchi	Mult_force_vclow	1	0	0
45	002D	R/W	0001_1101	Unused	Unused	lcp_pmos<5>	lcp_pmos<4>	lcp_pmos<3>	lcp_pmos<2>	lcp_pmos<1>	lcp_pmos<0>
46	002E	R/W	0001_1101	Unused	Unused	lcp_nmos<5>	lcp_nmos<4>	lcp_nmos<3>	lcp_nmos<2>	lcp_nmos<1>	lcp_nmos<0>
47	002F	R/W	0000_0000	CP_HiZ	lcp_bleeder<6>	lcp_bleeder<5>	lcp_bleeder<4>	lcp_bleeder<3>	lcp_bleeder<2>	lcp_bleeder<1>	lcp_bleeder<0>
48	0030	R/W	0110_0010	Unused	Unused	Unused	Unused	pfd_pw<1>	pfd_pw<0>	1	Unused
49	0031	R/W	0000_0000	1	0	0	0	1	0	0	0
50	0032	R/W	0000_0000	AutoReSync	0	0	1	0	0	1	1
51	0033	R/W	0000_0000	Unused	Unused	Unused	Unused	RF_OUTA_pwr<3>	RF_OUTA_pwr<2>	RF_OUTA_pwr<1>	RF_OUTA_pwr<0>
52	0034	R/W	0000_1000	1	Unused	Mute_until_LD	RF_OUTA_ena	1	1	1	0
53	0035	R/W	0000_0000	Unused	Unused	Unused	Unused	RF_OUTB_pwr<3>	RF_OUTB_pwr<2>	RF_OUTB_pwr<1>	RF_OUTB_pwr<0>

**Table 17. Control Registers<sup>[a]</sup> (Cont.)**

Register	Addr	Type	Default Value	D7	D6	D5	D4	D3	D2	D1	D0
54	0036	R/W	0000_1000	1	Unused	Unused	RF_OUTB_ena	1	1	1	0
55	0037	R/W	0000_0000	Reserved	Reserved	Reserved	Reserved	Reserved	Reserved	Reserved	Reserved
56	0038	R/W	0000_0000	Reserved	Reserved	Reserved	Reserved	Reserved	Reserved	Reserved	Reserved
57	0039	R/W	0000_0000	Reserved	Reserved	Reserved	Reserved	Reserved	Reserved	Reserved	Reserved
58	003A	R/W	0000_0000	Reserved	Reserved	Reserved	Reserved	Reserved	Reserved	Reserved	Reserved
59	003B	R/W	0000_0000	OutDoubl _Ena	OutDivide _Ena	OutDoubl _Freq	Unused	Unused	OutDiv<2>	OutDiv<1>	OutDiv<0>
60	003C	R/W	0000_0000	Unused	Unused	Unused	Unused	0	0	1	0
61	003D	R/W	0000_0000	Unused	Unused	Unused	Reserved	Reserved	0	0	0
62	003E	R/W	0000_0000	Unused	Unused	Unused	Unused	Unused	Unused	Unused	Unused
63	003F	R/W	0000_0000	Unused	Unused	Unused	Unused	Unused	Unused	Unused	Reserved
64	0040	R/W	0000_0000	Reserved	Reserved	Reserved	Reserved	Reserved	Reserved	Reserved	Reserved
65	0041	R/W	0110_0010	0	1	1	0	Unused	Unused	1	0
66	0042	R/W	0010_0010	Unused	Unused	1	0	Unused	Unused	1	0
67	0043	R/W	0010_0010	Unused	Unused	1	0	Unused	Unused	1	0

[a] It is recommended to write 0 for Unused and Reserved bits when writing.

**Table 18. Status Registers**

Register	Addr	Type	Default Value	D7	D6	D5	D4	D3	D2	D1	D0
68	0044	R	0000_0000	DigLock	BandSelD one	Unused	Unused	VcoSts<3>	VcoSts<2>	VcoSts<1>	VcoSts<0>
69	0045	R	0000_0000	Unused	BandSts<6>	BandSts<5>	BandSts<4>	BandSts<3>	BandSts<2>	BandSts<1>	BandSts<0>
70	0046	R	0000_0000	0	0	0	0	0	0	0	0
71	0047	R	0000_0000	Unused	Unused	0	0	0	0	0	0
72	0048	R	0000_0000	Unused	Unused	Unused	Unused	Unused	Unused	Unused	Unused
73	0049	R/W	0000_0000	Unused	Unused	Unused	Unused	Unused	LossLock	Unused	Unused

## Register Block Descriptions

**Table 19. Register Block Descriptions**

	Register Blocks (Hex)	Register Block Descriptions
Preface Registers	0000–0001	Startup Control Registers
	0002	Reserved
	0003–0007	Device Type, ID Version, and Option Registers
	0008–000B	Unused
	000C–000D	Vendor ID Control Registers
	000E–000F	Unused
Control Registers	0010–0019	Feedback Divider Control Registers
	001A–001D	Phase Adjustments Control Registers
	001E	DSM Control Registers
	001F–0020	Manual VCO and Digital Band Selection
	0021	Calibration Control Registers
	0022–0023	Band Select Clock Divider Control Registers
	0024–0025	Reserved
	0026–0027	Lock Detect Control Registers
	0028	Power Down Control Registers
	0029–002C	Input Control Registers
	002D–002F	Charge Pump Current Control Registers
	0030	PFD Pulse Width Control Registers
	0031–0032	Re-Sync Control Registers
	0033–003B	Output Control Registers
	003C	Reserved
	003D	Reserved
	003E–0040	Unused or Reserved
	0041–0043	Reserved
Status Registers	0044	Digital Lock and Calibration and VCO Status Registers
	0045	Digital Band Status Registers
	0046–0048	Reserved or Unused
	0049	Loss of Lock Status Registers

## Preface Registers

**Table 20. Preface Register Block**

Register Blocks (Hex)	Register Block Descriptions
0000–0001	Startup Control Registers
0002	Reserved
0003–0006	Device Type, ID and Version Registers
0007	Reserved
0008–000B	Unused
000C 000D	Vendor ID Control Registers
000E–000F	Unused

**Table 21. Preface Register Bits**

Addr	D7	D6	D5	D4	D3	D2	D1	D0
0000	SoftReset	LSBFirst	AddressAscend	SDOActive	<SDOActive>	<AddressAscend>	<LSBFirst>	<SoftReset>
0001	Unused	Unused	BufferReadMode	Unused	Unused	Unused	Unused	Unused
0002	Unused	Unused	Unused	Unused	Unused	Unused	Unused	Unused
0003	ChipType<7>	ChipType<6>	ChipType<5>	ChipType<4>	ChipType<3>	ChipType<2>	ChipType<1>	ChipType<0>
0004	ChipID<7>	ChipID<6>	ChipID<5>	ChipID<4>	ChipID<3>	ChipID<2>	ChipID<1>	ChipID<0>
0005	ChipID<15>	ChipID<14>	ChipID<13>	ChipID<12>	ChipID<11>	ChipID<10>	ChipID<9>	ChipID<8>
0006	ChipVersion<7>	ChipVersion<6>	ChipVersion<5>	ChipVersion<4>	ChipVersion<3>	ChipVersion<2>	ChipVersion<1>	ChipVersion<0>
0007	ChipOption<7>	ChipOption<6>	ChipOption<5>	ChipOption<4>	ChipOption<3>	ChipOption<2>	ChipOption<1>	ChipOption<0>
0008	Unused	Unused	Unused	Unused	Unused	Unused	Unused	Unused
0009	Unused	Unused	Unused	Unused	Unused	Unused	Unused	Unused
000A	Unused	Unused	Unused	Unused	Unused	Unused	Unused	Unused
000B	Unused	Unused	Unused	Unused	Unused	Unused	Unused	Unused
000C	VendorID<7>	VendorID<6>	VendorID<5>	VendorID<4>	VendorID<3>	VendorID<2>	VendorID<1>	VendorID<0>
000D	VendorID<15>	VendorID<14>	VendorID<13>	VendorID<12>	VendorID<11>	VendorID<10>	VendorID<9>	VendorID<8>
000E	Unused	Unused	Unused	Unused	Unused	Unused	Unused	Unused
000F	Unused	Unused	Unused	Unused	Unused	Unused	Unused	TransferOn

**Table 22. Preface Register Description**

Bit Field Name	Field Type	Default (Binary)	Description
SoftReset <SoftReset>	R/W Auto-Clear	0	Soft Reset Function: 0 = Normal operation 1 = Register reset. The device loads the default values into the registers, 0002 - 00FF. The content of the register addresses 0000 and 0001 and the SPI engine are not reset. SoftReset bit D7 is mirrored with <SoftReset> in bit position D0. Register reset requires setting both SoftReset and <SoftReset> bits.
LSBFirst <LSBFirst>	R/W	0	Least Significant Bit Position: Defines the bit transmitted first in SPI transfers between slave and master. 0 = The most significant bit (D7) first 1 = The least significant bit (D0) first The LSBFirst bit D6 is mirrored with the <LSBFirst> in bit position D1. Changing LSBFirst to most significant bit requires setting both LSBFirst and <LSBFirst> bits.
AddressAscend <AddressAscend>	R/W	0	Address Ascend On: 0 = Address Ascend is off (addresses auto-decrement in streaming SPI mode) 1 = Address Ascend is on (addresses auto-increment in streaming SPI mode) The AddressAscend bit specifies whether addresses are incremented or decremented in streaming SPI transfers. The AddressAscend bit D5 is mirrored with the <AddressAscend> in bit position D2. Changing AddressAscend to "ON" requires setting both the AddressAscend and <AddressAscend> bits.
SDOActive <SDOActive>	R/W	0	SPI 3/4-Wire Mode: Selects the unidirectional or bidirectional data transfer mode for the SDIO pin. 0 = SPI 3-wire mode: – SDIO is the SPI bidirectional data I/O pin – SDO pin is not used and is in high-impedance 1 = SPI 4-wire mode – SDIO is the SPI data input pin – SDO is the SPI data output pin The SDOActive bit D4 is mirrored with <SDOActive> in bit position D3. Changing SDOActive to SPI 4-wire mode requires setting both the SDOActive and <SDOActive> bits.
BufferReadMode	R/W	0	Read Back Mode of the Buffer Registers: 0 = Read from active registers 1 = Read from the Buffer Register (case of Doubled Buffer Registers); If the register being read is not doubled buffered, a 1 value will read from the active register.
ChipType[7:0]	R only	0000 0110	Device (Chip) Type: Reads 00000110 (RF Synthesizer / PLL) after power-up and reset.

**Table 22. Preface Register Description (Cont.)**

Bit Field Name	Field Type	Default (Binary)	Description
ChipID[15:0]	R only	0000000000000001	Device (Chip) ID
ChipVersion[7:0]	R only	0000 0010	Device (Chip) Version
ChipOption[7:0]	R only	0001 0001	Device (Chip) Option
VendorID[15:0]	R only	0000 0100 0010 0110	Vendor ID: 0x0426 (Integrated Device Technology, IDT). Reads 0x0426 (IDT) after power-up and reset.
TransferOn	R/W Auto-Clear	0	Transfer On Function transfers the buffer registers values into the active registers: 1 = Transfer ON 0 = Transfer OFF This bit must be set 1 to transfer the contents of the buffers into the active registers. This bit is self-clearing; that is, it does not have to be set back to 0. When this bit is set to 1 (self-clearing), the device updates the active registers to the contents of the buffer registers simultaneously. This is done in order to avoid taking effect asynchronously during programming a multi-bit value (more than 8 bits) into several registers.

## Feedback Divider Control Registers

**Table 23. Feedback Divider Control Block**

Register Blocks (Hex)	Register Block Descriptions
0010–0019	Feedback Divider Control Registers

**Table 24. Feedback Divider Control Register Bits**

Addr	D7	D6	D5	D4	D3	D2	D1	D0
0010	NInt<7>	NInt<6>	NInt<5>	NInt<4>	NInt<3>	NInt<2>	NInt<1>	NInt<0>
0011	NInt<15>	NInt<14>	NInt<13>	NInt<12>	NInt<11>	NInt<10>	NInt<9>	NInt<8>
0012	NFrac<7>	NFrac<6>	NFrac<5>	NFrac<4>	NFrac<3>	NFrac<2>	NFrac<1>	NFrac<0>
0013	NFrac<15>	NFrac<14>	NFrac<13>	NFrac<12>	NFrac<11>	NFrac<10>	NFrac<9>	NFrac<8>
0014	NFrac<23>	NFrac<22>	NFrac<21>	NFrac<20>	NFrac<19>	NFrac<18>	NFrac<17>	NFrac<16>
0015	NFrac<31>	NFrac<30>	NFrac<29>	NFrac<28>	NFrac<27>	NFrac<26>	NFrac<25>	NFrac<24>
0016	NMod<7>	NMod<6>	NMod<5>	NMod<4>	NMod<3>	NMod<2>	NMod<1>	NMod<0>
0017	NMod<15>	NMod<14>	NMod<13>	NMod<12>	NMod<11>	NMod<10>	NMod<9>	NMod<8>
0018	NMod<23>	NMod<22>	NMod<21>	NMod<20>	NMod<19>	NMod<18>	NMod<17>	NMod<16>
0019	NMod<31>	NMod<30>	NMod<29>	NMod<28>	NMod<27>	NMod<26>	NMod<25>	NMod<24>



**Table 25. Feedback Divider Control Register Description**

Register Description			
Bit Field Name	Field Type	Default (Binary)	Description
Nint[15:0]	R/W	0000 0000 0001 1111 = d'31	FB Divider Integer Portion: Minimum divide ratio is 12 0000 0000 0000 0000 = Not allowed ... 0000 0000 0000 1011 = Not allowed 0000 0000 0000 0111 = 12 ... 0000 0000 0001 1111 = 31 (default) ... 1111 1111 1111 1111 = 65,535
Nfrac[31:0]	R/W	1011 1100 1111 1111 1111 1110 1000 0110 = d'3,170,893,446	FB Divider Fractional Portion <sup>[a]</sup> : 0000 0000 0000 0000 0000 0000 0000 0000 = d'0 ... 1011 1100 1111 1111 1111 1110 1000 0110 = d'3,170,893,446 (default) ... 1111 1111 1111 1111 1111 1111 1111 1111 = d'4,294,967,295
Nmod[31:0]	R/W	1111 1111 1111 1111 1111 1110 0000 0000 = d'4,294,966,784	FB divider Modulus Portion: 0000 0000 0000 0000 0000 0000 0000 0000 = Not allowed 0000 0000 0000 0000 0000 0000 0000 0001 = Not allowed 0000 0000 0000 0000 0000 0000 0000 0010 = d'2 ... 1111 1111 1111 1111 1111 1110 0000 0000 = d'4,294,966,784 (default) ... 1111 1111 1111 1111 1111 1111 1111 1111 = d'4,294,967,295

[a] Nfrac is the numerator value of the fractional divide ratio. It is programmable from 0 to (MOD -1).

## Phase Adjustments Control Registers

**Table 26. Phase Adjustments Control Register Block**

Register Blocks (Hex)	Register Block Descriptions
001A–001D	Phase Adjustments Control Registers

**Table 27. Phase Adjustments Control Register Bits**

Addr	D7	D6	D5	D4	D3	D2	D1	D0
001A	Phase<7>	Phase<6>	Phase<5>	Phase<4>	Phase<3>	Phase<2>	Phase<1>	Phase<0>
001B	Phase<15>	Phase<14>	Phase<13>	Phase<12>	Phase<11>	Phase<10>	Phase<9>	Phase<8>
001C	Phase<23>	Phase<22>	Phase<21>	Phase<20>	Phase<19>	Phase<18>	Phase<17>	Phase<16>
001D	Phase<31>	Phase<30>	Phase<29>	Phase<28>	Phase<27>	Phase<26>	Phase<25>	Phase<24>

**Table 28. Phase Adjustments Control Register Descriptions**

Register Description			
Bit Field Name	Field Type	Default (Binary)	Description
Phase[31:0]	R/W	0000 0000 0000 0000 0000 0000 0000 0001 = d'1	Phase Adjustments <sup>[a]</sup> 0000 0000 0000 0000 0000 0000 0000 0000 = d'0 0000 0000 0000 0000 0000 0000 0000 0001 = d'1 (default) ... 1111 1111 1111 1111 1111 1111 1111 1111 = d'4,294,967,295

[a] Phase adjustment (Phase value) must be less than the Modulus (Nmod value).

## DSM Control Registers

**Table 29. DSM Control Register Block**

Register Blocks (Hex)	Register Block Descriptions
001E	DSM Control Registers

**Table 30. DSM Control Register Bits**

Addr	D7	D6	D5	D4	D3	D2	D1	D0
001E	0	DSMOrder<2>	DSMOrder<1>	DSMOrder<0>	DitherG<1>	DitherG<0>	ShapeDitherEn	DitherEn

**Table 31. DSM Control Register Descriptions**

Register Description			
Bit Field Name	Field Type	Default (Binary)	Description
DSMOrder[2:0]	R/W	111	DSM Order 000 = OFF. The device operates in integer mode and the fractional part is ignored 001 = 1st order 010 = 2nd order 011 = 3rd order 100 = Reserved 101 = Reserved 110 = Reserved 111 = 4th order (MASH) or 3rd order (SSMF-II) (default)
DitherG[1:0]	R/W	00	Dither Gain 00 = LSB Dither (Recommended) (default) 01 = LSB x2 Dither 10 = LSB x4 Dither 11 = LSB x8 Dither
ShapeDitherEn	R/W	1	Shape Dither Enable 0 = Shaped dither disabled 1 = Shaped dither enabled
DitherEn	R/W	0	Dither Enable 0 = Dither off 1 = Dither on

## Calibration Control Registers

**Table 32. Calibration Control Register Block**

Register Blocks (Hex)	Register Block Descriptions
001F–0021	Calibration Control Registers

**Table 33. Calibration Control Register Bits**

Addr	D7	D6	D5	D4	D3	D2	D1	D0
001F	ManuBandEn	0	0	0	VCOManu<3>	VCOManu<2>	VCOManu<1>	VCOManu<0>
0020	0	BandManu<6>	BandManu<5>	BandManu<4>	BandManu<3>	BandManu<2>	BandManu<1>	BandManu<0>
0021	ForceRelock	PhAdj	BandSelDisable	ManualReSync	0	0	BandSelAcc<1>	BandSelAcc<0>

**Table 34. Calibration Control Register Descriptions**

Register Description			
Bit Field Name	Field Type	Default (Binary)	Description
ManuBandEn	R/W	0	Calibration Mode Enable 0 = Automatic VCO and Digital Band Selection 1 = Manual VCO and Digital Band Selection
VCOManu[3:0]	R/W	1000	Manual VCO Selection (when ManuBandEn=1) 0000 = VCO0 0001 = VCO1 ... 0111 = VCO7 1000 – 1111 = Unused
Bandmanu[6:0]	R/W	10000000	Manual Digital Band Selection (when ManuBandEn=1) 0000000 = Band 0000001 = Band1 ... 1111111 = Band127
ForceRelock	R/W	0	ForceRelock 0 = Normal operation (default) 1 = VCO forced to recalibrate. This bit is self-clearing. Note: When the PLL is used in integer mode, this bit must be set to 1 after programming the feedback divider value.
PhAdj	R/W	0	Phase Adjust Triggers 0 = Normal operation 1 = Trigger phase adjustment once. This bit is self-clearing.

**Table 34. Calibration Control Register Descriptions**

Register Description			
Bit Field Name	Field Type	Default (Binary)	Description
BandSelDisable	R/W	0	Band Select Disable This bit will prevent a VCO recalibration when registers 16:25 are written. 0 = VCO recalibrates when registers 16:25 are written 1 = VCO does not recalibrate when registers 16:25 are written
ManualReSync	R/W	0	Manual Re-Sync of PLL outputs 0 = Normal operation 1 = Sync the PLL output to a specific phase with the PFD reference as specified by Phase<31:0>. This bit is self-clearing.
BandSelAcc[1:0]	R/W	11	Band select/Calibration resolution 00 = Reserved 01 = Reserved 10 = 4x resolution 11 = 8x resolution (default)

## Band Select Clock Divider Control Registers

**Table 35. Band Select Clock Divider Control Register Block**

Register Blocks (Hex)	Register Block Descriptions
0022–0023	Band Select Clock Divider Control Registers

**Table 36. Band Select Clock Divider Control Register Bits**

Addr	D7	D6	D5	D4	D3	D2	D1	D0
0022	BndSelDiv<7>	BndSelDiv<6>	BndSelDiv<5>	BndSelDiv<4>	BndSelDiv<3>	BndSelDiv<2>	BndSelDiv<1>	BndSelDiv<0>
0023	Unused	Unused	Unused	BndSelDiv<12>	BndSelDiv<11>	BndSelDiv<10>	BndSelDiv<9>	BndSelDiv<8>

**Table 37. Band Select Clock Divider Control Register Descriptions**

Register Description			
Bit Field Name	Field Type	Default (Binary)	Description
BndSelDiv[12:0]	R/W	0 1010 0000 0000 = d'2,560	Band Select Clock Divider <sup>[a]</sup> 0 0000 0000 0000 = Not allowed 0 0000 0000 0001 = d'1 ... 0 1010 0000 0000 = d'2,560 (default) ... 1 1111 1111 1111 = d'8,192

[a] This value should be set so that  $F_{PFD} / \text{BndSelDiv}$  is < 100kHz and > 50kHz.

## Lock Detect Control Registers

**Table 38. Lock Detect Control Register Block**

Register Blocks (Hex)	Register Block Descriptions
0026–0027	Lock Detect Control Registers

**Table 39. Lock Detect Control Register Bits**

Addr	D7	D6	D5	D4	D3	D2	D1	D0
0026	Unused	Unused	Unused	LD_Disable	AutoRecalEn	0	0	0
0027	Unused	Unused	LDPinMode<1>	LDPinMode<0>	Unused	LDP<2>	LDP<1>	LDP<0>

**Table 40. Lock Detect Control Register Descriptions**

Register Description			
Bit Field Name	Field Type	Default (Binary)	Description
LD_Disable	R/W	0	Lock Detect Disable 0 = Disable lock detect circuitry (default) 1 = Enable lock detect circuitry
AutoRecalEn	R/W	0	Automatic Recalibration Enable 0 = Disable (default) 1 = Enable (an automatic recalibration occurs if an unlock on LD is detected)
LDPinMode[1:0]	R/W	00	LD Pin Mode 00 = Digital Lock Detect (default); Normal lock detector function 01 = Calibration done 10 = Low 11 = High
LDP[2:0]	R/W	000	Lock Detector Precision setting (ns) 000 = 0.375 (default) 001 = 0.75 010 = 1.5 011 = 2.4 100 = 5.2 101 = 5.2 110 = 8.5 111 = 8.5

## Power Down Control Registers

**Table 41. Power Down Control Register Block**

Register Blocks (Hex)	Register Block Descriptions
0028	Power Down Control Registers

**Table 42. Power Down Control Register Bits**

Addr	D7	D6	D5	D4	D3	D2	D1	D0
0028	vco_vreg_pwrdown	ref_vreg_pwrdown	pdcp_vreg_pwrdown	fb_vreg_pwrdown	outA_vreg_pwrdown	outBbuf_vreg_pwrdown	PDNAnaRegu	VCO_En

**Table 43. Power Down Control Register Descriptions**

Register Description			
Bit Field Name	Field Type	Default (Binary)	Description
vco_vreg_pwrdown	R/W	0	VCO Regulator Power Down Control 0 = Regulator enabled (default) 1 = Regulator powered down
ref_vreg_pwrdown	R/W	0	Reference Input Path Regulator Power Down Control 0 = Regulator enabled (default) 1 = Regulator powered down
pdcp_vreg_pwrdown	R/W	0	Phase Detector and Charge Pump Regulator Power Down Control 0 = Regulator enabled (default) 1 = Regulator powered down
fb_vreg_pwrdown	R/W	0	Feedback Divider Regulator Power Down Control 0 = Regulator enabled (default) 1 = Regulator powered down
outA_vreg_pwrdown	R/W	0	OutputA Regulator Power Down Control 0 = Regulator enabled (default) 1 = Regulator powered down
outBbuf_vreg_pwrdown	R/W	0	Power Down Control for output path regulator and outputB regulator 0 = Regulator enabled (default) 1 = Regulator powered down
PDNAnaRegu	R/W	0	Analog Regulators Power Down Control <sup>[a]</sup> 0 = Normal working mode (default) 1 = Power down all analog regulators
VCO_En	R/W	1	VCO Enable 0 = Disable all VCOs 1 = Normal mode

[a] A value of 1 in PDNAnaRegu will supersede the values set for vco\_vreg\_pwrdown, ref\_vreg\_pwrdown, pdcp\_vreg\_pwrdown, fb\_vreg\_pwrdown, and out\_vreg\_pwrdown.



## Input Control Registers

**Table 44. Input Control Register Block**

Register Blocks (Hex)	Register Block Descriptions
0029–002C	Input Control Registers

**Table 45. Input Control Register Bits**

Addr	D7	D6	D5	D4	D3	D2	D1	D0
0029	R<7>	R<6>	R<5>	R<4>	R<3>	R<2>	R<1>	R<0>
002A	Unused	Unused	Unused	RefDoubler_Delay	Input_Type	RefDoubler_En	R<9>	R<8>
002B	Mult_En	nMult_Reset	Mult<5>	Mult<4>	Mult<3>	Mult<2>	Mult<1>	Mult<0>
002C	Mult_mux_ena	Mult_d2s_ena	Mult_cp_ena	Mult_force_vchi	Mult_force_vclow	1	0	0

**Table 46. Input Control Register Descriptions**

Register Description			
Bit Field Name	Field Type	Default (Binary)	Description
R[9:0]	R/W	00 0000 0001 = d'1	Input reference divide value 00 0000 0000 = d'1 00 0000 0001 = d'1 (default) ... 11 1111 1111 = d'1023
RefDoubler_Delay	R/W	0	Selects the standard or extended pulse width delay for the input doubler. 0 = Standard pulse width (default). Use if the input reference frequency is > 50MHz. 1 = Extended pulse width for use with low frequencies (< 50MHz)
Input_Type	R/W	1	Input type: Selects either differential or single-ended input 0 = Single-ended input 1 = Differential input (default)
RefDoubler_En	R/W	1	Reference Doubler Enable Enables the Input Reference Doubler 0 = Input reference doubler disabled 1 = Input reference doubler enabled (default)
Mult_En	R/W	0	MULT Enable 0 = MULT not enabled 1 = MULT enabled

**Table 46. Input Control Register Descriptions (Cont.)**

Register Description			
Bit Field Name	Field Type	Default (Binary)	Description
Mult_reset	R/W	0	Resets the Reference Multiplier Block (MULT) 0 = Multiplier is active (default) 1 = Multiplier is reset <sup>[a]</sup>
Mult<5:0>	R/W	000000	Frequency multiplication factor for the input clock. When enabled, the multiplier block (Mult) multiplies the input frequency to a higher frequency for the phase detector. 000000 = Unused 000001 = Unused 000010 = Unused 000011 = Multiplication by 3 000100 = Multiplication by 4 ... 111111 = Multiplication by 63
Mult_mux_ena	R/W	0	Mux enable for the multiplier 0 = Multiplier mux is disabled (default) 1 = Multiplier mux is enabled
Mult_d2s_ena	R/W	0	Differential to single-ended block enable for the Multiplier 0 = Multiplier differential to single-ended block disabled (default) 1 = Multiplier differential to single-ended block enabled
Mult_cp_ena	R/W	0	Charge Pump enable for the multiplier 0 = Multiplier charge pump disabled (default) 1 = Multiplier charge pump enabled
Mult_force_vchi	R/W	0	Force Multiplier Control Voltage High 0 = Normal operation (default) 1 = Multiplier control voltage is charged to VDD
Mult_force_vclow	R/W	0	Force Multiplier Control Voltage Low <sup>[b]</sup> 0 = Normal operation (default) 1 = Multiplier control voltage is discharged to GND

[a] When Input Multiplier (MULT) is being used, it is recommended to program the device with proper MULT settings keeping Mult\_reset = 1 and toggle it to low (active), then transfer the data using TransferOn Bit (Register 15, Bit 0) for Doubled-buffered registers and re-lock the PLL (ForceRelock).

[b] If Input Multiplier is not used, it is recommended to program the Mult\_force\_vclow bit to 1 (High).

## Charge Pump Control Registers

**Table 47. Charge Pump Control Register Block**

Register Blocks (Hex)	Register Block Descriptions
002D–0030	Charge Pump Control Registers

**Table 48. Charge Pump Control Register Bits**

Addr	D7	D6	D5	D4	D3	D2	D1	D0
002D	Unused	Unused	lcp_pmos<5>	lcp_pmos<4>	lcp_pmos<3>	lcp_pmos<2>	lcp_pmos<1>	lcp_pmos<0>
002E	Unused	Unused	lcp_nmos<5>	lcp_nmos<4>	lcp_nmos<3>	lcp_nmos<2>	lcp_nmos<1>	lcp_nmos<0>
002F	CP_HiZ	lcp_bleeder<6>	lcp_bleeder<5>	lcp_bleeder<4>	lcp_bleeder<3>	lcp_bleeder<2>	lcp_bleeder<1>	lcp_bleeder<0>
0030	Unused	Unused	Unused	Unused	pdf_pw<1>	pdf_pw<0>	1	Unused

**Table 49. Charge Pump Control Register Descriptions**

Register Description			
Bit Field Name	Field Type	Default (Binary)	Description
lcp_pmos[5:0] <sup>[a]</sup>	R/W	01 1101	Charge Pump Pmos Current Setting 00 0000 = 166uA 00 0001 = 333uA ... 01 1101 = 5mA (default) ... 11 1111 = 10.66mA
lcp_nmos[5:0] <sup>[b]</sup>	R/W	01 1101	Charge Pump Nmos Current Setting 00 0000 = 166uA 00 0001 = 333uA ... 01 1101 = 5mA (default) ... 11 1111 = 10.66mA

**Table 49. Charge Pump Control Register Descriptions (Cont.)**

Register Description			
Bit Field Name	Field Type	Default (Binary)	Description
CP_HiZ	R/W	0	Charge Pump High-Impedance Control 0 = Charge pump active 1 = Charge pump high-impedance
Icp_bleeder[6:0] <sup>[c]</sup>	R/W	000 0000	Charge Pump Bleeder Current Setting 000 0000 = Off (0uA) (Default) 000 0001 = 20 uA 000 0010 = 40 uA ... 111 1111 = 2540 uA
pdf_pw<1:0>	R/W	00	PFD Pulse Width Setting 00 = 260ps (default) 01 = 348ps 10 = 487ps 11 = 583ps

[a]  $I_{CP\_pmos} = 166.66e - 6 \times (\text{binary value} + 1)$

[b]  $I_{CP\_pmos} = 166.66e - 6 \times (\text{binary value} + 1)$

[c]  $I_{CP\_bleeder} = 20e - 6 \times (\text{binary value})$

## Re-Sync Control Registers

**Table 50. Re-Sync Control Register Block**

Register Blocks (Hex)	Register Block Descriptions
0031-0032	Re-Sync Control Registers

**Table 51. Re-sync Control Register Bits**

Addr	D7	D6	D5	D4	D3	D2	D1	D0
0031	1	0	0	0	1	0	0	0
0032	AutoReSync	0	0	1	0	0	1	1

**Table 52. Re-sync Control Register Descriptions**

Register Description			
Bit Field Name	Field Type	Default (Binary)	Description
AutoReSync	R/W	0	Automatic Resync selects automatic synchronization mode 0 = The device will not sync the PLL output to a specific phase with the reference. 1 = The device will sync the PLL output to a specific phase with the reference after a re-lock condition.

## Output Control Registers

**Table 53. Output Control Register Block**

Register Blocks (Hex)	Register Block Descriptions
0033–003B	Outputs Control Registers

**Table 54. Output Control Register Bits**

Addr	D7	D6	D5	D4	D3	D2	D1	D0
0033	Unused	Unused	Unused	Unused	RF_OUTA_pwr<3>	RF_OUTA_pwr<2>	RF_OUTA_pwr<1>	RF_OUTA_pwr<0>
0034	1	Unused	Mute_until_LD	RF_OUTA_ena	1	1	1	0
0035	Unused	Unused	Unused	Unused	RF_OUTB_pwr<3>	RF_OUTB_pwr<2>	RF_OUTB_pwr<1>	RF_OUTB_pwr<0>
0036	1	Unused	Unused	RF_OUTB_ena	1	1	1	0
0037	Reserved	Reserved	Reserved	Reserved	Reserved	Reserved	Reserved	Reserved
0038	Reserved	Reserved	Reserved	Reserved	Reserved	Reserved	Reserved	Reserved
0039	Reserved	Reserved	Reserved	Reserved	Reserved	Reserved	Reserved	Reserved
003A	Reserved	Reserved	Reserved	Reserved	Reserved	Reserved	Reserved	Reserved
003B	OutDoubler_Ena	OutDivider_Ena	OutDoubler_Freq	Unused	Unused	OutDiv<2>	OutDiv<1>	OutDiv<0>

**Table 55. Output Control Register Descriptions**

Register Description			
Bit Field Name	Field Type	Default (Binary)	Description
RF_OUTA_pwr[3:0]	R/W	0000	RF_OUTA Power Setting Set the output power for RF_OUTA. Higher setting number provides more output power up to a maximum value, depending on the output loading used. 0000 = OFF (default) 0001 = Minimum output power setting 1100–1111: Maximum output power setting
Mute_until_LD	R/W	0	Mute until Lock Detect selection 0 = Outputs are enabled independent of Lock Detect (default) 1 = Outputs are enabled only when Lock Detect is high
RF_OUTA_ena	R/W	0	RF_OUTA Enable 0 = RF_OUTA is disabled (MUTED) 1 = RF_OUTA is enabled

**Table 55. Output Control Register Descriptions (Cont.)**

Register Description			
Bit Field Name	Field Type	Default (Binary)	Description
RF_OUTB_pwr[3:0]	R/W	0000	RF_OUTB Power Setting Set the output power for RF_OUTB. Higher setting number provides more output power up to a maximum value, depending on the output loading used. 0000 = OFF (Default) 0001 = Minimum output power setting 1100–1111: Maximum output power setting
RF_OUTB_ena	R/W	0	RF_OUTB Enable 0 = RF_OUTB is disabled (MUTED) 1 = RF_OUTB is enabled
OutDoubler_Ena	R/W	0	RF Output Doubler Enable <sup>[a]</sup> 0 = 1x path (Divide by 1) path Enabled (default) <sup>[b]</sup> 1 = 2x path Enabled (RF Output Doubler Enabled)
OutDivider_Ena	R/W	0	RF Output Divider Enable 0 = 1x or 2x path Enabled (default) 1 = RF Output Divider Enabled Note: The output divider M0 can only be used (OutDivider_Ena=1) if the output doubler is disabled (OutDoubler_Ena=0). <sup>[c]</sup>
OutDoubler_Freq	R/W	1	RF Output Doubler Frequency Setting 0 = Use this setting for VCO frequency = 7.0-9.0GHz (default) 1 = Use this setting for VCO frequency = 5.5-7.0GHz
OutDiv[2:0]	R/W	000	RF Output Divider (M0) Settings 000 = Unused 001 = Div By 2 010 = Div By 4 011 = Div By 8 100 = Div By 16 101 = Div By 32 110 = Unused 111 = Unused

[a] OutDoubler\_Ena can only be set to 1 if the VCO frequency is not greater than 9GHz.

[b] For Divide by 1 (Output Divider and Doubler bypassed), both OutDoubler\_Ena Bit and Out\_Divider\_Ena bit must be set 0 (Low).

[c] Both the OutDoubler\_Ena and Out\_Divider\_Ena bits must not be set 1 (High) at the same time.

## Status Registers

**Table 56. Status Register Block**

Register Blocks (Hex)	Register Block Descriptions
0044	Digital Lock and Calibration and VCO Status Registers
0045	Digital Band Status Registers
0046–0047	Reserved
0048	Unused
0049	Loss of Lock Status Registers

**Table 57. Status Register Bits**

Addr	D7	D6	D5	D4	D3	D2	D1	D0
0044	DigLock	BandSelDone	Unused	Unused	VcoSts<3>	VcoSts<2>	VcoSts<1>	VcoSts<0>
0045	Unused	BandSts<6>	BandSts<5>	BandSts<4>	BandSts<3>	BandSts<2>	BandSts<1>	BandSts<0>
0046	0	0	0	0	0	0	0	0
0047	Unused	Unused	0	0	0	0	0	0
0048	Unused	Unused	Unused	Unused	Unused	Unused	Unused	Unused
0049	Unused	Unused	Unused	Unused	Unused	LossLock	Unused	Unused

**Table 58. Status Register Descriptions**

Register Description			
Bit Field Name	Field Type	Default (Binary)	Description
DigLock	R	0	Digital Lock 0 = PLL not locked 1 = PLL locked (according to LDP settings in Register 39)
BandSelDone	R	0	Band Select Done (calibration completed) 0 = Band selection not completed 1 = Band selection completed
VcoSts[3:0]	R	0000	Status bits reporting the current VCO 0000 = VCO0 0001 = VCO1 ... 0111 = VCO7 1000–1111 = Unused
BandSts[6:0]	R	000 0000	Status bits reporting the current digital band 000 0000 = Band0 000 0001 = Band1 ... 111 1111 = Band127

**Table 58. Status Register Descriptions (Cont.)**

Register Description			
Bit Field Name	Field Type	Default (Binary)	Description
LossLock	R/W1C	0	Status bit stating device loss of lock Sticky bit. Write 1 to this bit to clear 0 = Locked since last time register was cleared 1 = Loss of Lock since last time register was cleared

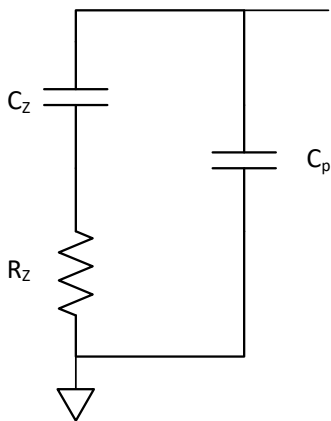
## Applications Information

### Loop Filter Calculations

#### 2<sup>nd</sup> Order Loop Filter

This section provides design information for a 2<sup>nd</sup> order loop filter for the 8V97003. A general 2<sup>nd</sup> order loop filter is shown in [Figure 22](#). Step-by-step calculations to determine R<sub>Z</sub>, C<sub>Z</sub>, and C<sub>P</sub> values for a desired loop bandwidth are described below. Required parameters are provided. A spreadsheet for calculating the loop filter values is also available.

**Figure 22. Typical 2<sup>nd</sup> Order Loop Filter**



1. Determine desired loop bandwidth f<sub>c</sub>.
2. Calculate R<sub>Z</sub>:

$$R_Z = \frac{2 \times \pi \times f_c \times N}{I_{CP} \times K_{VCO}}$$

Where,

- I<sub>CP</sub> is charge pump current. I<sub>CP</sub> is programmable from 167μA to 10.667mA.
- N is effective feedback divider. N must be programmed into the following value.

$$N = \frac{F_{VCO}}{F_{PD}}$$

- f<sub>VCO</sub> is VCO frequency. VCO frequency range: 5500 to 11000MHz



- $f_{PFD}$  is phase detector input frequency.

$$f_{PFD} = \frac{f_{REF}}{P_V}$$

- $f_{REF}$  is reference clock (REF\_IN) input frequency.
- $P_V$  is overall pre-divider or input doubler setting.
- $K_{VCO}$  is VCO gain depends on VCO Frequency (see VCO gain in

is VCO gain.  $K_{vco} = 90\text{MHz/V}$ .

3. Calculate  $C_Z$ :

$$C_Z = \frac{\alpha}{2 \times \pi \times f_c \times R_Z}$$

Where,

- $\alpha = f_c / f_z$ , user can determine an  $\alpha$  number.
- $\alpha > 6$  is recommended.

$f_z$  is frequency at zero.

4. Calculate  $C_P$ :

$$C_P = \frac{C_Z}{\alpha \times \beta}$$

Where,

- $\beta = f_p / f_c$ , user can determine  $\beta$  number.
- $\beta > 4$  is recommended.

$f_p$  is frequency at pole.

5. Verify Phase Margin ( $PM$ ).

$$PM = \arctan\left(\frac{b-1}{2 \times \sqrt{b}}\right)$$

Where,

$$b = 1 + \frac{C_Z}{C_P}$$

The phase margin (PM) should be greater than  $50^\circ$ .

A spreadsheet for calculating the loop filter component values is available at [www.IDT.com](http://www.IDT.com). To use the spreadsheet, simply enter the following parameters:

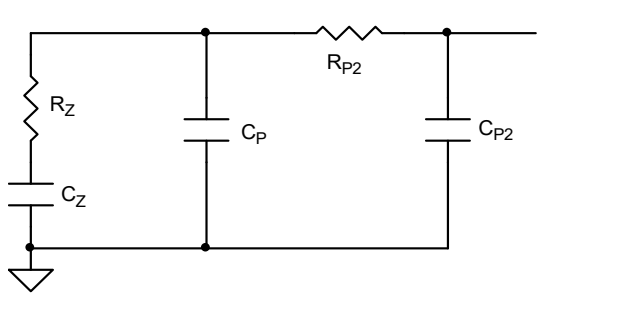
$f_c$ ,  $F_{ref}$ ,  $P_V$ ,  $I_{cp}$ ,  $F_{VCO}$ ,  $\alpha$ , and  $\beta$ .

The spreadsheet will provide the component values,  $R_z$ ,  $C_z$ , and  $C_p$  as the result. The spreadsheet also calculates the maximum phase margin for verification.

### 3<sup>rd</sup> Order Loop Filter

This section provides design information for a 3<sup>rd</sup> order loop filter for the 8V97003. A general 3<sup>rd</sup> order loop filter is shown in [Figure 23](#).

**Figure 23. Typical 3<sup>rd</sup> Order Loop Filter**



The R<sub>Z</sub>, C<sub>Z</sub>, and C<sub>P</sub> can be calculated as 2<sup>nd</sup> order loop filter. The following equation helps determine the 3<sup>rd</sup> order loop filter R<sub>P2</sub> and C<sub>P2</sub>.

Pick an R<sub>P2</sub> value. R<sub>P2</sub> ~ 1.5xR<sub>Z</sub> is suggested.

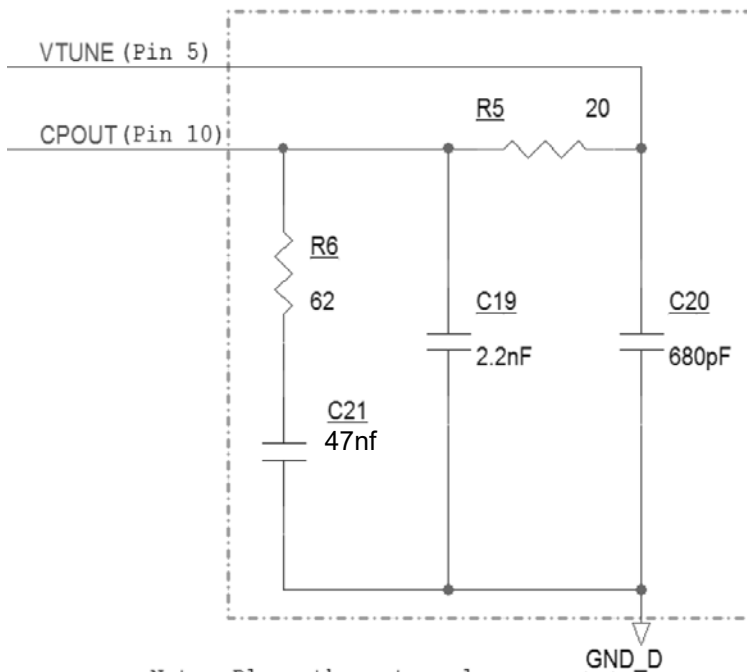
$$C_{P2} = \frac{R_Z * C_P}{R_{P2} * \gamma}$$

Where,

- $\gamma$  is ratio between the 1<sup>st</sup> pole frequency and the 2<sup>nd</sup> pole frequency.
- $\gamma > 4$  is recommended.

[Figure 24](#) shows an example of a loop filter that can be used on the 8V97003.

**Figure 24. Loop Filter Example**



Note: Place the external loop filter circuit as close to DUT as possible

## Recommendations for Unused Input and Output Pins

### Inputs

#### *LVTMOS Control Pins*

All control pins have internal pullup and pulldown resistors; additional resistance is not required but can be added for additional protection. A 1k $\Omega$  resistor can be used.

### Outputs

#### *Output Pins*

For any unused output, it can be left floating and disabled.

## Schematic Example

Figure 25 shows a general application schematic example for the 8V97003.

For power rails, bypass capacitors must be provided to all power supply pins. At least one bypass capacitor per power pin is suggested. Value can range from 0.01 $\mu$ F or 0.1 $\mu$ F. Mix values of bypass capacitors can help filtering wider range of power supply noise.

The 8V97003 input is high impedance. The input termination depends on the termination requirement from the driver. There are two input termination examples in the schematic shown in Figure 25; both are designed for transmission line with characteristic impedance  $Z_0 = 50\Omega$ .

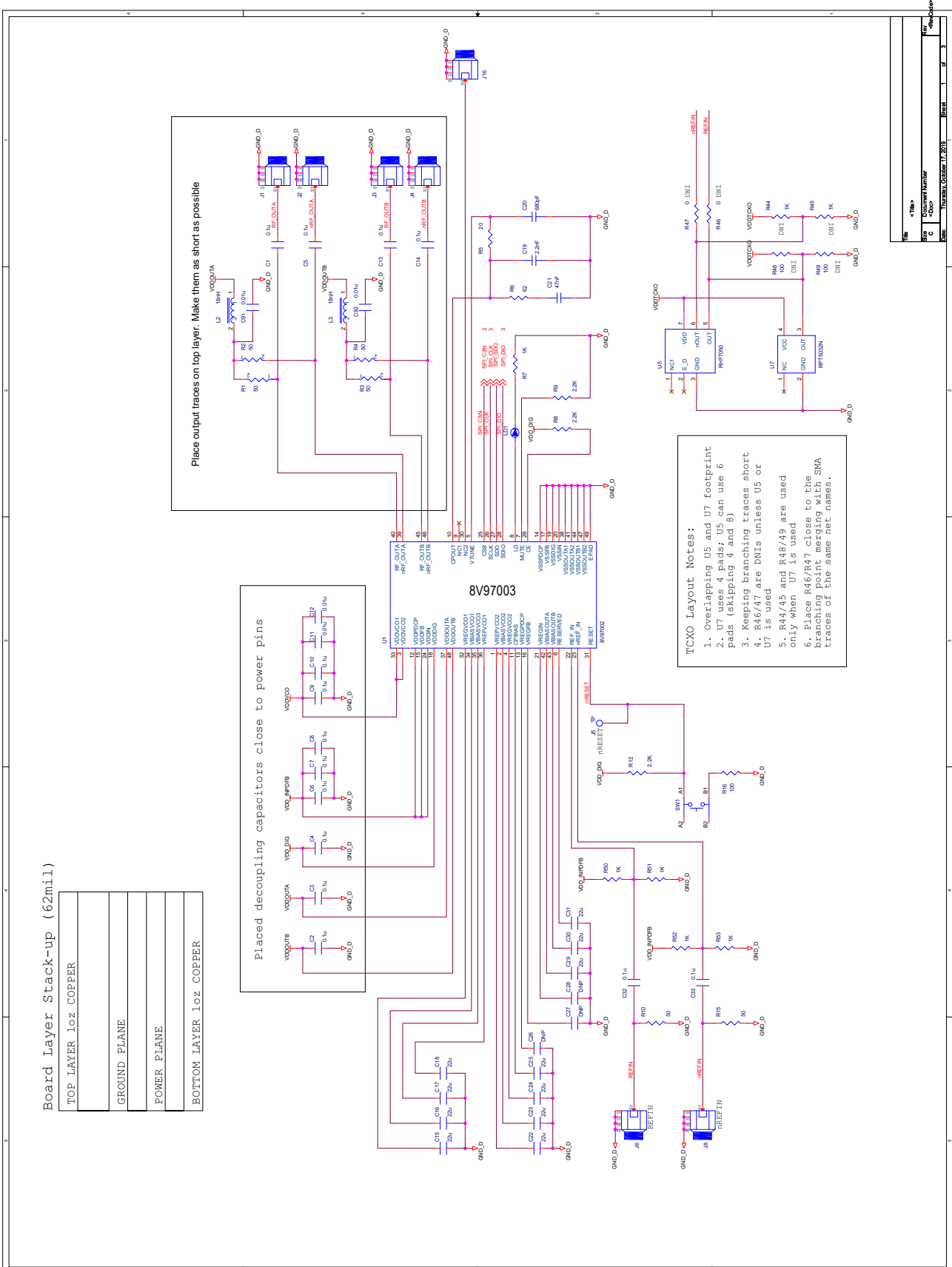
The first example, labeled "Input Reference" at the lower right corner of the schematic, shows an input termination scheme for accepting a reference clock from bench signal generators. 50 $\Omega$  resistors, R82 and R83 to GND, present matched loads to signal generator's source impedance; the reference clock signal is then AC-coupled with capacitors C156 and C157 to ensure proper DC-biased to level of  $V_{DDx}/2$  by voltage divider networks of R90, R91, R92, and R93. The second example shows an input termination scheme for accepting a reference clock from a TCXO. The values of R96, R96, R85, and R88 in this example are designed for a TCXO with a single-ended CMOS output on pin 5. They can be changed for different TCXO output signal types.

The 8V97003 output pull-up loading can be resistors or inductors. For inductor pull-up loading, the inductor value is frequency dependent. One inductor value cannot cover all the output frequency range. For example, an inductance of  $L = 1.3\text{nH}$  that is suitable for approximately 6GHz operating frequency. The output can also drive single ended LO input.

Figure 25 also shows an example of the 8V97003 output driving single-ended LO input of the mixer through an LC balun. The LC balun component values are frequency dependent. These values can be adjusted to optimize the performance. A single-ended LO receiver input also can tap to one side of the differential driver using resistor loading or inductor loading. For single-ended LO input, both sides of the differential driver still need to be loaded with a pull up. The output power level can also be adjusted further through programming.

The loop filter values can be calculated to meet the loop bandwidth requirement (for detailed calculations, see [Loop Filter Calculations](#)).

Figure 25. Schematic Example



Rev	1	2	3
Doc Name	8V97003		
Doc Number	8V97003		
Doc Date	2019.07.20		

## Power Considerations

This section provides information on power dissipation and junction temperature for the 8V97003. Equations and example calculations are also provided.

### 1. Power Dissipation.

The power dissipation for the 8V97003 is the total power minus the power dissipated into the loads. The following is the power dissipation for  $V_{DDX} = 3.3V + 5\% = 3.465V$  at ambient temperature of  $95^{\circ}C$ .

Maximum current at  $95^{\circ}C$ ,  $I_{DDX\_MAX} = 572mA$  (see [Table 8](#))

- Total Power Dissipation:  $Power_{MAX} = V_{DDX\_MAX} * I_{DDX\_MAX} = 3.465V * 572mA = 1982mW$
- Power dissipation in external loads for both outputs:  $Power (output)_{MAX} = 2 * I_{Load2} * 50\Omega = 22.5mW$   
(Load Current with  $Out\_Pwr = 0101$ ,  $I_{Load} = 15mA$ )

**Power Dissipation,  $P_D$**  =  $Power_{MAX} - Power (output)_{MAX} = 1982mW - 22.5mW = 1959.5mW$

### 2. Junction Temperature.

Junction temperature,  $T_j$ , signifies the hottest point on the device and exceeding the specified limit could cause device reliability issues. The maximum recommended junction temperature is  $125^{\circ}C$ .

For devices like this and in systems where most heat escapes from the bottom exposed pad of the package,  $\theta_{JB}$  is the primary thermal resistance of interest.

The equation to calculate  $T_j$  using  $\theta_{JB}$  is:  $T_j = \theta_{JB} * P_D + T_B$ :

$T_j$  = Junction Temperature

$\theta_{JB}$  = Junction-to-Board Thermal Resistance

$P_D$  = Device Power Dissipation (example calculation is in section 1 above)

$T_B$  = Board Temperature

In order to calculate junction temperature, the appropriate junction-to-board thermal resistance  $\theta_{JB}$  must be used. Assuming a 2-ground plane board, the appropriate value of  $\theta_{JB}$  is  $0.76^{\circ}C/W$  (see [Table 6](#)).

Therefore,  $T_j$  for a PCB maintained at  $115^{\circ}C$  with the outputs switching is:

$115^{\circ}C + 1.9595W * 0.76^{\circ}C/W = 116.5^{\circ}C$  which is below the limit of  $125^{\circ}C$ .

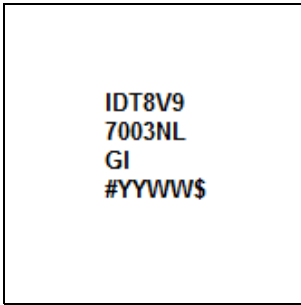
This calculation is only an example.  $T_j$  will obviously vary depending on the number of loaded outputs, supply voltage, air flow, heat transfer method, the type of board (multi-layer) and the actual maintained board temperature.

## Package Outline Drawings

The package outline drawings are appended at the end of this document and are accessible from the link below. The package information is the most current data available.

[www.idt.com/document/psc/48-vfqfpn-package-outline-drawing-70-x70-x-085-mm-body-05mm-pitch-epad-530-x-530-mm-nlg48p3](http://www.idt.com/document/psc/48-vfqfpn-package-outline-drawing-70-x70-x-085-mm-body-05mm-pitch-epad-530-x-530-mm-nlg48p3)

## Marking Diagram



- Lines 1–3 indicate the part number.
- Line 4 indicates the following:
  - “#” denotes stepping.
  - “YY” is the last two digits of the year; “WW” is the work week number when the part was assembled.
  - “\$” denotes the mark code.

## Ordering Information

**Table 59. Ordering Information**

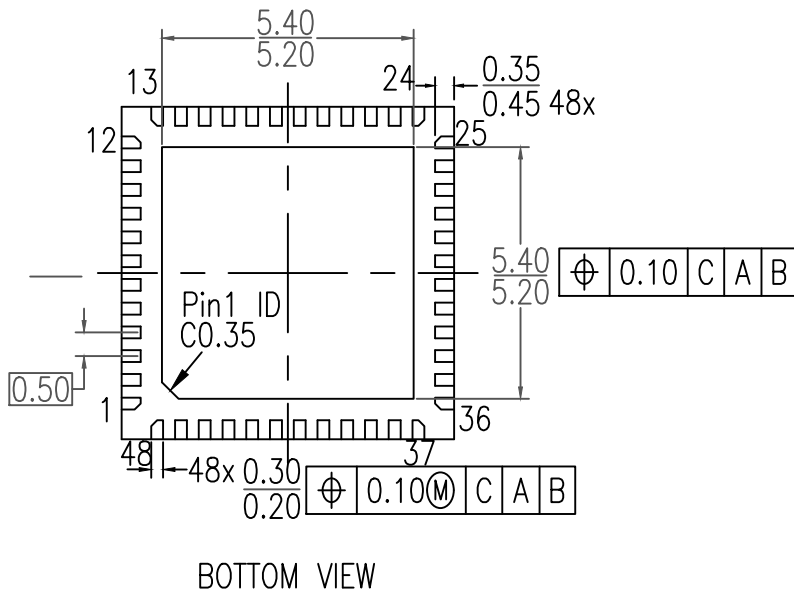
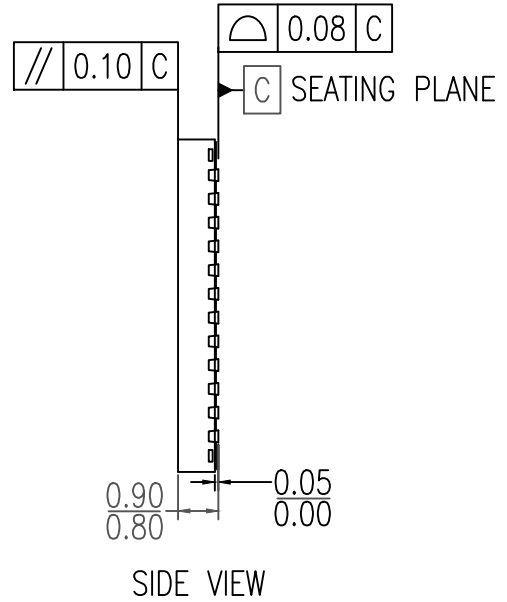
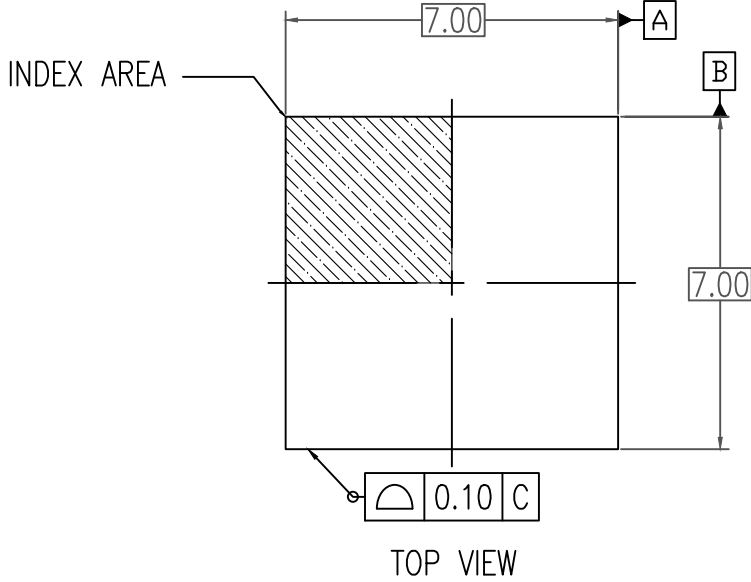
Orderable Part Number	Package	Shipping Packaging	Temperature
8V97003NLGI	7 × 7 mm 48-VFQFPN, Lead-free	Tray	-40°C to +95°C
8V97003NLGI8	7 × 7 mm 48-VFQFPN, Lead-free Pin 1 Orientation: Quadrant 1 (EIA-481-C)	Tape and Reel	-40°C to +95°C
8V97003NLGI/W	7 × 7 mm 48-VFQFPN, Lead-free Pin 1 Orientation: Quadrant 2 (EIA-481-D)	Tape and Reel	-40°C to +95°C

**Table 60. Pin 1 Orientation in Tape and Reel Packaging**

Part Number Suffix	Pin 1 Orientation	Illustration
NLGI8	Quadrant 1 (EIA-481-C)	<p>The illustration shows a carrier tape with three components. Pin 1 is located in the top-left corner of each component. The carrier tape has sprocket holes on the top side. Pink arrows below the tape indicate the 'USER DIRECTION OF FEED' from left to right. Labels include 'Correct PIN 1 ORIENTATION' and 'CARRIER TAPE TOPSIDE (Round Sprocket Holes)'.</p>
NLGI/W	Quadrant 2 (EIA-481-D)	<p>The illustration shows a carrier tape with three components. Pin 1 is located in the top-right corner of each component. The carrier tape has sprocket holes on the top side. Pink arrows below the tape indicate the 'USER DIRECTION OF FEED' from left to right. Labels include 'Correct PIN 1 ORIENTATION' and 'CARRIER TAPE TOPSIDE (Round Sprocket Holes)'.</p>

## Revision History

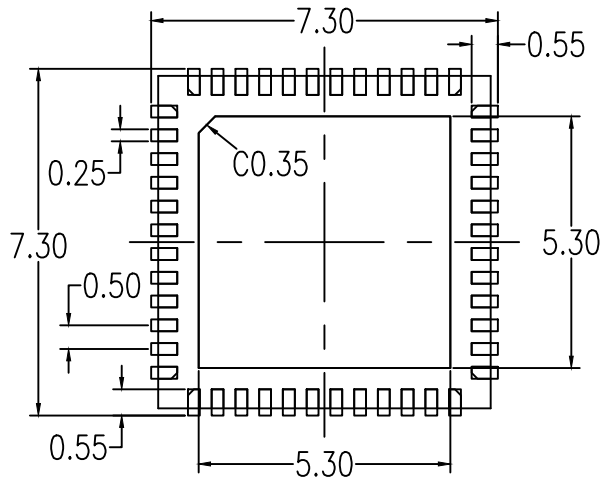
Revision Date	Description of Change
January 20, 2020	<ul style="list-style-type: none"> <li>▪ Corrected a typo for the maximum power setting in the typical current in <a href="#">Table 9</a></li> <li>▪ Added a description for register 7 (Chip option) (see <a href="#">Table 16</a> and <a href="#">Table 22</a>)</li> </ul>
January 8, 2020	<ul style="list-style-type: none"> <li>▪ Corrected the product description on page 1 to indicate output frequency support of “171.875MHz to 18GHz”</li> <li>▪ Updated the <math>f_{RF\_OUT} = 8\text{GHz}</math> test condition for <math>t_{jit}(\emptyset)</math> in <a href="#">Table 12</a></li> <li>▪ Updated <a href="#">Figure 4</a></li> <li>▪ Rebranded the document as Renesas</li> </ul>
December 20, 2019	Initial release.



**NOTES:**

1. ALL DIMENSIONING AND TOLERANCING CONFORM TO ANSI Y14.5M-1982
2. ALL DIMENSIONS ARE IN MILLIMETERS.
3. INDEX AREA (PIN1 IDENTIFIER)





### RECOMMENDED LAND PATTERN DIMENSION

#### NOTES:

1. ALL DIMENSIONS ARE IN MM. ANGLES IN DEGREES.
2. TOP DOWN VIEW. AS VIEWED ON PCB.
3. LAND PATTERN IN BLUE. NSMD PATTERN ASSUMED.
4. LAND PATTERN RECOMMENDATION PER IPC-7351B GENERIC REQUIREMENT FOR SURFACE MOUNT DESIGN AND LAND PATTERN.

Package Revision History		
Date Created	Rev No.	Description
July 9, 2018	Rev 01	New Format, Change QFN to VFQFPN
July 24, 2018	Rev 02	Change P4 to P3

## IMPORTANT NOTICE AND DISCLAIMER

RENESAS ELECTRONICS CORPORATION AND ITS SUBSIDIARIES (“RENESAS”) PROVIDES TECHNICAL SPECIFICATIONS AND RELIABILITY DATA (INCLUDING DATASHEETS), DESIGN RESOURCES (INCLUDING REFERENCE DESIGNS), APPLICATION OR OTHER DESIGN ADVICE, WEB TOOLS, SAFETY INFORMATION, AND OTHER RESOURCES “AS IS” AND WITH ALL FAULTS, AND DISCLAIMS ALL WARRANTIES, EXPRESS OR IMPLIED, INCLUDING, WITHOUT LIMITATION, ANY IMPLIED WARRANTIES OF MERCHANTABILITY, FITNESS FOR A PARTICULAR PURPOSE, OR NON-INFRINGEMENT OF THIRD PARTY INTELLECTUAL PROPERTY RIGHTS.

These resources are intended for developers skilled in the art designing with Renesas products. You are solely responsible for (1) selecting the appropriate products for your application, (2) designing, validating, and testing your application, and (3) ensuring your application meets applicable standards, and any other safety, security, or other requirements. These resources are subject to change without notice. Renesas grants you permission to use these resources only for development of an application that uses Renesas products. Other reproduction or use of these resources is strictly prohibited. No license is granted to any other Renesas intellectual property or to any third party intellectual property. Renesas disclaims responsibility for, and you will fully indemnify Renesas and its representatives against, any claims, damages, costs, losses, or liabilities arising out of your use of these resources. Renesas' products are provided only subject to Renesas' Terms and Conditions of Sale or other applicable terms agreed to in writing. No use of any Renesas resources expands or otherwise alters any applicable warranties or warranty disclaimers for these products.

(Rev.1.0 Mar 2020)

### Corporate Headquarters

TOYOSU FORESIA, 3-2-24 Toyosu,  
Koto-ku, Tokyo 135-0061, Japan  
[www.renesas.com](http://www.renesas.com)

### Contact Information

For further information on a product, technology, the most up-to-date version of a document, or your nearest sales office, please visit:  
[www.renesas.com/contact/](http://www.renesas.com/contact/)

### Trademarks

Renesas and the Renesas logo are trademarks of Renesas Electronics Corporation. All trademarks and registered trademarks are the property of their respective owners.