

1. CONSTRUCTION GaP green visual light emitting diodes packaged with green diffused epoxy.
2. USAGE Power source for display unit.
3. DIMENSIONS See Figure.1
4. ABSOLUTE MAXIMUM RATINGS (Ta=25)

Power Dissipation	P D	75mW
Forward Current	I F	25mA
Peak Forward Current	I F P	60mA (Notes 1)
Reverse Voltage	V R	3V
Operating Temperature	Topr	- 25 ~ + 85
Storage Temperature	Tstg	- 30 ~ + 100
(Notes1 Duty 1/5 Pulse Width 1ms)			

5. ELECTRO - OPTICAL CHARACTERISTICS (Ta=25)

DISCRIPTION	SYMBOL	CONDITION	MIN.	TYP.	MAX.	UNITS
Luminous Intensity	IV	IF=10mA	9.0	25	-	mcd
Forward Voltage	VF	IF=10mA	-	2.1	3.0	V
Reverse Current	IR	VR=3V	-	-	10	μ A
Peak Wave Length	P	IF=10mA	-	563	-	nm
Spectral Line Half Width		IF=10mA	-	40	-	nm

6. LUMINOUS CLASSIFICATION (Ta=25 , IF=10mA)

SYMBOL	LUMINOUS CLASSIFICATION RANGE
“M”	9 . 0 ~ 1 8 mcd
“N”	1 4 ~ 2 8 mcd
“P”	2 2 ~ 4 5 mcd
“Q”	3 6 ~ (7 1) mcd

() : Reference

Due to luminous intensity up, Intensity might shift.

7. PRODUCT WEIGHT Product weight per piece, approx 0.12gm.

【Figure.1 DIMENSIONS(Bulk drawing)】

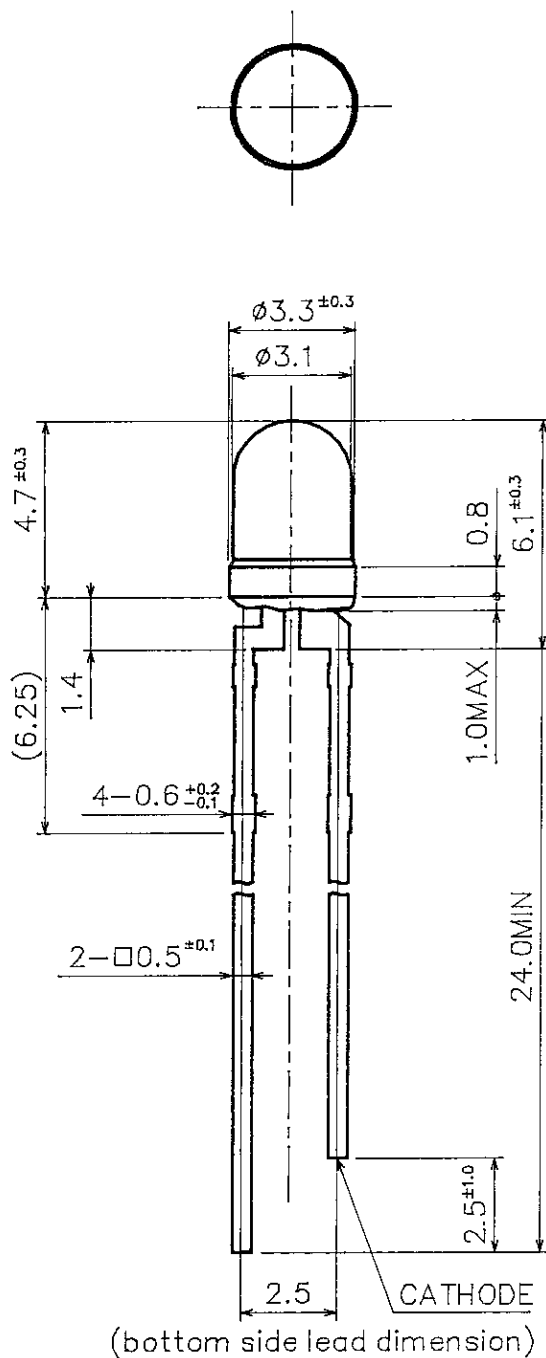

Tolerance : ± 0.2

(Unit : mm)

【STRUCTURE・MATERIAL】

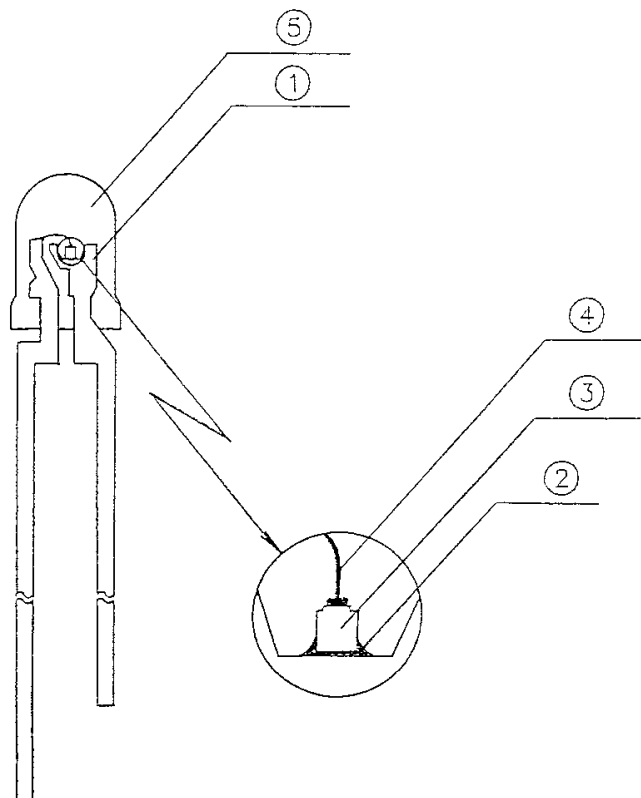

No.	APPELLATION	MATERIAL
1	Lead Frame Lead	Iron Copper + Silver Plating Solder Dip
2	Die Bond	Ag Paste
3	LED Chip	GaAsP on GaP or GaP
4	Bonding Wire	Gold
5	Resin	Epoxy Resin

【PACKAGING REQUIREMENTS】

1. PACKING

- (1) 500pcs to be packaged in a poly-bag.
- (2) 4 poly-bags to be packaged in a paper box.
The paper box shall measure 100(a) × 70(b) × 170(c)mm.

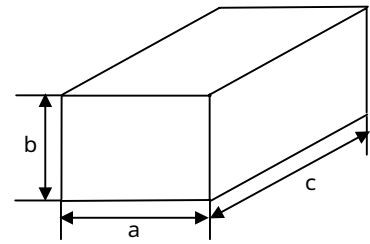

2. MARKING

The following information shall be described on a box label:
ROHM type number, packaging quantity, luminous intensity rank, lot number.

【FORMER LABEL SPECIFICATION】

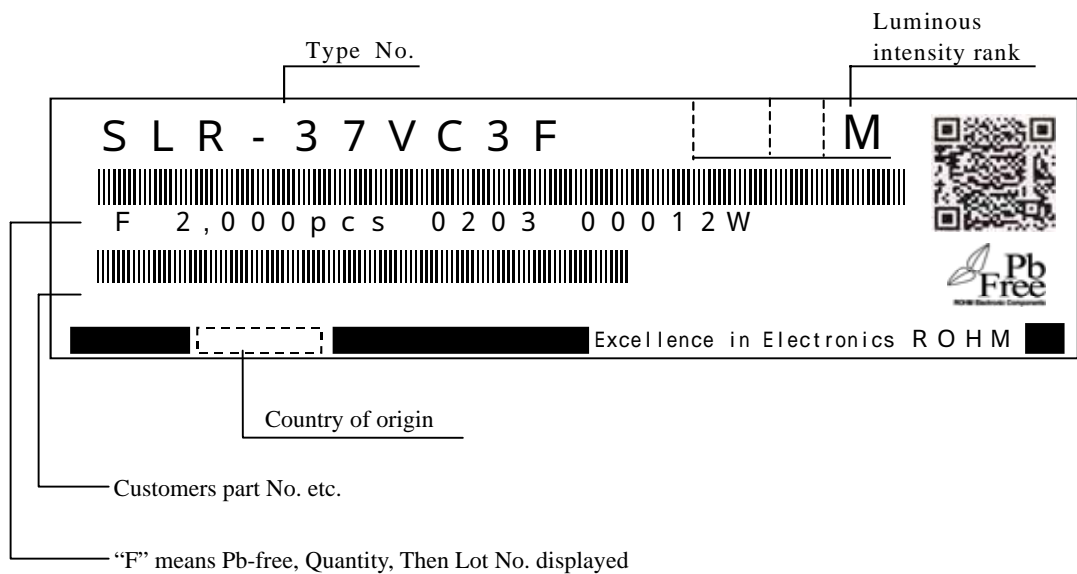

NOTE)  Indicates bar code expressed by code 39

 indicates Pb-free Products.

【EXAMPLE OF LOT NO. MARKING】

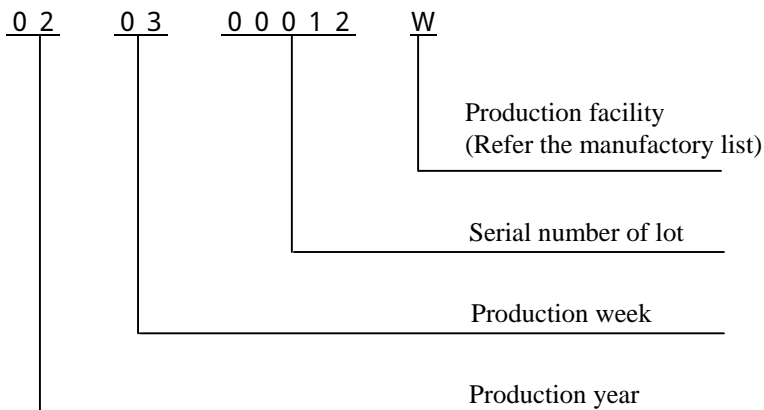

【ATTENTION POINTS IN HANDLING】

Visual light emitting diode does not contain reinforcement materials such as glass fillers. Therefore if sudden thermal and mechanical shock are given, destruction or inferiority of luminous intensity may occur. Please take care of the handling.

FIXATION METHOD

1.ATTENTION POINTS

- 1-1) Please do not give excessive heat over storage temperature to resin.
In case that LED lamp and chip components are assembled on the same pc board, LED lamp would be inserted after a hardening of adhesive material for chip components.
- 1-2) Please avoid stress to resin at high temperature.

2.TERMINATION PROCESSING

- 2-1) In case of termination processing, please fix the termination processing position, and process the reverse side of LED body. Please process before soldering.
If stress is given during processing, It may cause non-lighting failure.

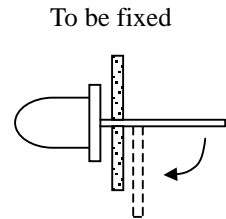

3.ASSEMBLY ON PC BOARD

- 3-1) In case of soldering on PCB, If the operation is done with stress, it may cause non-lighting failure during soldering or using.

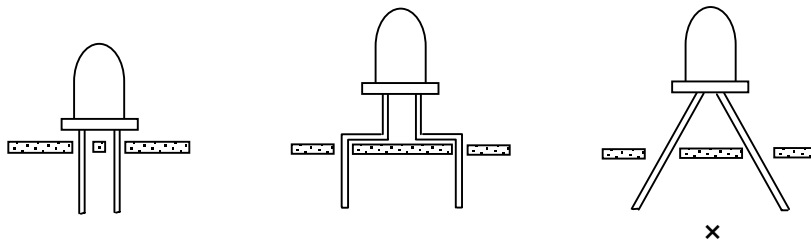

4.SOLDERING (Sn-3Ag-0.5Cu)

- 4-1) Please make soldering rapidly under the following temperature and time conditions.
- 4-2) Please avoid stress to LED lamp during soldering.
- 4-3) Recommendable soldering conditions are as follows :

ARTICLE		SOLDERING TEMP	OPERATION TIME
Soldering Dip	Preheat	Max. 100	Max. 60sec
	Soldering Bath	Max. 265	Max. 5sec
Soldering Iron		Max. 400	Max. 3sec

5.CLEANING

5-1) In case of cleaning, some solvents may cause damage of resin or cause non-lighting failure, so please check the solvent before actual use.

The recommendable cleaning solvent is alcoholic one such as isopropyl alcohol.

RECOMMENDABLE CLEANING CONDITIONS

METHOD	CONDITIONS
Cleaning by solvent	Temperature of solvent : Max. 45 Immersion time : Max. 3min
Cleaning by ultrasonic	Ultrasonic out : Max. 15W/Liter Cleaning time : Max. 3min

ATTENTION ON STORAGING

Storage in dry box is most desirable, but if it is not possible, we recommend following conditions.

Temperature : 5 ~ 30

Humidity : Max. 60%

RECOMMENDABLE ROUND PATTERN

Round pattern depends on the material PCB, density and circuit arrangement.

Our recommendation is as follow :

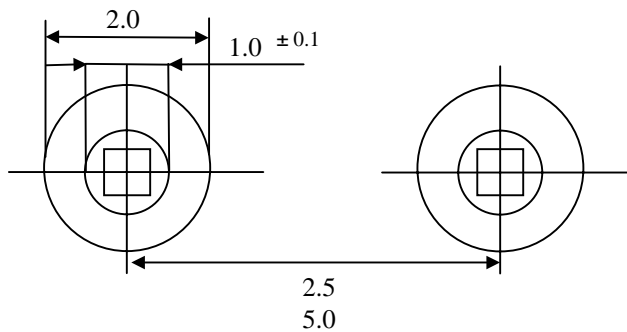

* Unit : mm

* Lead types : 0.5mm

【MANUFACTORY】

FACTORY	SYMBOL
ROHM WAKO CO.,LTD. (KASAOKA CITY, OKAYAMA PREF.JAPAN)	W
ROHM-WAKO ELECTRONICS (MALAYSIA) SDN.BHD. (MALAYSIA)	D
ROHM KOREA CORPORATION (KOREA)	K
ROHM ELECTRONICS COMPONENTS (TIANJIN) CO.,LTD. (TIANJIN. CHAINA)	Y