

**SPECIFICATION**

PRODUCTS: FIXED THICK FILM CHIP RESISTORS

TYPE: MCR03 SERIES

ROHM CO., LTD . RESISTOR DIV .

DESIGN <i>E. Tabuchi</i>	CHECK	APPROVAL <i>Masato Ito</i>	DATE: 6/APR/2005	SPECIFICATION No. : M C R 0 3 - I A
			REV. 1 1 0 E	<b>ROHM CO., LTD.</b>

## &lt; Specifications (Precautions and Prohibitions) &gt;

**Safety Precautions**

- 1) The products are designed and produced for application in ordinary electronic equipment (AV equipment, OA equipment, telecommunication equipment, home appliances, amusement equipment, etc.).  
If the products are to be used in devices requiring extremely high reliability (medical equipment, transport equipment, aircraft/spacecraft, nuclear power controllers, fuel controllers, car equipment including car accessories, safety devices, etc.) and whose malfunction or operational error may endanger human life and sufficient fail-safe measures, please consult with the Company's sales staff in advance.  
If product malfunctions may result in serious damage, including that to human life, sufficient fail-safe measures must be taken, including the following:
  - [a] Installation of protection circuits or other protective devices to improve system safety
  - [b] Installation of redundant circuits in the case of single-circuit failure
- 2) The products are designed for use in a standard environment and not in any special environments.  
Application of the products in a special environment can deteriorate product performance. Accordingly, verification and confirmation of product performance, prior to use, is recommended if used under the following conditions:
  - [a] Use in various types of liquid, including water, oils, chemicals, and organic solvents
  - [b] Use outdoors where the products are exposed to direct sunlight, or in dusty places
  - [c] Use in places where the products are exposed to sea winds or corrosive gases, including Cl<sub>2</sub>, H<sub>2</sub>S, NH<sub>3</sub>, SO<sub>2</sub>, and NO<sub>2</sub>
  - [d] Use in places where the products are exposed to static electricity or electromagnetic waves
  - [e] Use in proximity to heat-producing components, plastic cords, or other flammable items
  - [f] Use involving sealing or coating the products with resin or other coating materials
  - [g] Use involving unclean solder or use of water or water-soluble cleaning agents for cleaning after soldering
  - [h] Use of the products in places subject to dew condensation
- 3) The products are not radiation resistant.
- 4) The Company is not responsible for any problems resulting from use of the products under conditions not recommended herein.
- 5) The Company should be notified of any product safety issues. Moreover, product safety issues should be periodically monitored by the customer.

**Precautions Regarding Application Examples and External Circuits**

- 1) If change is made to the constant of an external circuit, allow a sufficient margin due to variations of the characteristics of the products and external components, including transient characteristics, as well as static characteristics.
- 2) The application examples, their constants, and other types of information contained herein are applicable only when the products are used in accordance with standard methods. Therefore, if mass production is intended, sufficient consideration to external conditions must be made.

< Specifications (Precautions and Prohibitions) >

**Precautions Regarding Foreign Exchange and Foreign Trade Control Law**

- 1) The Company has not determined whether or not the products are considered “a controlled product or labor” as specified in the Foreign Exchange and Foreign Trade Control Law. Accordingly, if exportation of the products, either separately or integrated in another company’s products, is intended, or giving the products to persons who are not residents is planned, additional steps are required, based upon the appropriate regulations.

**Prohibitions Regarding Industrial Property**

- 1) These Specifications contain information related to the Company’s industrial property. Any use of them other than pertaining to the usage of appropriate products is not permitted. Duplication of these Specifications and its disclosure to a third party without the Company’s permission is prohibited.
- 2) Information and data on products, including application examples, contained in these specifications are simply for reference; the Company does not guarantee any industrial property rights, intellectual property rights, or any other rights of a third party regarding this information or data. Accordingly, the Company does not bear any responsibility for:
  - [a] infringement of the intellectual property rights of a third party
  - [b] any problems incurred by the use of the products listed herein.
- 3) The Company prohibits the purchaser of its products to exercise or use the intellectual property rights, industrial property rights, or any other rights that either belong to or are controlled by the Company, other than the right to use, sell, or dispose of the products.

**Precautions on Use of Products**

- 1) Verification and confirmation of performance characteristics of products, after on-board mounting, is advised.
- 2) In particular, if a transient load (a large amount of load applied in a short period of time, such as pulse) is applied, confirmation of performance characteristics after on-board mounting is strongly recommended. Avoid applying power exceeding normal rated power; exceeding the power rating under steady-state loading condition may negatively affect product performance and reliability.
- 3) When a highly active halogenous (chlorine, bromine, etc.) flux is used, the remainder of flux may negatively affect product performance and reliability.
- 4) In principle, the reflow soldering method must be used; if flow soldering method is preferred, please consult with the Company in advance
- 5) Pay attention to the soldering condition in order to avoid problems due to silver absorption into solder.
- 6) Be careful when pick up the products with tweezers.  
There may be a case that the overcoat and /or the body can be chipped.
- 7) Soldering tip shall not touch the product when install product manually.
- 8) Product may be damaged when the impact, such as downfall is given.

**Precautions Regarding Product Storage**

- 1) Product performance and soldered connections may deteriorate if the products are stored in the following places:
  - [a] Where the products are exposed to sea winds or corrosive gases, including Cl<sub>2</sub>, H<sub>2</sub>S, NH<sub>3</sub>, SO<sub>2</sub>, and NO<sub>2</sub>
  - [b] Where the temperature or humidity exceeds those recommended by the Company
- 2) The guaranteed period of solder connections and product performance is within one year from shipment by the Company, provided that the above-mentioned storage conditions have been satisfied.

**Other Matters**

- 1) Please sign these Specifications and return one copy to the Company.  
If a copy is not returned within three months after the issued date specified on the front page of these Specifications, the Company will consider the Specifications accepted.
- 2) If any matter related to these Specifications needs to be clarified, discussions shall be held promptly between the two parties concerned to determine the issue.

### 1.SCOPE

This specification covers the characteristics of "MCR03 series (including jumper type)" based of thick film chip resistors in ROHM Co., Ltd. products.

### 2.CLASSIFICATION

MCR03 TYPE      EZH PACKAGING CODE      J, F \* TOLERANCE      ( ) \* RESISTANCE VALUE (IEC CODE)      \*Jumper is 「J 000」

PACKAGING CODE	PACKAGE	QUANTITY	TOLERANCE	
			F(±1%)	J(±5%)
EZH	180mm(7inch) reel, paper tape (4mm pitch)	5,000pcs/reel	F	J

#### RESISTANCE VALUE

4digits	F
3digits	J

### 3.RATING

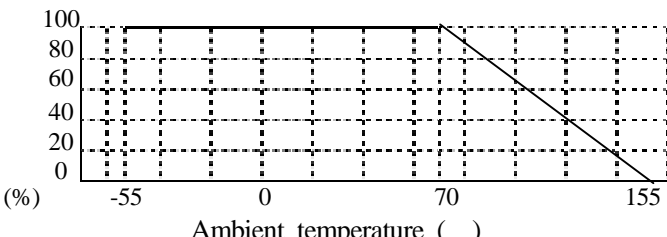
ITEMS	CONDITIONS	SPECIFICATIONS
RATED POWER	For resistors operated at the ambient temperature in excess of 70 , the load shall be derated in accordance with <u>Fig.1</u> 	0.10W(1/10W) at 70
RATED VOLTAGE	Rated voltage is determined from the following. When rated voltage exceeds the limiting element voltage, the limiting element voltage shall be the rated voltage. $E = \sqrt{P \times R}$ E: RATED VOLTAGE (V) P: RATED POWER (W) R: RESISTANCE ( )	LIMITING ELEMENT VOLTAGE   50V
RESISTANCE	See <u>Table.1</u>	
TEMPERATURE		-55 ~ +155

#### Jumper type

RESISTANCE	MAX.50m
RATED CURRENT	1A
TEMPERATURE RANGE	-55 ~ +155

Table.1

TOLERANCE	RESISTANCE RANGE ( )	TEMPERATURE COEFFICIENT (ppm/ )
F(±1%)	10 R < 2.2M (E24,E96)	±200
J(±5%)	1.0 R < 2.2 (E24)	500±350
	2.2 R < 10 (E24)	±500
	10 R < 10M (E24)	±200

#### 4.CHARACTERISTICS

ITEMS	GUARANTEED VALUE		TEST CONDITIONS (JIS C 5201-1)
	RESISTOR TYPE	JUMPER TYPE	
4.1 RESISTANCE	F:±1% J:±5%	MAX. 5 0 m	JIS C 5201-1 4.5
4.2 VARIATION OF RESISTANCE WITH TEMPERATURE	See <a href="#">Table.1</a>		JIS C 5201-1 4.8 Measurement : -55/+25/+125 Mounting condition: See <a href="#">Fig.3</a>
4.3 OVERLOAD	±(2.0% + 0.1 )	MAX. 5 0 m	JIS C 5201-1 4.13 Rated voltage(current) × 2.5 , 2s Limiting Element Voltage × 2 : 100V Mounting condition: See <a href="#">Fig.3</a>
4.4 SOLDERABILITY	A new uniform coating of minimum of 95% of the surface being immersed and no soldering damage.		JIS C 5201-1 4.17 Rosin• Ethanol(25%WT) Soldering condition : 235 ± 5 Duration of immersion : 2.0 ± 0.5s.
4.5 RESISTANCE TO SOLDERING HEAT	±(1.0% + 0.05 ) No remarkable abnormality on the appearance.	MAX. 5 0 m	JIS C 5201-1 4.18 Soldering condition : 260 ± 5 Duration of immersion : 10 ± 1s.
4.6 RAPID CHANGE OF TEMPERATURE	±(1.0% + 0.05 )	MAX. 5 0 m	JIS C 5201-1 4.19 Test temp. : -55 ~ +125 5cyc Mounting condition: See <a href="#">Fig.3</a>
4.7 DAMP HEAT, STEADY STATE	±(3.0% + 0.1 )	MAX. 1 0 0 m	JIS C 5201-1 4.24 40 , 93%RH Test time : 1,000h ~ 1,048h Mounting condition: See <a href="#">Fig.3</a>
4.8 ENDURANCE AT 70	±(3.0% + 0.1 )	MAX. 1 0 0 m	JIS C 5201-1 4.25.1 Rated voltage(current),70 1.5h:ON - 0.5h:OFF Test time : 1,000h ~ 1,048h Mounting condition: See <a href="#">Fig.3</a>
4.9 ENDURANCE	±(3.0% + 0.1 )	MAX. 1 0 0 m	JIS C 5201 -1 4.25.3 155 Test time : 1,000h ~ 1,048h Mounting condition: See <a href="#">Fig.3</a>
4.10 RESISTANCE TO SOLVENT	±(1.0% + 0.05 )	MAX. 5 0 m	JIS C 5201-1 4.29 23 ± 5 , Immersion cleaning, 5 ± 0.5min Solvent: 2-propanol
4.11 BEND STRENGTH OF THE END FACE PLATING	±(1.0% + 0.05 ) Without mechanical damage such as breaks.	MAX. 5 0 m	JIS C 5201-1 4.33 Mounting condition: See <a href="#">Fig.4</a>

\* In the items on characteristics, the expression " ±(1.0% + 0.05 )" is used in the column for standard values.  
 However, this is because of dramatic increase in the fluctuation ratio that can be take place in the low resistance value range and is not meant to supplement the measuring accuracy of the measuring instruments.  
 Accordingly, there is a need to increase the design tolerance in the low resistance value range.

5 . DIMENSIONS & CONSTRUCTION

Fig.2

(UNIT: mm)

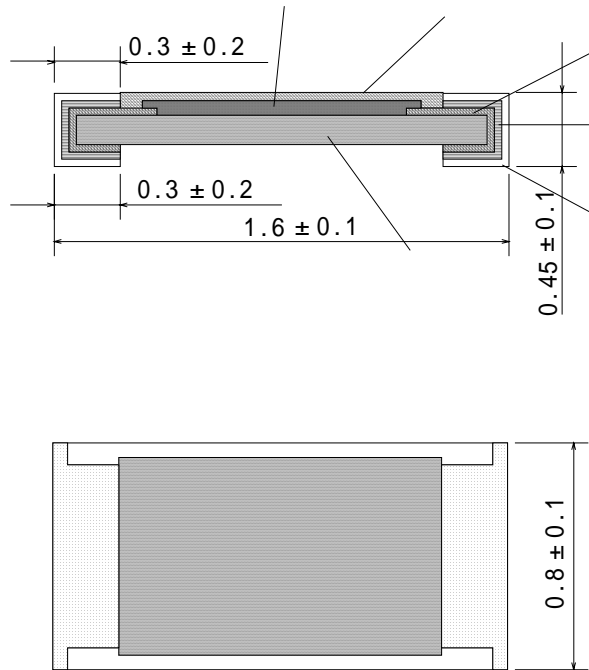

MATERIAL	
	Resistive element
	Silver thick film electrode
	Nickel electrode
	Sn electrode
	Alumina substrate
	Over coating

## 6 . MARKINGS

### 6 . 1 Markings on chip resistor

The description of markings on the chip resistor are as shown below.

Blue glass over coat is used for marking on the jumper type.

\* On jumper types, there may be some products with one part of the markings missing.

Marking method : There are three digits used for the calculation number according to IEC code and " R " is used for the decimal point.

Example : 100k =104    2.2 =2R2

Marking direction : Standard, Resistor surface marking.

Marking colors : Yellowish white marking or other appropriate marking

### 6 . 2 Marking on the packaging container

The following items will be displayed on the smallest unit of the container used for Packaging.



Type + Packaging code + Tolerance + Resistance value

Bar code of type code + Resistance value

Special code + Quantity + Lot No.

(There may be label with and without special code.)

Bar code of Quantity + Lot No.

Part No. + Order No.

(To be executed on necessity)

QR code (There may be labels with and without QR code.)

## 7 . APPEARANCE QUALITY

An appearance inspection of the surface should reveal no obvious abnormalities.

There should be no obvious abnormalities such as bubbles, pin holes or cracks on the overcoat or outer termination.

There should be no obvious electrode material or other foreign matter on the overcoat.

There should be no obvious electrode material or other foreign matter on back surface of the substrate and on side surface of the longitudinal axis.

## 8 . MASS

The mass of the chip resistor is 2.0mg ± 0.5mg.

## 9 . Deciphering the manufacturing date from the Lot No.

An example of the Lot No. is shown below. Read the manufacturing date and take first-in first-out method.

Example :      00        05        xxxxx     x  

Manufacturing year : Last two digits of the western calendar year. (2000)

Week of manufacture : Shows week 01 to 53 in a year. (05:1/23 to 1/29)

Shows line number, serial number or manufacturing plant Code.

## 1 0 . RECOMMENDABLE CONDITION OF SOLDERING

### 1 0 . 1 REFLOW SOLDERING

#### (1) Reflow soldering with lead solder.

Condition of soldering : Preheat 150 less than 1min.  
Maximum temperature :  $240 \pm 5$  less than 6s.  
Time : Maximum of twice.

#### (2) Reflow soldering with lead free solder.

Condition of soldering : Preheat 150 less than 1min.  
Maximum temperature :  $260 \pm 5$  less than 10s.  
Time : Maximum of twice.

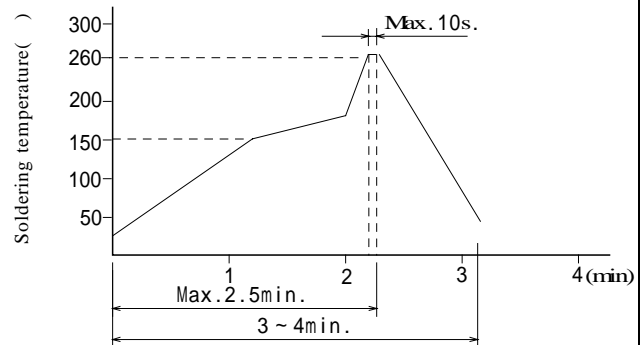
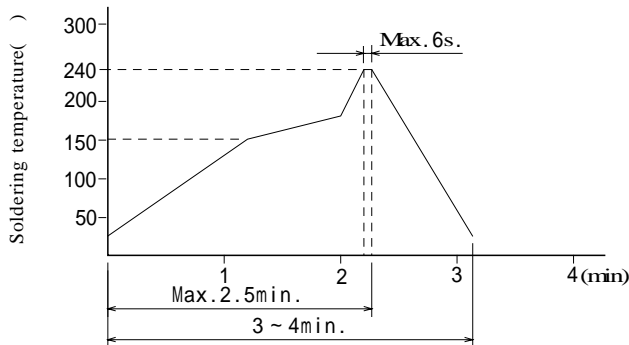

### 1 0 . 2 Reworking of soldering

Reworking of soldering shall be limited to one time.  
Temperature of soldering tip : 350 or less.  
Working time : Not longer than 3s.  
Soldering iron : 20W or less.

## 1 1 . OTHERS

### 1 1 . 1 In regard to the Export Trade Control Decree.

Resistor That Rohm Co., Ltd . sells is not an object of controlled goods in Annex 1(Item 1 ~ 15) of Export Trade Control Order.  
But it is an object of controlled goods in Annex 1(Item 16) of Export Trade Control Order. In case of export, please confirm if it applies to "objective" criteria or an "informed"(by MITT clause) on the basis of "catch-all" controls for Non-Proliferation of Weapons of Mass Destruction.

### 1 1 . 2 On use of ozone layer destroying substances

No ozone layer destroying substances are used in our resistors.

### 1 1 . 3 On use of fluorocarbons

No specific fluorocarbons or alternative fluorocarbons are used in the manufacture of our resistors.

### 1 1 . 4 Regarding specific bromine type fire resistant materials

None of the following specific bromine type materials are used in our resistors.

P B B 0 s  
P B B s

### 1 1 . 5 Requests prior to changes

In the manufacture and utilization of the chip resistors there are conditions that develop which require materials or processes to be changed. In such cases, request will be made prior to change to obtain approval.

### 1 1 . 6 Manufacturing flow chart and basic design quality

As requested specially, the flow chart for the manufacturing processes of the chip resistor and the basic quality will be submitted separately.



Fig.3 : TEST BOARD A

(UNIT: mm)

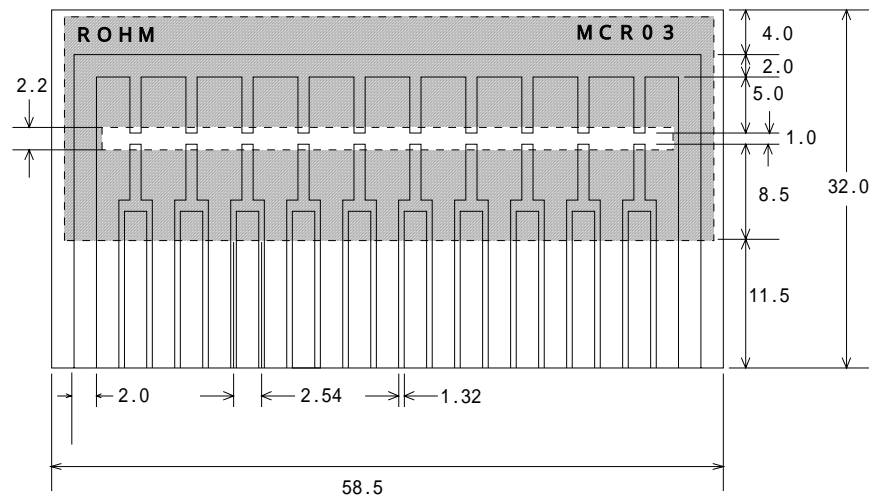

- NOTE) \*1 The shaded area shows the solder resist treatment.  
 \*2 The terminals used for connectors are plated with rhodium.  
 \*3 All surface, except terminals used for connectors, receive pre-flux treatment.

Fig.4 : TEST BOARD B

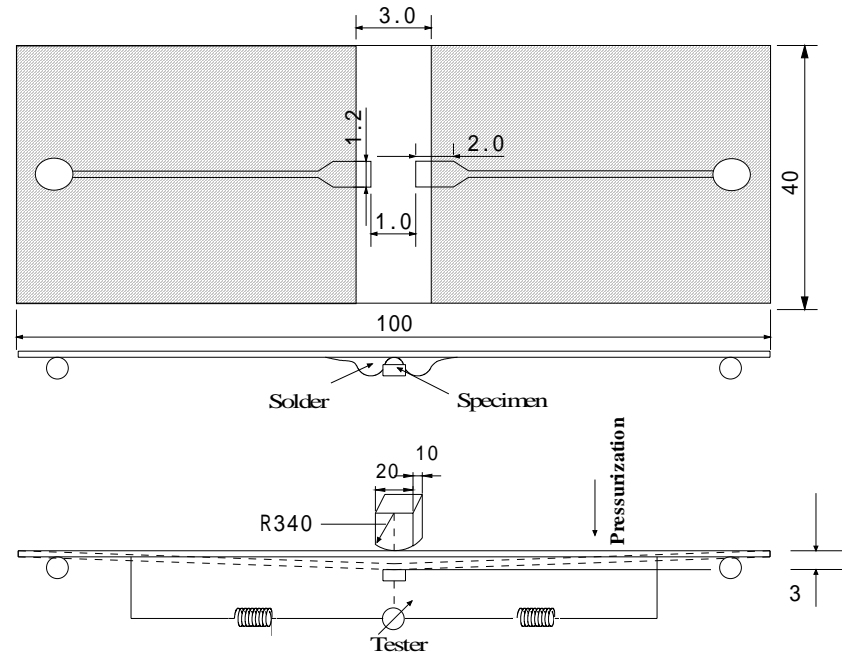

- NOTE) \*1 The shaded area shows the solder resist treatment.  
 \*2 All surface, except terminals used for connectors, receive pre-flux treatment.  
 \*3 During the test, the distance among support points shall be 90mm and the center of the chip resistor and the center between support points should be aligned to within  $\pm 2$ mm.

Laminate material: Glass fabric base epoxies.  
 Compatible with JIS C 6484  
 Thickness of board : 1.6mmt

Copper material: Copper purity is 99.5% or more.  
 Compatible with JIS C 6484  
 Copper foil thickness : 35  $\mu$  m

### 1. SCOPE

This specification covers the tape package requirements for chip resistor MCR03, to be used on automatic placement systems.

### 2. PACKAGING CODE

<u>MCR03</u>	<u>EZH</u>	<u>J, F</u>	<u>( )</u>
TYPE	PACKAGING CODE	RESISTANCE TOLERANCE	RESISTANCE VALUE (IEC CODE)

### 3. TAPE DIMENSION (UNIT: mm)

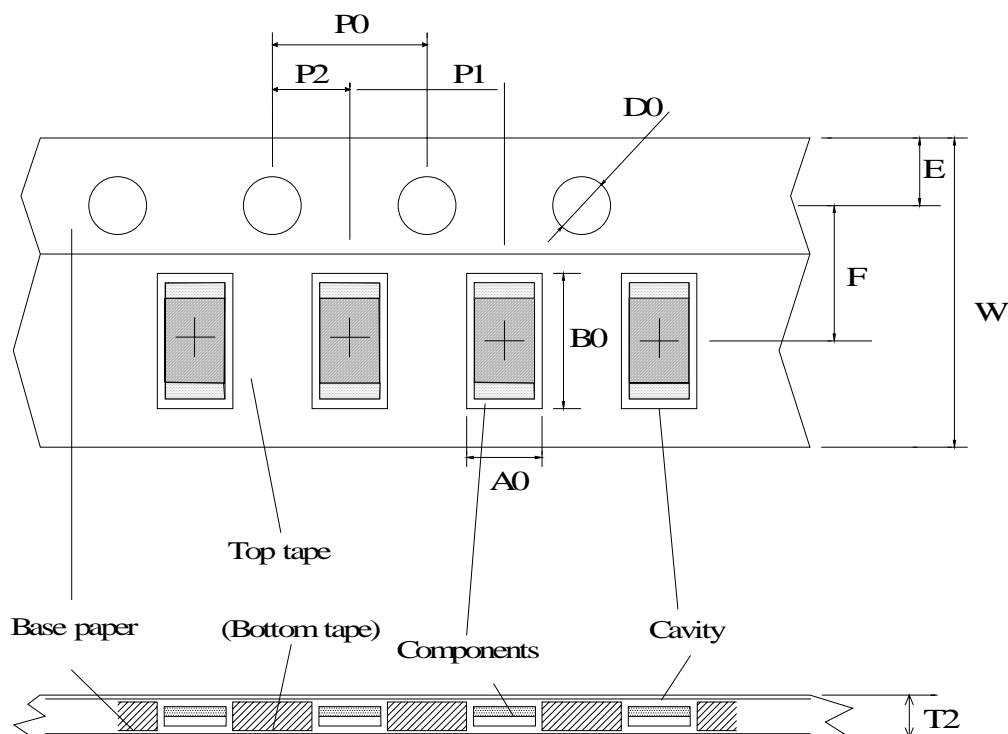

W	F	E	A0	B0
8.0 ± 0.3	3.5 ± 0.05	1.75 ± 0.1	1.1 ± 0.1	1.9 ± 0.1
D0	P0	P1	P2	T2
<sup>+0.1</sup> 1.5 0	4.0 ± 0.1	4.0 ± 0.1	2.0 ± 0.05	MAX.1.1

#### 4. MECHANICAL CHARACTERISTICS

##### 4.1 COVER TAPE PEELING STRENGTH

: 0.1N PEELING STRENGTH 0.6N

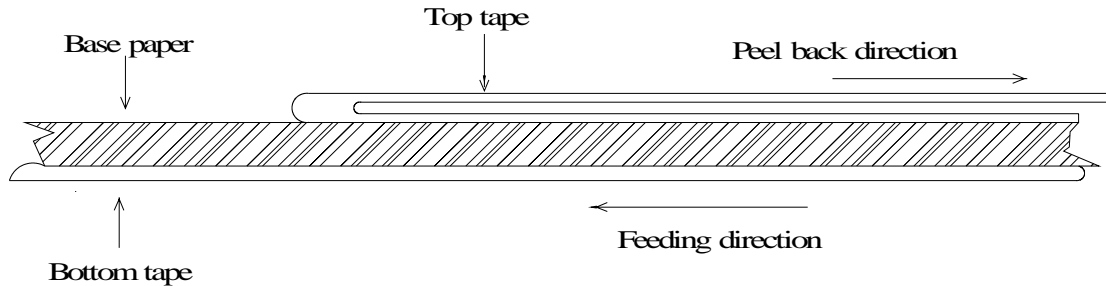

4.2 Base tape should not adhere to top tape when top tape is peeled back, and peel back direction is as follows.

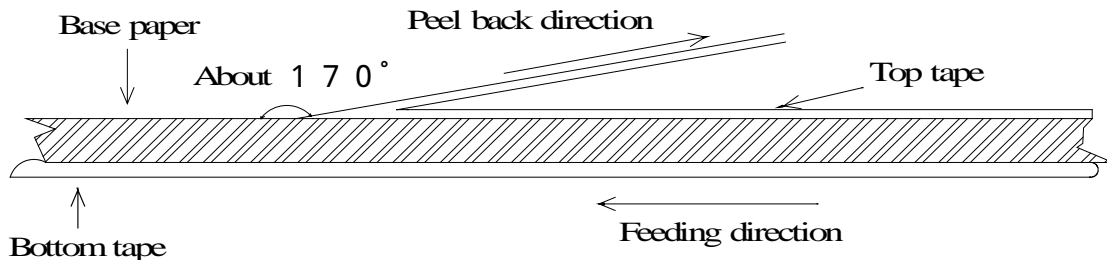

##### 4.3 DURABILITY OF COVER TAPE (TOP TAPE)

Top tape shall not be off the base paper after 120hrs at the atmosphere of  $60 \pm 3$  ,90 ~ 95%R.H.

#### 5. TAPE PACKAGING

5.1 Components are set in tape cavities with the same side (resistive paste upside).

5.2 The accumulated pitch tolerance shall be within  $\pm 0.2\text{mm}$  at 10 pitches.

5.3 Tape bent resistance

No damage on the tape and the cavity when tape is bent with the radius of 15mm.

5.4 Components in tape cavity shall not adhere to bottom / cover tape.

5.5 Components shall not be blocked by tape fragments or foreign materials when they are taken out from cavities.

5.6 The top tape shall not cover up the sprocket holes of tape.

5.7 The number of missing components shall not exceed 0.1% of the total number of components (marked number) or one whichever is the larger, and no consecutive missing exceeding two is allowed.

## 6. TAPE REEL

6.1 Tape feeding direction shall be shown in the picture drawn below.

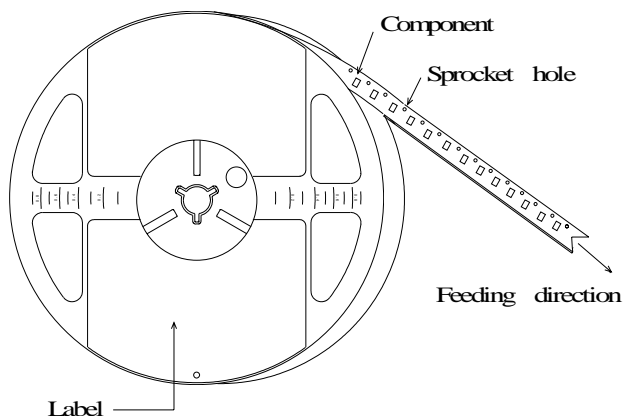

### 6.2 Leader tape

Leader tape is given a portion of only cover tape and of blank cavities. (no resistor.)

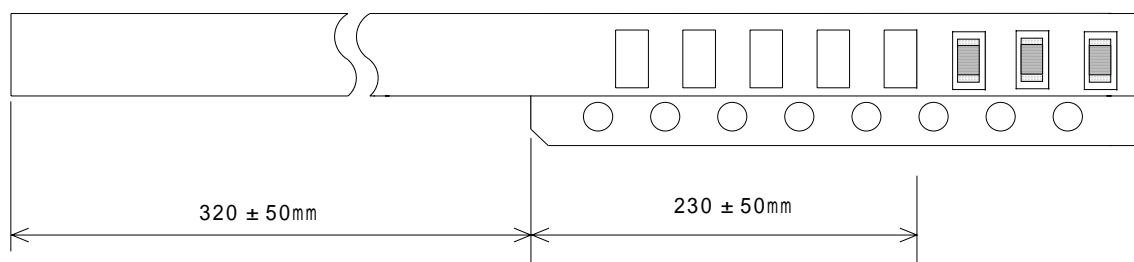

(Note) The leader portion of cover tape will not stick to embossed tape. (about 5 ~ 10mm)

### 6.3 Tail tape(trail tape)

Trail tape is given a portion of blank cavities (no resistor).

And the trail tape should not be fixed by adhesive to real and must be the one which can be pulled out easily from the reel.

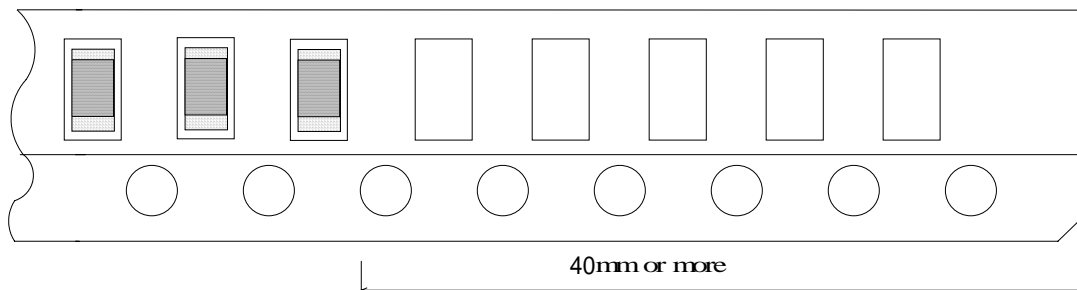

7. REEL DIMENSIONS (UNIT: mm)

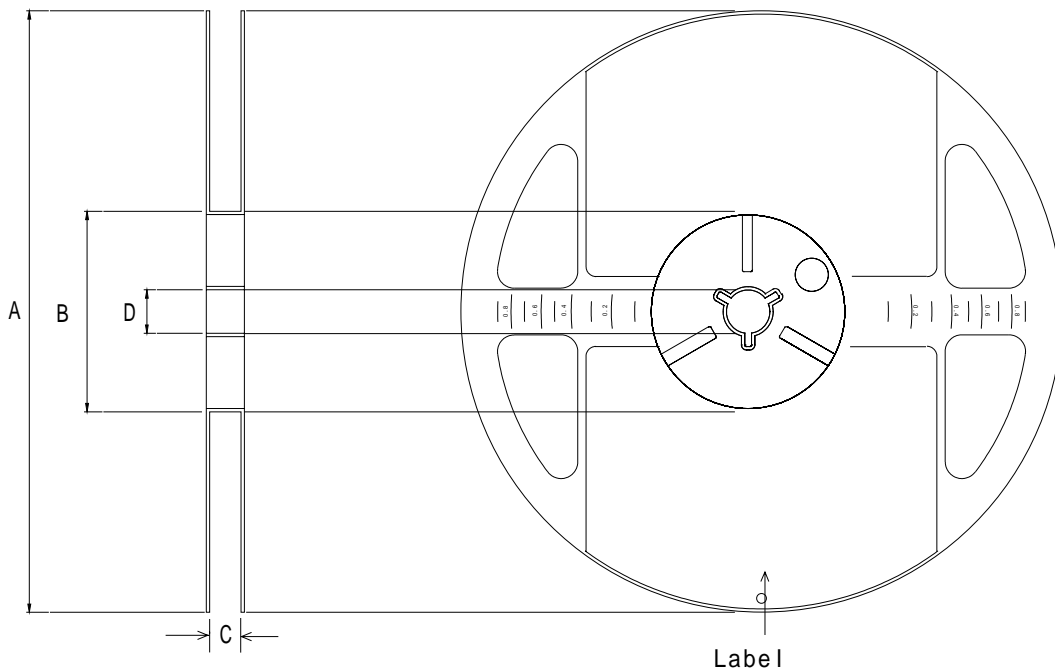

ACCORDING TO EIAJ ET-7200B

A	B	C	D
0	+1	+1.0	
180	60	9	13 ± 0.2
-1.5	0	0	

MATERIAL

REEL: POLYSTYRENE

PACKING

5,000pcs / Reel