

# DC / DC converter for LCDs

## BP5302A / BP5302XA

The BP5302A and BP5302XA are DC / DC converters for supplying power to liquid crystal display (LCD) panels. The modules supply a negative voltage from a positive power supply. They are available in a single in-line package as an upright (BP5302A) or L-shaped lead (BP5302XA) type.

### ●Applications

LCD panels in personal computers and word processors

### ●Features

- 1) Wide input voltage range.(+5V to +14V)
- 2) High accurate output voltage. (  $-24\pm 0.75V$ )
- 3) High conversion efficiency. (Typ. 80%)
- 4) Built-in protection circuit.
- 5) Built-in ON/OFF switch.
- 6) Compact and light.
- 7) Available as an upright or L-shaped lead type.

### ●Absolute maximum ratings (Ta=25°C)

Parameter	Symbol	Limits	Unit
Input voltage	V <sub>IN</sub>	15	V
Operating temperature range	T <sub>opr</sub>	0~60	°C
Storage temperature range	T <sub>stg</sub>	-30~85	°C

## Power Module

## ●Electrical characteristics

(Unless otherwise noted: Ta=25°C and R1 and R2 resistors in the measurement circuit of Fig.1 are disconnected)

Parameter	Symbol	Min.	Typ.	Max.	Unit	Conditions
Input voltage	V <sub>IN</sub>	5	-	14	V	
Output current	I <sub>OUT</sub>	-	-	30	mA	
Output voltage	V <sub>OUT</sub>	-23.25	-24.00	-24.75	V	V <sub>IN</sub> =12V, I <sub>OUT</sub> =20mA
Line regulation	ΔV1	-	-	0.75	V	V <sub>IN</sub> =5~14V, I <sub>OUT</sub> =20mA
Load regulation	ΔV2	-	-	0.5	V	V <sub>IN</sub> =12V, I <sub>OUT</sub> =0~20mA
Ripple noise voltage	v1	-	-	200	mV <sub>P-P</sub>	V <sub>IN</sub> =12V, I <sub>OUT</sub> =20mA *
Efficiency	η	70	80	-	%	V <sub>IN</sub> =12V, I <sub>OUT</sub> =20mA
ON / OFF CTL voltage when ON	V <sub>CTL</sub>	1.5	-	6.0	V	V <sub>IN</sub> =5~14V
ON / OFF CTL voltage when OFF	V <sub>CTL</sub>	-	-	0.5	V	V <sub>IN</sub> =5~14V
		(Alternatively, when OPEN)				
ON / OFF CTL current	I <sub>CTL</sub>	-	-	150	μA	V <sub>IN</sub> =5~14V, V <sub>CTL</sub> =5V
Current consumption when OFF	I <sub>OFF</sub>	-	-	10	μA	V <sub>IN</sub> =5~14V, V <sub>CTL</sub> =0V
R1 resistance	R1	50	-	∞	kΩ	V <sub>IN</sub> =5~14V, V <sub>CTL</sub> =5V
R2 resistance	R2	20	-	∞	kΩ	V <sub>IN</sub> =5~14V, V <sub>CTL</sub> =5V

\* Measured with a band width of 20MHz.

## ●Pin descriptions

Pin No.	Pin name	Function
1	C <sub>o</sub>	Output smoothing capacitor connection pin; connect a low-impedance capacitor with a recommended capacitance of 47μF between this pin and GND
2	V <sub>OUT</sub>	Output pin
3	V <sub>ref</sub>	Output voltage adjustment pin for contrast; output voltage is adjusted by connecting a resistor between pins 2 and 3 or pins 3 and 4
4, 7	GND	Ground pin
8	V <sub>CTL</sub>	Output ON / OFF control pin; output starts when the pin is HIGH level, and stops when the pin is LOW or OPEN
9	V <sub>IN</sub>	Input pin; connect a low-impedance capacitor with a recommended capacitance of 100μF between this pin and GND

## Power Module

## ● Measurement circuit and Application example

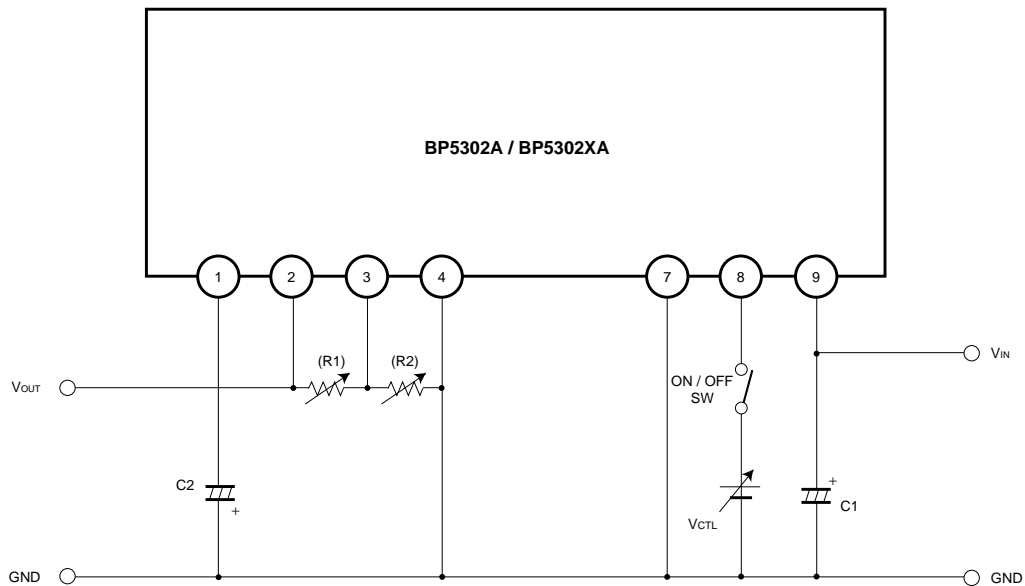

Fig.1

C1 : 100 $\mu$ F / 16V (Low impedance)

C2 : 47 $\mu$ F / 35V (Low impedance)

R1, R2 : Resistors for adjusting output voltage (Disconnected during test measurement)

## ● Operation notes

(1) Place I/O external capacitors as near as possible to the connection pins. In particular, make sure to minimize the impedance between the input-side capacitor (C1) and pin 9.

(Reference value: A length less than 50mm is recommended for a copper foil of 1.0mm wide and 35 $\mu$ F thick.)

(2) Avoid frequent switching using the ON/OFF CTL pin (5 times per second at the maximum).

(3) R1 and R2 resistors, which are used for changing the output voltage, are usually not required.

Power Module

● Electrical characteristic curves

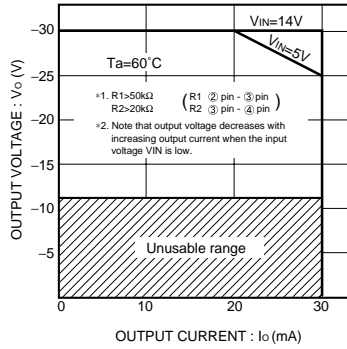

Fig.2 Derating curve

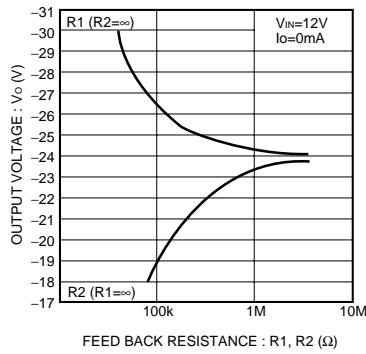

Fig.3 Output voltage vs. Feedback resistance (R1, R2)

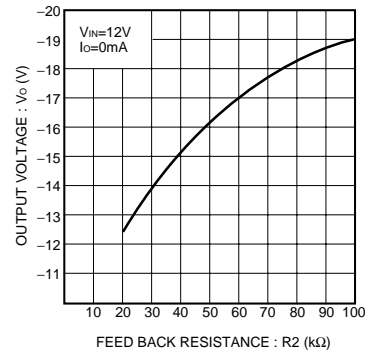

Fig.4 Output voltage vs. Feedback resistance (R2 < 100kΩ)

● External dimensions (Units : mm)

