



Specification	Products	Type
	SURFACE MOUNT LEDS (Side Light Type)	SML-110MT

1. TYPE NAME SML-110MT
2. CONSTRUCTION GaP green surface mount LEDs with reflector packaged with transparent and colorless epoxy.
3. USAGE Source of light for display unit.
4. DIMENSIONS See Figure 1
5. ABSOLUTE MAXIMUM RATINGS (Ta=25°C)

2/6

Power Dissipation	P_D	70 mW
Forward Current	I_F	25 mA
Peak Forward Current	I_{FP}	60 mA (notes 1)
Reverse Voltage	V_R	4 V
Operating Temperature	T_{opr}	-30°C ~ +85°C
Storage Temperature	T_{stg}	-40°C ~ +85°C

(notes 1 Duty 1/5 Pulse Width 1ms)

6. ELECTRO-OPTICAL CHARACTERISTICS (Ta=25°C)

DESCRIPTION	SYMBOL	CONDITION	MIN	TYP	MAX	UNITS
Luminous Intensity	I_V	$I_F = 20mA$	5.6	16	-	mc d
Forward Voltage	V_F	$I_F = 20mA$	-	2.2	2.8	V
Reverse Current	I_R	$V_R = 4V$	-	-	100	μA
Peak Wave Length	λ_p	$I_F = 20mA$	-	570	-	nm
Spectral Line Half Width	$\Delta \lambda$	$I_F = 20mA$	-	40	-	nm
Input/Output Frequency	—	—	-	34.2	-	MHz

7. LUMINOUS CLASSIFICATION (Ta=25°C, IF=20mA)

SYMBOL	LUMINOUS CLASSIFICATION RANG
"L"	5.6 ~ 11 mc d
"M"	8.0 ~ 18 mc d
"N"	14 ~ 28 mc d
"P"	22 ~ 45 mc d

ROHM CO., LTD.

Design <i>T. Yamaguchi</i>	Approval <i>[Signature]</i>	Specification No.	Date Jun./22/95
-------------------------------	--------------------------------	-------------------	--------------------



Specification

Products SURFACE MOUNT LEDS (Side Light Type)

Type

SML-110

Figure.1

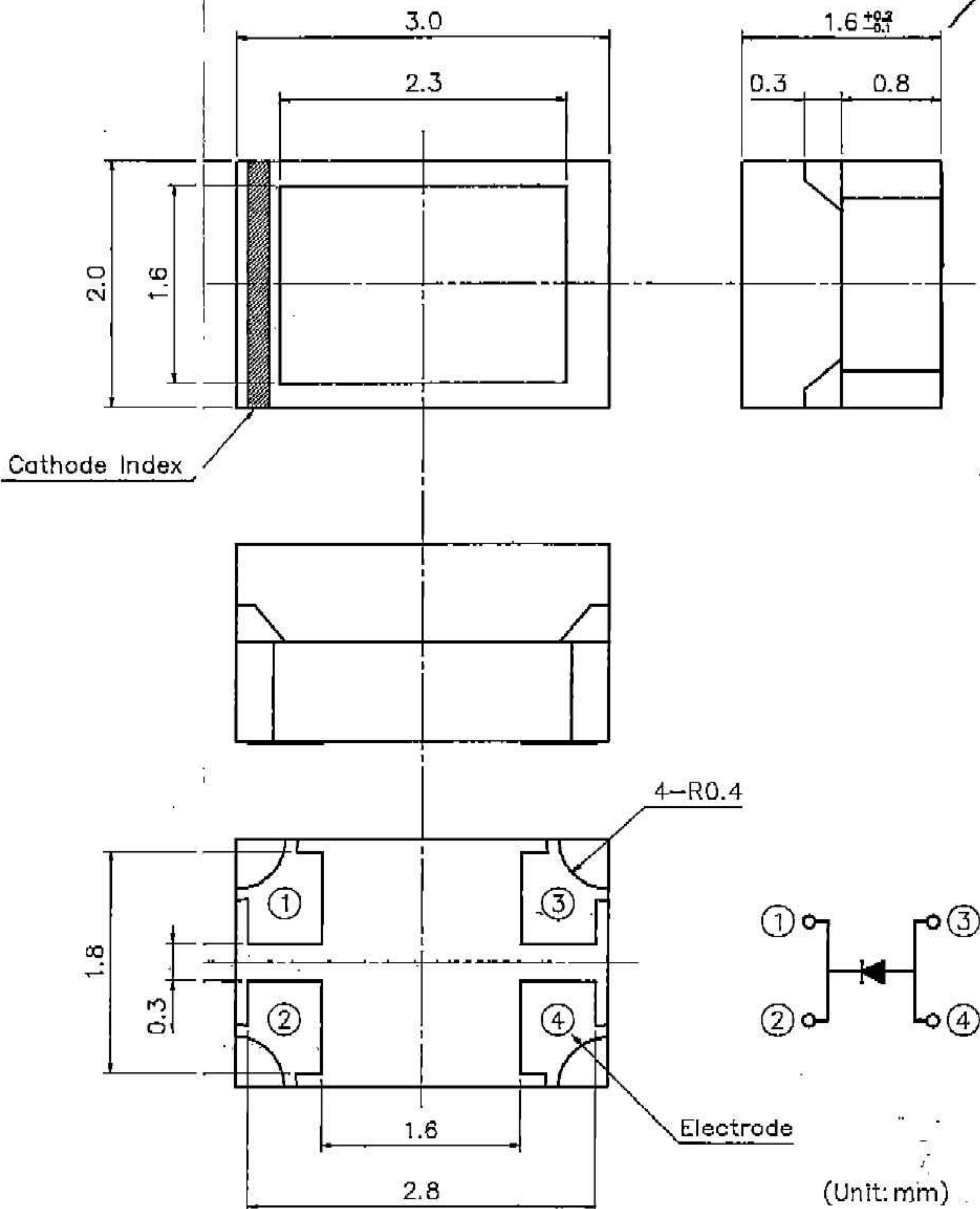

(note) Tolerance is within ± 0.2 mm unless otherwise specified.

ROHM

Specification	Products	Type
	SURFACE MOUNT LEDS(Side Light Type)	T 8 6

4/6

SML-110 reel specification

Direction of luminous part →

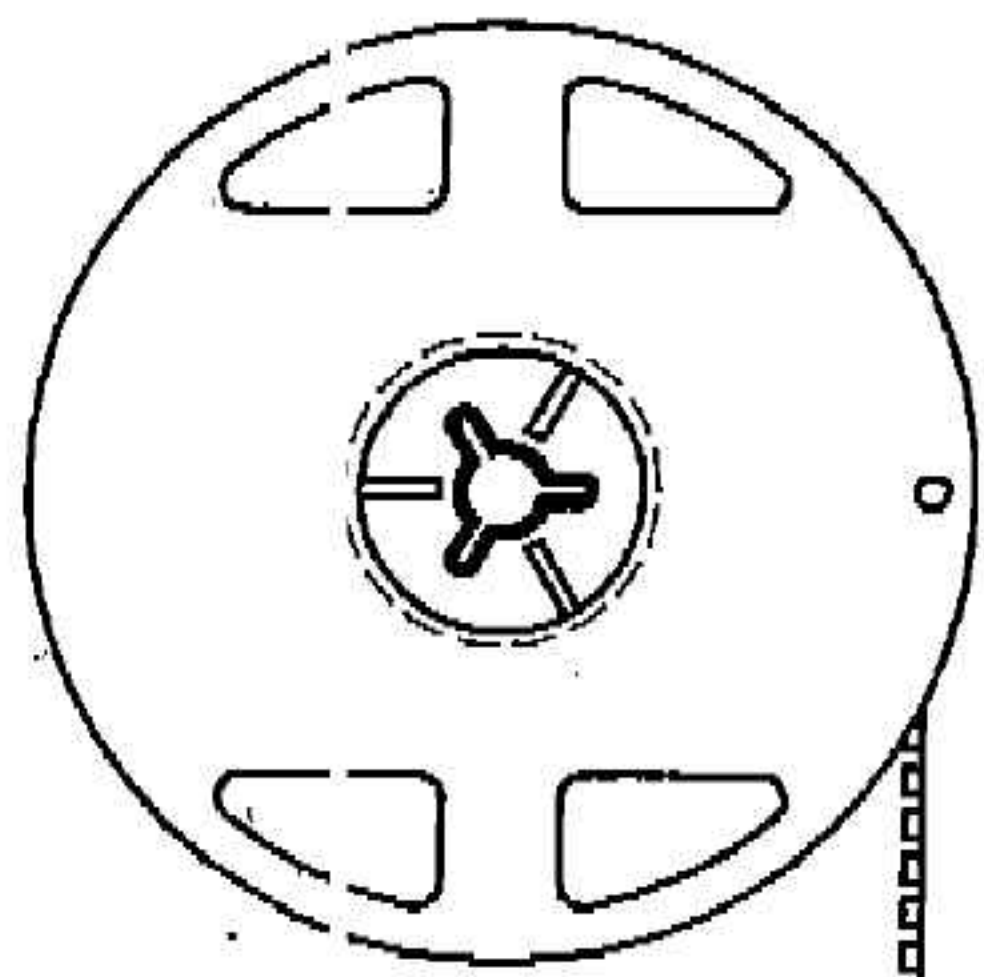
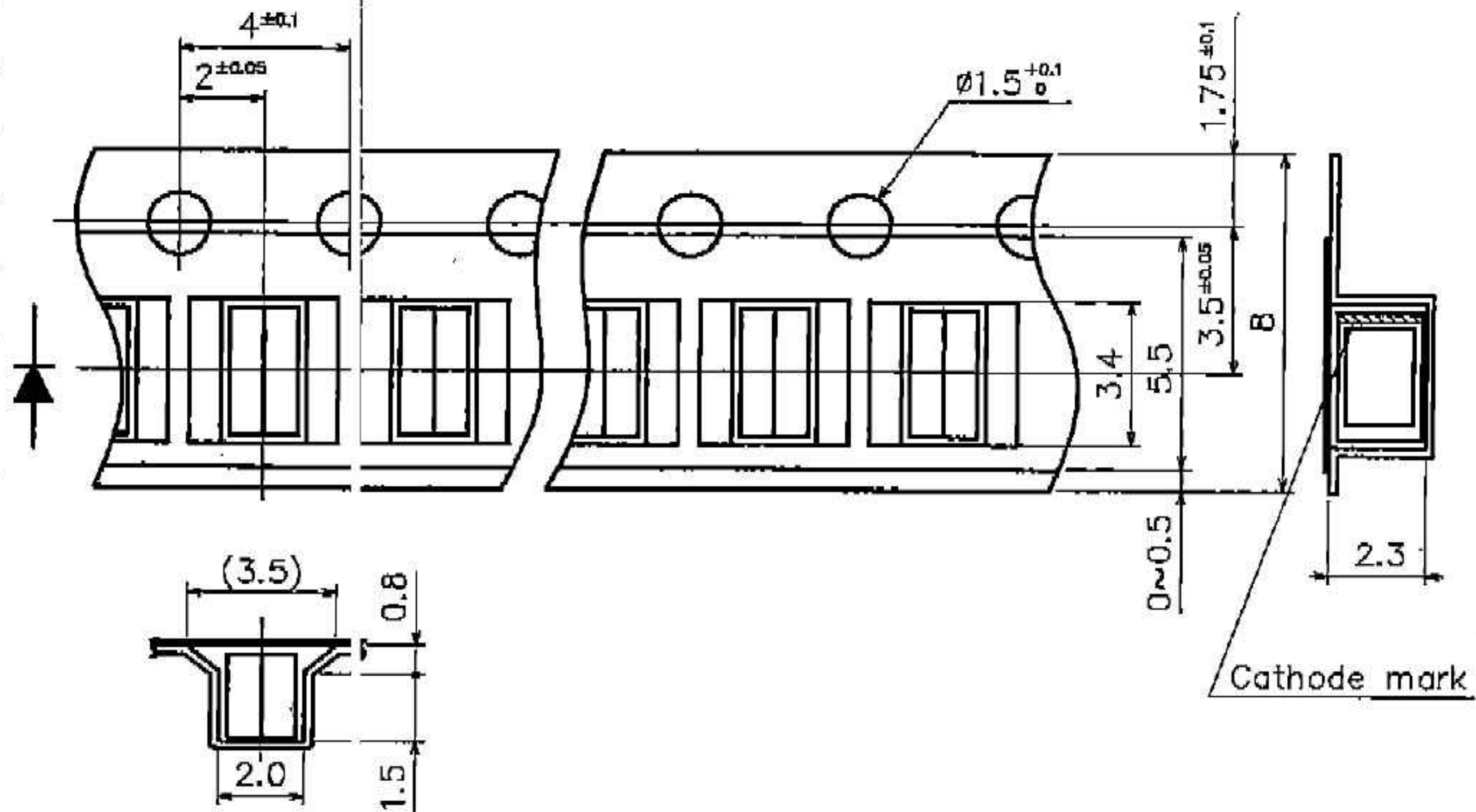

Packing quantity
2,000pcs/Reel

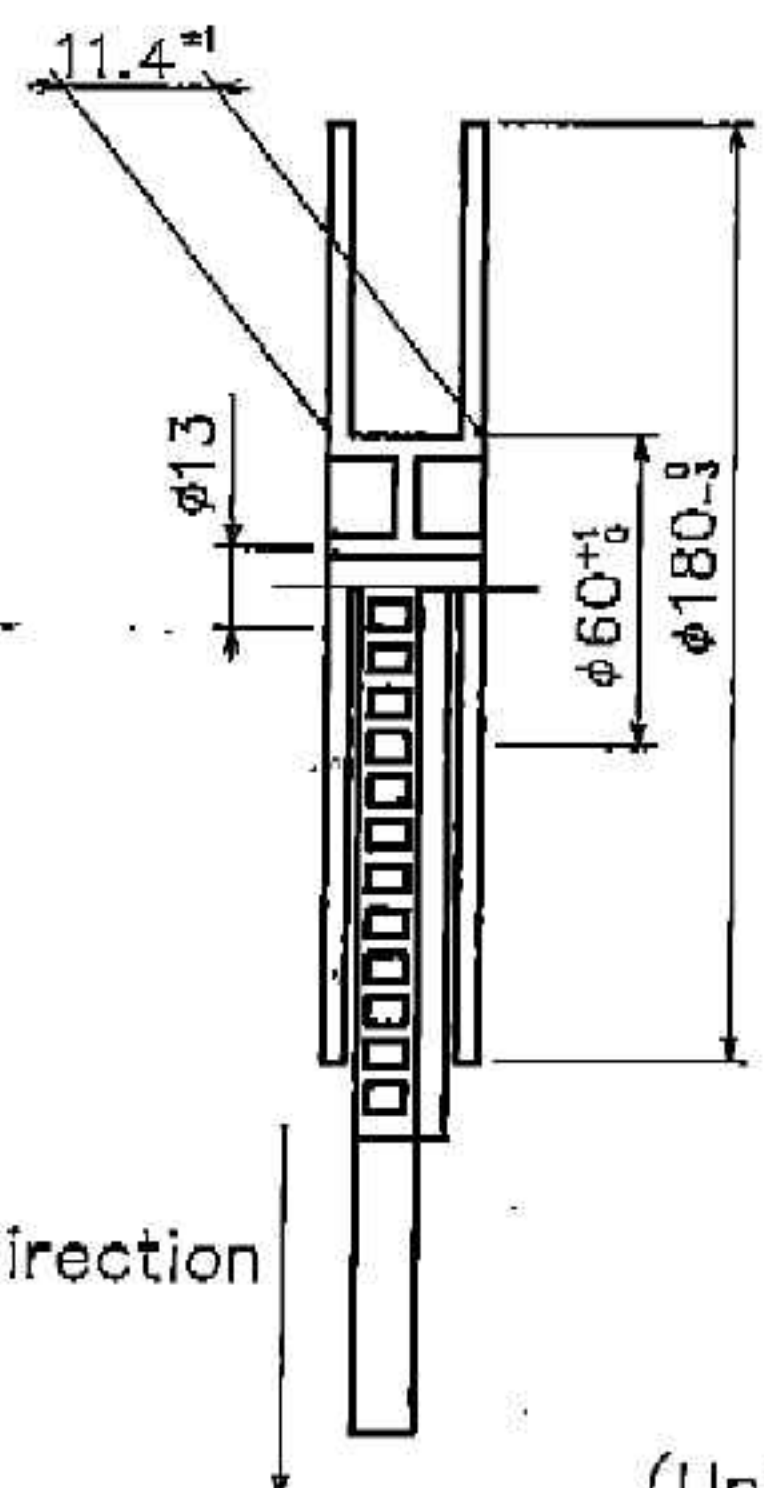

Pull direction

(Unit: mm)

(note) Tolerance is within ± 0.2 mm unless otherwise specified.



Specification	Products	Type
	SURFACE MOUNT LEDS (Side Light Type)	T87

5/6

SML-110 reel specification

Direction of liminous part

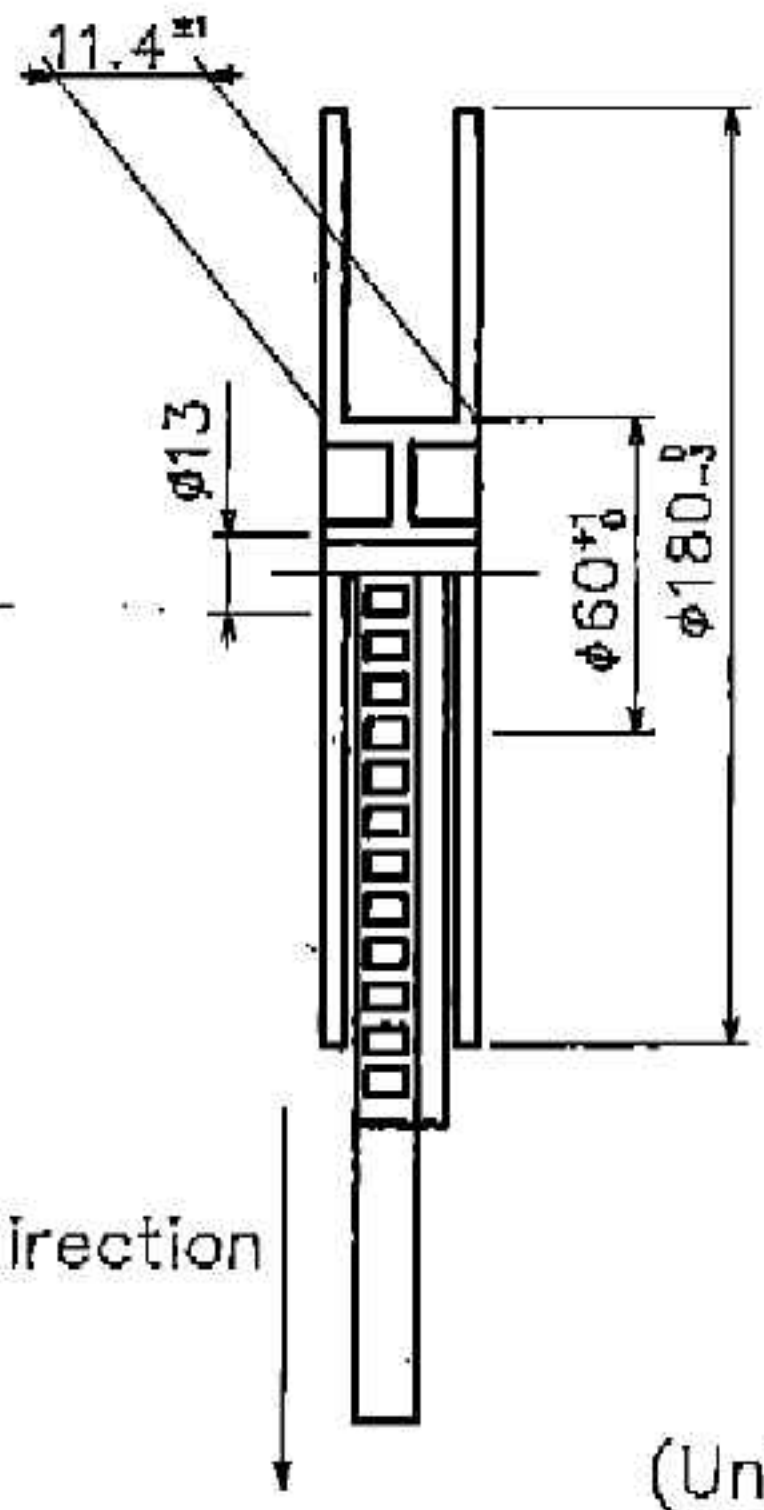
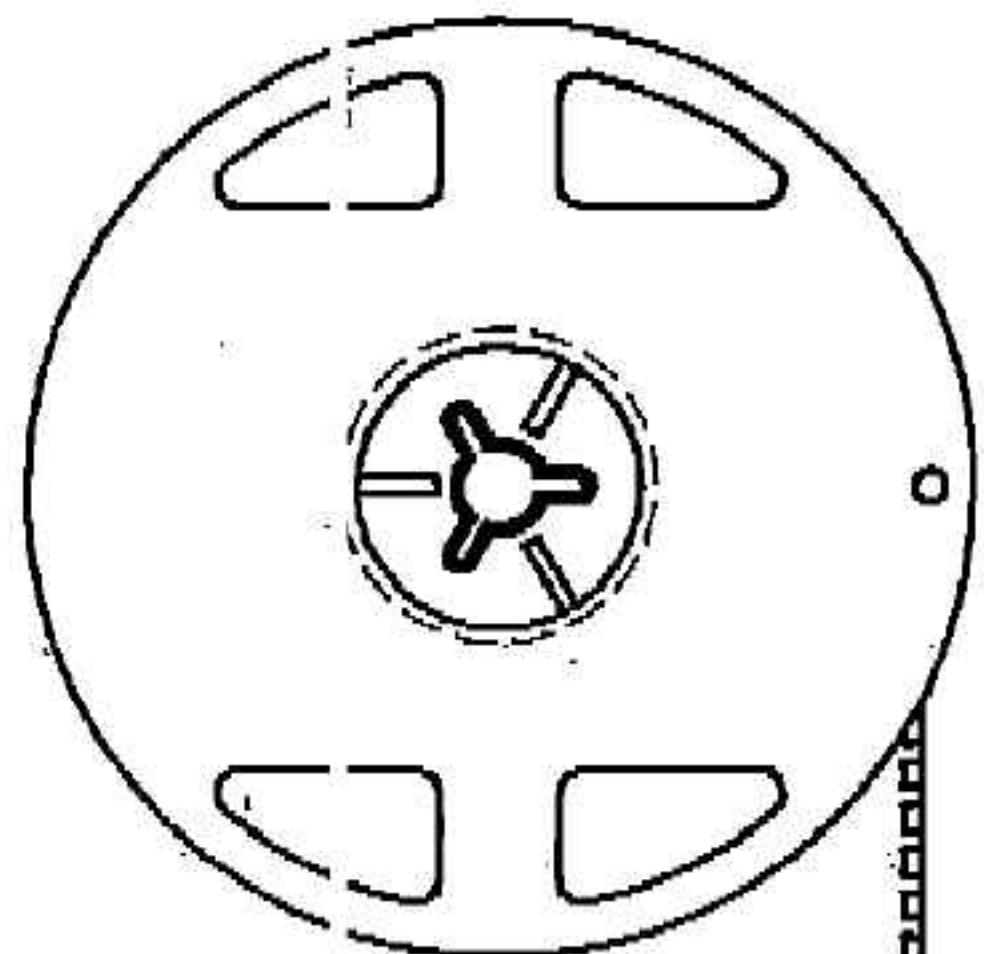
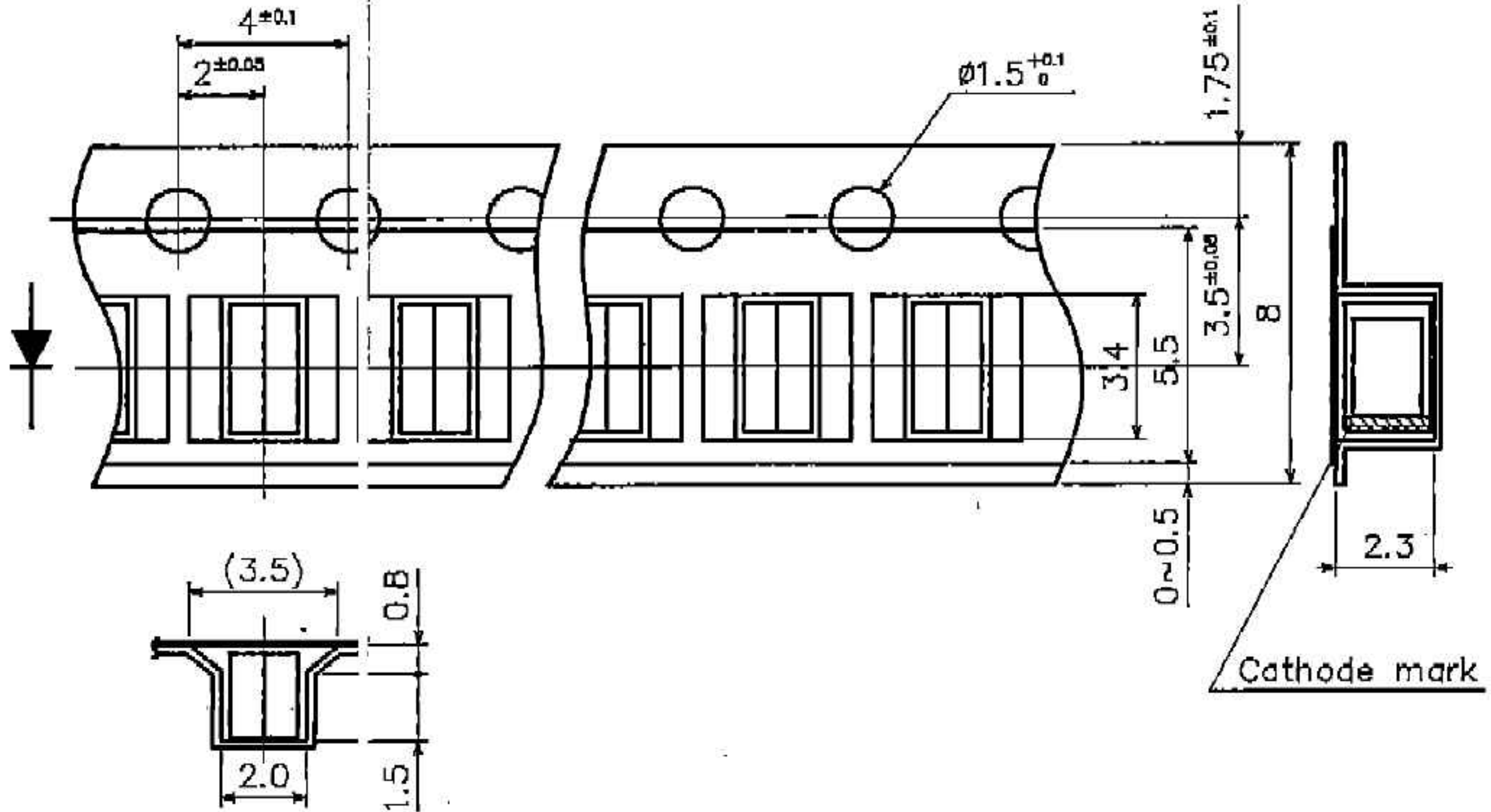

Packing quantity
2,000pcs/Reel

(Unit:mm)

(note) Tolerance is within ±0.2mm unless otherwise specified.

ROHM

Page of

Specification

Products

SURFACE MOUNT LED(Side Light Type)

Type

SML-110SERIES

ATTENTION POINTS IN HANDLING

THIS PRODUCT WAS DEVELOPED AS A SURFACE MOUNT LED ESPECIALLY SUITABLE FOR REFLOW SOLDERING. PLEASE TAKE CARE OF FOLLOWING POINTS WHEN USING THIS DEVICE. 6/6

1. DESIGNING OF PCB

AS FOR A RECOMMENDABLE SOLDER PATTERN, PLEASE REFER TO fig-1. THE SIZE AND DIRECTION OF THE PAD PATTERN DEPENDS ON THE CONDITION OF THE PCB, SO PLEASE INVESTIGATE ABOUT THE ADJACENT THOROUGHLY BEFORE DESIGNING.

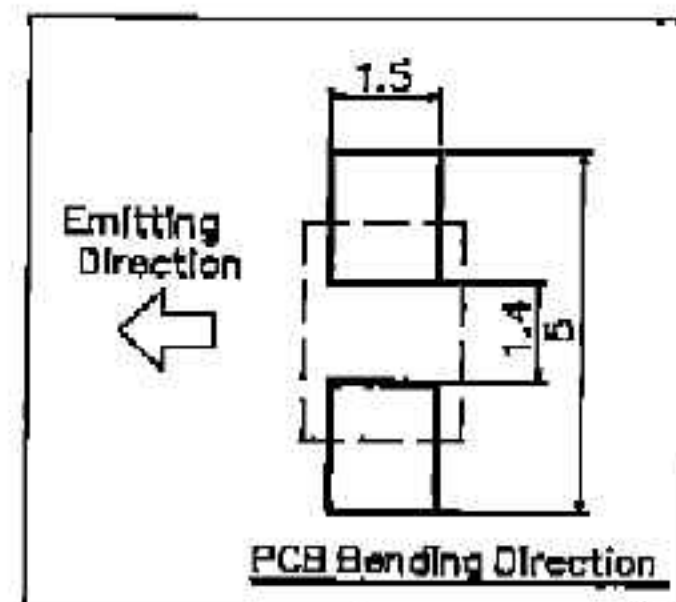
**2. SOLDERING**

LED PRODUCTS DO NOT CONTAIN REINFORCEMENT MATERIALS SUCH AS GLASS FILLERS. THEREFORE, THERMAL STRESS BY SOLDERING GREATLY INFLUENCES ITS RELIABILITY. THE TEMPERATURE CONDITIONS FOR REFLOW SOLDERING SHOULD THEREFORE BE SET UP ACCORDING TO THE CHARACTERISTIC OF THIS PRODUCT. (SEE fig-2) NUMBER OF REFLOW PROCESS SHALL BE LESS THAN 2 TIMES AND THESE PROCESS SHALL BE PERFORMED IN A ROW. COOLING PROCESS TO NORMAL TEMP. SHALL BE REQUIRED BETWEEN FIRST AND SECOND SOLDERING PROCESS.

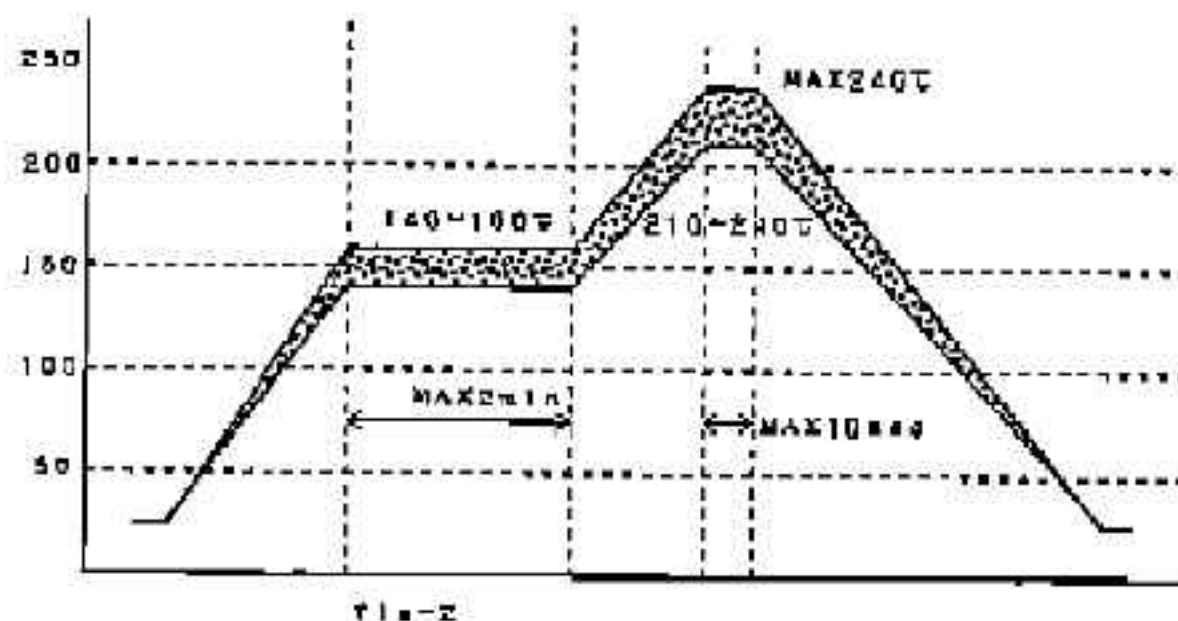
**3. HANDLING AFTER MOUNTING**

BY OVER 500g STRESS IN THE DIRECTION AS FIGURE, THE PART AND PCB MIGHT BE DAMAGED BECAUSE THE STRESS IS CONCENTRATED AROUND SOLDERING POINT. AFTER MOUNTING, MUCH ATTENTION IN HANDLING IS REQUIRED.

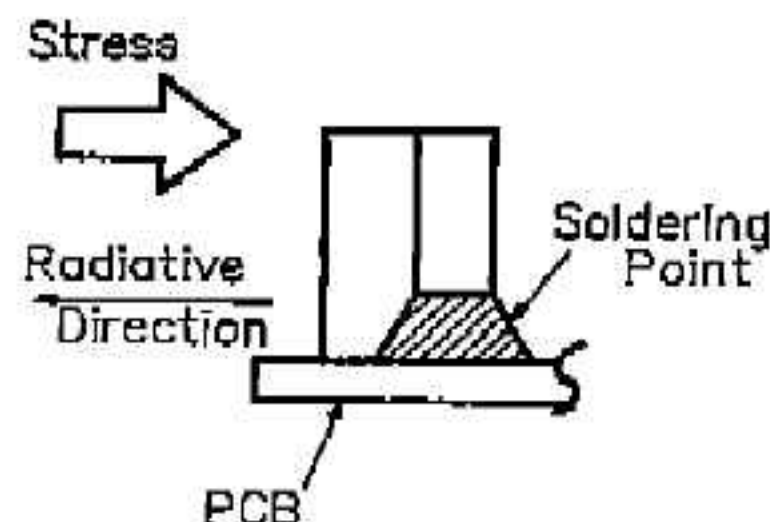
**4. WASHING**

PLEASE NOTE THE FOLLOWING POINTS WHEN WASHING IS REQUIRED AFTER SOLDERING.

4-1) WASHING SOLVENT

ISOPROPYL ALCOHOL OR OTHER ALCOHOLIC SOLVENT IS RECOMMENDABLE.

4-2) TEMPERATURE

BELOW 30°C, IMMERSION TIME: WITHIN 3 MINUTES

4-3) ULTRA SONIC WASHING

BELOW 15W/1 LITER OF SOLVENT TUB

4-4) CURING

BELOW 100°C WITHIN 3 MINUTES

5. STORAGE

AT REFLOW SOLDERING, THE RELIABILITY OF THIS PRODUCT IS OFTEN INFLUENCED BY MOISTURE ABSORPTION. SO WE APPLY THE PACKAGING WITH MOISTUREPROOF. FOR BETTER CONDITION IS USE, PLEASE ALSO NOTE THAT:

5-1) NOT TO BE OPENED BEFORE USING

5-2) TO BE KEPT IN OUR MOISTUREPROOF PACKAGING WITH SOME DESICCANT (SILICA GEL) AFTER OPENING IT. TO BE BAKED IN CASE THE SILICA GEL INDICATOR LOSES ITS BLUE COLOUR.

5-3) PLEASE USE WITHIN 168 HOURS AFTER THE PACKAGE WAS OPENED. (CONDITION AT 30°C, MAX. 70%RH)

IN CASE IT IS NOT USED WITHIN 168 HOURS, PLEASE PUT IT BACK INTO OUR PACKAGING.

5-4) BAKING

PLEASE BAKE UNDER DRY CONDITION AT 60°C, 12~24 HOURS (MAX. 20%RH) AFTER UN-SEALING.

WHILE BAKING IS DONE, THE REEL AND THE EMBOSS TAPE MAY BE EASILY DEFORMED.

PLEASE BE CAREFUL NOT TO GIVE ANY STRESS.

ROHM CO., LTD.

Date

AUG/1/95