

Micro-Power Voltage Detectors

General Description

The RT9818 is a micro-power voltage detector supervising the power supply voltage level for microprocessors (μ P) or digital systems. It provides internally fixed threshold levels with 0.1V per step ranging from 1.2V to 5V, which covers most digital applications. It features low supply current of 3 μ A. The RT9818 performs supervisory function by sending out a reset signal whenever the V_{DD} voltage falls below a preset threshold level. This reset signal will last the whole period before V_{DD} recovering. Once V_{DD} recovered upcrossing the threshold level, the reset signal will be released after a certain delay time. RT9818 is provided in SC-82, SC-70-3, SOT-23-3, SOT-23-5 and SOT-89 packages.

Ordering Information

RT9818	□	□	□	□	□
					Package Type
				U3	: SC-70-3
				V	: SOT-23-3
				VL	: SOT-23-3 (L-Type)
				B	: SOT-23-5
				X	: SOT-89
				Y	: SC-82
				YR	: SC-82 (R-Type)
					Lead Plating System
				P	: Pb Free
				G	: Green (Halogen Free and Pb Free)
					Threshold Voltage
				12	: 1.2V
				13	: 1.3V
				:	:
				49	: 4.9V
				50	: 5.0V
					Reset Active Timeout Period
				A	= 0ms ($\overline{\text{RESET}}$)
				B	= 55ms ($\overline{\text{RESET}}$)
				C	= 220ms ($\overline{\text{RESET}}$)
				D	= 450ms ($\overline{\text{RESET}}$)
				E	= 0ms (RESET)
				F	= 55ms (RESET)
				G	= 220ms (RESET)
				H	= 450ms (RESET)

Note :

Richtek products are :

- ▶ RoHS compliant and compatible with the current requirements of IPC/JEDEC J-STD-020.
- ▶ Suitable for use in SnPb or Pb-free soldering processes.

Features

- Internally Fixed Threshold 1.2V to 5V in 0.1V Step
- High Accuracy $\pm 1.5\%$
- Low Supply Current 3 μ A
- No External Components Required
- Quick Reset within 20 μ s
- Built-in Recovery Delay Include 0ms, 55ms, 220ms, 450ms Options
- Low Functional Supply Voltage 0.9V
- N-Channel Open-Drain Output
- Small SC-82, SC-70-3, SOT-23-3, SOT-23-5, SOT-89 Packages
- RoHS Compliant and 100% Lead (Pb)-Free

Applications

- Computers
- Controllers
- Intelligent Instruments
- Critical μ P and μ C Power Monitoring
- Portable/Battery-Powered Equipment

Marking Information

For marking information, contact our sales representative directly or through a Richtek distributor located in your area.

Typical Application Circuit

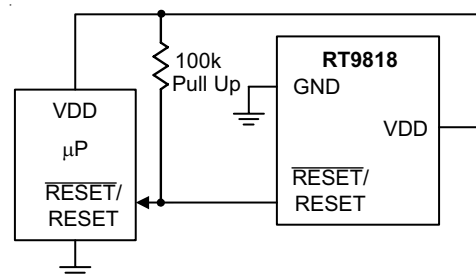

Pin Configurations

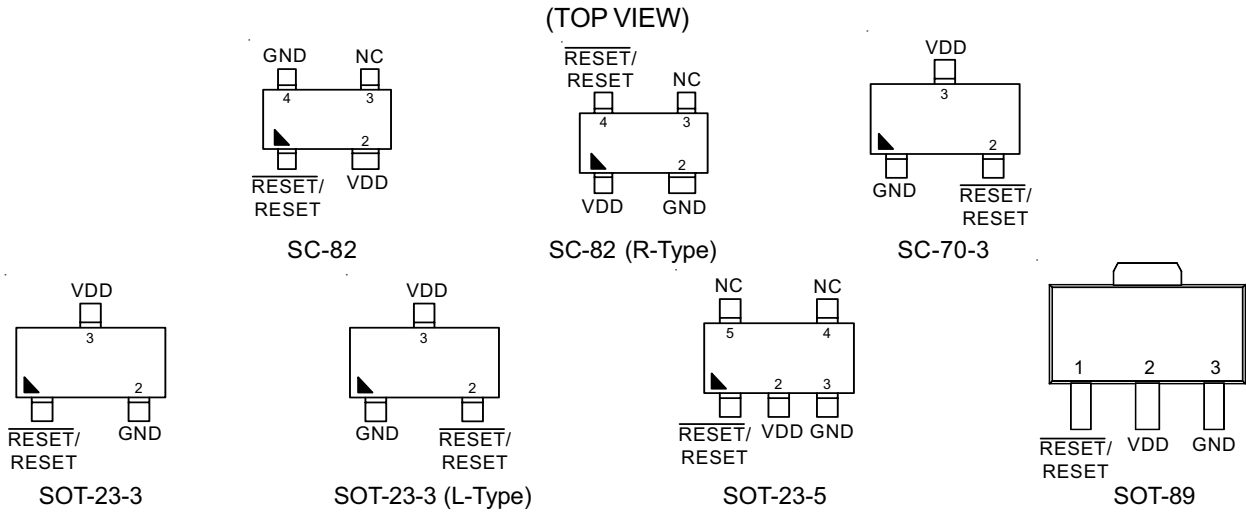

Functional Pin Description

Pin Name	Pin Function
GND	Ground
RESET	Active Low Open-Drain Reset Output
RESET	Active High Open-Drain Reset Output
VDD	Power Pin

Function Block Diagram

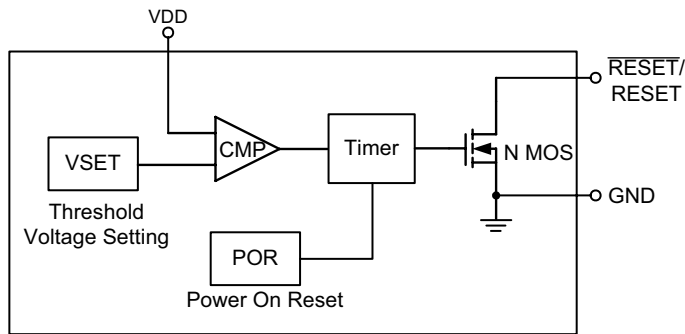

Timing Diagram

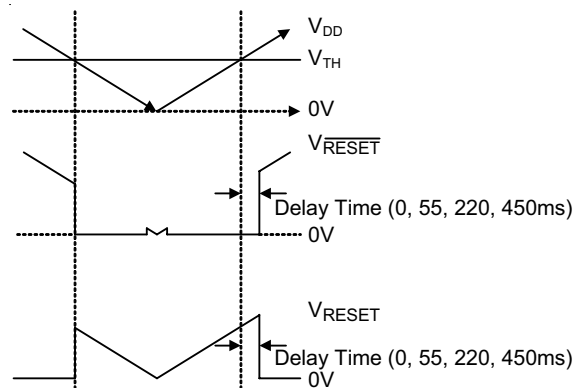

Absolute Maximum Ratings (Note 1)

- Terminal Voltage (with Respect to GND)
 - V_{DD} ----- -0.3V to 6V
- All Other Inputs ----- -0.3V to ($V_{DD} + 0.3V$)
- Input Current, I_{VDD} ----- 20mA
- Power Dissipation, P_D @ $T_A = 25^\circ C$
 - SC-70 / SC-82 ----- 0.25W
 - SOT-23-3 ----- 0.4W
 - SOT-23-5 ----- 0.4W
 - SOT-89 ----- 0.55W
- Package Thermal Resistance (Note 2)
 - SC-70 / SC-82, θ_{JA} ----- $400^\circ C/W$
 - SOT-23-3, θ_{JA} ----- $250^\circ C/W$
 - SOT-23-5, θ_{JA} ----- $250^\circ C/W$
 - SOT-89, θ_{JA} ----- $180^\circ C/W$
- Lead Temperature (Soldering, 10sec.) ----- $260^\circ C$
- Storage Temperature Range ----- $-65^\circ C$ to $125^\circ C$
- ESD Susceptibility (Note 3)
 - HBM (Human Body Mode) ----- 2kV
 - MM (Machine Mode) ----- 200V

Recommended Operating Conditions (Note 4)

- Junction Temperature Range ----- $-40^\circ C$ to $125^\circ C$
- Ambient Temperature Range ----- $-40^\circ C$ to $85^\circ C$

Electrical Characteristics

($V_{DD} = 3V$, unless otherwise specified)

Parameter	Symbol	Test Conditions	Min	Typ	Max	Unit
Operating V_{DD} (V_{OUT}) Range	V_{DD}		0.9	–	6	V
Supply Current	I_{DD}	$V_{TH} = 3V, V_{DD} = 4.5V, T_A = 27^\circ C$	--	3	8	μA
Reset Threshold	V_{TH}	$T_A = 27^\circ C$	--	1.2 to 5	--	V
Threshold Voltage Accuracy	ΔV_{TH}	$T_A = 27^\circ C$	-1.5	–	1.5	%
V_{DD} Drop to Reset Delay	t_{RD}	Drop = $V_{TH} - 125mV$	--	20	--	μs
Reset Active Time Out Period	RT9818A/E	t_{RP} $V_{DD} \geq 1.02 \times V_{TH}$	--	0	--	ms
	RT9818B/F		35	55	75	
	RT9818C/G		143	220	297	
	RT9818D/H		292	450	608	
RESET Output Voltage Low (Note 5)	V_{OL}	$3 = V_{DD} < V_{TH} I_{SINK} > 3.5mA$	--	–	0.4	V
Hysteresis Width	V_{HYS}		--	$0.01V_{TH}$	$0.016V_{TH}$	V

- Note 1.** Stresses listed as the above "Absolute Maximum Ratings" may cause permanent damage to the device. These are for stress ratings. Functional operation of the device at these or any other conditions beyond those indicated in the operational sections of the specifications is not implied. Exposure to absolute maximum rating conditions for extended periods may remain possibility to affect device reliability.
- Note 2.** θ_{JA} is measured in the natural convection at $T_A = 25^\circ\text{C}$ on a low effective thermal conductivity test board of JEDEC 51-3 thermal measurement standard.
- Note 3.** Devices are ESD sensitive. Handling precaution is recommended.
- Note 4.** The device is not guaranteed to function outside its operating conditions.
- Note 5.** The voltage V_{OL} can be calculated by $V_{OL} = V_{DD} - I_r * R$. Where R is the pull-up resistor and I_r is the current flowing through the pull-up resistor. For typical application ($R=100\text{k}\Omega$), V_{OL} is less than 0.2V.

Typical Operating Characteristics

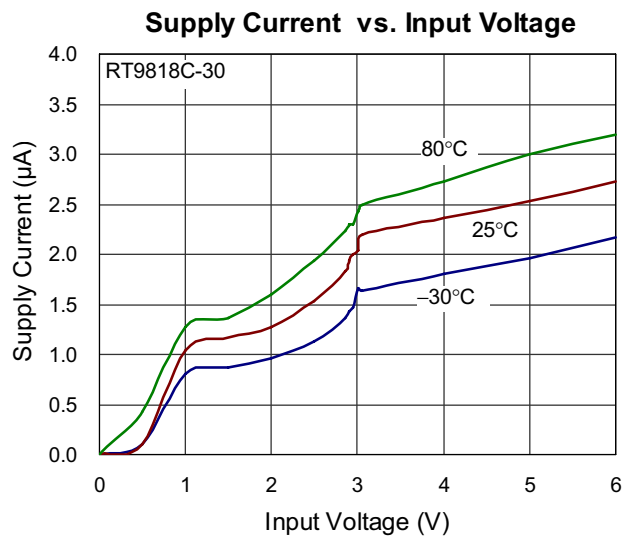
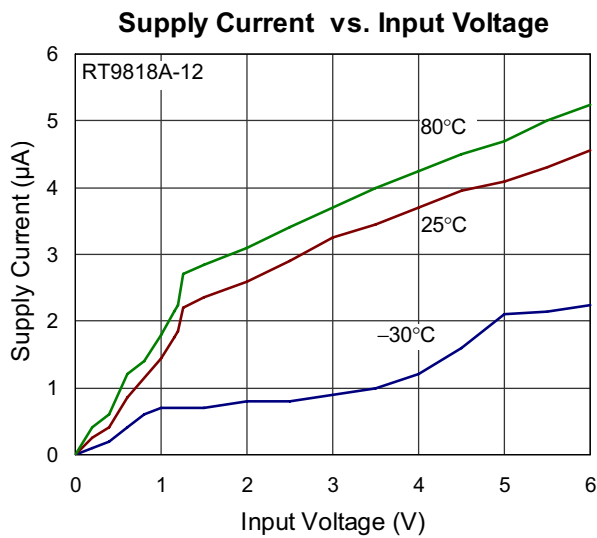
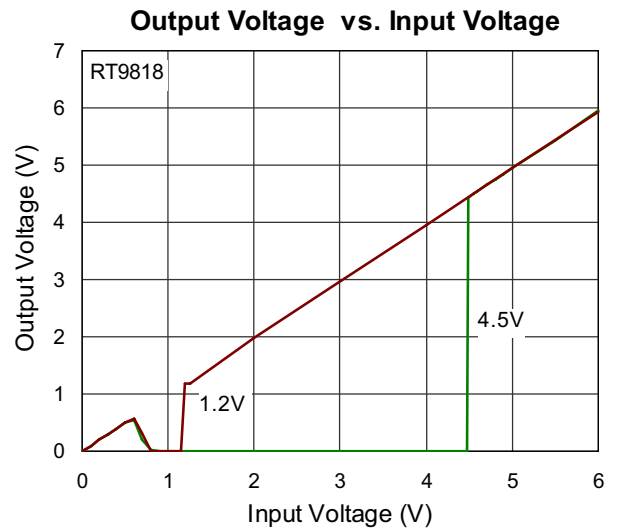
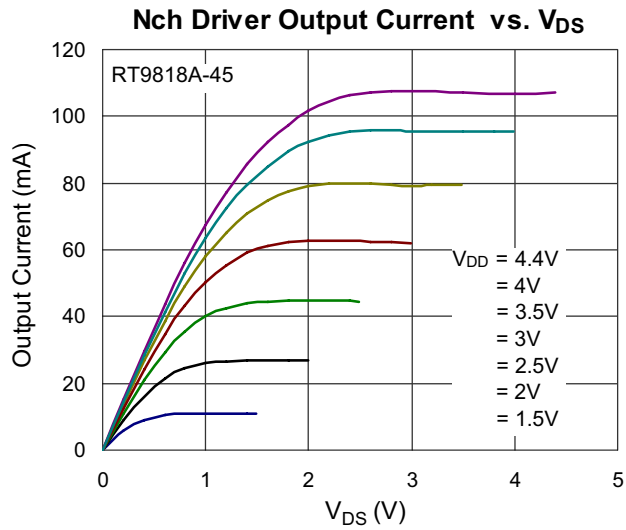
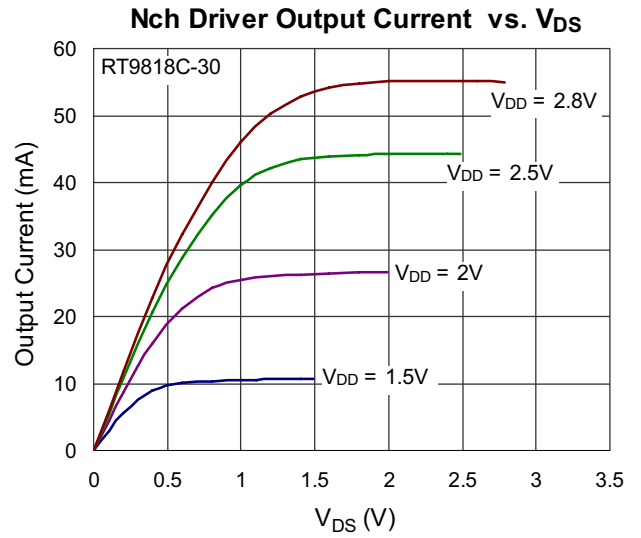
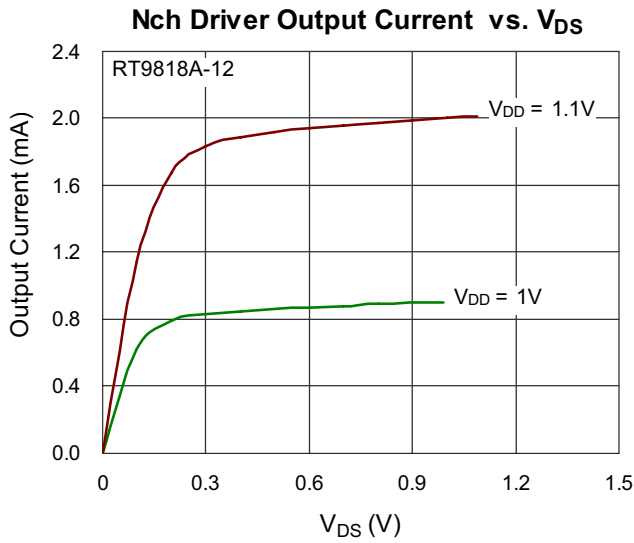

Supply Current vs. Input Voltage

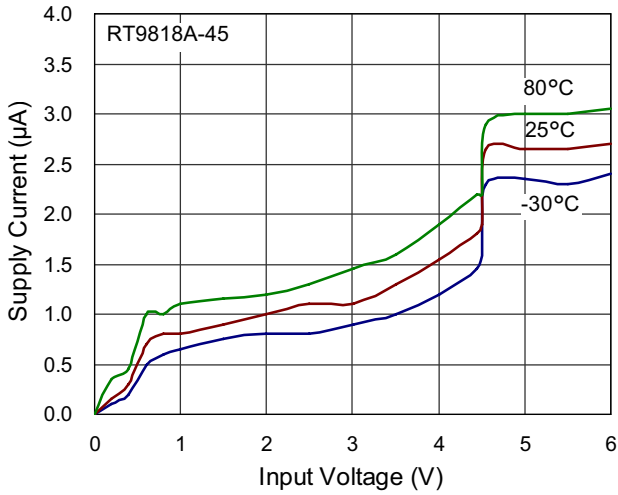

Power Down Reset Delay vs. Temperature

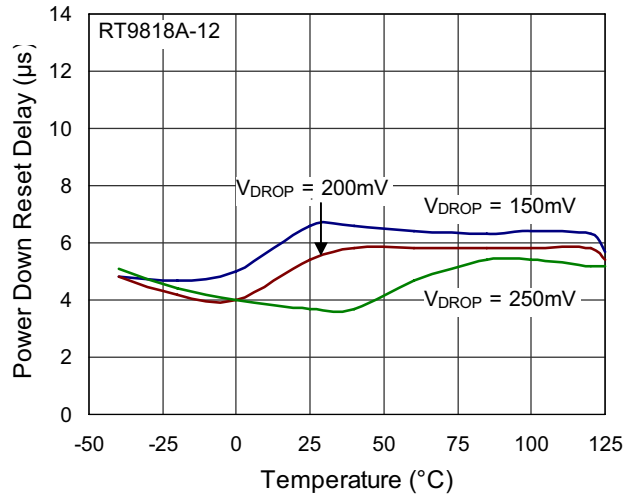

Power Down Reset Delay vs. Temperature

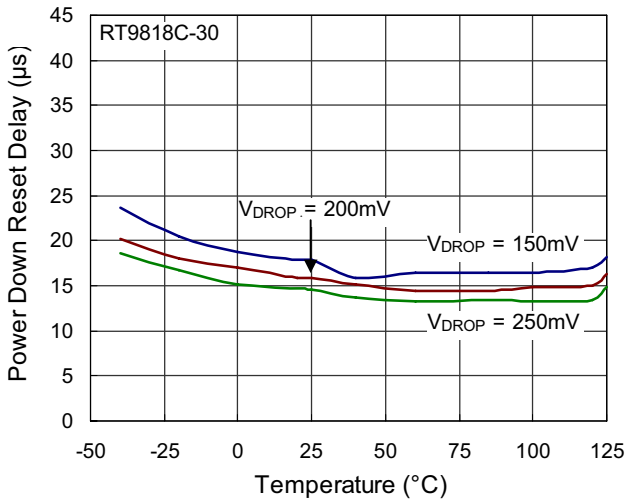

Power Down Reset Delay vs. Temperature

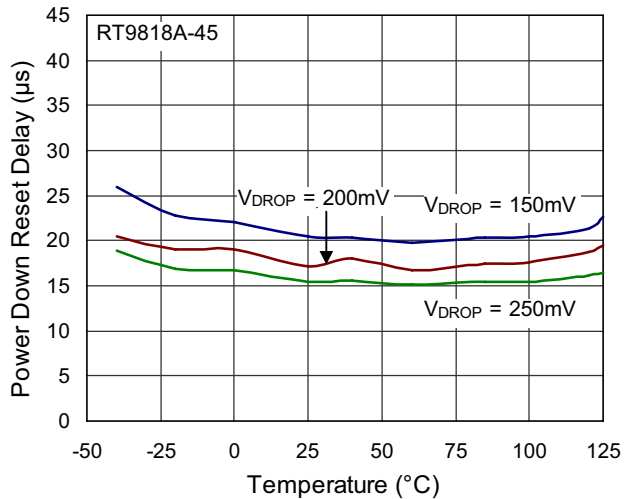

Reset Threshold Deviation vs. Temperature

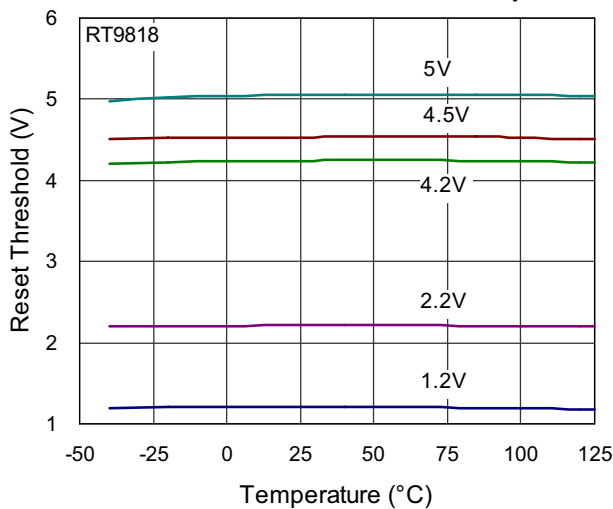

Nch Driver Sink Current vs. Input Voltage

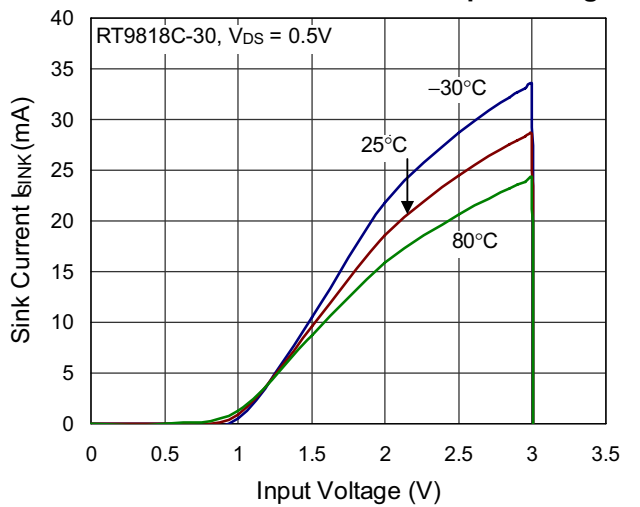

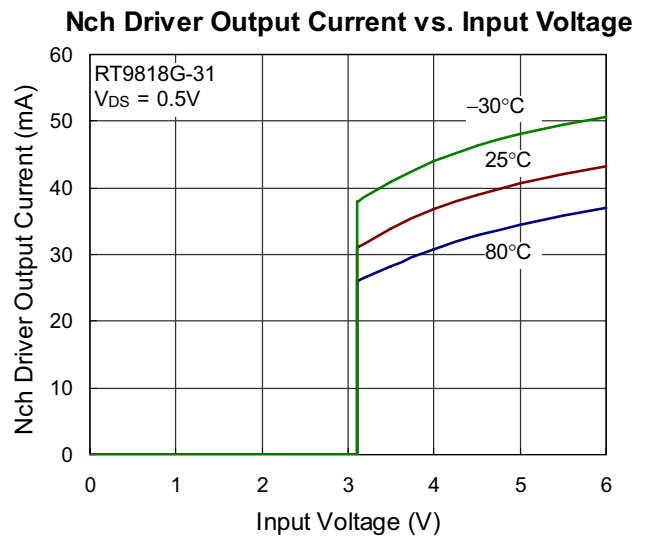
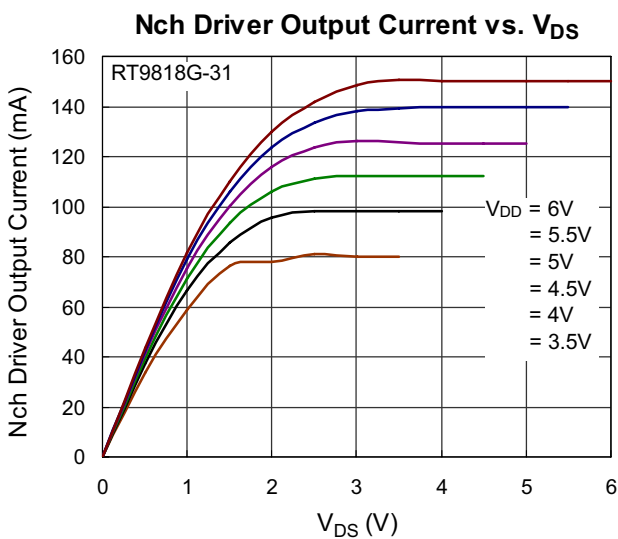
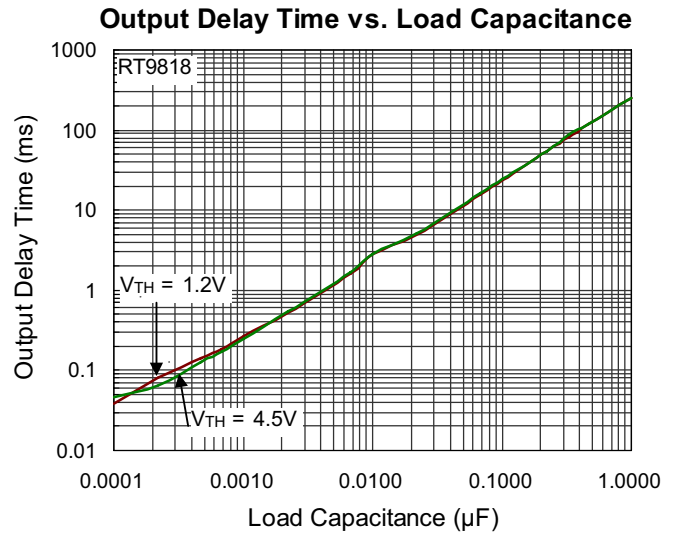
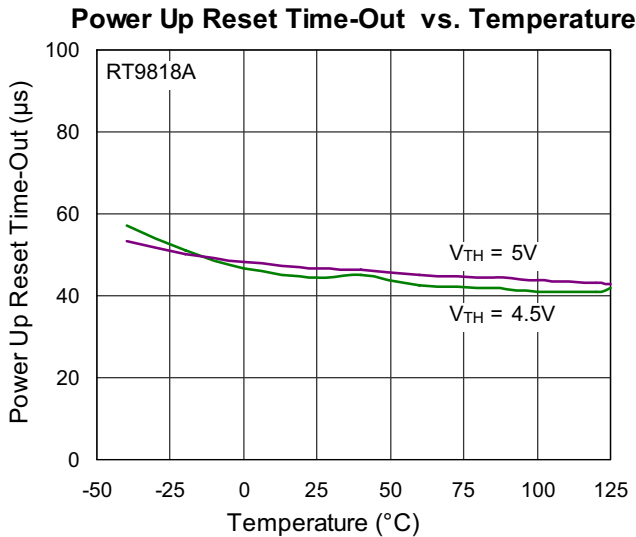
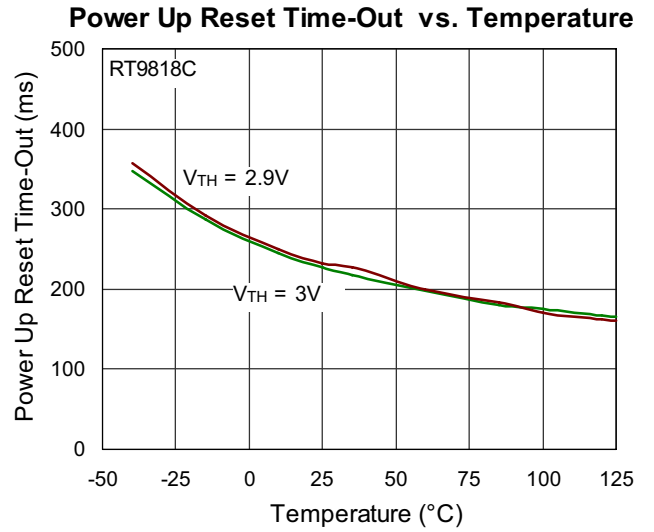
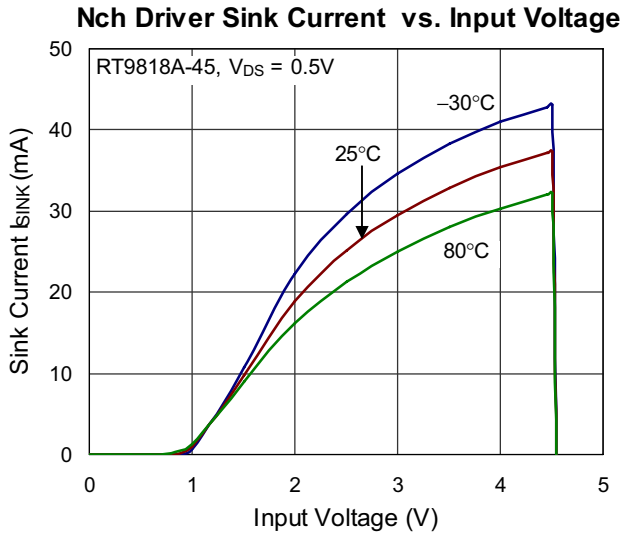

Power Down Reset Time-Out vs. Temperature

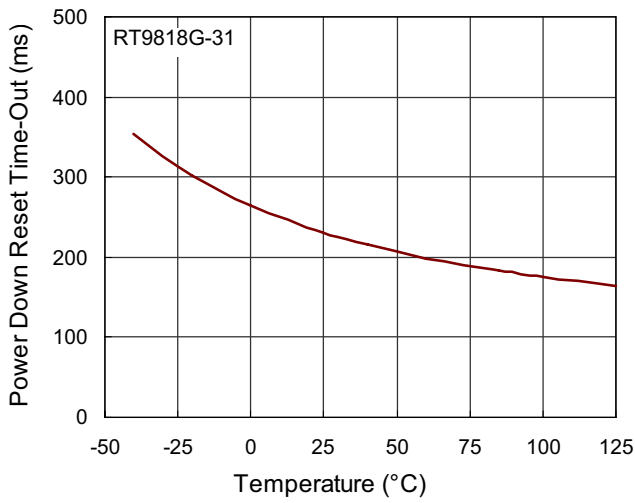

Output Voltage vs. Input Voltage

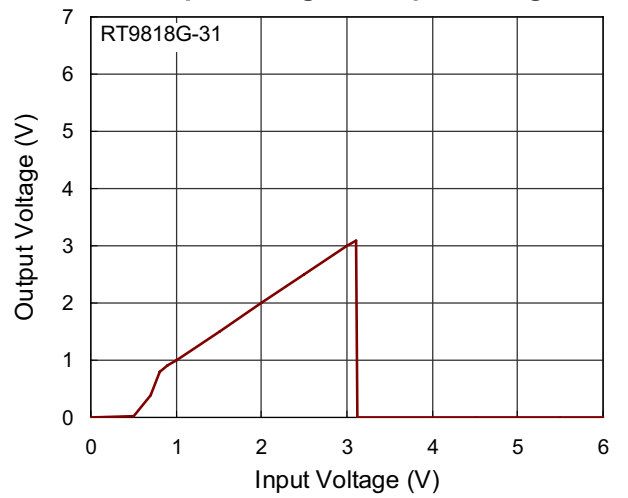

Power Down Reset Time-Out vs. Temperature

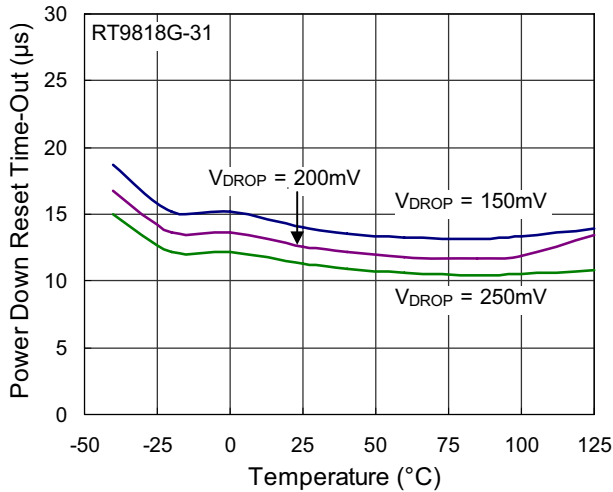

Threshold Voltage vs. Temperature

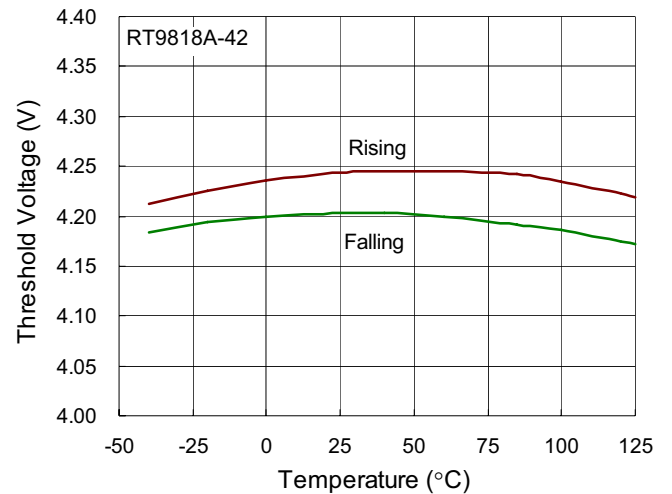

Threshold Voltage vs. Temperature

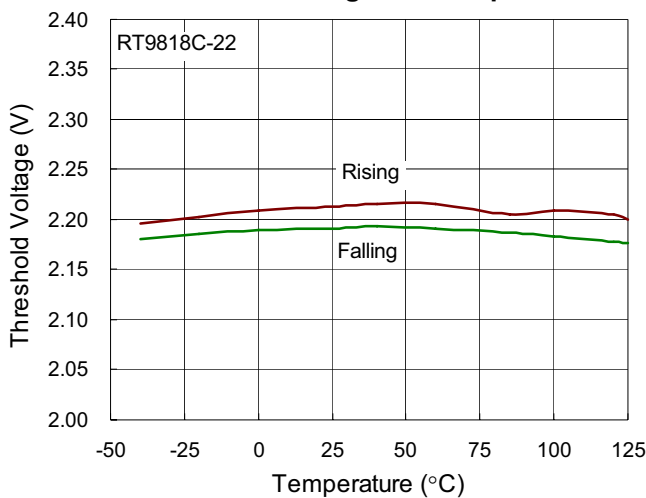

Application Information

Multiple Supplies

Mainly, the pull-up connected to the RT9818 will connect to the supply voltage that is being monitored at the IC's VDD pin. However, some systems may use the open-drain output to level-shift from the monitored supply to reset circuitry powered by some other supply.

Benefits of Highly Accurate Reset Threshold

Most μ P supervisor ICs have reset threshold voltages between 1% and 1.5% below the value of nominal supply voltages. This ensures a reset will not occur within 1% of the nominal supply, but will occur when the supply is 1.5% below nominal.

Outline Dimension

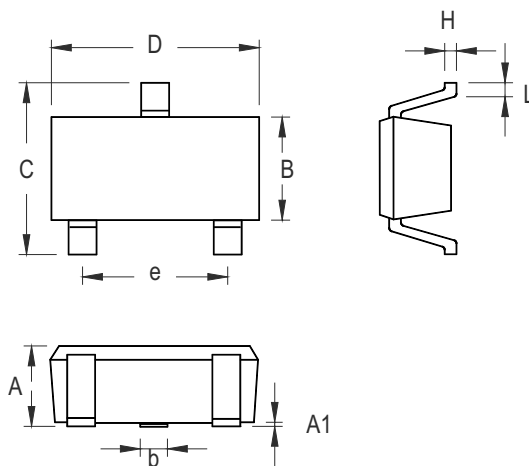

Symbol	Dimensions In Millimeters		Dimensions In Inches	
	Min	Max	Min	Max
A	0.800	1.100	0.031	0.044
A1	0.000	0.100	0.000	0.004
B	1.150	1.350	0.045	0.054
b	0.150	0.400	0.006	0.016
C	1.800	2.450	0.071	0.096
D	1.800	2.250	0.071	0.089
e	1.300		0.051	
H	0.080	0.260	0.003	0.010
L	0.210	0.460	0.008	0.018

SC-70-3 Surface Mount Package

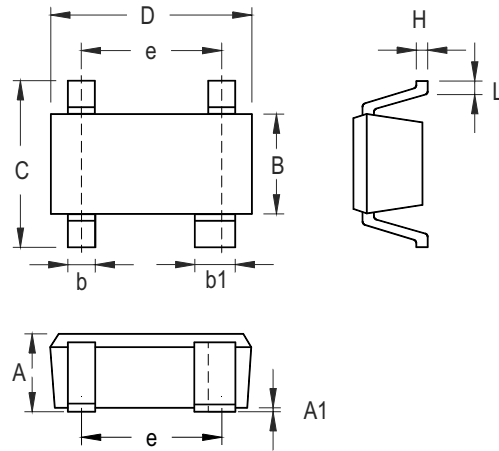

Symbol	Dimensions In Millimeters		Dimensions In Inches	
	Min	Max	Min	Max
A	0.800	1.100	0.031	0.043
A1	0.000	0.100	0.000	0.004
B	1.150	1.350	0.045	0.053
b	0.150	0.400	0.006	0.016
b1	0.350	0.500	0.014	0.020
C	1.800	2.450	0.071	0.096
D	1.800	2.200	0.071	0.087
e	1.300		0.051	
H	0.080	0.260	0.003	0.010
L	0.200	0.460	0.008	0.018

SC-82 Surface Mount Package

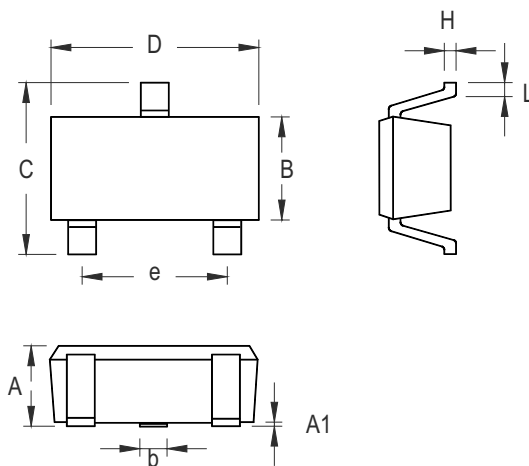

Symbol	Dimensions In Millimeters		Dimensions In Inches	
	Min	Max	Min	Max
A	0.889	1.295	0.035	0.051
A1	0.000	0.152	0.000	0.006
B	1.397	1.803	0.055	0.071
b	0.356	0.508	0.014	0.020
C	2.591	2.997	0.102	0.118
D	2.692	3.099	0.106	0.122
e	1.803	2.007	0.071	0.079
H	0.080	0.254	0.003	0.010
L	0.300	0.610	0.012	0.024

SOT-23-3 Surface Mount Package

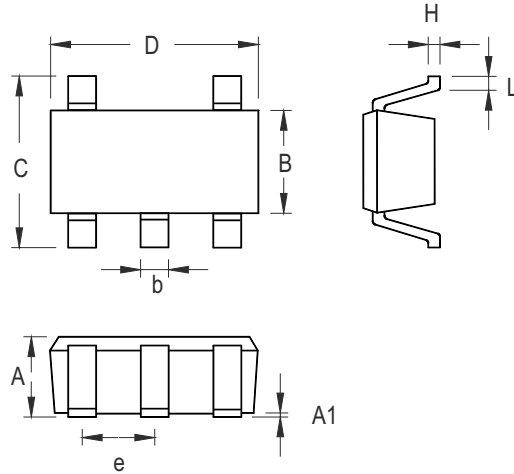

Symbol	Dimensions In Millimeters		Dimensions In Inches	
	Min	Max	Min	Max
A	0.889	1.295	0.035	0.051
A1	0.000	0.152	0.000	0.006
B	1.397	1.803	0.055	0.071
b	0.356	0.559	0.014	0.022
C	2.591	2.997	0.102	0.118
D	2.692	3.099	0.106	0.122
e	0.838	1.041	0.033	0.041
H	0.080	0.254	0.003	0.010
L	0.300	0.610	0.012	0.024

SOT-23-5 Surface Mount Package

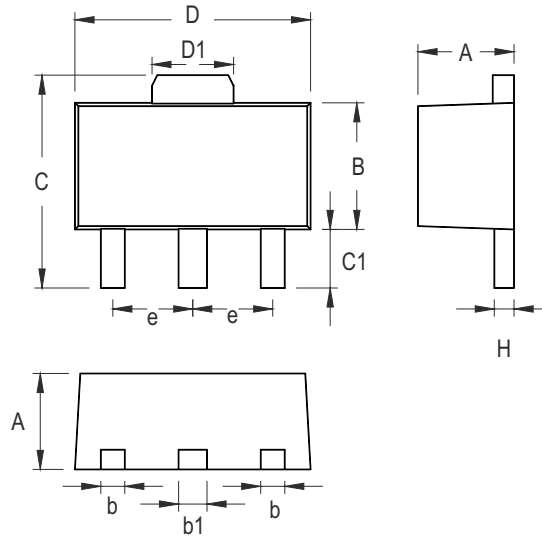

Symbol	Dimensions In Millimeters		Dimensions In Inches	
	Min	Max	Min	Max
A	1.397	1.600	0.055	0.063
b	0.356	0.483	0.014	0.019
B	2.388	2.591	0.094	0.102
b1	0.406	0.533	0.016	0.021
C	3.937	4.242	0.155	0.167
C1	0.787	1.194	0.031	0.047
D	4.394	4.597	0.173	0.181
D1	1.397	1.753	0.055	0.069
e	1.448	1.549	0.057	0.061
H	0.356	0.432	0.014	0.017

3-Lead SOT-89 Surface Mount Package

Richtek Technology Corporation

Headquarter
 5F, No. 20, Taiyuen Street, Chupei City
 Hsinchu, Taiwan, R.O.C.
 Tel: (8863)5526789 Fax: (8863)5526611

Richtek Technology Corporation

Taipei Office (Marketing)
 5F, No. 95, Minchiuan Road, Hsintien City
 Taipei County, Taiwan, R.O.C.
 Tel: (8862)86672399 Fax: (8862)86672377
 Email: marketing@richtek.com

Information that is provided by Richtek Technology Corporation is believed to be accurate and reliable. Richtek reserves the right to make any change in circuit design, specification or other related things if necessary without notice at any time. No third party intellectual property infringement of the applications should be guaranteed by users when integrating Richtek products into any application. No legal responsibility for any said applications is assumed by Richtek.