

Part No.	"A" mm
CBSS-8-01	10.9
CBSS-10-01	14.0
CBSS-12-01	17.3
CBSS-14-01	20.3

Part Number MB-1-156 to top off stack.

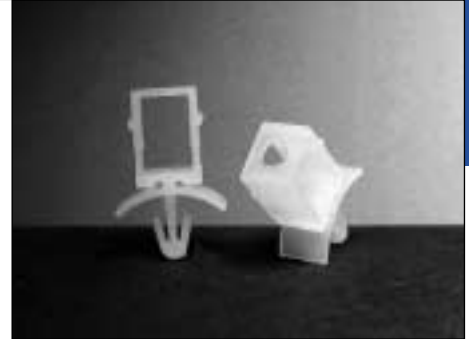
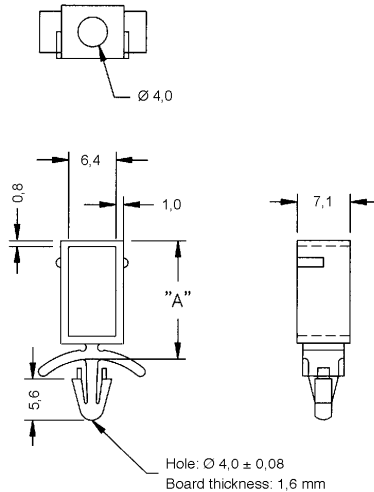

**CBSS**

CIRCUIT BOARD STACKING SPACER

Material: Nylon 6/6 - natural; UL 94 V-2, RMS-01  
by special order:  
Nylon 6/6 - natural; UL 94 V-0, RMS-19  
Std. Pk.: 1.000 pcs.

Note:

CBSS	7	01
Part	Length	Material Code