

To our customers,

Old Company Name in Catalogs and Other Documents

On April 1st, 2010, NEC Electronics Corporation merged with Renesas Technology Corporation, and Renesas Electronics Corporation took over all the business of both companies. Therefore, although the old company name remains in this document, it is a valid Renesas Electronics document. We appreciate your understanding.

Renesas Electronics website: <http://www.renesas.com>

April 1st, 2010
Renesas Electronics Corporation

Issued by: Renesas Electronics Corporation (<http://www.renesas.com>)

Send any inquiries to <http://www.renesas.com/inquiry>.

Notice

1. All information included in this document is current as of the date this document is issued. Such information, however, is subject to change without any prior notice. Before purchasing or using any Renesas Electronics products listed herein, please confirm the latest product information with a Renesas Electronics sales office. Also, please pay regular and careful attention to additional and different information to be disclosed by Renesas Electronics such as that disclosed through our website.
2. Renesas Electronics does not assume any liability for infringement of patents, copyrights, or other intellectual property rights of third parties by or arising from the use of Renesas Electronics products or technical information described in this document. No license, express, implied or otherwise, is granted hereby under any patents, copyrights or other intellectual property rights of Renesas Electronics or others.
3. You should not alter, modify, copy, or otherwise misappropriate any Renesas Electronics product, whether in whole or in part.
4. Descriptions of circuits, software and other related information in this document are provided only to illustrate the operation of semiconductor products and application examples. You are fully responsible for the incorporation of these circuits, software, and information in the design of your equipment. Renesas Electronics assumes no responsibility for any losses incurred by you or third parties arising from the use of these circuits, software, or information.
5. When exporting the products or technology described in this document, you should comply with the applicable export control laws and regulations and follow the procedures required by such laws and regulations. You should not use Renesas Electronics products or the technology described in this document for any purpose relating to military applications or use by the military, including but not limited to the development of weapons of mass destruction. Renesas Electronics products and technology may not be used for or incorporated into any products or systems whose manufacture, use, or sale is prohibited under any applicable domestic or foreign laws or regulations.
6. Renesas Electronics has used reasonable care in preparing the information included in this document, but Renesas Electronics does not warrant that such information is error free. Renesas Electronics assumes no liability whatsoever for any damages incurred by you resulting from errors in or omissions from the information included herein.
7. Renesas Electronics products are classified according to the following three quality grades: "Standard", "High Quality", and "Specific". The recommended applications for each Renesas Electronics product depends on the product's quality grade, as indicated below. You must check the quality grade of each Renesas Electronics product before using it in a particular application. You may not use any Renesas Electronics product for any application categorized as "Specific" without the prior written consent of Renesas Electronics. Further, you may not use any Renesas Electronics product for any application for which it is not intended without the prior written consent of Renesas Electronics. Renesas Electronics shall not be in any way liable for any damages or losses incurred by you or third parties arising from the use of any Renesas Electronics product for an application categorized as "Specific" or for which the product is not intended where you have failed to obtain the prior written consent of Renesas Electronics. The quality grade of each Renesas Electronics product is "Standard" unless otherwise expressly specified in a Renesas Electronics data sheets or data books, etc.

"Standard": Computers; office equipment; communications equipment; test and measurement equipment; audio and visual equipment; home electronic appliances; machine tools; personal electronic equipment; and industrial robots.

"High Quality": Transportation equipment (automobiles, trains, ships, etc.); traffic control systems; anti-disaster systems; anti-crime systems; safety equipment; and medical equipment not specifically designed for life support.

"Specific": Aircraft; aerospace equipment; submersible repeaters; nuclear reactor control systems; medical equipment or systems for life support (e.g. artificial life support devices or systems), surgical implantations, or healthcare intervention (e.g. excision, etc.), and any other applications or purposes that pose a direct threat to human life.

8. You should use the Renesas Electronics products described in this document within the range specified by Renesas Electronics, especially with respect to the maximum rating, operating supply voltage range, movement power voltage range, heat radiation characteristics, installation and other product characteristics. Renesas Electronics shall have no liability for malfunctions or damages arising out of the use of Renesas Electronics products beyond such specified ranges.
9. Although Renesas Electronics endeavors to improve the quality and reliability of its products, semiconductor products have specific characteristics such as the occurrence of failure at a certain rate and malfunctions under certain use conditions. Further, Renesas Electronics products are not subject to radiation resistance design. Please be sure to implement safety measures to guard them against the possibility of physical injury, and injury or damage caused by fire in the event of the failure of a Renesas Electronics product, such as safety design for hardware and software including but not limited to redundancy, fire control and malfunction prevention, appropriate treatment for aging degradation or any other appropriate measures. Because the evaluation of microcomputer software alone is very difficult, please evaluate the safety of the final products or system manufactured by you.
10. Please contact a Renesas Electronics sales office for details as to environmental matters such as the environmental compatibility of each Renesas Electronics product. Please use Renesas Electronics products in compliance with all applicable laws and regulations that regulate the inclusion or use of controlled substances, including without limitation, the EU RoHS Directive. Renesas Electronics assumes no liability for damages or losses occurring as a result of your noncompliance with applicable laws and regulations.
11. This document may not be reproduced or duplicated, in any form, in whole or in part, without prior written consent of Renesas Electronics.
12. Please contact a Renesas Electronics sales office if you have any questions regarding the information contained in this document or Renesas Electronics products, or if you have any other inquiries.

(Note 1) "Renesas Electronics" as used in this document means Renesas Electronics Corporation and also includes its majority-owned subsidiaries.

(Note 2) "Renesas Electronics product(s)" means any product developed or manufactured by or for Renesas Electronics.

The revision list can be viewed directly by clicking the title page.

The revision list summarizes the locations of revisions and additions. Details should always be checked by referring to the relevant text.

H8S/2168Group

Hardware Manual

Renesas 16-Bit Single-Chip Microcomputer
H8S Family / H8S/2100 Series

H8S/2168 HD64F2168

H8S/2167 HD64F2167

H8S/2166 HD64F2166

Keep safety first in your circuit designs!

1. Renesas Technology Corp. puts the maximum effort into making semiconductor products better and more reliable, but there is always the possibility that trouble may occur with them. Trouble with semiconductors may lead to personal injury, fire or property damage.
Remember to give due consideration to safety when making your circuit designs, with appropriate measures such as (i) placement of substitutive, auxiliary circuits, (ii) use of nonflammable material or (iii) prevention against any malfunction or mishap.

Notes regarding these materials

1. These materials are intended as a reference to assist our customers in the selection of the Renesas Technology Corp. product best suited to the customer's application; they do not convey any license under any intellectual property rights, or any other rights, belonging to Renesas Technology Corp. or a third party.
2. Renesas Technology Corp. assumes no responsibility for any damage, or infringement of any third-party's rights, originating in the use of any product data, diagrams, charts, programs, algorithms, or circuit application examples contained in these materials.
3. All information contained in these materials, including product data, diagrams, charts, programs and algorithms represents information on products at the time of publication of these materials, and are subject to change by Renesas Technology Corp. without notice due to product improvements or other reasons. It is therefore recommended that customers contact Renesas Technology Corp. or an authorized Renesas Technology Corp. product distributor for the latest product information before purchasing a product listed herein.
The information described here may contain technical inaccuracies or typographical errors. Renesas Technology Corp. assumes no responsibility for any damage, liability, or other loss rising from these inaccuracies or errors.
Please also pay attention to information published by Renesas Technology Corp. by various means, including the Renesas Technology Corp. Semiconductor home page (<http://www.renesas.com>).
4. When using any or all of the information contained in these materials, including product data, diagrams, charts, programs, and algorithms, please be sure to evaluate all information as a total system before making a final decision on the applicability of the information and products. Renesas Technology Corp. assumes no responsibility for any damage, liability or other loss resulting from the information contained herein.
5. Renesas Technology Corp. semiconductors are not designed or manufactured for use in a device or system that is used under circumstances in which human life is potentially at stake. Please contact Renesas Technology Corp. or an authorized Renesas Technology Corp. product distributor when considering the use of a product contained herein for any specific purposes, such as apparatus or systems for transportation, vehicular, medical, aerospace, nuclear, or undersea repeater use.
6. The prior written approval of Renesas Technology Corp. is necessary to reprint or reproduce in whole or in part these materials.
7. If these products or technologies are subject to the Japanese export control restrictions, they must be exported under a license from the Japanese government and cannot be imported into a country other than the approved destination.
Any diversion or reexport contrary to the export control laws and regulations of Japan and/or the country of destination is prohibited.
8. Please contact Renesas Technology Corp. for further details on these materials or the products contained therein.

General Precautions on Handling of Product

1. Treatment of NC Pins

Note: Do not connect anything to the NC pins.

The NC (not connected) pins are either not connected to any of the internal circuitry or are used as test pins or to reduce noise. If something is connected to the NC pins, the operation of the LSI is not guaranteed.

2. Treatment of Unused Input Pins

Note: Fix all unused input pins to high or low level.

Generally, the input pins of CMOS products are high-impedance input pins. If unused pins are in their open states, intermediate levels are induced by noise in the vicinity, a pass-through current flows internally, and a malfunction may occur.

3. Processing before Initialization

Note: When power is first supplied, the product's state is undefined.

The states of internal circuits are undefined until full power is supplied throughout the chip and a low level is input on the reset pin. During the period where the states are undefined, the register settings and the output state of each pin are also undefined. Design your system so that it does not malfunction because of processing while it is in this undefined state. For those products which have a reset function, reset the LSI immediately after the power supply has been turned on.

4. Prohibition of Access to Undefined or Reserved Addresses

Note: Access to undefined or reserved addresses is prohibited.

The undefined or reserved addresses may be used to expand functions, or test registers may have been allocated to these addresses. Do not access these registers; the system's operation is not guaranteed if they are accessed.

Configuration of This Manual

This manual comprises the following items:

1. General Precautions on Handling of Product
2. Configuration of This Manual
3. Preface
4. Contents
5. Overview
6. Description of Functional Modules

- CPU and System-Control Modules
- On-Chip Peripheral Modules

The configuration of the functional description of each module differs according to the module. However, the generic style includes the following items:

- i) Feature
- ii) Input/Output Pin
- iii) Register Description
- iv) Operation
- v) Usage Note

When designing an application system that includes this LSI, take notes into account. Each section includes notes in relation to the descriptions given, and usage notes are given, as required, as the final part of each section.

7. List of Registers
8. Electrical Characteristics
9. Appendix
10. Main Revisions and Additions in this Edition (only for revised versions)

The list of revisions is a summary of points that have been revised or added to earlier versions. This does not include all of the revised contents. For details, see the actual locations in this manual.

11. Index

Preface

This LSI is a microcomputer (MCU) made up of the H8S/2000 CPU with Renesas Technology's original architecture as its core, and the peripheral functions required to configure a system, eg PC server.

The H8S/2000 CPU has an internal 32-bit configuration, sixteen 16-bit general registers, and a simple and optimized instruction set for high-speed operation. The H8S/2000 CPU can handle a 16-Mbyte linear address space. The instruction set of the H8S/2000 CPU maintains upward compatibility at the object level with the H8/300 and H8/300H CPUs. This allows the transition from the H8/300, H8/300L, or H8/300H to the H8S/2000 CPU.

This LSI is equipped with ROM, RAM, two kinds of PWM timers (PWM and PWMX), a 16-bit free running timer (FRT), an 8-bit timer (TMR), a watchdog timer (WDT), a serial communication interface (SCI), an I²C bus interface (IIC), an LPC interface (LPC), a D/A converter, an A/D converter, and I/O ports as on-chip peripheral modules required for system configuration.

A data transfer controller (DTC) is included as a bus master.

A flash memory (F-ZTAT^{TM*}) version is available for this LSI's 256, 384, and 512-kbyte ROM. The CPU and ROM are connected to a 16-bit bus, enabling byte data and word data to be accessed in a single state. This improves the instruction fetch and process speeds.

Two operating modes are provided, offering a choice of address space and single chip mode/external extended mode. Boot programming into a flash memory, on-chip emulation, and boundary scan can be selected as special operating modes.

Note: * F-ZTATTM is a trademark of Renesas Technology Corp.

Target Users: This manual was written for users who use this LSI in the design of application systems. Target users are expected to understand the fundamentals of electrical circuits, logic circuits, and microcomputers.

Objective: This manual was written to explain the hardware functions and electrical characteristics of this LSI to the target users.
Refer to the H8S/2600 Series, H8S/2000 Series Programming Manual for a detailed description of the instruction set.

Notes on reading this manual:

- In order to understand the overall functions of the chip
Read this manual in the order of the table of contents. This manual can be roughly categorized into the descriptions on the CPU, system control functions, peripheral functions and electrical characteristics.

- In order to understand the details of the CPU's functions
Read the H8S/2600 Series, H8S/2000 Series Programming Manual.
- In order to understand the detailed function of a register whose name is known
Read the index that is the final part of the manual to find the page number of the entry on the register. The addresses, bits, and initial values of the registers are summarized in section 24, List of Registers.

Rules: Register name: The following notation is used for cases when the same or a similar function, e.g., serial communication interface, is implemented on more than one channel:
XXX_N (XXX is the register name and N is the channel number)

 Bit order: The MSB is on the left and the LSB is on the right.

 Number notation: Binary is B'xxxx, hexadecimal is H'xxxx, decimal is xxxx.

 Signal notation: An overbar is added to a low-active signal: $\overline{\text{xxxx}}$

Related Manuals: The latest versions of all related manuals are available from our web site.
Please ensure you have the latest versions of all documents you require.
<http://www.renesas.com/eng/>

H8S/2168 Group manuals:

Document Title	Document No.
H8S/2168 Group Hardware Manual	This manual
H8S/2600 Series, H8S/2000 Series Programming Manual	ADE-602-083

User's manuals for development tools:

Document Title	Document No.
H8S, H8/300 Series C/C++ Compiler, Assembler, Optimizing Linkage Editor User's Manual	ADE-702-247
H8S, H8/300 Series Simulator/Debugger User's Manual	ADE-702-282
H8S, H8/300 Series High-performance Embedded Workshop, High-performance Debugging Interface Tutorial	ADE-702-231
High-performance Embedded Workshop User's Manual	ADE-702-201

Contents

Section 1	Overview.....	1
1.1	Overview.....	1
1.2	Internal Block Diagram.....	2
1.3	Pin Description.....	3
1.3.1	Pin Arrangement.....	3
1.3.2	Pin Arrangement in Each Operating Mode.....	4
1.3.3	Pin Functions	9
Section 2	CPU.....	15
2.1	Features.....	15
2.1.1	Differences between H8S/2600 CPU and H8S/2000 CPU	16
2.1.2	Differences from H8/300 CPU	17
2.1.3	Differences from H8/300H CPU.....	17
2.2	CPU Operating Modes.....	18
2.2.1	Normal Mode.....	18
2.2.2	Advanced Mode.....	20
2.3	Address Space.....	22
2.4	Register Configuration.....	23
2.4.1	General Registers.....	24
2.4.2	Program Counter (PC)	25
2.4.3	Extended Control Register (EXR)	25
2.4.4	Condition-Code Register (CCR).....	26
2.4.5	Initial Register Values.....	27
2.5	Data Formats.....	28
2.5.1	General Register Data Formats	28
2.5.2	Memory Data Formats	30
2.6	Instruction Set.....	31
2.6.1	Table of Instructions Classified by Function	32
2.6.2	Basic Instruction Formats	41
2.7	Addressing Modes and Effective Address Calculation.....	43
2.7.1	Register Direct—Rn	43
2.7.2	Register Indirect—@ERn.....	44
2.7.3	Register Indirect with Displacement—@(d:16, ERn) or @(d:32, ERn).....	44
2.7.4	Register Indirect with Post-Increment or Pre-Decrement—@ERn+ or @-ERn.....	44
2.7.5	Absolute Address—@aa:8, @aa:16, @aa:24, or @aa:32.....	44
2.7.6	Immediate—#xx:8, #xx:16, or #xx:32.....	45
2.7.7	Program-Counter Relative—@(d:8, PC) or @(d:16, PC).....	45
2.7.8	Memory Indirect—@@aa:8	46

2.7.9	Effective Address Calculation	47
2.8	Processing States.....	49
2.9	Usage Notes	51
2.9.1	Note on TAS Instruction Usage.....	51
2.9.2	Note on Bit Manipulation Instructions	51
2.9.3	EEPMOV Instruction.....	52
Section 3 MCU Operating Modes		53
3.1	Operating Mode Selection	53
3.2	Register Descriptions.....	54
3.2.1	Mode Control Register (MDCR)	54
3.2.2	System Control Register (SYSCR).....	55
3.2.3	Serial Timer Control Register (STCR)	56
3.3	Operating Mode Descriptions	58
3.3.1	Mode 2.....	58
3.3.2	Pin Functions in Each Operating Mode	58
3.4	Address Map.....	60
Section 4 Exception Handling		63
4.1	Exception Handling Types and Priority	63
4.2	Exception Sources and Exception Vector Table	64
4.3	Reset	66
4.3.1	Reset Exception Handling	66
4.3.2	Interrupts after Reset.....	67
4.3.3	On-Chip Peripheral Modules after Reset is Cancelled	67
4.4	Interrupt Exception Handling	68
4.5	Trap Instruction Exception Handling.....	68
4.6	Stack Status after Exception Handling.....	69
4.7	Usage Note.....	70
Section 5 Interrupt Controller.....		71
5.1	Features.....	71
5.2	Input/Output Pins.....	73
5.3	Register Descriptions.....	74
5.3.1	Interrupt Control Registers A to D (ICRA to ICRD).....	74
5.3.2	Address Break Control Register (ABRKCR)	75
5.3.3	Break Address Registers A to C (BARA to BARC).....	76
5.3.4	IRQ Sense Control Registers (ISCR16H, ISCR16L, ISCRH, ISCR L).....	77
5.3.5	IRQ Enable Registers (IER16, IER)	79
5.3.6	IRQ Status Registers (ISR16, ISR).....	80
5.3.7	Keyboard Matrix Interrupt Mask Registers (KMIMRA, KMIMR6) Wake-Up Event Interrupt Mask Register (WUEMR3).....	81
5.4	Interrupt Sources.....	82

5.4.1	External Interrupts	82
5.4.2	Internal Interrupts	84
5.5	Interrupt Exception Handling Vector Table.....	85
5.6	Interrupt Control Modes and Interrupt Operation	88
5.6.1	Interrupt Control Mode 0.....	90
5.6.2	Interrupt Control Mode 1	92
5.6.3	Interrupt Exception Handling Sequence	94
5.6.4	Interrupt Response Times	96
5.6.5	DTC Activation by Interrupt.....	97
5.7	Usage Notes	99
5.7.1	Conflict between Interrupt Generation and Disabling	99
5.7.2	Instructions that Disable Interrupts	100
5.7.3	Interrupts during Execution of EEPMOV Instruction.....	100
5.7.4	IRQ Status Registers (ISR16, ISR).....	100
Section 6 Bus Controller (BSC).....		101
6.1	Features.....	101
6.2	Input/Output Pins	104
6.3	Register Descriptions	105
6.3.1	Bus Control Register (BCR)	105
6.3.2	Bus Control Register 2 (BCR2)	106
6.3.3	Wait State Control Register (WSCR)	108
6.3.4	Wait State Control Register 2 (WSCR2)	110
6.4	Bus Control.....	112
6.4.1	Bus Specifications.....	112
6.4.2	Advanced Mode.....	122
6.4.3	I/O Select Signals.....	123
6.5	Bus Interface	124
6.5.1	Data Size and Data Alignment.....	124
6.5.2	Valid Strobes	126
6.5.3	Basic Operation Timing in Normal Extended Mode	127
6.5.4	Basic Operation Timing in Address-Data Multiplex Extended Mode	135
6.5.5	Wait Control	141
6.6	Burst ROM Interface.....	145
6.6.1	Basic Operation Timing.....	145
6.6.2	Wait Control	146
6.7	Idle Cycle.....	147
6.8	Bus Arbitration.....	148
6.8.1	Overview.....	148
6.8.2	Operation	148
6.8.3	Bus Mastership Transfer Timing	148

Section 7	Data Transfer Controller (DTC)	149
7.1	Features	149
7.2	Register Descriptions	151
7.2.1	DTC Mode Register A (MRA)	152
7.2.2	DTC Mode Register B (MRB)	153
7.2.3	DTC Source Address Register (SAR)	153
7.2.4	DTC Destination Address Register (DAR)	153
7.2.5	DTC Transfer Count Register A (CRA)	154
7.2.6	DTC Transfer Count Register B (CRB)	154
7.2.7	DTC Enable Registers (DTCER)	154
7.2.8	DTC Vector Register (DTVECR)	155
7.2.9	Keyboard Comparator Control Register (KBCOMP)	156
7.2.10	Event Counter Control Register (ECCR)	157
7.2.11	Event Counter Status Register (ECS)	158
7.3	DTC Event Counter	159
7.3.1	Event Counter Handling Priority	160
7.3.2	Usage Notes	161
7.4	Activation Sources	161
7.5	Location of Register Information and DTC Vector Table	162
7.6	Operation	165
7.6.1	Normal Mode	166
7.6.2	Repeat Mode	167
7.6.3	Block Transfer Mode	168
7.6.4	Chain Transfer	169
7.6.5	Interrupt Sources	170
7.6.6	Operation Timing	170
7.6.7	Number of DTC Execution States	171
7.7	Procedures for Using DTC	173
7.7.1	Activation by Interrupt	173
7.7.2	Activation by Software	173
7.8	Examples of Use of the DTC	174
7.8.1	Normal Mode	174
7.8.2	Software Activation	174
7.9	Usage Notes	176
7.9.1	Module Stop Mode Setting	176
7.9.2	On-Chip RAM	176
7.9.3	DTCE Bit Setting	176
7.9.4	Setting Required on Entering Subactive Mode or Watch Mode	176
7.9.5	DTC Activation by Interrupt Sources of SCI, IIC, or A/D Converter	176

Section 8	I/O Ports	177
8.1	Port 1	183
8.1.1	Port 1 Data Direction Register (P1DDR).....	183
8.1.2	Port 1 Data Register (P1DR).....	184
8.1.3	Port 1 Pull-Up MOS Control Register (P1PCR).....	184
8.1.4	Pin Functions	185
8.1.5	Port 1 Input Pull-Up MOS	186
8.2	Port 2	187
8.2.1	Port 2 Data Direction Register (P2DDR).....	187
8.2.2	Port 2 Data Register (P2DR).....	188
8.2.3	Port 2 Pull-Up MOS Control Register (P2PCR).....	188
8.2.4	Pin Functions	189
8.2.5	Port 2 Input Pull-Up MOS	190
8.3	Port 3	191
8.3.1	Port 3 Data Direction Register (P3DDR).....	191
8.3.2	Port 3 Data Register (P3DR).....	191
8.3.3	Port 3 Pull-Up MOS Control Register (P3PCR).....	192
8.3.4	Pin Functions	192
8.3.5	Port 3 Input Pull-Up MOS	195
8.4	Port 4	196
8.4.1	Port 4 Data Direction Register (P4DDR).....	196
8.4.2	Port 4 Data Register (P4DR).....	196
8.4.3	Pin Functions	197
8.5	Port 5	200
8.5.1	Port 5 Data Direction Register (P5DDR).....	200
8.5.2	Port 5 Data Register (P5DR).....	200
8.5.3	Pin Functions	201
8.6	Port 6	204
8.6.1	Port 6 Data Direction Register (P6DDR).....	204
8.6.2	Port 6 Data Register (P6DR).....	205
8.6.3	Port 6 Pull-Up MOS Control Register (KMPCR6).....	205
8.6.4	System Control Register 2 (SYSCR2)	206
8.6.5	Noise Canceler Enable Register (P6NCE).....	206
8.6.6	Noise Canceler Mode Control Register (P6NCCM).....	207
8.6.7	Noise Canceler Cycle Setting Register (P6NCCS).....	207
8.6.8	Pin Functions	209
8.6.9	Port 6 Input Pull-Up MOS	213
8.7	Port 7	213
8.7.1	Port 7 Input Data Register (P7PIN)	213
8.7.2	Pin Functions	214
8.8	Port 8	217
8.8.1	Port 8 Data Direction Register (P8DDR).....	217

8.8.2	Port 8 Data Register (P8DR)	217
8.8.3	Pin Functions	218
8.9	Port 9	222
8.9.1	Port 9 Data Direction Register (P9DDR)	222
8.9.2	Port 9 Data Register (P9DR)	223
8.9.3	Pin Functions	223
8.10	Port A	226
8.10.1	Port A Data Direction Register (PADDR)	226
8.10.2	Port A Output Data Register (PAODR)	227
8.10.3	Port A Input Data Register (PAPIN)	227
8.10.4	Pin Functions	228
8.10.5	Input Pull-Up MOS	231
8.11	Port B	232
8.11.1	Port B Data Direction Register (PBDDR)	232
8.11.2	Port B Output Data Register (PBODR)	232
8.11.3	Port B Input Data Register (PBPIN)	233
8.11.4	Pin Functions	233
8.12	Port C	235
8.12.1	Port C Data Direction Register (PCDDR)	235
8.12.2	Port C Output Data Register (PCODR)	235
8.12.3	Port C Input Data Register (PCPIN)	236
8.12.4	Pin Functions	236
8.13	Port D	238
8.13.1	Port D Data Direction Register (PDDDR)	238
8.13.2	Port D Output Data Register (PDODR)	239
8.13.3	Port D Input Data Register (PDPIN)	239
8.13.4	Pin Functions	240
8.13.5	Input Pull-Up MOS	242
8.14	Port E	243
8.14.1	Port E Data Direction Register (PEDDR)	243
8.14.2	Port E Output Data Register (PEODR)	243
8.14.3	Port E Input Data Register (PEPIN)	244
8.14.4	Pin Functions	244
8.15	Port F	246
8.15.1	Port F Data Direction Register (PFDDR)	246
8.15.2	Port F Output Data Register (PFODR)	246
8.15.3	Port F Input Data Register (PFPIN)	247
8.15.4	Pin Functions	247
8.16	Change of Peripheral Function Pins	248
8.16.1	IRQ Sense Port Select Register 16 (ISSR16), IRQ Sense Port Select Register (ISSR)	248
8.16.2	Port Control Register 0 (PTCNT0)	250

Section 9	8-Bit PWM Timer (PWM)	251
9.1	Features	251
9.2	Input/Output Pins	252
9.3	Register Descriptions	252
9.3.1	PWM Register Select (PWSL)	253
9.3.2	PWM Data Registers 15 to 0 (PWDR15 to PWDR0)	255
9.3.3	PWM Data Polarity Registers A and B (PWPRA and PWPBR)	255
9.3.4	PWM Output Enable Registers A and B (PWOERA and PWOERB)	256
9.3.5	Peripheral Clock Select Register (PCSR)	257
9.4	Operation	258
9.4.1	PWM Setting Example	260
9.4.2	Diagram of PWM Used as D/A Converter	260
Section 10	14-Bit PWM Timer (PWMX)	261
10.1	Features	261
10.2	Input/Output Pins	262
10.3	Register Descriptions	262
10.3.1	PWMX (D/A) Counter (DACNT)	263
10.3.2	PWMX (D/A) Data Registers A and B (DADRA and DADR)	264
10.3.3	PWMX (D/A) Control Register (DACR)	266
10.3.4	Peripheral Clock Select Register (PCSR)	267
10.4	Bus Master Interface	268
10.5	Operation	269
Section 11	16-Bit Free-Running Timer (FRT)	277
11.1	Features	277
11.2	Input/Output Pins	279
11.3	Register Descriptions	279
11.3.1	Free-Running Counter (FRC)	280
11.3.2	Output Compare Registers A and B (OCRA and OCRB)	280
11.3.3	Input Capture Registers A to D (ICRA to ICRD)	280
11.3.4	Output Compare Registers AR and AF (OCRAR and OCRAF)	281
11.3.5	Output Compare Register DM (OCRDM)	281
11.3.6	Timer Interrupt Enable Register (TIER)	282
11.3.7	Timer Control/Status Register (TCSR)	283
11.3.8	Timer Control Register (TCR)	286
11.3.9	Timer Output Compare Control Register (TOCR)	287
11.4	Operation	289
11.4.1	Pulse Output	289
11.5	Operation Timing	290
11.5.1	FRC Increment Timing	290
11.5.2	Output Compare Output Timing	291
11.5.3	FRC Clear Timing	291

11.5.4	Input Capture Input Timing	292
11.5.5	Buffered Input Capture Input Timing	293
11.5.6	Timing of Input Capture Flag (ICF) Setting	294
11.5.7	Timing of Output Compare Flag (OCF) setting.....	295
11.5.8	Timing of FRC Overflow Flag (OVF) Setting.....	295
11.5.9	Automatic Addition Timing.....	296
11.5.10	Mask Signal Generation Timing.....	296
11.6	Interrupt Sources.....	298
11.7	Usage Notes.....	299
11.7.1	Conflict between FRC Write and Clear	299
11.7.2	Conflict between FRC Write and Increment.....	300
11.7.3	Conflict between OCR Write and Compare-Match	301
11.7.4	Switching of Internal Clock and FRC Operation.....	302
Section 12	8-Bit Timer (TMR).....	305
12.1	Features.....	305
12.2	Input/Output Pins.....	308
12.3	Register Descriptions.....	309
12.3.1	Timer Counter (TCNT).....	309
12.3.2	Time Constant Register A (TCORA)	310
12.3.3	Time Constant Register B (TCORB).....	310
12.3.4	Timer Control Register (TCR).....	311
12.3.5	Timer Control/Status Register (TCSR).....	314
12.3.6	Input Capture Register (TICR)	319
12.3.7	Time Constant Register C (TCORC).....	319
12.3.8	Input Capture Registers R and F (TICRR and TICRF).....	319
12.3.9	Timer Input Select Register (TISR).....	320
12.3.10	Timer Connection Register I (TCONRI)	320
12.3.11	Timer Connection Register S (TCONRS)	321
12.4	Operation	322
12.4.1	Pulse Output	322
12.5	Operation Timing.....	323
12.5.1	TCNT Count Timing	323
12.5.2	Timing of CMFA and CMFB Setting at Compare-Match	323
12.5.3	Timing of Timer Output at Compare-Match.....	324
12.5.4	Timing of Counter Clear at Compare-Match.....	324
12.5.5	TCNT External Reset Timing.....	325
12.5.6	Timing of Overflow Flag (OVF) Setting	325
12.6	TMR_0 and TMR_1 Cascaded Connection.....	326
12.6.1	16-Bit Count Mode	326
12.6.2	Compare-Match Count Mode	326
12.7	Input Capture Operation	327
12.8	Interrupt Sources.....	329

12.9	Usage Notes	330
12.9.1	Conflict between TCNT Write and Counter Clear.....	330
12.9.2	Conflict between TCNT Write and Increment.....	331
12.9.3	Conflict between TCOR Write and Compare-Match.....	332
12.9.4	Conflict between Compare-Matches A and B	333
12.9.5	Switching of Internal Clocks and TCNT Operation.....	333
12.9.6	Mode Setting with Cascaded Connection	335
Section 13 Watchdog Timer (WDT).....		337
13.1	Features.....	337
13.2	Input/Output Pins	339
13.3	Register Descriptions	340
13.3.1	Timer Counter (TCNT).....	340
13.3.2	Timer Control/Status Register (TCSR).....	340
13.4	Operation	344
13.4.1	Watchdog Timer Mode	344
13.4.2	Interval Timer Mode.....	345
13.4.3	$\overline{\text{RESO}}$ Signal Output Timing	346
13.5	Interrupt Sources.....	347
13.6	Usage Notes	348
13.6.1	Notes on Register Access.....	348
13.6.2	Conflict between Timer Counter (TCNT) Write and Increment.....	349
13.6.3	Changing Values of CKS2 to CKS0 Bits.....	349
13.6.4	Changing Value of PSS Bit.....	349
13.6.5	Switching between $\overline{\text{RESO}}$ Watchdog Timer Mode and Interval Timer Mode.....	350
13.6.6	System Reset by $\overline{\text{RESO}}$ Signal	350
Section 14 Serial Communication Interface (SCI, IrDA, and CRC)		351
14.1	Features.....	351
14.2	Input/Output Pins	355
14.3	Register Descriptions	356
14.3.1	Receive Shift Register (RSR)	356
14.3.2	Receive Data Register (RDR).....	356
14.3.3	Transmit Data Register (TDR).....	357
14.3.4	Transmit Shift Register (TSR).....	357
14.3.5	Serial Mode Register (SMR)	357
14.3.6	Serial Control Register (SCR)	361
14.3.7	Serial Status Register (SSR)	364
14.3.8	Smart Card Mode Register (SCMR).....	368
14.3.9	Bit Rate Register (BRR)	369
14.3.10	Serial Interface Control Register (SCICR)	375
14.3.11	Serial Enhanced Mode Register_0 and 2 (SEMR_0 and SEMR_2)	376
14.4	Operation in Asynchronous Mode	380

14.4.1	Data Transfer Format.....	381
14.4.2	Receive Data Sampling Timing and Reception Margin in Asynchronous Mode	382
14.4.3	Clock.....	383
14.4.4	Serial Enhanced Mode Clock	383
14.4.5	SCI Initialization (Asynchronous Mode).....	386
14.4.6	Serial Data Transmission (Asynchronous Mode)	387
14.4.7	Serial Data Reception (Asynchronous Mode)	389
14.5	Multiprocessor Communication Function.....	393
14.5.1	Multiprocessor Serial Data Transmission	395
14.5.2	Multiprocessor Serial Data Reception	396
14.6	Operation in Clock Synchronous Mode.....	399
14.6.1	Clock.....	399
14.6.2	SCI Initialization (Clock Synchronous Mode).....	400
14.6.3	Serial Data Transmission (Clock Synchronous Mode).....	401
14.6.4	Serial Data Reception (Clock Synchronous Mode)	403
14.6.5	Simultaneous Serial Data Transmission and Reception (Clock Synchronous Mode).....	405
14.6.6	SCI Selection in Serial Enhanced Mode	405
14.7	Smart Card Interface Description	407
14.7.1	Sample Connection.....	407
14.7.2	Data Format (Except in Block Transfer Mode)	407
14.7.3	Block Transfer Mode	409
14.7.4	Receive Data Sampling Timing and Reception Margin	409
14.7.5	Initialization	410
14.7.6	Serial Data Transmission (Except in Block Transfer Mode)	411
14.7.7	Serial Data Reception (Except in Block Transfer Mode)	414
14.7.8	Clock Output Control.....	415
14.8	IrDA Operation	417
14.9	Interrupt Sources.....	420
14.9.1	Interrupts in Normal Serial Communication Interface Mode	420
14.9.2	Interrupts in Smart Card Interface Mode	421
14.10	Usage Notes	422
14.10.1	Module Stop Mode Setting	422
14.10.2	Break Detection and Processing	422
14.10.3	Mark State and Break Sending	422
14.10.4	Receive Error Flags and Transmit Operations (Clock Synchronous Mode Only)	422
14.10.5	Relation between Writing to TDR and TDRE Flag	422
14.10.6	Restrictions on Using DTC.....	423
14.10.7	SCI Operations during Mode Transitions	423
14.10.8	Notes on Switching from SCK Pins to Port Pins	427
14.11	CRC Operation Circuit	428

14.11.1	Features	428
14.11.2	Register Descriptions	428
14.11.3	CRC Operation Circuit Operation	430
14.11.4	Note on CRC Operation Circuit	433
Section 15 I²C Bus Interface (IIC)		435
15.1	Features	435
15.2	Input/Output Pins	438
15.3	Register Descriptions	439
15.3.1	I ² C Bus Data Register (ICDR)	439
15.3.2	Slave Address Register (SAR)	440
15.3.3	Second Slave Address Register (SARX)	441
15.3.4	I ² C Bus Mode Register (ICMR)	442
15.3.5	I ² C Bus Transfer Rate Select Register (IICX3)	443
15.3.6	I ² C Bus Control Register (ICCR)	446
15.3.7	I ² C Bus Status Register (ICSR)	455
15.3.8	I ² C Bus Extended Control Register (ICXR)	459
15.3.9	I ² C SMBus Control Register (ICSMBCR)	463
15.4	Operation	465
15.4.1	I ² C Bus Data Format	465
15.4.2	Initialization	467
15.4.3	Master Transmit Operation	467
15.4.4	Master Receive Operation	471
15.4.5	Slave Receive Operation	478
15.4.6	Slave Transmit Operation	485
15.4.7	IRIC Setting Timing and SCL Control	488
15.4.8	Operation Using the DTC	490
15.4.9	Noise Canceler	492
15.4.10	Initialization of Internal State	492
15.5	Interrupt Source	494
15.6	Usage Notes	495
Section 16 LPC Interface (LPC)		507
16.1	Features	507
16.2	Input/Output Pins	509
16.3	Register Descriptions	510
16.3.1	Host Interface Control Registers 0 and 1 (HICR0, HICR1)	512
16.3.2	Host Interface Control Registers 2 and 3 (HICR2, HICR3)	518
16.3.3	Host Interface Control Register 4 (HICR4)	521
16.3.4	LPC Channel 3 Address Register H, L (LADR3H, LADR3L)	522
16.3.5	LPC Channel 1, 2 Address Register H, L (LADR12H, LADR12L)	526
16.3.6	Input Data Registers 1 to 3 (IDR1 to IDR3)	527
16.3.7	Output Data Registers 0 to 3 (ODR1 to ODR3)	527

16.3.8	Bidirectional Data Registers 0 to 15 (TWR0 to TWR15)	528
16.3.9	Status Registers 1 to 3 (STR1 to STR3)	529
16.3.10	SERIRQ Control Register 0 (SIRQCR0)	536
16.3.11	SERIRQ Control Register 1 (SIRQCR1)	539
16.3.12	SERIRQ Control Register 2 (SIRQCR2)	544
16.3.13	Host Interface Select Register (HISEL)	545
16.3.14	SMIC Flag Register (SMICFLG)	546
16.3.15	SMIC Control Status Register (SMICCSR)	548
16.3.16	SMIC Data Register (SMICDTR)	548
16.3.17	SMIC Interrupt Register 0 (SMICIR0)	548
16.3.18	SMIC Interrupt Register 1 (SMICIR1)	551
16.3.19	BT Status Register 0 (BTSR0)	552
16.3.20	BT Status Register 1 (BTSR1)	554
16.3.21	BT Control Status Register 0 (BTCSR0)	557
16.3.22	BT Control Status Register 1 (BTCSR1)	558
16.3.23	BT Control Register (BTCR)	560
16.3.24	BT Data Buffer (BTDTR)	563
16.3.25	BT Interrupt Mask Register (BTIMSR)	564
16.3.26	BT FIFO Valid Size Register 0 (BTFVSR0)	566
16.3.27	BT FIFO Valid Size Register 1 (BTFVSR1)	566
16.4	Operation	567
16.4.1	LPC Interface Activation	567
16.4.2	LPC I/O Cycles	567
16.4.3	SMIC Mode Transfer Flow	569
16.4.4	BT Mode Transfer Flow	572
16.4.5	A20 Gate	574
16.4.6	LPC Interface Shutdown Function (LPCPD)	577
16.4.7	LPC Interface Serialized Interrupt Operation (SERIRQ)	581
16.4.8	LPC Interface Clock Start Request	583
16.5	Interrupt Sources	584
16.5.1	IBFI1, IBFI2, IBFI3, ERRI	584
16.5.2	SMI, HIRQ1, HIRQ6, HIRQ9, HIRQ10, HIRQ11, HIRQ12	584
16.6	Usage Notes	587
16.6.1	Module Stop Setting	587
16.6.2	Usage Note of LPC Interface	587
Section 17	D/A Converter	589
17.1	Features	589
17.2	Input/Output Pins	590
17.3	Register Descriptions	591
17.3.1	D/A Data Registers 0 and 1 (DADR0, DADR1)	591
17.3.2	D/A Control Register (DACR)	591
17.4	Operation	593

17.5	Usage Note.....	594
Section 18	A/D Converter.....	595
18.1	Features.....	595
18.1.1	Block Diagram.....	596
18.2	Input/Output Pins.....	597
18.3	Register Descriptions.....	598
18.3.1	A/D Data Registers A to D (ADDRA to ADDR D).....	598
18.3.2	A/D Control/Status Register (ADCSR).....	599
18.3.3	A/D Control Register (ADCR).....	600
18.4	Operation.....	601
18.4.1	Single Mode.....	601
18.4.2	Scan Mode.....	601
18.4.3	Input Sampling and A/D Conversion Time.....	602
18.4.4	External Trigger Input Timing.....	603
18.5	Interrupt Source.....	604
18.6	A/D Conversion Accuracy Definitions.....	604
18.7	Usage Notes.....	606
18.7.1	Permissible Signal Source Impedance.....	606
18.7.2	Influences on Absolute Accuracy.....	606
18.7.3	Setting Range of Analog Power Supply and Other Pins.....	607
18.7.4	Notes on Board Design.....	607
18.7.5	Notes on Noise Countermeasures.....	607
Section 19	RAM.....	609
Section 20	Flash Memory (0.18- μ m F-ZTAT Version).....	611
20.1	Features.....	611
20.1.1	Operating Mode.....	613
20.1.2	Mode Comparison.....	614
20.1.3	Flash Memory MAT Configuration.....	615
20.1.4	Block Division.....	616
20.1.5	Programming/Erasing Interface.....	618
20.2	Input/Output Pins.....	620
20.3	Register Descriptions.....	620
20.3.1	Programming/Erasing Interface Register.....	621
20.3.2	Programming/Erasing Interface Parameter.....	628
20.4	On-Board Programming Mode.....	638
20.4.1	Boot Mode.....	638
20.4.2	User Program Mode.....	642
20.4.3	User Boot Mode.....	652
20.4.4	Procedure Program and Storable Area for Programming Data.....	655
20.5	Protection.....	665

20.5.1	Hardware Protection	665
20.5.2	Software Protection	666
20.5.3	Error Protection	666
20.6	Switching between User MAT and User Boot MAT.....	668
20.7	Programmer Mode.....	669
20.8	Serial Communication Interface Specification for Boot Mode.....	670
20.9	Usage Notes.....	695
Section 21 Boundary Scan (JTAG)		697
21.1	Features.....	697
21.2	Input/Output Pins.....	699
21.3	Register Descriptions.....	700
21.3.1	Instruction Register (SDIR).....	701
21.3.2	Bypass Register (SDBPR)	703
21.3.3	Boundary Scan Register (SDBSR)	703
21.3.4	ID Code Register (SDIDR).....	713
21.4	Operation	714
21.4.1	TAP Controller State Transitions.....	714
21.4.2	JTAG Reset.....	715
21.5	Boundary Scan.....	715
21.5.1	Supported Instructions	715
21.6	Usage Notes.....	718
Section 22 Clock Pulse Generator.....		721
22.1	Oscillator.....	722
22.1.1	Connecting Crystal Resonator	722
22.1.2	External Clock Input Method	723
22.2	PLL Multiplier Circuit	724
22.3	Medium-Speed Clock Divider	724
22.4	Bus Master Clock Select Circuit.....	724
22.5	Subclock Input Circuit	724
22.6	Subclock Waveform Forming Circuit.....	724
22.7	Clock Select Circuit	725
22.8	Usage Notes	725
22.8.1	Note on Resonator	725
22.8.2	Notes on Board Design	725
22.8.3	Note on Operation Check	726
Section 23 Power-Down Modes.....		727
23.1	Register Descriptions.....	728
23.1.1	Standby Control Register (SBYCR).....	728
23.1.2	Low-Power Control Register (LPWRCR).....	730

23.1.3	Module Stop Control Registers H, L, and A (MSTPCRH, MSTPCRL, MSTPCRA)	732
23.1.4	Sub-Chip Module Stop Control Registers BH, BL (SUBMSTPBH, SUBMSTPBL)	734
23.1.5	Sub-Chip Module Stop Control Registers AH, AL (SUBMSTPAH, SUBMSTPAL)	734
23.2	Mode Transitions and LSI States	735
23.3	Medium-Speed Mode.....	739
23.4	Sleep Mode	740
23.5	Software Standby Mode.....	741
23.6	Hardware Standby Mode	743
23.7	Watch Mode.....	744
23.8	Subsleep Mode.....	745
23.9	Subactive Mode	746
23.10	Module Stop Mode	747
23.11	Direct Transitions.....	747
23.12	Usage Notes	748
	23.12.1 I/O Port Status.....	748
	23.12.2 Current Consumption when Waiting for Oscillation Settling	748
	23.12.3 DTC Module Stop Mode	748
	23.12.4 Notes on Subclock Usage	748
Section 24 List of Registers		749
24.1	Register Addresses (Address Order).....	749
24.2	Register Bits.....	762
24.3	Register States in Each Operating Mode	773
Section 25 Electrical Characteristics		783
25.1	Absolute Maximum Ratings	783
25.2	DC Characteristics	784
25.3	AC Characteristics	788
	25.3.1 Clock Timing	788
	25.3.2 Control Signal Timing	792
	25.3.3 Bus Timing	794
	25.3.4 Multiplex Bus Timing.....	800
	25.3.5 Timing of On-Chip Peripheral Modules	802
25.4	A/D Conversion Characteristics.....	811
25.5	D/A Conversion Characteristics.....	812
25.6	Flash Memory Characteristics	813
25.7	Usage Notes	816

Appendix	817
A. I/O Port States in Each Pin State.....	817
B. Product Lineup.....	819
C. Package Dimensions	820
Main Revisions and Additions in this Edition.....	821
Index	825

Figures

Section 1 Overview

Figure 1.1 Internal Block Diagram	2
Figure 1.2 Pin Arrangement (TFP-144).....	3

Section 2 CPU

Figure 2.1 Exception Vector Table (Normal Mode).....	19
Figure 2.2 Stack Structure in Normal Mode.....	19
Figure 2.3 Exception Vector Table (Advanced Mode).....	20
Figure 2.4 Stack Structure in Advanced Mode.....	21
Figure 2.5 Memory Map.....	22
Figure 2.6 CPU Internal Registers.....	23
Figure 2.7 Usage of General Registers.....	24
Figure 2.8 Stack.....	25
Figure 2.9 General Register Data Formats (1).....	28
Figure 2.9 General Register Data Formats (2).....	29
Figure 2.10 Memory Data Formats.....	30
Figure 2.11 Instruction Formats (Examples).....	42
Figure 2.12 Branch Address Specification in Memory Indirect Addressing Mode.....	46
Figure 2.13 State Transitions.....	50

Section 3 MCU Operating Modes

Figure 3.1 H8S/2168 Address Map	60
Figure 3.2 H8S/2167 Address Map	61
Figure 3.3 H8S/2166 Address Map	62

Section 4 Exception Handling

Figure 4.1 Reset Sequence.....	67
Figure 4.2 Stack Status after Exception Handling.....	69
Figure 4.3 Operation when SP Value Is Odd.....	70

Section 5 Interrupt Controller

Figure 5.1 Block Diagram of Interrupt Controller.....	72
Figure 5.2 Block Diagram of Interrupts IRQ15 to IRQ0.....	82
Figure 5.3 Block Diagram of Interrupts KIN15 to KIN0 and WUE15 to WUE8 (Example of KIN15 to KIN0).....	83
Figure 5.4 Block Diagram of Interrupt Control Operation	88
Figure 5.5 Flowchart of Procedure up to Interrupt Acceptance in Interrupt Control Mode 0.....	91
Figure 5.6 State Transition in Interrupt Control Mode 1	92
Figure 5.7 Flowchart of Procedure Up to Interrupt Acceptance in Interrupt Control Mode 1.....	94
Figure 5.8 Interrupt Exception Handling.....	95
Figure 5.9 Interrupt Control for DTC.....	97
Figure 5.10 Conflict between Interrupt Generation and Disabling.....	99

Section 6 Bus Controller (BSC)

Figure 6.1	Block Diagram of Bus Controller.....	103
Figure 6.2	$\overline{\text{IOS}}$ Signal Output Timing	123
Figure 6.3	Access Sizes and Data Alignment Control (8-bit Access Space).....	124
Figure 6.4	Access Sizes and Data Alignment Control (16-bit Access Space).....	125
Figure 6.5	Bus Timing for 8-Bit, 2-State Access Space	127
Figure 6.6	Bus Timing for 8-Bit, 3-State Access Space	128
Figure 6.7	Bus Timing for 16-Bit, 2-State Access Space (Even Byte Access).....	129
Figure 6.8	Bus Timing for 16-Bit, 2-State Access Space (Odd Byte Access).....	130
Figure 6.9	Bus Timing for 16-Bit, 2-State Access Space (Word Access).....	131
Figure 6.10	Bus Timing for 16-Bit, 3-State Access Space (Even Byte Access).....	132
Figure 6.11	Bus Timing for 16-Bit, 3-State Access Space (Odd Byte Access).....	133
Figure 6.12	Bus Timing for 16-Bit, 3-State Access Space (Word Access)	134
Figure 6.13	Bus Timing for 8-Bit, 2-State Access Space	135
Figure 6.14	Bus Timing for 8-Bit, 2-State Access Space	135
Figure 6.15	Bus Timing for 8-Bit, 3-State Access Space	136
Figure 6.16	Bus Timing for 16-Bit, 2-State Access Space (1) (Even Byte Access).....	137
Figure 6.17	Bus Timing for 16-Bit, 2-State Access Space (2) (Even Byte Access).....	137
Figure 6.18	Bus Timing for 16-Bit, 2-State Access Space (3) (Odd Byte Access)	138
Figure 6.19	Bus Timing for 16-Bit, 2-State Access Space (4) (Odd Byte Access)	138
Figure 6.20	Bus Timing for 16-Bit, 2-State Access Space (5) (Word Access).....	139
Figure 6.21	Bus Timing for 16-Bit, 2-State Access Space (6) (Word Access).....	139
Figure 6.22	Bus Timing for 16-Bit, 3-State Access Space (1) (Even Byte Access).....	140
Figure 6.23	Bus Timing for 16-Bit, 3-State Access Space (2) (Odd Byte Access)	140
Figure 6.24	Bus Timing for 16-Bit, 3-State Access Space (3) (Word Access).....	141
Figure 6.25	Example of Wait State Insertion Timing (Pin Wait Mode).....	142
Figure 6.26	Example of Wait State Insertion Timing.....	144
Figure 6.27	Access Timing Example in Burst ROM Space (AST = BRSTS1 = 1).....	145
Figure 6.28	Access Timing Example in Burst ROM Space (AST = BRSTS1 = 0).....	146
Figure 6.29	Examples of Idle Cycle Operation	147

Section 7 Data Transfer Controller (DTC)

Figure 7.1	Block Diagram of DTC	150
Figure 7.2	Block Diagram of DTC Activation Source Control	161
Figure 7.3	DTC Register Information Location in Address Space.....	162
Figure 7.4	DTC Operation Flowchart.....	165
Figure 7.5	Memory Mapping in Normal Mode	166
Figure 7.6	Memory Mapping in Repeat Mode	167
Figure 7.7	Memory Mapping in Block Transfer Mode	168
Figure 7.8	Chain Transfer Operation.....	169
Figure 7.9	DTC Operation Timing (Example in Normal Mode or Repeat Mode)	170
Figure 7.10	DTC Operation Timing (Example of Block Transfer Mode, with Block Size of 2).....	171

Figure 7.11 DTC Operation Timing (Example of Chain Transfer)	171
--	-----

Section 8 I/O Ports

Figure 8.1 Noise Canceler Circuit	208
Figure 8.2 Noise Canceler Operation.....	208

Section 9 8-Bit PWM Timer (PWM)

Figure 9.1 Block Diagram of PWM Timer.....	251
Figure 9.2 Example of Additional Pulse Timing (When Upper 4 Bits of PWDR = B'1000)	259
Figure 9.3 Example of PWM Setting.....	260
Figure 9.4 Example when PWM is Used as D/A Converter.....	260

Section 10 14-Bit PWM Timer (PWMX)

Figure 10.1 PWMX (D/A) Block Diagram.....	261
Figure 10.2 PWMX (D/A) Operation	269
Figure 10.3 Output Waveform (OS = 0, DADR corresponds to T_L)	272
Figure 10.4 Output Waveform (OS = 1, DADR corresponds to T_H).....	273
Figure 10.5 D/A Data Register Configuration when CFS = 1	273
Figure 10.6 Output Waveform when DADR = H'0207 (OS = 1)	274

Section 11 16-Bit Free-Running Timer (FRT)

Figure 11.1 Block Diagram of 16-Bit Free-Running Timer	278
Figure 11.2 Example of Pulse Output.....	289
Figure 11.3 Increment Timing with Internal Clock Source	290
Figure 11.4 Increment Timing with External Clock Source	290
Figure 11.5 Timing of Output Compare A Output	291
Figure 11.6 Clearing of FRC by Compare-Match A Signal	291
Figure 11.7 Input Capture Input Signal Timing (Usual Case).....	292
Figure 11.8 Input Capture Input Signal Timing (When ICRA to ICRD is Read).....	292
Figure 11.9 Buffered Input Capture Timing.....	293
Figure 11.10 Buffered Input Capture Timing (BUFEA = 1).....	294
Figure 11.11 Timing of Input Capture Flag (ICFA to ICFD) Setting.....	294
Figure 11.12 Timing of Output Compare Flag (OCFA or OCFB) Setting	295
Figure 11.13 Timing of Overflow Flag (OVF) Setting.....	295
Figure 11.14 OCRA Automatic Addition Timing	296
Figure 11.15 Timing of Input Capture Mask Signal Setting.....	296
Figure 11.16 Timing of Input Capture Mask Signal Clearing	297
Figure 11.17 Conflict between FRC Write and Clear.....	299
Figure 11.18 Conflict between FRC Write and Increment	300
Figure 11.19 Conflict between OCR Write and Compare-Match (When Automatic Addition Function is Not Used).....	301
Figure 11.20 Conflict between OCR Write and Compare-Match (When Automatic Addition Function is Used).....	302

Section 12 8-Bit Timer (TMR)

Figure 12.1	Block Diagram of 8-Bit Timer (TMR_0 and TMR_1).....	306
Figure 12.2	Block Diagram of 8-Bit Timer (TMR_Y and TMR_X).....	307
Figure 12.3	Pulse Output Example.....	322
Figure 12.4	Count Timing for Internal Clock Input	323
Figure 12.5	Count Timing for External Clock Input	323
Figure 12.6	Timing of CMF Setting at Compare-Match	324
Figure 12.7	Timing of Toggled Timer Output by Compare-Match A Signal.....	324
Figure 12.8	Timing of Counter Clear by Compare-Match	324
Figure 12.9	Timing of Counter Clear by External Reset Input.....	325
Figure 12.10	Timing of OVF Flag Setting	325
Figure 12.11	Timing of Input Capture Operation.....	327
Figure 12.12	Timing of Input Capture Signal (Input capture signal is input during TICRR and TICRF read)	328
Figure 12.13	Conflict between TCNT Write and Counter Clear.....	330
Figure 12.14	Conflict between TCNT Write and Increment	331
Figure 12.15	Conflict between TCOR Write and Compare-Match	332

Section 13 Watchdog Timer (WDT)

Figure 13.1	Block Diagram of WDT	338
Figure 13.2	Watchdog Timer Mode ($\overline{\text{RST}}/\overline{\text{NMI}} = 1$) Operation.....	344
Figure 13.3	Interval Timer Mode Operation.....	345
Figure 13.4	OVF Flag Set Timing.....	345
Figure 13.5	Output Timing of $\overline{\text{RESO}}$ signal.....	346
Figure 13.6	Writing to TCNT and TCSR (WDT_0).....	348
Figure 13.7	Conflict between TCNT Write and Increment	349
Figure 13.8	Sample Circuit for Resetting the System by the $\overline{\text{RESO}}$ Signal.....	350

Section 14 Serial Communication Interface (SCI, IrDA, and CRC)

Figure 14.1	Block Diagram of SCI_1	353
Figure 14.2	Block Diagram of SCI_0 and SCI_2.....	354
Figure 14.3	Data Format in Asynchronous Communication (Example with 8-Bit Data, Parity, Two Stop Bits).....	380
Figure 14.4	Receive Data Sampling Timing in Asynchronous Mode	382
Figure 14.5	Relation between Output Clock and Transmit Data Phase (Asynchronous Mode).....	383
Figure 14.6	Basic Clock Examples When Average Transfer Rate is Selected (1)	384
Figure 14.7	Basic Clock Examples When Average Transfer Rate is Selected (2)	385
Figure 14.8	Sample SCI Initialization Flowchart	386
Figure 14.9	Example of Operation in Transmission in Asynchronous Mode (Example with 8-Bit Data, Parity, One Stop Bit).....	387
Figure 14.10	Sample Serial Transmission Flowchart.....	388

Figure 14.11	Example of SCI Operation in Reception (Example with 8-Bit Data, Parity, One Stop Bit).....	389
Figure 14.12	Sample Serial Reception Flowchart (1).....	391
Figure 14.12	Sample Serial Reception Flowchart (2).....	392
Figure 14.13	Example of Communication Using Multiprocessor Format (Transmission of Data H'AA to Receiving Station A).....	394
Figure 14.14	Sample Multiprocessor Serial Transmission Flowchart	395
Figure 14.15	Example of SCI Operation in Reception (Example with 8-Bit Data, Multiprocessor Bit, One Stop Bit)	396
Figure 14.16	Sample Multiprocessor Serial Reception Flowchart (1).....	397
Figure 14.16	Sample Multiprocessor Serial Reception Flowchart (2).....	398
Figure 14.17	Data Format in Synchronous Communication (LSB-First).....	399
Figure 14.18	Sample SCI Initialization Flowchart	400
Figure 14.19	Sample SCI Transmission Operation in Clock Synchronous Mode.....	401
Figure 14.20	Sample Serial Transmission Flowchart	402
Figure 14.21	Example of SCI Receive Operation in Clock Synchronous Mode.....	403
Figure 14.22	Sample Serial Reception Flowchart	404
Figure 14.23	Sample Flowchart of Simultaneous Serial Transmission and Reception	406
Figure 14.24	Pin Connection for Smart Card Interface	407
Figure 14.25	Data Formats in Normal Smart Card Interface Mode.....	408
Figure 14.26	Direct Convention (SDIR = SINV = O/\bar{E} = 0).....	408
Figure 14.27	Inverse Convention (SDIR = SINV = O/\bar{E} = 1).....	408
Figure 14.28	Receive Data Sampling Timing in Smart Card Interface Mode (When Clock Frequency is 372 Times the Bit Rate)	410
Figure 14.29	Data Re-transfer Operation in SCI Transmission Mode.....	412
Figure 14.30	TEND Flag Set Timings during Transmission	412
Figure 14.31	Sample Transmission Flowchart	413
Figure 14.32	Data Re-transfer Operation in SCI Reception Mode	414
Figure 14.33	Sample Reception Flowchart.....	415
Figure 14.34	Clock Output Fixing Timing	415
Figure 14.35	Clock Stop and Restart Procedure.....	416
Figure 14.36	IrDA Block Diagram	417
Figure 14.37	IrDA Transmission and Reception	418
Figure 14.38	Sample Transmission using DTC in Clock Synchronous Mode	423
Figure 14.39	Sample Flowchart for Mode Transition during Transmission.....	424
Figure 14.40	Pin States during Transmission in Asynchronous Mode (Internal Clock).....	425
Figure 14.41	Pin States during Transmission in Clock Synchronous Mode (Internal Clock).....	425
Figure 14.42	Sample Flowchart for Mode Transition during Reception	426
Figure 14.43	Switching from SCK Pins to Port Pins.....	427
Figure 14.44	Prevention of Low Pulse Output at Switching from SCK Pins to Port Pins.....	427
Figure 14.45	Block Diagram of CRC Operation Circuit	428
Figure 14.46	LSB-First Data Transmission	430

Figure 14.47	MSB-First Data Transmission.....	430
Figure 14.48	LSB-First Data Reception.....	431
Figure 14.49	MSB-First Data Reception.....	432
Figure 14.50	LSB-First and MSB-First Transmit Data.....	433

Section 15 I²C Bus Interface (IIC)

Figure 15.1	Block Diagram of I ² C Bus Interface.....	436
Figure 15.2	I ² C Bus Interface Connections (Example: This LSI as Master).....	437
Figure 15.3	I ² C Bus Data Formats (I ² C Bus Formats).....	465
Figure 15.4	I ² C Bus Data Formats (Serial Formats).....	465
Figure 15.5	I ² C Bus Timing.....	466
Figure 15.6	Sample Flowchart for IIC Initialization.....	467
Figure 15.7	Sample Flowchart for Operations in Master Transmit Mode.....	468
Figure 15.8	Operation Timing Example in Master Transmit Mode (MLS = WAIT = 0).....	470
Figure 15.9	Stop Condition Issuance Operation Timing Example in Master Transmit Mode (MLS = WAIT = 0).....	470
Figure 15.10	Sample Flowchart for Operations in Master Receive Mode (HNDS = 1).....	471
Figure 15.11	Master Receive Mode Operation Timing Example (MLS = WAIT = 0, HNDS = 1).....	473
Figure 15.12	Stop Condition Issuance Timing Example in Master Receive Mode (MLS = WAIT = 0, HNDS = 1).....	473
Figure 15.13	Sample Flowchart for Operations in Master Receive Mode (receiving multiple bytes) (WAIT = 1).....	474
Figure 15.14	Sample Flowchart for Operations in Master Receive Mode (receiving a single byte) (WAIT = 1).....	475
Figure 15.15	Master Receive Mode Operation Timing Example (MLS = ACKB = 0, WAIT = 1).....	477
Figure 15.16	Stop Condition Issuance Timing Example in Master Receive Mode (MLS = ACKB = 0, WAIT = 1).....	478
Figure 15.17	Sample Flowchart for Operations in Slave Receive Mode (HNDS = 1).....	479
Figure 15.18	Slave Receive Mode Operation Timing Example (1) (MLS = 0, HNDS= 1).....	481
Figure 15.19	Slave Receive Mode Operation Timing Example (2) (MLS = 0, HNDS= 1).....	481
Figure 15.20	Sample Flowchart for Operations in Slave Receive Mode (HNDS = 0).....	482
Figure 15.21	Slave Receive Mode Operation Timing Example (1) (MLS = ACKB = 0, HNDS = 0).....	484
Figure 15.22	Slave Receive Mode Operation Timing Example (2) (MLS = ACKB = 0, HNDS = 0).....	484
Figure 15.23	Sample Flowchart for Slave Transmit Mode.....	485
Figure 15.24	Slave Transmit Mode Operation Timing Example (MLS = 0).....	487
Figure 15.25	IRIC Setting Timing and SCL Control (1).....	488
Figure 15.26	IRIC Setting Timing and SCL Control (2).....	489
Figure 15.27	IRIC Setting Timing and SCL Control (3).....	490
Figure 15.28	Block Diagram of Noise Canceler.....	492

Figure 15.29	Notes on Reading Master Receive Data	500
Figure 15.30	Flowchart for Start Condition Issuance Instruction for Retransmission and Timing	501
Figure 15.31	Stop Condition Issuance Timing	502
Figure 15.32	IRIC Flag Clearing Timing When WAIT = 1	502
Figure 15.33	ICDR Register Read and ICCR Register Access Timing in Slave Transmit Mode	503
Figure 15.34	TRS Bit Set Timing in Slave Mode	504
Figure 15.35	Diagram of Erroneous Operation when Arbitration Lost	506
Section 16 LPC Interface (LPC)		
Figure 16.1	Block Diagram of LPC	508
Figure 16.2	Typical LFRAME Timing	569
Figure 16.3	Abort Mechanism	569
Figure 16.4	SMIC Write Transfer Flow	570
Figure 16.5	SMIC Read Transfer Flow	571
Figure 16.6	BT Write Transfer Flow	572
Figure 16.7	BT Read Transfer Flow	573
Figure 16.8	GA20 Output	575
Figure 16.9	Power-Down State Termination Timing	580
Figure 16.10	SERIRQ Timing	581
Figure 16.11	Clock Start or Speed-Up	583
Figure 16.12	HIRQ Flowchart (Example of Channel 1)	586
Section 17 D/A Converter		
Figure 17.1	Block Diagram of D/A Converter	589
Figure 17.2	D/A Converter Operation Example	593
Section 18 A/D Converter		
Figure 18.1	Block Diagram of A/D Converter	596
Figure 18.2	A/D Conversion Timing	602
Figure 18.3	External Trigger Input Timing	603
Figure 18.4	A/D Conversion Accuracy Definitions	605
Figure 18.5	A/D Conversion Accuracy Definitions	605
Figure 18.6	Example of Analog Input Circuit	606
Figure 18.7	Example of Analog Input Protection Circuit	608
Figure 18.8	Analog Input Pin Equivalent Circuit	608
Section 20 Flash Memory (0.18-μm F-ZTAT Version)		
Figure 20.1	Block Diagram of Flash Memory	612
Figure 20.2	Mode Transition of Flash Memory	613
Figure 20.3	Flash Memory Configuration	615
Figure 20.4	Block Division of User MAT	617
Figure 20.5	Overview of User Procedure Program	618
Figure 20.6	System Configuration in Boot Mode	639

Figure 20.7	Automatic-Bit-Rate Adjustment Operation of SCI	639
Figure 20.8	Overview of Boot Mode State Transition Diagram.....	641
Figure 20.9	Programming/Erasing Overview Flow.....	642
Figure 20.10	RAM Map When Programming/Erasing is Executed	643
Figure 20.11	Programming Procedure.....	644
Figure 20.12	Erasing Procedure	649
Figure 20.13	Repeating Procedure of Erasing and Programming.....	651
Figure 20.14	Procedure for Programming User MAT in User Boot Mode	653
Figure 20.15	Procedure for Erasing User MAT in User Boot Mode.....	654
Figure 20.16	Transitions to Error-Protection State.....	667
Figure 20.17	Switching between the User MAT and User Boot MAT	668
Figure 20.18	Memory Map in Programmer Mode.....	669
Figure 20.19	Boot Program States.....	671
Figure 20.20	Bit-Rate-Adjustment Sequence	672
Figure 20.21	Communication Protocol Format	673
Figure 20.22	New Bit-Rate Selection Sequence.....	683
Figure 20.23	Programming Sequence.....	686
Figure 20.24	Erasure Sequence	689

Section 21 Boundary Scan (JTAG)

Figure 21.1	JTAG Block Diagram.....	698
Figure 21.2	TAP Controller State Transitions	714
Figure 21.3	Reset Signal Circuit Without Reset Signal Interference.....	718
Figure 21.4	Serial Data Input/Output (1).....	719
Figure 21.5	Serial Data Input/Output (2).....	720

Section 22 Clock Pulse Generator

Figure 22.1	Block Diagram of Clock Pulse Generator	721
Figure 22.2	Typical Connection to Crystal Resonator.....	722
Figure 22.3	Equivalent Circuit of Crystal Resonator.....	722
Figure 22.4	Example of External Clock Input.....	723
Figure 22.5	Note on Board Design of Oscillation Circuit Section	725

Section 23 Power-Down Modes

Figure 23.1	Mode Transition Diagram	736
Figure 23.2	Medium-Speed Mode Timing	740
Figure 23.3	Software Standby Mode Application Example	742
Figure 23.4	Hardware Standby Mode Timing	743

Section 25 Electrical Characteristics

Figure 25.1	Darlington Transistor Drive Circuit (Example).....	787
Figure 25.2	LED Drive Circuit (Example).....	787
Figure 25.3	Output Load Circuit	788
Figure 25.4	System Clock Timing.....	789
Figure 25.5	Oscillation Stabilization Timing.....	790

Figure 25.6	Oscillation Stabilization Timing (Exiting Software Standby Mode)	790
Figure 25.7	External Clock Input Timing	790
Figure 25.8	Timing of External Clock Output Stabilization Delay Time	791
Figure 25.9	Subclock Input Timing	791
Figure 25.10	Reset Input Timing	792
Figure 25.11	Interrupt Input Timing	793
Figure 25.12	Basic Bus Timing/2-State Access	795
Figure 25.13	Basic Bus Timing/3-State Access	796
Figure 25.14	Basic Bus Timing/3-State Access with One Wait State	797
Figure 25.15	Burst ROM Access Timing/2-State Access	798
Figure 25.16	Burst ROM Access Timing/1-State Access	799
Figure 25.17	Multiplex Bus Timing/Data 2-State Access	801
Figure 25.18	Multiplex Bus Timing/Data 3-State Access	801
Figure 25.19	I/O Port Input/Output Timing	804
Figure 25.20	FRT Input/Output Timing	804
Figure 25.21	FRT Clock Input Timing	804
Figure 25.22	8-Bit Timer Output Timing	804
Figure 25.23	8-Bit Timer Clock Input Timing	805
Figure 25.24	8-Bit Timer Reset Input Timing	805
Figure 25.25	PWM, PWMX Output Timing	805
Figure 25.26	SCK Clock Input Timing	805
Figure 25.27	SCI Input/Output Timing (Clock Synchronous Mode)	806
Figure 25.28	A/D Converter External Trigger Input Timing	806
Figure 25.29	WDT Output Timing ($\overline{\text{RESO}}$)	806
Figure 25.30	I ² C Bus Interface Input/Output Timing	808
Figure 25.31	LPC Interface (LPC) Timing	809
Figure 25.32	JTAG ETCK Timing	810
Figure 25.33	Reset Hold Timing	810
Figure 25.34	JTAG Input/Output Timing	810
Figure 25.35	Connection of VCL Capacitor	816

Appendix

Figure C.1	Package Dimensions (TFP-144)	820
------------	------------------------------	-----

Tables

Section 1 Overview

Table 1.1	Pin Arrangement in Each Operating Mode.....	4
Table 1.2	Pin Functions	9

Section 2 CPU

Table 2.1	Instruction Classification	31
Table 2.2	Operation Notation	32
Table 2.3	Data Transfer Instructions.....	33
Table 2.4	Arithmetic Operations Instructions (1)	34
Table 2.4	Arithmetic Operations Instructions (2)	35
Table 2.5	Logic Operations Instructions.....	36
Table 2.6	Shift Instructions.....	36
Table 2.7	Bit Manipulation Instructions (1).....	37
Table 2.7	Bit Manipulation Instructions (2).....	38
Table 2.8	Branch Instructions.....	39
Table 2.9	System Control Instructions.....	40
Table 2.10	Block Data Transfer Instructions	41
Table 2.11	Addressing Modes	43
Table 2.12	Absolute Address Access Ranges.....	45
Table 2.13	Effective Address Calculation (1).....	47
Table 2.13	Effective Address Calculation (2).....	48

Section 3 MCU Operating Modes

Table 3.1	MCU Operating Mode Selection	53
Table 3.2	Pin Functions in Each Mode.....	59

Section 4 Exception Handling

Table 4.1	Exception Types and Priority.....	63
Table 4.2	Exception Handling Vector Table.....	64
Table 4.2	Exception Handling Vector Table (cont)	65
Table 4.3	Status of CCR after Trap Instruction Exception Handling	68

Section 5 Interrupt Controller

Table 5.1	Pin Configuration.....	73
Table 5.2	Correspondence between Interrupt Source and ICR	75
Table 5.3	Interrupt Sources, Vector Addresses, and Interrupt Priorities.....	85
Table 5.3	Interrupt Sources, Vector Addresses, and Interrupt Priorities (cont)	86
Table 5.3	Interrupt Sources, Vector Addresses, and Interrupt Priorities (cont)	87
Table 5.4	Interrupt Control Modes	88
Table 5.5	Interrupts Selected in Each Interrupt Control Mode	89
Table 5.6	Operations and Control Signal Functions in Each Interrupt Control Mode.....	90
Table 5.7	Interrupt Response Times	96

Table 5.8	Number of States in Interrupt Handling Routine Execution Status	96
Table 5.9	Interrupt Source Selection and Clearing Control	98

Section 6 Bus Controller (BSC)

Table 6.1	Pin Configuration.....	104
Table 6.2	Address Ranges and External Address Spaces	113
Table 6.3	Bit Settings and Bus Specifications of Basic Bus Interface.....	114
Table 6.4	Bus Specifications for Basic Extended Area/Basic Bus Interface	115
Table 6.5	Bus Specifications for 256-kbyte Extended Area/Basic Bus Interface	116
Table 6.6	Bus Specifications for CP Extended Area (Basic Mode)/Basic Bus Interface	117
Table 6.7	Address-Data Multiplex Address Spaces.....	119
Table 6.8	Bit Settings and Bus Specifications of Basic Bus Interface.....	120
Table 6.9	Bus Specifications for IOS Extended Area/Multiplex Bus Interface (Address Cycle)	120
Table 6.10	Bus Specifications for IOS Extended Area/Multiplex Bus Interface (Data Cycle)	120
Table 6.11	Bus Specifications for 256-kbyte Extended Area/Multiplex Bus Interface (Address Cycle).....	121
Table 6.12	Bus Specifications for 256-kbyte Extended Area/Multiplex Bus Interface (Data Cycle)	121
Table 6.13	Bus Specifications for CP Extended Area/Multiplex Bus Interface (Address Cycle).....	121
Table 6.14	Bus Specifications for CP Extended Area/Multiplex Bus Interface (Data Cycle)	122
Table 6.15	Address Range for $\overline{\text{IOS}}$ Signal Output.....	123
Table 6.16	Data Buses Used and Valid Strokes.....	126
Table 6.17	Pin States in Idle Cycle.....	147

Section 7 Data Transfer Controller (DTC)

Table 7.1	Correspondence between Interrupt Sources and DTCER.....	155
Table 7.2	DTC Event Counter Conditions.....	159
Table 7.3	Flag Status/Address Code.....	160
Table 7.4	Interrupt Sources, DTC Vector Addresses, and Corresponding DTCEs	163
Table 7.4	Interrupt Sources, DTC Vector Addresses, and Corresponding DTCEs (cont)....	164
Table 7.5	Register Functions in Normal Mode.....	166
Table 7.6	Register Functions in Repeat Mode.....	167
Table 7.7	Register Functions in Block Transfer Mode.....	168
Table 7.8	DTC Execution Status	171
Table 7.9	Number of States Required for Each Execution Status	172

Section 8 I/O Ports

Table 8.1	Port Functions.....	177
Table 8.1	Port Functions (cont)	178
Table 8.1	Port Functions (cont)	179

Table 8.1	Port Functions (cont)	180
Table 8.1	Port Functions (cont)	181
Table 8.1	Port Functions (cont)	182
Table 8.2	Port 1 Input Pull-Up MOS States.....	186
Table 8.3	Port 2 Input Pull-Up MOS States.....	190
Table 8.4	Port 3 Input Pull-Up MOS States.....	195
Table 8.5	Port 6 Input Pull-Up MOS States.....	213
Table 8.6	Port A Input Pull-Up MOS States.....	231
Table 8.7	Port D Input Pull-Up MOS States.....	242
Section 9 8-Bit PWM Timer (PWM)		
Table 9.1	Pin Configuration.....	252
Table 9.2	Internal Clock Selection.....	254
Table 9.3	Resolution, PWM Conversion Period, and Carrier Frequency when $\phi = 33$ MHz	255
Table 9.4	Duty Cycle of Basic Pulse	258
Table 9.5	Position of Pulses Added to Basic Pulses	259
Section 10 14-Bit PWM Timer (PWMX)		
Table 10.1	Pin Configuration.....	262
Table 10.2	Clock Select of PWMX_1 and PWMX_0	267
Table 10.3	Settings and Operation (Examples when $\phi = 33$ MHz).....	270
Table 10.4	Locations of Additional Pulses Added to Base Pulse (When CFS = 1).....	275
Section 11 16-Bit Free-Running Timer (FRT)		
Table 11.1	Pin Configuration.....	279
Table 11.2	FRT Interrupt Sources	298
Table 11.3	Switching of Internal Clock and FRC Operation	303
Table 11.3	Switching of Internal Clock and FRC Operation (cont)	304
Section 12 8-Bit Timer (TMR)		
Table 12.1	Pin Configuration.....	308
Table 12.2	Clock Input to TCNT and Count Condition.....	312
Table 12.2	Clock Input to TCNT and Count Condition (cont)	313
Table 12.3	Registers Accessible by TMR_X/TMR_Y	321
Table 12.4	Input Capture Signal Selection	328
Table 12.5	Interrupt Sources of 8-Bit Timers TMR_0, TMR_1, TMR_Y, and TMR_X	329
Table 12.6	Timer Output Priorities	333
Table 12.7	Switching of Internal Clocks and TCNT Operation.....	333
Table 12.7	Switching of Internal Clocks and TCNT Operation (cont).....	334
Section 13 Watchdog Timer (WDT)		
Table 13.1	Pin Configuration.....	339
Table 13.2	WDT Interrupt Source	347

Section 14 Serial Communication Interface (SCI, IrDA, and CRC)

Table 14.1	Pin Configuration.....	355
Table 14.2	Relationships between N Setting in BRR and Bit Rate B.....	369
Table 14.3	Examples of BRR Settings for Various Bit Rates (Asynchronous Mode) (1)	370
Table 14.3	Examples of BRR Settings for Various Bit Rates (Asynchronous Mode) (2)	371
Table 14.4	Maximum Bit Rate for Each Frequency (Asynchronous Mode)	372
Table 14.5	Maximum Bit Rate with External Clock Input (Asynchronous Mode)	372
Table 14.6	BRR Settings for Various Bit Rates (Clock Synchronous Mode).....	373
Table 14.7	Maximum Bit Rate with External Clock Input (Clock Synchronous Mode).....	373
Table 14.8	BRR Settings for Various Bit Rates (Smart Card Interface Mode, n = 0, s = 372).....	374
Table 14.9	Maximum Bit Rate for Each Frequency (Smart Card Interface Mode, S = 372).....	374
Table 14.10	Asynchronous Mode Clock Source Select.....	378
Table 14.11	Serial Transfer Formats (Asynchronous Mode).....	381
Table 14.12	SSR Status Flags and Receive Data Handling	390
Table 14.13	IrCKS2 to IrCKS0 Bit Settings.....	419
Table 14.14	SCI Interrupt Sources.....	420
Table 14.15	SCI Interrupt Sources.....	421

Section 15 I²C Bus Interface (IIC)

Table 15.1	Pin Configuration.....	438
Table 15.2	Transfer Format	441
Table 15.3	I ² C bus Transfer Rate (1).....	444
Table 15.3	I ² C bus Transfer Rate (2).....	445
Table 15.4	Flags and Transfer States (Master Mode).....	452
Table 15.5	Flags and Transfer States (Slave Mode)	453
Table 15.6	Output Data Hold Time	464
Table 15.7	ISCMBCR Setting	464
Table 15.8	I ² C Bus Data Format Symbols.....	466
Table 15.9	Examples of Operation Using the DTC	491
Table 15.10	IIC Interrupt Source.....	494
Table 15.11	I ² C Bus Timing (SCL and SDA Outputs).....	495
Table 15.12	Permissible SCL Rise Time (t _{sr}) Values	496
Table 15.13	I ² C Bus Timing (with Maximum Influence of t _{sr} /t _{sf}).....	498

Section 16 LPC Interface (LPC)

Table 16.1	Pin Configuration.....	509
Table 16.2	LADR1, LADR2 Initial Values	526
Table 16.3	Host Register Selection.....	526
Table 16.4	Slave Selection Internal Registers	527
Table 16.5	I/O Read and Write Cycles	568
Table 16.6	GA20 (PD3) Set/Clear Conditions.....	574

Table 16.7	Fast A20 Gate Output Signals.....	576
Table 16.8	Scope of LPC Interface Pin Shutdown	578
Table 16.9	Scope of Initialization in Each LPC Interface Mode	579
Table 16.10	Serial Interrupt Transfer Cycle Frame Configuration	582
Table 16.11	Receive Complete Interrupts and Error Interrupt.....	584
Table 16.12	HIRQ Setting and Clearing Conditions.....	585
Table 16.13	Host Addresses Example	588

Section 17 D/A Converter

Table 17.1	Pin Configuration.....	590
Table 17.2	D/A Channel Enable	592

Section 18 A/D Converter

Table 18.1	Pin Configuration.....	597
Table 18.2	Analog Input Channels and Corresponding ADDR Registers	598
Table 18.3	A/D Conversion Time (Single Mode).....	603
Table 18.4	A/D Converter Interrupt Source.....	604

Section 20 Flash Memory (0.18- μ m F-ZTAT Version)

Table 20.1	Comparison of Programming Modes	614
Table 20.2	Pin Configuration.....	620
Table 20.3	Register/Parameter and Target Mode	621
Table 20.4	Parameters and Target Modes.....	629
Table 20.5	Setting On-Board Programming Mode	638
Table 20.6	System Clock Frequency for Automatic-Bit-Rate Adjustment by This LSI.....	640
Table 20.7	Executable MAT.....	656
Table 20.8 (1)	Useable Area for Programming in User Program Mode.....	657
Table 20.8 (2)	Useable Area for Erasure in User Program Mode.....	659
Table 20.8 (3)	Useable Area for Programming in User Boot Mode.....	661
Table 20.8 (4)	Useable Area for Erasure in User Boot Mode.....	663
Table 20.9	Hardware Protection	665
Table 20.10	Software Protection.....	666
Table 20.11	Inquiry and Selection Commands.....	674
Table 20.12	Programming/Erasing Command.....	685
Table 20.13	Status Code	694
Table 20.14	Error Code	694

Section 21 Boundary Scan (JTAG)

Table 21.1	Pin Configuration.....	699
Table 21.2	JTAG Register Serial Transfer.....	700
Table 21.3	Correspondence between Pins and Boundary Scan Register	704

Section 22 Clock Pulse Generator

Table 22.1	Damping Resistance Values	722
Table 22.2	Crystal Resonator Parameters	723
Table 22.3	PFSEL and Multipliers	724

Section 23 Power-Down Modes

Table 23.1	Operating Frequency and Wait Time.....	730
Table 23.2	LSI Internal States in Each Mode.....	737

Section 25 Electrical Characteristics

Table 25.1	Absolute Maximum Ratings.....	783
Table 25.2	DC Characteristics (1).....	784
Table 25.2	DC Characteristics (2).....	785
Table 25.3	Permissible Output Currents.....	787
Table 25.4	Clock Timing.....	788
Table 25.5	External Clock Input Conditions.....	789
Table 25.6	Subclock Input Conditions.....	789
Table 25.7	Control Signal Timing.....	792
Table 25.8	Bus Timing.....	794
Table 25.9	Multiplex Bus Timing.....	800
Table 25.10	Timing of On-Chip Peripheral Modules.....	803
Table 25.11	I ² C Bus Timing.....	807
Table 25.12	LPC Module Timing.....	808
Table 25.13	JTAG Timing.....	809
Table 25.14	A/D Conversion Characteristics (AN7 to AN0 Input: 134/266-State Conversion).....	811
Table 25.15	D/A Conversion Characteristics.....	812
Table 25.16	Flash Memory Characteristics.....	813

Section 1 Overview

1.1 Overview

- High-speed H8S/2000 central processing unit with an internal 16-bit architecture
Upward-compatible with H8/300 and H8/300H CPUs on an object level
Sixteen 16-bit general registers
65 basic instructions
- Various peripheral functions
Data transfer controller (DTC)
8-bit PWM timer (PWM)
14-bit PWM timer (PWMX)
16-bit free-running timer (FRT)
8-bit timer (TMR)
Watchdog timer (WDT)
Asynchronous or clocked synchronous serial communication interface (SCI)
CRC operation circuit (CRC)
I²C bus interface (IIC)
LPC interface (LPC)
8-bit D/A converter
10-bit A/D converter
Boundary scan (JTAG)
Clock pulse generator

- On-chip memory

ROM Type	Model	ROM	RAM	Remarks
Flash memory Version	HD64F2168	256 kbytes	40 kbytes	
Flash memory Version	HD64F2167	384 kbytes	40 kbytes	
Flash memory Version	HD64F2166	512 kbytes	40 kbytes	

- General I/O ports
I/O pins: 106
Input-only pins: 9
- Supports various power-down states
- Compact package

Package	Code	Body Size	Pin Pitch
TQFP-144	TFP-144	16.0 × 16.0 mm	0.4 mm

1.2 Internal Block Diagram

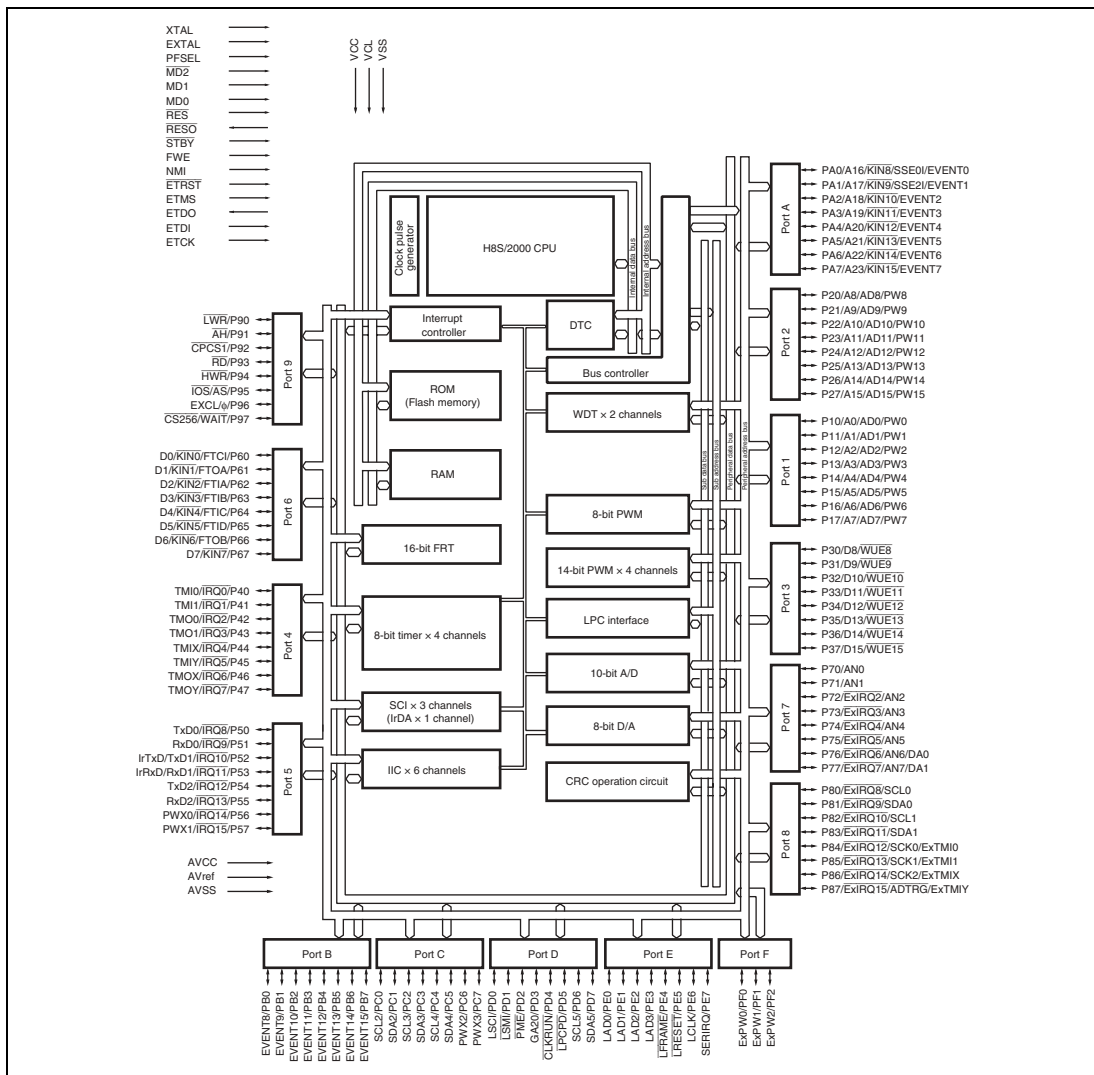

Figure 1.1 Internal Block Diagram

1.3 Pin Description

1.3.1 Pin Arrangement

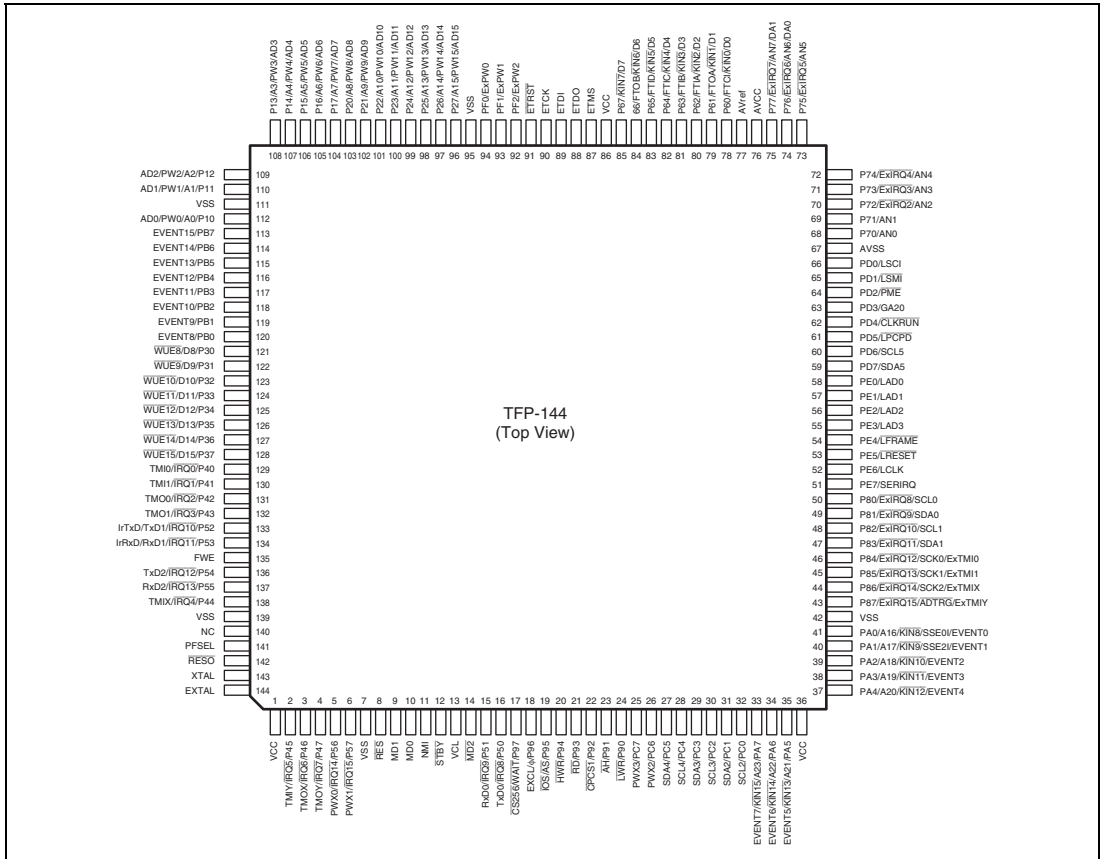

Figure 1.2 Pin Arrangement (TFP-144)

1.3.2 Pin Arrangement in Each Operating Mode

Table 1.1 Pin Arrangement in Each Operating Mode

Pin No.	Pin Name		
TFP-144	Extended Mode (EXPE = 1)	Single-Chip Mode (EXPE = 0)	Flash Memory Programmer Mode
1	VCC	VCC	VCC
2	P45/ $\overline{\text{IRQ5}}$ /TMIY	P45/ $\overline{\text{IRQ5}}$ /TMIY	NC
3	P46/ $\overline{\text{IRQ6}}$ /TMOX	P46/ $\overline{\text{IRQ6}}$ /TMOX	NC
4	P47/ $\overline{\text{IRQ7}}$ /TMOY	P47/ $\overline{\text{IRQ7}}$ /TMOY	NC
5	P56/ $\overline{\text{IRQ14}}$ /PWX0	P56/ $\overline{\text{IRQ14}}$ /PWX0	NC
6	P57/ $\overline{\text{IRQ15}}$ /PWX1	P57/ $\overline{\text{IRQ15}}$ /PWX1	NC
7	VSS	VSS	VSS
8	$\overline{\text{RES}}$	$\overline{\text{RES}}$	$\overline{\text{RES}}$
9	MD1	MD1	VSS
10	MD0	MD0	VSS
11	NMI	NMI	FA9
12	$\overline{\text{STBY}}$	$\overline{\text{STBY}}$	VCC
13	VCL	VCL	VCL
14	$\overline{\text{MD2}}$	$\overline{\text{MD2}}$	VCC
15	P51/ $\overline{\text{IRQ9}}$ /RxD0	P51/ $\overline{\text{IRQ9}}$ /RxD0	FA17
16	P50/ $\overline{\text{IRQ8}}$ /TxD0	P50/ $\overline{\text{IRQ8}}$ /TxD0	NC
17	P97/ $\overline{\text{WAIT/CS256}}$	P97	VCC
18	P96/ ϕ /EXCL	P96/ ϕ /EXCL	NC
19	$\overline{\text{AS}}/\overline{\text{IOS}}$	P95	FA16
20	$\overline{\text{HWR}}$	P94	FA15
21	$\overline{\text{RD}}$	P93	$\overline{\text{WE}}$
22	P92/ $\overline{\text{CPCS1}}$	P92	VSS
23	P91/ $\overline{\text{AH}}$	P91	VCC
24	P90/ $\overline{\text{LWR}}$	P90	VCC
25	PC7/PWX3	PC7/PWX3	NC
26	PC6/PWX2	PC6/PWX2	NC
27	PC5/SDA4	PC5/SDA4	NC

Pin No.	Pin Name		
TFP-144	Extended Mode (EXPE = 1)	Single-Chip Mode (EXPE = 0)	Flash Memory Programmer Mode
28	PC4/SCL4	PC4/SCL4	NC
29	PC3/SDA3	PC3/SDA3	NC
30	PC2/SCL3	PC2/SCL3	NC
31	PC1/SDA2	PC1/SDA2	NC
32	PC0/SCL2	PC0/SCL2	NC
33	PA7/A23/KIN15/EVENT7	PA7/KIN15/EVENT7	NC
34	PA6/A22/KIN14/EVENT6	PA6/KIN14/EVENT6	NC
35	PA5/A21/KIN13/EVENT5	PA5/KIN13/EVENT5	NC
36	VCC	VCC	VCC
37	PA4/A20/KIN12/EVENT4	PA4/KIN12/EVENT4	NC
38	PA3/A19/KIN11/EVENT3	PA3/KIN11/EVENT3	NC
39	PA2/A18/KIN10/EVENT2	PA2/KIN10/EVENT2	NC
40	PA1/A17/KIN9/EVENT1/SSE2I	PA1/KIN9/EVENT1/SSE2I	NC
41	PA0/A16/KIN8/EVENT0/SSE0I	PA0/KIN8/EVENT0/SSE0I	NC
42	VSS	VSS	VSS
43	P87/ExIRQ15/ADTRG/ExTMIY	P87/ExIRQ15/ADTRG/ExTMIY	NC
44	P86/ExIRQ14/SCK2/ExTMIX	P86/ExIRQ14/SCK2/ExTMIX	NC
45	P85/ExIRQ13/SCK1/ExTMI1	P85/ExIRQ13/SCK1/ExTMI1	NC
46	P84/ExIRQ12/SCK0/ExTMI0	P84/ExIRQ12/SCK0/ExTMI0	NC
47	P83/ExIRQ11/SDA1	P83/ExIRQ11/SDA1	NC
48	P82/ExIRQ10/SCL1	P82/ExIRQ10/SCL1	NC
49	P81/ExIRQ9/SDA0	P81/ExIRQ9/SDA0	NC
50	P80/ExIRQ8/SCL0	P80/ExIRQ8/SCL0	NC
51	PE7/SERIRQ	PE7/SERIRQ	NC
52	PE6/LCLK	PE6/LCLK	NC
53	PE5/LRESET	PE5/LRESET	NC
54	PE4/LFRAME	PE4/LFRAME	NC
55	PE3/LAD3	PE3/LAD3	NC
56	PE2/LAD2	PE2/LAD2	NC
57	PE1/LAD1	PE1/LAD1	NC
58	PE0/LAD0	PE0/LAD0	NC

Pin No.	Pin Name		
TFFP-144	Extended Mode (EXPE = 1)	Single-Chip Mode (EXPE = 0)	Flash Memory Programmer Mode
59	PD7/SDA5	PD7/SDA5	NC
60	PD6/SCL5	PD6/SCL5	NC
61	PD5/LPCPD	PD5/LPCPD	NC
62	PD4/CLKRUN	PD4/CLKRUN	NC
63	PD3/GA20	PD3/GA20	NC
64	PD2/PME	PD2/PME	NC
65	PD1/LSM \bar{I}	PD1/LSM \bar{I}	NC
66	PD0/LSCI	PD0/LSCI	NC
67	AVSS	AVSS	VSS
68	P70/AN0	P70/AN0	NC
69	P71/AN1	P71/AN1	NC
70	P72/ExIRQ2/AN2	P72/ExIRQ2/AN2	NC
71	P73/ExIRQ3/AN3	P73/ExIRQ3/AN3	NC
72	P74/ExIRQ4/AN4	P74/ExIRQ4/AN4	NC
73	P75/ExIRQ5/AN5	P75/ExIRQ5/AN5	NC
74	P76/ExIRQ6/AN6/DA0	P76/ExIRQ6/AN6/DA0	NC
75	P77/ExIRQ7/AN7/DA1	P77/ExIRQ7/AN7/DA1	NC
76	AVCC	AVCC	VCC
77	AVref	AVref	VCC
78	P60/FTCI/KIN0/D0	P60/FTCI/KIN0	NC
79	P61/FTOA/KIN1/D1	P61/FTOA/KIN1	NC
80	P62/FTIA/KIN2/D2	P62/FTIA/KIN2	NC
81	P63/FTIB/KIN3/D3	P63/FTIB/KIN3	NC
82	P64/FTIC/KIN4/D4	P64/FTIC/KIN4	NC
83	P65/FTID/KIN5/D5	P65/FTID/KIN5	NC
84	P66/FTOB/KIN6/D6	P66/FTOB/KIN6	NC
85	P67/KIN7/D7	P67/KIN7	VSS
86	VCC	VCC	VCC
87	ETMS	ETMS	NC
88	ETDO	ETDO	NC
89	ETDI	ETDI	NC

Pin No.	Pin Name		
TFP-144	Extended Mode (EXPE = 1)	Single-Chip Mode (EXPE = 0)	Flash Memory Programmer Mode
90	ETCK	ETCK	NC
91	ETRST	ETRST	RES
92	PF2/ExPW2	PF2/ExPW2	NC
93	PF1/ExPW1	PF1/ExPW1	NC
94	PF0/ExPW0	PF0/ExPW0	NC
95	VSS	VSS	VSS
96	P27/A15/AD15	P27/PW15	CE
97	P26/A14/AD14	P26/PW14	FA14
98	P25/A13/AD13	P25/PW13	FA13
99	P24/A12/AD12	P24/PW12	FA12
100	P23/A11/AD11	P23/PW11	FA11
101	P22/A10/AD10	P22/PW10	FA10
102	P21/A9/AD9	P21/PW9	OE
103	P20/A8/AD8	P20/PW8	FA8
104	P17/A7/AD7	P17/PW7	FA7
105	P16/A6/AD6	P16/PW6	FA6
106	P15/A5/AD5	P15/PW5	FA5
107	P14/A4/AD4	P14/PW4	FA4
108	P13/A3/AD3	P13/PW3	FA3
109	P12/A2/AD2	P12/PW2	FA2
110	P11/A1/AD1	P11/PW1	FA1
111	VSS	VSS	VSS
112	P10/A0/AD0	P10/PW0	FA0
113	PB7/EVENT15	PB7/EVENT15	NC
114	PB6/EVENT14	PB6/EVENT14	NC
115	PB5/EVENT13	PB5/EVENT13	NC
116	PB4/EVENT12	PB4/EVENT12	NC
117	PB3/EVENT11	PB3/EVENT11	NC
118	PB2/EVENT10	PB2/EVENT10	NC
119	PB1/EVENT9	PB1/EVENT9	NC
120	PB0/EVENT8	PB0/EVENT8	NC

Pin No.	Pin Name		Flash Memory Programmer Mode
TFP-144	Extended Mode	Single-Chip Mode	
121	P30/D8/ $\overline{WUE8}$	P30/ $\overline{WUE8}$	FO0
122	P31/D9/ $\overline{WUE9}$	P31/ $\overline{WUE9}$	FO1
123	P32/D10/ $\overline{WUE10}$	P32/ $\overline{WUE10}$	FO2
124	P33/D11/ $\overline{WUE11}$	P33/ $\overline{WUE11}$	FO3
125	P34/D12/ $\overline{WUE12}$	P34/ $\overline{WUE12}$	FO4
126	P35/D13/ $\overline{WUE13}$	P35/ $\overline{WUE13}$	FO5
127	P36/D14/ $\overline{WUE14}$	P36/ $\overline{WUE14}$	FO6
128	P37/D15/ $\overline{WUE15}$	P37/ $\overline{WUE15}$	FO7
129	P40/ $\overline{IRQ0}$ /TMI0	P40/ $\overline{IRQ0}$ /TMI0	NC
130	P41/ $\overline{IRQ1}$ /TMI1	P41/ $\overline{IRQ1}$ /TMI1	NC
131	P42/ $\overline{IRQ2}$ /TMO0	P42/ $\overline{IRQ2}$ /TMO0	NC
132	P43/ $\overline{IRQ3}$ /TMO1	P43/ $\overline{IRQ3}$ /TMO1	NC
133	P52/ $\overline{IRQ10}$ /TxD1/IrTxD	P52/ $\overline{IRQ10}$ /TxD1/IrTxD	FA18
134	P53/ $\overline{IRQ11}$ /RxD1/IrRxD	P53/ $\overline{IRQ11}$ /RxD1/IrRxD	NC
135	FWE	FWE	FWE
136	P54/ $\overline{IRQ12}$ /TxD2	P54/ $\overline{IRQ12}$ /TxD2	NC
137	P55/ $\overline{IRQ13}$ /RxD2	P55/ $\overline{IRQ13}$ /RxD2	NC
138	P44/ $\overline{IRQ4}$ /TMIX	P44/ $\overline{IRQ4}$ /TMIX	NC
139	VSS	VSS	VSS
140	NC	NC	NC
141	PFSEL	PFSEL	VCC
142	$\overline{RES0}$	$\overline{RES0}$	NC
143	XTAL	XTAL	XTAL
144	EXTAL	EXTAL	EXTAL

1.3.3 Pin Functions

Table 1.2 Pin Functions

Type	Symbol	Pin No.	I/O	Name and Function
Power supply	VCC	1, 36 86	Input	Power supply pins. Connect all these pins to the system power supply. Connect the bypass capacitor between VCC and VSS (near VCC).
	VCL	13	Input	External capacitance pin for internal step-down power. Connect this pin to Vss through an external capacitor (that is located near this pin) to stabilize internal step-down power.
	VSS	7, 42, 95, 111 139	Input	Ground pins. Connect all these pins to the system power supply (0V).
Clock	XTAL	143	Input	For connection to a crystal resonator. An external clock can be supplied from the EXTAL pin. For an example of crystal resonator connection, see section 22, Clock Pulse Generator.
	EXTAL	144	Input	
	ϕ	18	Output	Supplies the system clock to external devices.
	EXCL	18	Input	32.768-kHz external clock for sub clock should be supplied.
	PFSEL	141	Input	Pin for use by PLL. For an example of PLL connection, see section 22, Clock Pulse Generator.
Operating mode control	$\overline{\text{MD2}}$	14	Input	These pins set the operating mode. Inputs at these pins should not be changed during operation.
	MD1	9		
	MD0	10		
System control	$\overline{\text{RES}}$	8	Input	Reset pin. When this pin is low, the chip is reset.
	$\overline{\text{RESO}}$	142	Output	Outputs a reset signal to an external device.
	$\overline{\text{STBY}}$	12	Input	When this pin is low, a transition is made to hardware standby mode.
	FWE	135	Input	Pin for use by flash memory.
Address bus	A23 to A16	33 to 35 37 to 41	Output	Address output pins
	A15 to A0	96 to 110 112		
Data bus	D15 to D8	128 to 121	Input/ Output	Upper bidirectional data bus
	D7 to D0	85 to 78		Lower bidirectional data bus

Type	Symbol	Pin No.	I/O	Name and Function
Address/ data multiplex bus	AD15 to AD8	96 to 103	Input/ Output	8-bit, upper 16-bit bus
	AD7 to AD0	104 to 110, 112		Lower 16-bit bus
Bus control	$\overline{\text{WAIT}}$	17	Input	Requests insertion of a wait state in the bus cycle when accessing an external 3-state address space.
	$\overline{\text{RD}}$	21	Output	This pin is low when the external address space is being read.
	$\overline{\text{HWR}}$	20	Output	This pin is low when the external address space is to be written to, and the upper half of the data bus is enabled.
	$\overline{\text{LWR}}$	24	Output	This pin is low when the external address space is to be written to, and the lower half of the data bus is enabled.
	$\overline{\text{AS/IOS}}$	19	Output	This pin is low when address output on the address bus is valid.
	$\overline{\text{CS256}}$	17	Output	Indicates that the 256k-byte area from H'F80000 to H'FBFFFF is accessed.
	$\overline{\text{CPCS1}}$	22	Output	Indicates that the CP extended area is accessed.
	$\overline{\text{AH}}$	23	Output	Address latch signal for address/data multiplex bus.
Interrupts	NMI	11	Input	Nonmaskable interrupt request input pin
	$\overline{\text{IRQ15}}$ to $\overline{\text{IRQ0}}$	6, 5, 137, 136, 134, 133, 15, 16, 4 to 2, 138, 132 to 129	Input	These pins request a maskable interrupt. Selectable to which pin of $\overline{\text{IRQn}}$ or $\overline{\text{ExIRQn}}$ to insert IRQ15 to IRQ2 interrupts.
	$\overline{\text{ExIRQ15}}$ to $\overline{\text{ExIRQ2}}$	43 to 50 75 to 70		
Boundary scan	$\overline{\text{ETRST}}$	91	Input	Boundary scan interface pins
	ETMS	87	Input	
	ETDO	88	Output	
	ETDI	89	Input	
	ETCK	90	Input	

Type	Symbol	Pin No.	I/O	Name and Function				
PWM timer (PWM)	PW15 to PW0	96 to 110 112	Output	PWM timer pulse output pins. Selectable from which pin of PWN or ExPWN to output PW2 to PW0.				
	ExPW2 to ExPW0	92 to 94						
14-bit PWM timer (PWMX)	PWX0	5	Output	PWM D/A pulse output pins				
	PWX1	6						
	PWX2	26						
	PWX3	25						
16-bit free running timer (FRT)	FTCI	78	Input	External event input pin				
	FTOA FTOB	79 84	Output	Output compare output pins				
		FTIA to FTID	80 to 83	Input	Input capture input pins			
	8-bit timer (TMR_0, TMR_1, TMR_X, TMR_Y)	TMO0	131	Output	Waveform output pins with output compare function			
TMO1		132						
TMOX		3						
TMOY		4						
TMI0		TMI0	129	Input	External event input pins and counter reset input pins. Selectable to which pin of TMI _n or ExTMI _n to insert external event and counter reset.			
		TMI1	130					
		TMIX	138					
		TMIY	2					
		ExTMI0	46					
		ExTMI1	45					
		ExTMIX	44					
		ExTMIY	43					
		Serial communication Interface (SCI_0, SCI_1, SCI_2)	TxD0 to TxD2			16, 133 136	Output	Transmit data output pins
			RxD0 to RxD2			15, 134 137	Input	Receive data input pins
SCK0 to SCK2	46, 45 44		Input/ Output	Clock input/output pins. Output format is NMOS push-pull output.				
SSE0I	41		Input	Input pin to halt SCI_0				
SSE2I	40		Input	Input pin to halt SCI_2				
SCI with IrDA (SCI)	IrTxD		133	Output	Encoded data output pin for IrDA			
	IrRxD	134	Input	Encoded data input pin for IrDA				
I ² C bus interface (IIC)	SCL0 to SCL5	50, 48, 32, 30, 28, 60	Input/ Output	IIC clock input/output pins. These pins can drive a bus directly with the NMOS open drain output.				
	SDA0 to SDA5	49, 47, 31, 29, 27, 59	Input/ Output	IIC data input/output pins. These pins can drive a bus directly with the NMOS open drain output.				

Type	Symbol	Pin No.	I/O	Name and Function
Keyboard control	$\overline{\text{KIN15}}$ to $\overline{\text{KIN13}}$	33 to 35	Input	Matrix keyboard input pins. All pins have a wake-up function. Normally, $\overline{\text{KIN15}}$ to $\overline{\text{KIN0}}$ function as key scan inputs, and P17 to P10 and P27 to P20 function as key scan outputs. Thus, at a maximum of 16 outputs x 16 inputs, 256-key matrix can be configured.
	$\overline{\text{KIN12}}$ to $\overline{\text{KIN8}}$	37 to 41	Input	
	$\overline{\text{KIN7}}$ to $\overline{\text{KIN0}}$	85 to 78	Input	
	$\overline{\text{WUE15}}$ to $\overline{\text{WUE8}}$	128 to 121	Input	
A/D converter (ADC)	AN7 to AN0	75 to 68	Input	Analog input pins
	ADTRG	43	Input	External trigger input pin to start A/D conversion
D/A converter (DAC)	DA0 DA1	74 75	Output	Analog output pins
A/D converter (ADC)	AVCC	76	Input	Analog power supply pins for the A/D converter and D/A converter. When the A/D converter and D/A converter are not used, these pins should be connected to the system power supply (+3.3 V).
D/A converter (DAC)	AVref	77	Input	Reference voltage input pin for the A/D converter and D/A converter. When the A/D converter and D/A converter are not used, this pin should be connected to the system power supply (+3.3 V).
	AVSS	67	Input	Ground pins for the A/D converter and D/A converter. These pins should be connected to the system power supply (0 V).

Type	Symbol	Pin No.	I/O	Name and Function
LPC Interface (LPC)	LAD3 to LAD0	55 to 58	Input/ Output	Transfer cycle type/address/data I/O pins
	$\overline{\text{LFRAME}}$	54	Input	Input pin indicating transfer cycle start and forced termination
	$\overline{\text{LRESET}}$	53	Input	LPC reset pin. When this pin is low, a reset state is entered.
	LCLK	52	Input	PCI clock input pin
	SERIRQ	51	Input/ Output	LPC serialized host interrupt request signal
	LSCI, LSMI, PME	66 65 64	Input/ Output	General input/output ports of LSCI, LSMI, and PME
	GA20	63	Input/ Output	GATE A20 control signal output pin. The monitor input of an output state is enabled.
	$\overline{\text{CLKRUN}}$	62	Input/ Output	LCLK restart request I/O pin
	$\overline{\text{LPCPD}}$	61	Input	LPC module shutdown control input pin
Event Counter	EVENT15 to EVENT0	113 to 120, 33 to 35, 37 to 41	Input	Event counter input pins.

Type	Symbol	Pin No.	I/O	Name and Function
I/O ports	P17 to P10	104 to 110, 112	Input/ Output	Eight input/output pins
	P27 to P20	96 to 103	Input/ Output	Eight input/output pins
	P37 to P30	128 to 121	Input/ Output	Eight input/output pins
	P47 to P40	4 to 2, 138, 132 to 129	Input/ Output	Eight input/output pins
	P57 to P50	6, 5 137, 136 134, 133 15, 16	Input/ Output	Eight input/output pins
	P67 to P60	85 to 78	Input/ Output	Eight input/output pins
	P77 to P70	75 to 68	Input	Eight input pins
	P87 to P80	43 to 50	Input/ Output	Eight input/output pins
	P97 to P90	17 to 24	Input/ Output	Eight input/output pins (P96 input pin)
	PA7 to PA0	33 to 35, 37 to 41	Input/ Output	Eight input/output pins
	PB7 to PB0	113 to 120	Input/ Output	Eight input/output pins
	PC7 to PC0	25 to 32	Input/ Output	Eight input/output pins
	PD7 to PD0	59 to 66	Input/ Output	Eight input/output pins
	PE7 to PE0	51 to 58	Input/ Output	Eight input/output pins
	PF2 to PF0	92 to 94	Input/ Output	Three input/output pins

Section 2 CPU

The H8S/2000 CPU is a high-speed central processing unit with an internal 32-bit architecture that is upward-compatible with the H8/300 and H8/300H CPUs. The H8S/2000 CPU has sixteen 16-bit general registers, can address a 16 Mbytes linear address space, and is ideal for realtime control.

This section describes the H8S/2000 CPU. The usable modes and address spaces differ depending on the product. For details on each product, see section 3, MCU Operating Modes.

2.1 Features

- Upward-compatibility with H8/300 and H8/300H CPUs
 - Can execute H8/300 CPU and H8/300H CPU object programs
- General-register architecture
 - Sixteen 16-bit general registers also usable as sixteen 8-bit registers or eight 32-bit registers
- Sixty-five basic instructions
 - 8/16/32-bit arithmetic and logic instructions
 - Multiply and divide instructions
 - Powerful bit-manipulation instructions
- Eight addressing modes
 - Register direct [Rn]
 - Register indirect [@ERn]
 - Register indirect with displacement [@(d:16,ERn) or @(d:32,ERn)]
 - Register indirect with post-increment or pre-decrement [@ERn+ or @-ERn]
 - Absolute address [@aa:8, @aa:16, @aa:24, or @aa:32]
 - Immediate [#xx:8, #xx:16, or #xx:32]
 - Program-counter relative [@(d:8,PC) or @(d:16,PC)]
 - Memory indirect [@@aa:8]
- 16 Mbytes address space
 - Program: 16 Mbytes
 - Data: 16 Mbytes
- High-speed operation
 - All frequently-used instructions are executed in one or two states
 - 8/16/32-bit register-register add/subtract: 1 state
 - 8×8 -bit register-register multiply: 12 states (MULXU.B), 13 states (MULXS.B)
 - $16 \div 8$ -bit register-register divide: 12 states (DIVXU.B)
 - 16×16 -bit register-register multiply: 20 states (MULXU.W), 21 states (MULXS.W)
 - $32 \div 16$ -bit register-register divide: 20 states (DIVXU.W)

- Two CPU operating modes
 - Normal mode*
 - Advanced mode

Note: * Not available in this LSI.

- Power-down state
 - Transition to power-down state by SLEEP instruction
 - Selectable CPU clock speed

2.1.1 Differences between H8S/2600 CPU and H8S/2000 CPU

The differences between the H8S/2600 CPU and the H8S/2000 CPU are as shown below.

- Register configuration
 - The MAC register is supported only by the H8S/2600 CPU.
- Basic instructions
 - The four instructions MAC, CLRMAC, LDMAC, and STMAC are supported only by the H8S/2600 CPU.
- The number of execution states of the MULXU and MULXS instructions

Instruction	Mnemonic	Execution States	
		H8S/2600	H8S/2000
MULXU	MULXU.B Rs, Rd	3	12
	MULXU.W Rs, ERd	4	20
MULXS	MULXS.B Rs, Rd	4	13
	MULXS.W Rs, ERd	5	21

In addition, there are differences in address space, CCR and EXR register functions, power-down modes, etc., depending on the model.

2.1.2 Differences from H8/300 CPU

In comparison to the H8/300 CPU, the H8S/2000 CPU has the following enhancements.

- More general registers and control registers
 - Eight 16-bit extended registers and one 8-bit control register have been added.
- Extended address space
 - Normal mode* supports the same 64 kbytes address space as the H8/300 CPU.
 - Advanced mode supports a maximum 16 Mbytes address space.

Note: * Not available in this LSI.

- Enhanced addressing
 - The addressing modes have been enhanced to make effective use of the 16 Mbytes address space.
- Enhanced instructions
 - Addressing modes of bit-manipulation instructions have been enhanced.
 - Signed multiply and divide instructions have been added.
 - Two-bit shift and two-bit rotate instructions have been added.
 - Instructions for saving and restoring multiple registers have been added.
 - A test and set instruction has been added.
- Higher speed
 - Basic instructions are executed twice as fast.

2.1.3 Differences from H8/300H CPU

In comparison to the H8/300H CPU, the H8S/2000 CPU has the following enhancements.

- Additional control register
 - One 8-bit control register has been added.
- Enhanced instructions
 - Addressing modes of bit-manipulation instructions have been enhanced.
 - Two-bit shift and two-bit rotate instructions have been added.
 - Instructions for saving and restoring multiple registers have been added.
 - A test and set instruction has been added.
- Higher speed
 - Basic instructions are executed twice as fast.

2.2 CPU Operating Modes

The H8S/2000 CPU has two operating modes: normal* and advanced. Normal mode* supports a maximum 64 kbytes address space. Advanced mode supports a maximum 16 Mbytes address space. The mode is selected by the LSI's mode pins.

Note: * Not available in this LSI.

2.2.1 Normal Mode

The exception vector table and stack have the same structure as in the H8/300 CPU in normal mode.

- Address space
Linear access to a maximum address space of 64 kbytes is possible.
- Extended registers (En)
The extended registers (E0 to E7) can be used as 16-bit registers, or as the upper 16-bit segments of 32-bit registers.
When extended register En is used as a 16-bit register it can contain any value, even when the corresponding general register (Rn) is used as an address register. (If general register Rn is referenced in the register indirect addressing mode with pre-decrement (@-Rn) or post-increment (@Rn+) and a carry or borrow occurs, the value in the corresponding extended register (En) will be affected.)
- Instruction set
All instructions and addressing modes can be used. Only the lower 16 bits of effective addresses (EA) are valid.
- Exception vector table and memory indirect branch addresses
In normal mode, the top area starting at H'0000 is allocated to the exception vector table. One branch address is stored per 16 bits. The exception vector table in normal mode is shown in figure 2.1. For details of the exception vector table, see section 4, Exception Handling.
The memory indirect addressing mode (@@aa:8) employed in the JMP and JSR instructions uses an 8-bit absolute address included in the instruction code to specify a memory operand that contains a branch address. In normal mode, the operand is a 16-bit (word) operand, providing a 16-bit branch address. Branch addresses can be stored in the top area from H'0000 to H'00FF. Note that this area is also used for the exception vector table.
- Stack structure
In normal mode, when the program counter (PC) is pushed onto the stack in a subroutine call in normal mode, and the PC and condition-code register (CCR) are pushed onto the stack in exception handling, they are stored as shown in figure 2.2. The extended control register (EXR) is not pushed onto the stack. For details, see section 4, Exception Handling.

Note: Normal mode is not available in this LSI.

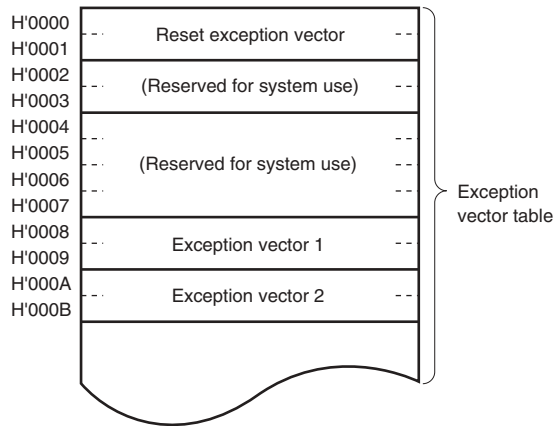
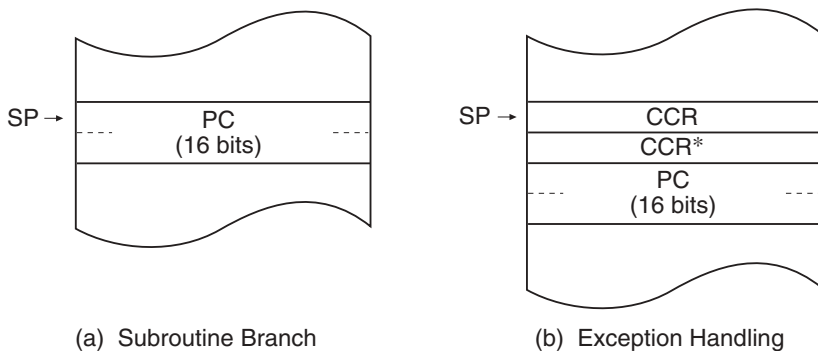

Figure 2.1 Exception Vector Table (Normal Mode)



Note: * Ignored when returning.

Figure 2.2 Stack Structure in Normal Mode

2.2.2 Advanced Mode

- Address space
Linear access to a maximum address space of 16 Mbytes is possible.
- Extended registers (En)
The extended registers (E0 to E7) can be used as 16-bit registers. They can also be used as the upper 16-bit segments of 32-bit registers or address registers.
- Instruction set
All instructions and addressing modes can be used.
- Exception vector table and memory indirect branch addresses
In advanced mode, the top area starting at H'00000000 is allocated to the exception vector table in 32-bit units. In each 32 bits, the upper eight bits are ignored and a branch address is stored in the lower 24 bits (see figure 2.3). For details of the exception vector table, see section 4, Exception Handling.

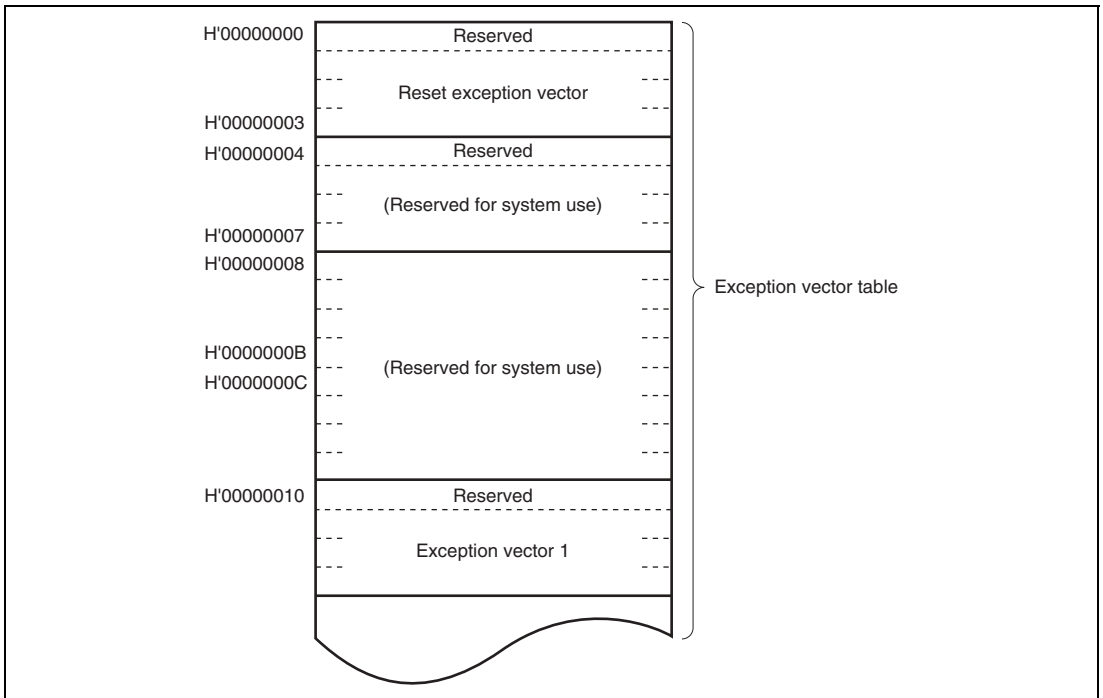

Figure 2.3 Exception Vector Table (Advanced Mode)

The memory indirect addressing mode (@@aa:8) employed in the JMP and JSR instructions uses an 8-bit absolute address included in the instruction code to specify a memory operand that contains a branch address. In advanced mode, the operand is a 32-bit longword operand, providing a 32-bit branch address. The upper eight bits of these 32 bits are a reserved area that is regarded as H'00. Branch addresses can be stored in the area from H'00000000 to H'000000FF. Note that the top area of this range is also used for the exception vector table.

- Stack structure

In advanced mode, when the program counter (PC) is pushed onto the stack in a subroutine call, and the PC and condition-code register (CCR) are pushed onto the stack in exception handling, they are stored as shown in figure 2.4. The extended control register (EXR) is not pushed onto the stack. For details, see section 4, Exception Handling.

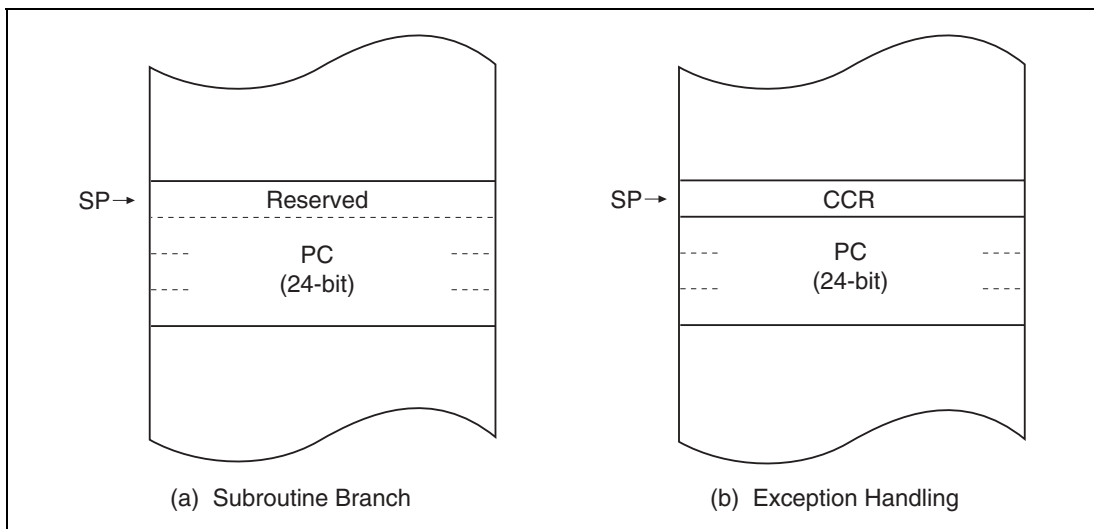

Figure 2.4 Stack Structure in Advanced Mode

2.3 Address Space

Figure 2.5 shows a memory map of the H8S/2000 CPU. The H8S/2000 CPU provides linear access to a maximum 64 kbytes address space in normal mode, and a maximum 16 Mbytes (architecturally 4 Gbytes) address space in advanced mode. The usable modes and address spaces differ depending on the product. For details on each product, see section 3, MCU Operating Modes.

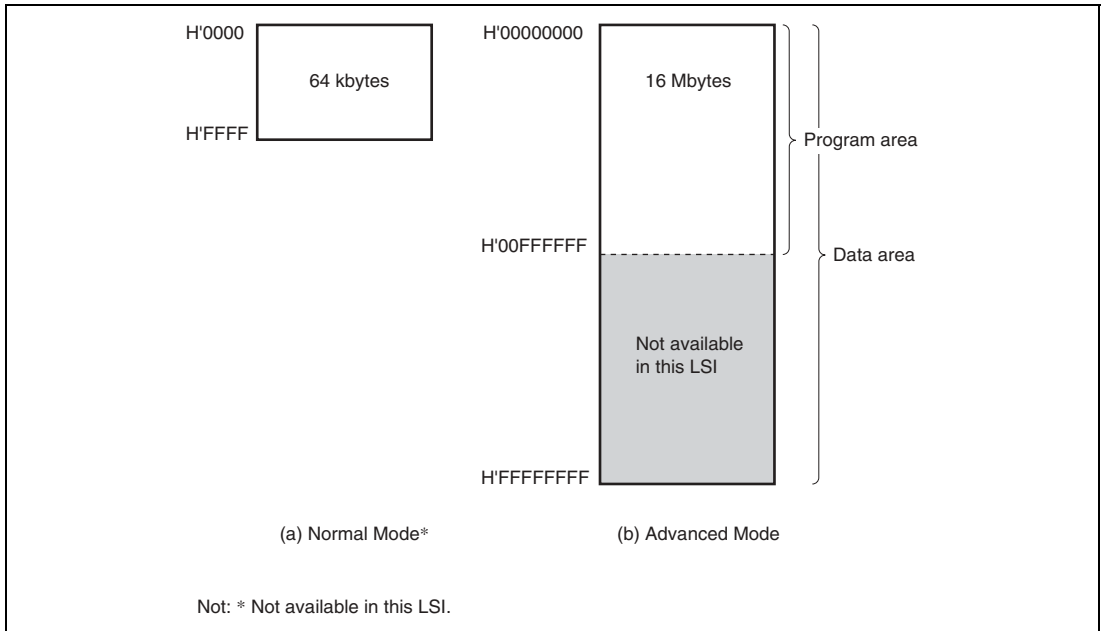

Figure 2.5 Memory Map

2.4 Register Configuration

The H8S/2000 CPU has the internal registers shown in figure 2.6. There are two types of registers: general registers and control registers. Control registers are a 24-bit program counter (PC), an 8-bit extended control register (EXR), and an 8-bit condition code register (CCR).

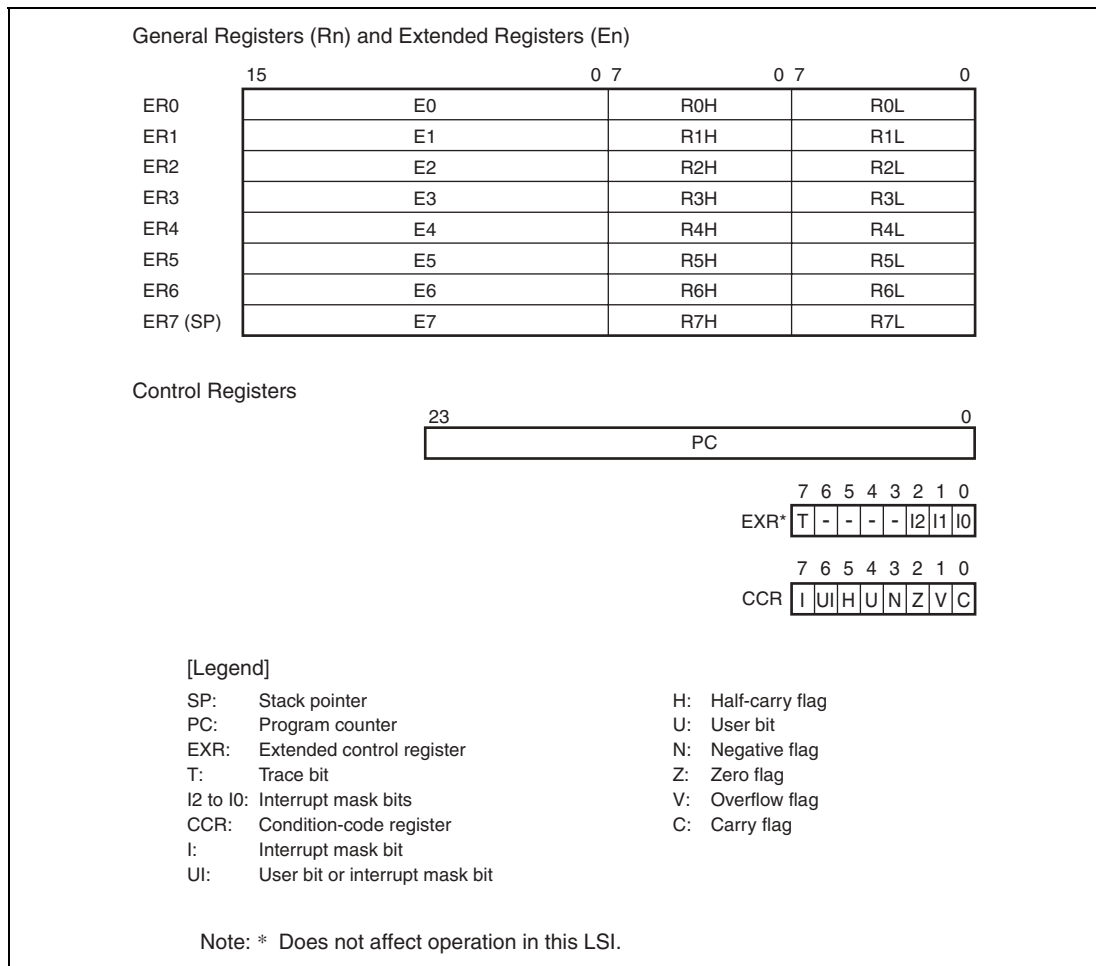

Figure 2.6 CPU Internal Registers

2.4.1 General Registers

The H8S/2000 CPU has eight 32-bit general registers. These general registers are all functionally alike and can be used as both address registers and data registers. When a general register is used as a data register, it can be accessed as a 32-bit, 16-bit, or 8-bit register. Figure 2.7 illustrates the usage of the general registers. When the general registers are used as 32-bit registers or address registers, they are designated by the letters ER (ER0 to ER7).

When the general registers are used as 16-bit registers, the ER registers are divided into 16-bit general registers designated by the letters E (E0 to E7) and R (R0 to R7). These registers are functionally equivalent, providing sixteen 16-bit registers at the maximum. The E registers (E0 to E7) are also referred to as extended registers.

When the general registers are used as 8-bit registers, the R registers are divided into 8-bit general registers designated by the letters RH (R0H to R7H) and RL (R0L to R7L). These registers are functionally equivalent, providing sixteen 8-bit registers at the maximum.

The usage of each register can be selected independently.

General register ER7 has the function of the stack pointer (SP) in addition to its general-register function, and is used implicitly in exception handling and subroutine calls. Figure 2.8 shows the stack.

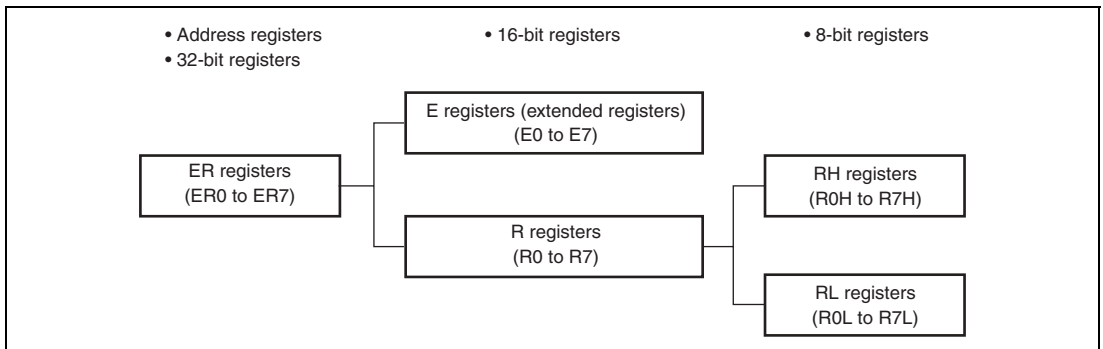

Figure 2.7 Usage of General Registers

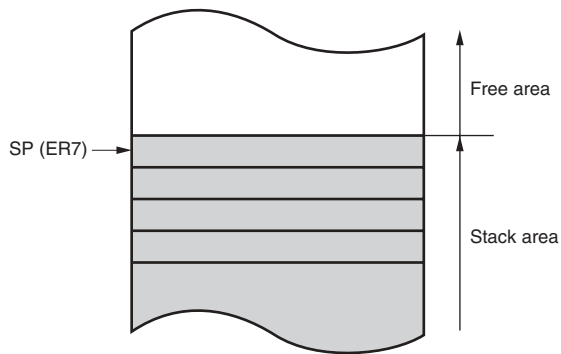

Figure 2.8 Stack

2.4.2 Program Counter (PC)

This 24-bit counter indicates the address of the next instruction the CPU will execute. The length of all CPU instructions is 2 bytes (one word), so the least significant PC bit is ignored. (When an instruction is fetched for read, the least significant PC bit is regarded as 0.)

2.4.3 Extended Control Register (EXR)

EXR does not affect operation in this LSI.

Bit	Bit Name	Initial Value	R/W	Description
7	T	0	R/W	Trace Bit Does not affect operation in this LSI.
6 to 3	–	All 1	R	Reserved These bits are always read as 1.
2 to 0	I2	1	R/W	Interrupt Mask Bits 2 to 0
	I1	1		Do not affect operation in this LSI.
	I0	1		

2.4.4 Condition-Code Register (CCR)

This 8-bit register contains internal CPU status information, including an interrupt mask bit (I) and half-carry (H), negative (N), zero (Z), overflow (V), and carry (C) flags.

Operations can be performed on the CCR bits by the LDC, STC, ANDC, ORC, and XORC instructions. The N, Z, V, and C flags are used as branching conditions for conditional branch (Bcc) instructions.

Bit	Bit Name	Initial Value	R/W	Description
7	I	1	R/W	Interrupt Mask Bit Masks interrupts other than NMI when set to 1. NMI is accepted regardless of the I bit setting. The I bit is set to 1 at the start of an exception-handling sequence. For details, see section 5, Interrupt Controller.
6	UI	Undefined	R/W	User Bit or Interrupt Mask Bit Can be written to and read from by software using the LDC, STC, ANDC, ORC, and XORC instructions.
5	H	Undefined	R/W	Half-Carry Flag When the ADD.B, ADDX.B, SUB.B, SUBX.B, CMP.B or NEG.B instruction is executed, this flag is set to 1 if there is a carry or borrow at bit 3, and cleared to 0 otherwise. When the ADD.W, SUB.W, CMP.W, or NEG.W instruction is executed, the H flag is set to 1 if there is a carry or borrow at bit 11, and cleared to 0 otherwise. When the ADD.L, SUB.L, CMP.L, or NEG.L instruction is executed, the H flag is set to 1 if there is a carry or borrow at bit 27, and cleared to 0 otherwise.
4	U	Undefined	R/W	User Bit Can be written to and read from by software using the LDC, STC, ANDC, ORC, and XORC instructions.
3	N	Undefined	R/W	Negative Flag Stores the value of the most significant bit of data as a sign bit.
2	Z	Undefined	R/W	Zero Flag Set to 1 to indicate zero data, and cleared to 0 to indicate non-zero data.
1	V	Undefined	R/W	Overflow Flag Set to 1 when an arithmetic overflow occurs, and cleared to 0 otherwise.

Bit	Bit Name	Initial Value	R/W	Description
0	C	Undefined	R/W	Carry Flag Set to 1 when a carry occurs, and cleared to 0 otherwise. Used by: <ul style="list-style-type: none"> • Add instructions, to indicate a carry • Subtract instructions, to indicate a borrow • Shift and rotate instructions, to indicate a carry The carry flag is also used as a bit accumulator by bit manipulation instructions.

2.4.5 Initial Register Values

Reset exception handling loads the CPU's program counter (PC) from the vector table, clears the trace (T) bit in EXR to 0, and sets the interrupt mask (I) bits in CCR and EXR to 1. The other CCR bits and the general registers are not initialized. Note that the stack pointer (ER7) is undefined. The stack pointer should therefore be initialized by an MOV.L instruction executed immediately after a reset.

2.5 Data Formats

The H8S/2000 CPU can process 1-bit, 4-bit BCD, 8-bit (byte), 16-bit (word), and 32-bit (longword) data. Bit-manipulation instructions operate on 1-bit data by accessing bit n ($n = 0, 1, 2, \dots, 7$) of byte operand data. The DAA and DAS decimal-adjust instructions treat byte data as two digits of 4-bit BCD data.

2.5.1 General Register Data Formats

Figure 2.9 shows the data formats of general registers.

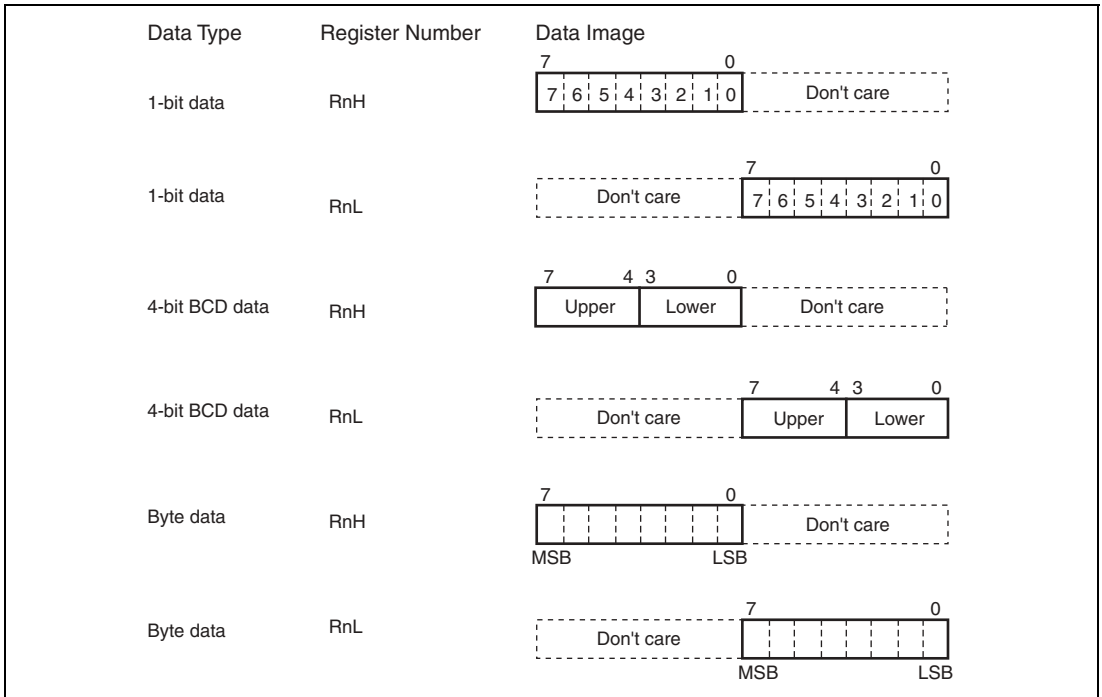
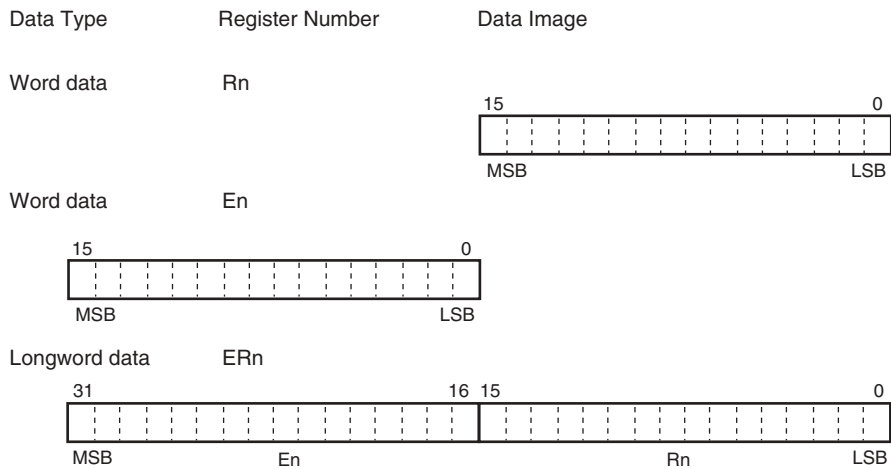

Figure 2.9 General Register Data Formats (1)



[Legend]

ERn: General register ER

En: General register E

Rn: General register R

RnH: General register RH

RnL: General register RL

MSB: Most significant bit

LSB: Least significant bit

Figure 2.9 General Register Data Formats (2)

2.5.2 Memory Data Formats

Figure 2.10 shows the data formats in memory. The H8S/2000 CPU can access word data and longword data in memory, but word or longword data must begin at an even address. If an attempt is made to access word or longword data at an odd address, no address error occurs but the least significant bit of the address is regarded as 0, so the access starts at the preceding address. This also applies to instruction fetches.

When SP (ER7) is used as an address register to access the stack, the operand size should be word size or longword size.

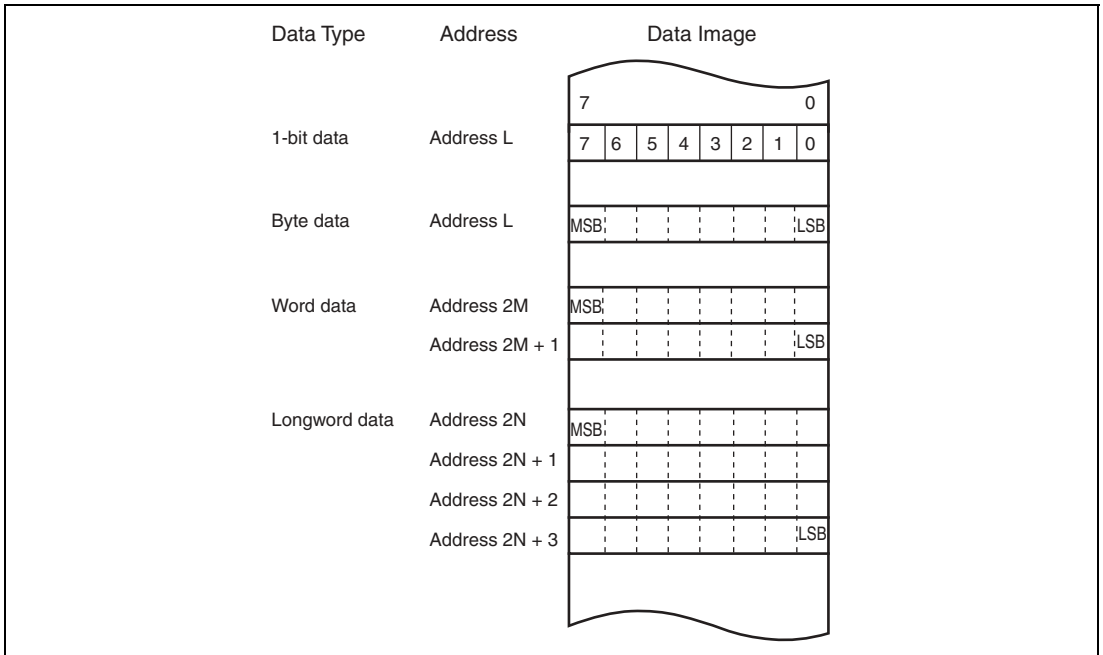

Figure 2.10 Memory Data Formats

2.6 Instruction Set

The H8S/2000 CPU has 65 types of instructions. The instructions are classified by function as shown in table 2.1.

Table 2.1 Instruction Classification

Function	Instructions	Size	Types
Data transfer	MOV	B/W/L	5
	POP* ¹ , PUSH* ¹	W/L	
	LDM, STM* ²	L	
	MOVFP* ³ , MOVTP* ³	B	
Arithmetic operations	ADD, SUB, CMP, NEG	B/W/L	19
	ADDX, SUBX, DAA, DAS	B	
	INC, DEC	B/W/L	
	ADDS, SUBS	L	
	MULXU, DIVXU, MULXS, DIVXS	B/W	
	EXTU, EXTS	W/L	
	TAS	B	
Logic operations	AND, OR, XOR, NOT	B/W/L	4
Shift	SHAL, SHAR, SHLL, SHLR, ROTL, ROTR, ROTXL, ROTXR	B/W/L	8
Bit manipulation	BSET, BCLR, BNOT, BTST, BLD, BILD, BST, BIST, BAND, B BIAND, BOR, BIOR, BXOR, BIXOR	B	14
Branch	B _{cc} * ⁴ , JMP, BSR, JSR, RTS	–	5
System control	TRAPA, RTE, SLEEP, LDC, STC, ANDC, ORC, XORC, NOP	–	9
Block data transfer	EEPMOV	–	1

Total: 65

Notes: B: Byte size; W: Word size; L: Longword size.

1. POP.W Rn and PUSH.W Rn are identical to MOV.W @SP+, Rn and MOV.W Rn, @-SP. POP.L ERn and PUSH.L ERn are identical to MOV.L @SP+, ERn and MOV.L ERn, @-SP.
2. Since register ER7 functions as the stack pointer in an STM/LDM instruction, it cannot be used as an STM/LDM register.
3. Cannot be used in this LSI.
4. B_{cc} is the general name for conditional branch instructions.

2.6.1 Table of Instructions Classified by Function

Tables 2.3 to 2.10 summarize the instructions in each functional category. The notation used in tables 2.3 to 2.10 is defined below.

Table 2.2 Operation Notation

Symbol	Description
Rd	General register (destination)*
Rs	General register (source)*
Rn	General register*
ERn	General register (32-bit register)
(EAd)	Destination operand
(EAs)	Source operand
EXR	Extended control register
CCR	Condition-code register
N	N (negative) flag in CCR
Z	Z (zero) flag in CCR
V	V (overflow) flag in CCR
C	C (carry) flag in CCR
PC	Program counter
SP	Stack pointer
#IMM	Immediate data
disp	Displacement
+	Addition
-	Subtraction
×	Multiplication
÷	Division
^	Logical AND
∨	Logical OR
⊕	Logical exclusive OR
→	Move
~	NOT (logical complement)
:8/:16/:24/:32	8-, 16-, 24-, or 32-bit length

Note: * General registers include 8-bit registers (R0H to R7H, R0L to R7L), 16-bit registers (R0 to R7, E0 to E7), and 32-bit registers (ER0 to ER7).

Table 2.3 Data Transfer Instructions

Instruction	Size*¹	Function
MOV	B/W/L	(EAs) → Rd, Rs → (EAd) Moves data between two general registers or between a general register and memory, or moves immediate data to a general register.
MOVFPE	B	Cannot be used in this LSI.
MOVTPE	B	Cannot be used in this LSI.
POP	W/L	@SP+ → Rn Pops a general register from the stack. POP.W Rn is identical to MOV.W @SP+, Rn. POP.L ERn is identical to MOV.L @SP+, ERn
PUSH	W/L	Rn → @-SP Pushes a general register onto the stack. PUSH.W Rn is identical to MOV.W Rn, @-SP. PUSH.L ERn is identical to MOV.L ERn, @-SP.
LDM* ²	L	@SP+ → Rn (register list) Pops two or more general registers from the stack.
STM* ²	L	Rn (register list) → @-SP Pushes two or more general registers onto the stack.

Notes: 1. Size refers to the operand size.

B: Byte

W: Word

L: Longword

2. Since register ER7 functions as the stack pointer in an STM/LDM instruction, it cannot be used as an STM/LDM register.

Table 2.4 Arithmetic Operations Instructions (1)

Instruction	Size*	Function
ADD SUB	B/W/L	$Rd \pm Rs \rightarrow Rd$, $Rd \pm \#IMM \rightarrow Rd$ Performs addition or subtraction on data in two general registers, or on immediate data and data in a general register. (Subtraction on immediate data and data in a general register cannot be performed in bytes. Use the SUBX or ADD instruction.)
ADDX SUBX	B	$Rd \pm Rs \pm C \rightarrow Rd$, $Rd \pm \#IMM \pm C \rightarrow Rd$ Performs addition or subtraction with carry on data in two general registers, or on immediate data and data in a general register.
INC DEC	B/W/L	$Rd \pm 1 \rightarrow Rd$, $Rd \pm 2 \rightarrow Rd$ Adds or subtracts the value 1 or 2 to or from data in a general register. (Only the value 1 can be added to or subtracted from byte operands.)
ADDS SUBS	L	$Rd \pm 1 \rightarrow Rd$, $Rd \pm 2 \rightarrow Rd$, $Rd \pm 4 \rightarrow Rd$ Adds or subtracts the value 1, 2, or 4 to or from data in a 32-bit register.
DAA DAS	B	Rd (decimal adjust) $\rightarrow Rd$ Decimal-adjusts an addition or subtraction result in a general register by referring to CCR to produce 4-bit BCD data.
MULXU	B/W	$Rd \times Rs \rightarrow Rd$ Performs unsigned multiplication on data in two general registers: either 8-bit \times 8-bit \rightarrow 16-bit or 16-bit \times 16-bit \rightarrow 32-bit.
MULXS	B/W	$Rd \times Rs \rightarrow Rd$ Performs signed multiplication on data in two general registers: either 8-bit \times 8-bit \rightarrow 16-bit or 16-bit \times 16-bit \rightarrow 32-bit.
DIVXU	B/W	$Rd \div Rs \rightarrow Rd$ Performs unsigned division on data in two general registers: either 16-bit \div 8-bit \rightarrow 8-bit quotient and 8-bit remainder or 32-bit \div 16-bit \rightarrow 16-bit quotient and 16-bit remainder.

[Legend]

*: Size refers to the operand size.

B: Byte

W: Word

L: Longword

Table 2.4 Arithmetic Operations Instructions (2)

Instruction	Size*	Function
DIVXS	B/W	Rd ÷ Rs → Rd Performs signed division on data in two general registers: either 16 bits ÷ 8 bits → 8-bit quotient and 8-bit remainder or 32 bits ÷ 16 bits → 16-bit quotient and 16-bit remainder.
CMP	B/W/L	Rd – Rs, Rd – #IMM Compares data in a general register with data in another general register or with immediate data, and sets the CCR bits according to the result.
NEG	B/W/L	0 – Rd → Rd Takes the two's complement (arithmetic complement) of data in a general register.
EXTU	W/L	Rd (zero extension) → Rd Extends the lower 8 bits of a 16-bit register to word size, or the lower 16 bits of a 32-bit register to longword size, by padding with zeros on the left.
EXTS	W/L	Rd (sign extension) → Rd Extends the lower 8 bits of a 16-bit register to word size, or the lower 16 bits of a 32-bit register to longword size, by extending the sign bit.
TAS	B	@ERd – 0, 1 → (<bit 7> of @ERd) Tests memory contents, and sets the most significant bit (bit 7) to 1.

[Legend]

- *: Size refers to the operand size.
- B: Byte
- W: Word
- L: Longword

Table 2.5 Logic Operations Instructions

Instruction	Size*	Function
AND	B/W/L	$Rd \wedge Rs \rightarrow Rd, Rd \wedge \#IMM \rightarrow Rd$ Performs a logical AND operation on a general register and another general register or immediate data.
OR	B/W/L	$Rd \vee Rs \rightarrow Rd, Rd \vee \#IMM \rightarrow Rd$ Performs a logical OR operation on a general register and another general register or immediate data.
XOR	B/W/L	$Rd \oplus Rs \rightarrow Rd, Rd \oplus \#IMM \rightarrow Rd$ Performs a logical exclusive OR operation on a general register and another general register or immediate data.
NOT	B/W/L	$\sim Rd \rightarrow Rd$ Takes the one's complement (logical complement) of data in a general register.

[Legend]

- *: Size refers to the operand size.
- B: Byte
- W: Word
- L: Longword

Table 2.6 Shift Instructions

Instruction	Size*	Function
SHAL	B/W/L	$Rd \text{ (shift)} \rightarrow Rd$
SHAR		Performs an arithmetic shift on data in a general register. 1-bit or 2 bit shift is possible.
SHLL	B/W/L	$Rd \text{ (shift)} \rightarrow Rd$
SHLR		Performs a logical shift on data in a general register. 1-bit or 2 bit shift is possible.
ROTL	B/W/L	$Rd \text{ (rotate)} \rightarrow Rd$
ROTR		Rotates data in a general register. 1-bit or 2 bit rotation is possible.
ROTXL	B/W/L	$Rd \text{ (rotate)} \rightarrow Rd$
ROTXR		Rotates data including the carry flag in a general register. 1-bit or 2 bit rotation is possible.

[Legend]

- *: Size refers to the operand size.
- B: Byte
- W: Word
- L: Longword

Table 2.7 Bit Manipulation Instructions (1)

Instruction	Size*	Function
BSET	B	$1 \rightarrow (\text{<bit-No.> of <EAd>})$ Sets a specified bit in a general register or memory operand to 1. The bit number is specified by 3-bit immediate data or the lower three bits of a general register.
BCLR	B	$0 \rightarrow (\text{<bit-No.> of <EAd>})$ Clears a specified bit in a general register or memory operand to 0. The bit number is specified by 3-bit immediate data or the lower three bits of a general register.
BNOT	B	$\sim (\text{<bit-No.> of <EAd>}) \rightarrow (\text{<bit-No.> of <EAd>})$ Inverts a specified bit in a general register or memory operand. The bit number is specified by 3-bit immediate data or the lower three bits of a general register.
BTST	B	$\sim (\text{<bit-No.> of <EAd>}) \rightarrow Z$ Tests a specified bit in a general register or memory operand and sets or clears the Z flag accordingly. The bit number is specified by 3-bit immediate data or the lower three bits of a general register.
BAND	B	$C \wedge (\text{<bit-No.> of <EAd>}) \rightarrow C$ Logically ANDs the carry flag with a specified bit in a general register or memory operand and stores the result in the carry flag.
BIAND	B	$C \wedge (\sim \text{<bit-No.> of <EAd>}) \rightarrow C$ Logically ANDs the carry flag with the inverse of a specified bit in a general register or memory operand and stores the result in the carry flag. The bit number is specified by 3-bit immediate data.
BOR	B	$C \vee (\text{<bit-No.> of <EAd>}) \rightarrow C$ Logically ORs the carry flag with a specified bit in a general register or memory operand and stores the result in the carry flag.
BIOR	B	$C \vee (\sim \text{<bit-No.> of <EAd>}) \rightarrow C$ Logically ORs the carry flag with the inverse of a specified bit in a general register or memory operand and stores the result in the carry flag. The bit number is specified by 3-bit immediate data.

[Legend]

*: Size refers to the operand size.

B: Byte

Table 2.7 Bit Manipulation Instructions (2)

Instruction	Size*	Function
BXOR	B	$C \oplus (\text{<bit-No.> of <EAd>}) \rightarrow C$ Logically exclusive-ORs the carry flag with a specified bit in a general register or memory operand and stores the result in the carry flag.
BIXOR	B	$C \oplus \sim (\text{<bit-No.> of <EAd>}) \rightarrow C$ Logically exclusive-ORs the carry flag with the inverse of a specified bit in a general register or memory operand and stores the result in the carry flag. The bit number is specified by 3-bit immediate data.
BLD	B	$(\text{<bit-No.> of <EAd>}) \rightarrow C$ Transfers a specified bit in a general register or memory operand to the carry flag.
BILD	B	$\sim (\text{<bit-No.> of <EAd>}) \rightarrow C$ Transfers the inverse of a specified bit in a general register or memory operand to the carry flag. The bit number is specified by 3-bit immediate data.
BST	B	$C \rightarrow (\text{<bit-No.> of <EAd>})$ Transfers the carry flag value to a specified bit in a general register or memory operand.
BIST	B	$\sim C \rightarrow (\text{<bit-No.>. of <EAd>})$ Transfers the inverse of the carry flag value to a specified bit in a general register or memory operand. The bit number is specified by 3-bit immediate data.

[Legend]

*: Size refers to the operand size.

B: Byte

Table 2.8 Branch Instructions

Instruction	Size	Function																																																			
Bcc	–	Branches to a specified address if a specified condition is true. The branching conditions are listed below.																																																			
		<table border="1"> <thead> <tr> <th>Mnemonic</th> <th>Description</th> <th>Condition</th> </tr> </thead> <tbody> <tr> <td>BRA (BT)</td> <td>Always (true)</td> <td>Always</td> </tr> <tr> <td>BRN (BF)</td> <td>Never (false)</td> <td>Never</td> </tr> <tr> <td>BHI</td> <td>High</td> <td>$C \vee Z = 0$</td> </tr> <tr> <td>BLS</td> <td>Low or same</td> <td>$C \vee Z = 1$</td> </tr> <tr> <td>BCC (BHS)</td> <td>Carry clear (high or same)</td> <td>$C = 0$</td> </tr> <tr> <td>BCS (BLO)</td> <td>Carry set (low)</td> <td>$C = 1$</td> </tr> <tr> <td>BNE</td> <td>Not equal</td> <td>$Z = 0$</td> </tr> <tr> <td>BEQ</td> <td>Equal</td> <td>$Z = 1$</td> </tr> <tr> <td>BVC</td> <td>Overflow clear</td> <td>$V = 0$</td> </tr> <tr> <td>BVS</td> <td>Overflow set</td> <td>$V = 1$</td> </tr> <tr> <td>BPL</td> <td>Plus</td> <td>$N = 0$</td> </tr> <tr> <td>BMI</td> <td>Minus</td> <td>$N = 1$</td> </tr> <tr> <td>BGE</td> <td>Greater or equal</td> <td>$N \oplus V = 0$</td> </tr> <tr> <td>BLT</td> <td>Less than</td> <td>$N \oplus V = 1$</td> </tr> <tr> <td>BGT</td> <td>Greater than</td> <td>$Z \vee (N \oplus V) = 0$</td> </tr> <tr> <td>BLE</td> <td>Less or equal</td> <td>$Z \vee (N \oplus V) = 1$</td> </tr> </tbody> </table>	Mnemonic	Description	Condition	BRA (BT)	Always (true)	Always	BRN (BF)	Never (false)	Never	BHI	High	$C \vee Z = 0$	BLS	Low or same	$C \vee Z = 1$	BCC (BHS)	Carry clear (high or same)	$C = 0$	BCS (BLO)	Carry set (low)	$C = 1$	BNE	Not equal	$Z = 0$	BEQ	Equal	$Z = 1$	BVC	Overflow clear	$V = 0$	BVS	Overflow set	$V = 1$	BPL	Plus	$N = 0$	BMI	Minus	$N = 1$	BGE	Greater or equal	$N \oplus V = 0$	BLT	Less than	$N \oplus V = 1$	BGT	Greater than	$Z \vee (N \oplus V) = 0$	BLE	Less or equal	$Z \vee (N \oplus V) = 1$
Mnemonic	Description	Condition																																																			
BRA (BT)	Always (true)	Always																																																			
BRN (BF)	Never (false)	Never																																																			
BHI	High	$C \vee Z = 0$																																																			
BLS	Low or same	$C \vee Z = 1$																																																			
BCC (BHS)	Carry clear (high or same)	$C = 0$																																																			
BCS (BLO)	Carry set (low)	$C = 1$																																																			
BNE	Not equal	$Z = 0$																																																			
BEQ	Equal	$Z = 1$																																																			
BVC	Overflow clear	$V = 0$																																																			
BVS	Overflow set	$V = 1$																																																			
BPL	Plus	$N = 0$																																																			
BMI	Minus	$N = 1$																																																			
BGE	Greater or equal	$N \oplus V = 0$																																																			
BLT	Less than	$N \oplus V = 1$																																																			
BGT	Greater than	$Z \vee (N \oplus V) = 0$																																																			
BLE	Less or equal	$Z \vee (N \oplus V) = 1$																																																			
JMP	–	Branches unconditionally to a specified address.																																																			
BSR	–	Branches to a subroutine at a specified address																																																			
JSR	–	Branches to a subroutine at a specified address																																																			
RTS	–	Returns from a subroutine																																																			

Table 2.9 System Control Instructions

Instruction	Size*	Function
TRAPA	–	Starts trap-instruction exception handling.
RTE	–	Returns from an exception-handling routine.
SLEEP	–	Causes a transition to a power-down state.
LDC	B/W	(EAs) → CCR, (EAs) → EXR Moves the memory operand contents or immediate data to CCR or EXR. Although CCR and EXR are 8-bit registers, word-size transfers are performed between them and memory. The upper eight bits are valid.
STC	B/W	CCR → (EAd), EXR → (EAd) Transfers CCR or EXR contents to a general register or memory operand. Although CCR and EXR are 8-bit registers, word-size transfers are performed between them and memory. The upper eight bits are valid.
ANDC	B	CCR ∧ #IMM → CCR, EXR ∧ #IMM → EXR Logically ANDs the CCR or EXR contents with immediate data.
ORC	B	CCR ∨ #IMM → CCR, EXR ∨ #IMM → EXR Logically ORs the CCR or EXR contents with immediate data.
XORC	B	CCR ⊕ #IMM → CCR, EXR ⊕ #IMM → EXR Logically exclusive-ORs the CCR or EXR contents with immediate data.
NOP	–	PC + 2 → PC Only increments the program counter.

[Legend]

*: Size refers to the operand size.

B: Byte

W: Word

Table 2.10 Block Data Transfer Instructions

Instruction	Size	Function
EEPMOV.B	–	if R4L ≠ 0 then Repeat @ER5+ → @ER6+ R4L–1 → R4L Until R4L = 0 else next:
EEPMOV.W	–	if R4 ≠ 0 then Repeat @ER5+ → @ER6+ R4–1 → R4 Until R4 = 0 else next: Transfers a data block. Starting from the address set in ER5, transfers data for the number of bytes set in R4L or R4 to the address location set in ER6. Execution of the next instruction begins as soon as the transfer is completed.

2.6.2 Basic Instruction Formats

The H8S/2000 CPU instructions consist of 2-byte (1-word) units. An instruction consists of an operation field (op), a register field (r), an effective address extension (EA), and a condition field (cc).

Figure 2.11 shows examples of instruction formats.

- **Operation field**
Indicates the function of the instruction, the addressing mode, and the operation to be carried out on the operand. The operation field always includes the first four bits of the instruction. Some instructions have two operation fields.
- **Register field**
Specifies a general register. Address registers are specified by 3-bit, and data registers by 3-bit or 4-bit. Some instructions have two register fields, and some have no register field.
- **Effective address extension**
8-, 16-, or 32-bit specifying immediate data, an absolute address, or a displacement.
- **Condition field**
Specifies the branching condition of Bcc instructions.

(1) Operation field only



(2) Operation field and register fields

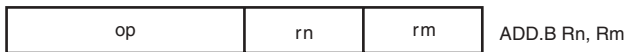

(3) Operation field, register fields, and effective address extension

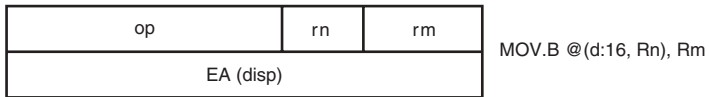

(4) Operation field, effective address extension, and condition field



Figure 2.11 Instruction Formats (Examples)

2.7 Addressing Modes and Effective Address Calculation

The H8S/2000 CPU supports the eight addressing modes listed in table 2.11. Each instruction uses a subset of these addressing modes.

Arithmetic and logic operations instructions can use the register direct and immediate addressing modes. Data transfer instructions can use all addressing modes except program-counter relative and memory indirect. Bit manipulation instructions can use register direct, register indirect, or absolute addressing mode to specify an operand, and register direct (BSET, BCLR, BNOT, and BTST instructions) or immediate (3-bit) addressing mode to specify a bit number in the operand.

Table 2.11 Addressing Modes

No.	Addressing Mode	Symbol
1	Register direct	Rn
2	Register indirect	@ERn
3	Register indirect with displacement	@(d:16,ERn)/@(d:32,ERn)
4	Register indirect with post-increment	@ERn+
	Register indirect with pre-decrement	@-ERn
5	Absolute address	@aa:8/@aa:16/@aa:24/@aa:32
6	Immediate	#xx:8/#xx:16/#xx:32
7	Program-counter relative	@(d:8,PC)/@(d:16,PC)
8	Memory indirect	@@aa:8

2.7.1 Register Direct—Rn

The register field of the instruction code specifies an 8-, 16-, or 32-bit general register which contains the operand. R0H to R7H and R0L to R7L can be specified as 8-bit registers. R0 to R7 and E0 to E7 can be specified as 16-bit registers. ER0 to ER7 can be specified as 32-bit registers.

2.7.2 Register Indirect—@ERn

The register field of the instruction code specifies an address register (ERn) which contains the address of a memory operand. If the address is a program instruction address, the lower 24 bits are valid and the upper eight bits are all assumed to be 0 (H'00).

2.7.3 Register Indirect with Displacement—@(d:16, ERn) or @(d:32, ERn)

A 16-bit or 32-bit displacement contained in the instruction code is added to an address register (ERn) specified by the register field of the instruction, and the sum gives the address of a memory operand. A 16-bit displacement is sign-extended when added.

2.7.4 Register Indirect with Post-Increment or Pre-Decrement—@ERn+ or @-ERn

Register Indirect with Post-Increment—@ERn+: The register field of the instruction code specifies an address register (ERn) which contains the address of a memory operand. After the operand is accessed, 1, 2, or 4 is added to the address register contents and the sum is stored in the address register. The value added is 1 for byte access, 2 for word access, and 4 for longword access. For word or longword transfer instructions, the register value should be even.

Register Indirect with Pre-Decrement—@-ERn: The value 1, 2, or 4 is subtracted from an address register (ERn) specified by the register field in the instruction code, and the result becomes the address of a memory operand. The result is also stored in the address register. The value subtracted is 1 for byte access, 2 for word access, and 4 for longword access. For word or longword transfer instructions, the register value should be even.

2.7.5 Absolute Address—@aa:8, @aa:16, @aa:24, or @aa:32

The instruction code contains the absolute address of a memory operand. The absolute address may be 8 bits long (@aa:8), 16 bits long (@aa:16), 24 bits long (@aa:24), or 32 bits long (@aa:32). Table 2.12 indicates the accessible absolute address ranges.

To access data, the absolute address should be 8 bits (@aa:8), 16 bits (@aa:16), or 32 bits (@aa:32) long. For an 8-bit absolute address, the upper 16 bits are all assumed to be 1 (H'FFFF). For a 16-bit absolute address, the upper 16 bits are a sign extension. For a 32-bit absolute address, the entire address space is accessed.

A 24-bit absolute address (@aa:24) indicates the address of a program instruction. The upper eight bits are all assumed to be 0 (H'00).

Table 2.12 Absolute Address Access Ranges

Absolute Address		Normal Mode*	Advanced Mode
Data address	8 bits (@aa:8)	H'FF00 to H'FFFF	H'FFFF00 to H'FFFFFF
	16 bits (@aa:16)	H'0000 to H'FFFF	H'000000 to H'007FFF, H'FF8000 to H'FFFFFF
	32 bits (@aa:32)		H'000000 to H'FFFFFF
Program instruction address	24 bits (@aa:24)		

Note: * Not available in this LSI.

2.7.6 Immediate—#xx:8, #xx:16, or #xx:32

The 8-bit (#xx:8), 16-bit (#xx:16), or 32-bit (#xx:32) immediate data contained in a instruction code can be used directly as an operand.

The ADDS, SUBS, INC, and DEC instructions implicitly contain immediate data in their instruction codes. Some bit manipulation instructions contain 3-bit immediate data in the instruction code, specifying a bit number. The TRAPA instruction contains 2-bit immediate data in its instruction code, specifying a vector address.

2.7.7 Program-Counter Relative—@(d:8, PC) or @(d:16, PC)

This mode can be used by the Bcc and BSR instructions. An 8-bit or 16-bit displacement contained in the instruction code is sign-extended to 24-bit and added to the 24-bit address indicated by the PC value to generate a 24-bit branch address. Only the lower 24-bit of this branch address are valid; the upper eight bits are all assumed to be 0 (H'00). The PC value to which the displacement is added is the address of the first byte of the next instruction, so the possible branching range is -126 to +128-byte (-63 to +64 words) or -32766 to +32768-byte (-16383 to +16384 words) from the branch instruction. The resulting value should be an even number.

2.7.8 Memory Indirect—@@aa:8

This mode can be used by the JMP and JSR instructions. The instruction code contains an 8-bit absolute address specifying a memory operand which contains a branch address. The upper bits of the 8-bit absolute address are all assumed to be 0, so the address range is 0 to 255 (H'0000 to H'00FF in normal mode*, H'000000 to H'0000FF in advanced mode).

In normal mode*, the memory operand is a word operand and the branch address is 16 bits long. In advanced mode, the memory operand is a longword operand, the first byte of which is assumed to be 0 (H'00).

Note that the top area of the address range in which the branch address is stored is also used for the exception vector area. For further details, see section 4, Exception Handling.

If an odd address is specified in word or longword memory access, or as a branch address, the least significant bit is regarded as 0, causing data to be accessed or the instruction code to be fetched at the address preceding the specified address. (For further information, see section 2.5.2, Memory Data Formats.)

Note: * Not available in this LSI.

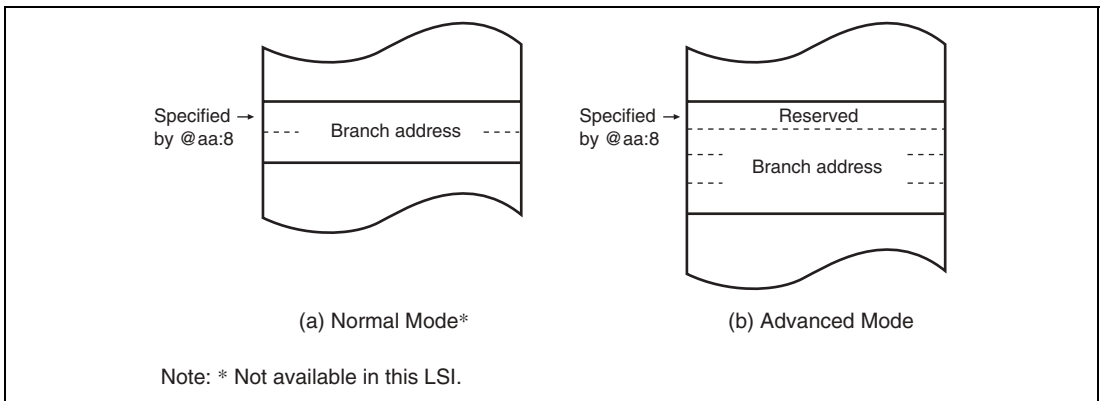

Figure 2.12 Branch Address Specification in Memory Indirect Addressing Mode

2.7.9 Effective Address Calculation

Table 2.13 indicates how effective addresses are calculated in each addressing mode. In normal mode*, the upper eight bits of the effective address are ignored in order to generate a 16-bit address.

Note * Not available in this LSI.

Table 2.13 Effective Address Calculation (1)











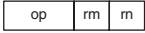

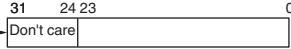

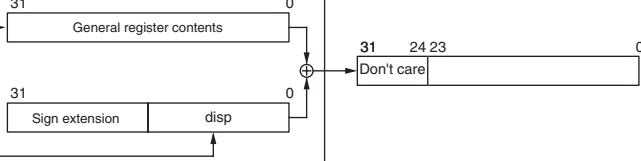
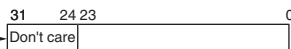

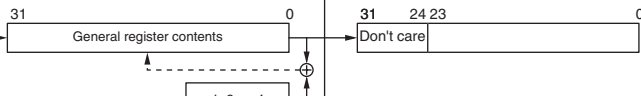
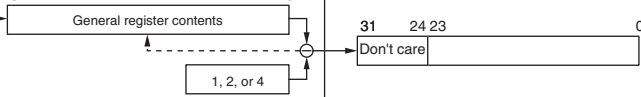
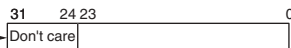
No	Addressing Mode and Instruction Format	Effective Address Calculation	Effective Address (EA)								
1	Register direct (Rn) 		Operand is general register contents.								
2	Register indirect (@ERn) 										
3	Register indirect with displacement @(d:16,ERn) or @(d:32,ERn) 										
4	Register indirect with post-increment or pre-decrement • Register indirect with post-increment @ERn+  • Register indirect with pre-decrement @-ERn 	  <table border="1" data-bbox="475 1021 716 1101"> <thead> <tr> <th>Operand Size</th> <th>Offset</th> </tr> </thead> <tbody> <tr> <td>Byte</td> <td>1</td> </tr> <tr> <td>Word</td> <td>2</td> </tr> <tr> <td>Longword</td> <td>4</td> </tr> </tbody> </table>	Operand Size	Offset	Byte	1	Word	2	Longword	4	 
Operand Size	Offset										
Byte	1										
Word	2										
Longword	4										

Table 2.13 Effective Address Calculation (2)

No	Addressing Mode and Instruction Format	Effective Address Calculation	Effective Address (EA)
5	<p>Absolute address</p> <p>@aa:8</p>  <p>@aa:16</p>  <p>@aa:24</p>  <p>@aa:32</p> 		
6	<p>Immediate</p> <p>#xx:8/#xx:16/#xx:32</p> 		<p>Operand is immediate data.</p>
7	<p>Program-counter relative</p> <p>@(d:8,PC)/@(d:16,PC)</p> 		
8	<p>Memory indirect @aa:8</p> <ul style="list-style-type: none"> Normal mode*  <ul style="list-style-type: none"> Advanced mode 		

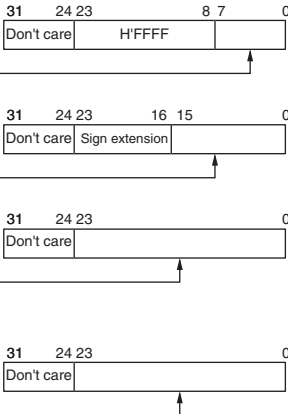
Note: * Not available in this LSI.

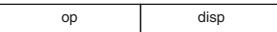
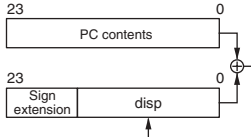
2.8 Processing States

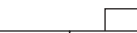
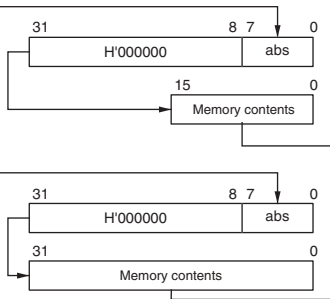
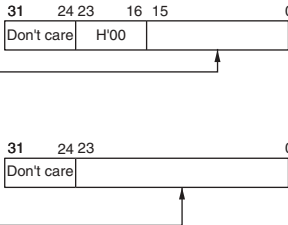
The H8S/2000 CPU has five main processing states: the reset state, exception handling state, program execution state, bus-released state, and program stop state. Figure 2.13 indicates the state transitions.

- **Reset state**

In this state the CPU and on-chip peripheral modules are all initialized and stopped. When the $\overline{\text{RES}}$ input goes low, all current processing stops and the CPU enters the reset state. All interrupts are masked in the reset state. Reset exception handling starts when the $\overline{\text{RES}}$ signal changes from low to high. For details, see section 4, Exception Handling.

The reset state can also be entered by a watchdog timer overflow.
- **Exception-handling state**

The exception-handling state is a transient state that occurs when the CPU alters the normal processing flow due to an exception source, such as, a reset, trace, interrupt, or trap instruction. The CPU fetches a start address (vector) from the exception vector table and branches to that address. For further details, see section 4, Exception Handling.
- **Program execution state**

In this state the CPU executes program instructions in sequence.
- **Bus-released state**

In a product which has a bus master other than the CPU, such as a data transfer controller (DTC), the bus-released state occurs when the bus has been released in response to a bus request from a bus master other than the CPU. While the bus is released, the CPU halts operations.
- **Program stop state**

This is a power-down state in which the CPU stops operating. The program stop state occurs when a SLEEP instruction is executed or the CPU enters hardware standby mode. For details, see section 23, Power-Down Modes.

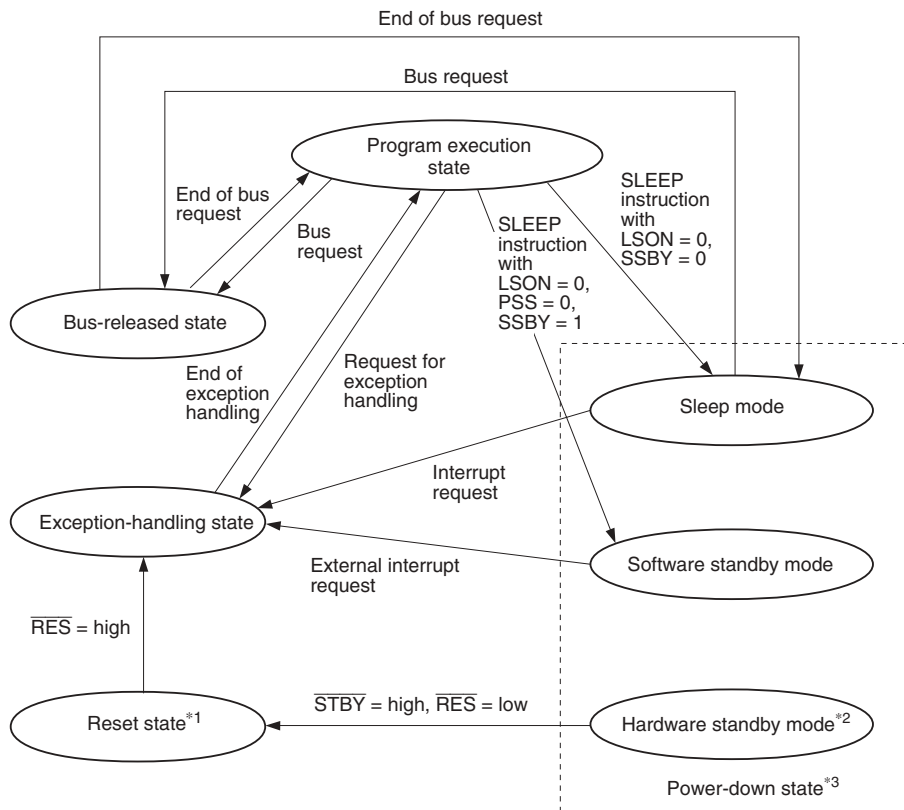

- Notes:
1. From any state except hardware standby mode, a transition to the reset state occurs whenever \overline{RES} goes low. A transition can also be made to the reset state when the watchdog timer overflows.
 2. From any state, a transition to hardware standby mode occurs when \overline{STBY} goes low.
 3. The power-down state also includes watch mode, subactive mode, subsleep mode, etc. For details, refer to section 23, Power-Down Modes.

Figure 2.13 State Transitions

2.9 Usage Notes

2.9.1 Note on TAS Instruction Usage

The TAS instruction is not generated by the Renesas H8S and H8/300 series C/C++ compilers. The TAS instruction can be used as a user-defined intrinsic function.

2.9.2 Note on Bit Manipulation Instructions

The BSET, BCLR, BNOT, BST, and BIST instructions read data in byte units, manipulate the data of the target bit, and write data in byte units. Special care is required when using these instructions in cases where a register containing a write-only bit is used or a bit is directly manipulated for a port.

In addition, the BCLR instruction can be used to clear the flag of the internal I/O register. In this case, if the flag to be cleared has been set to 1 by an interrupt processing routine, the flag need not be read before executing the BCLR instruction.

2.9.3 EEPMOV Instruction

1. EEPMOV is a block-transfer instruction and transfers the byte size of data indicated by R4*, which starts from the address indicated by ER5, to the address indicated by ER6.

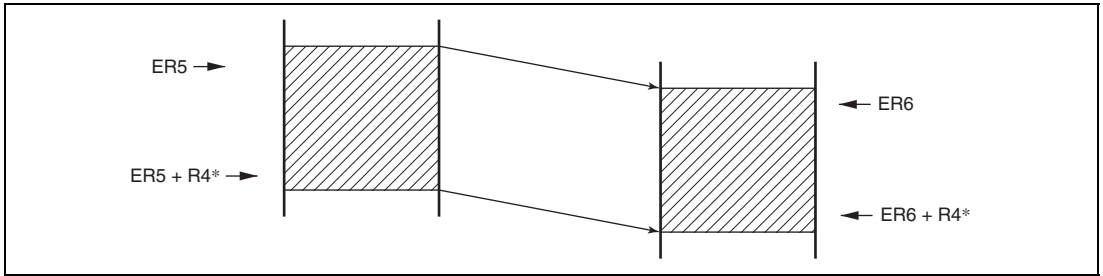

2. Set R4* and ER6 so that the end address of the destination address (value of ER6 + R4*) does not exceed H'00FFFFFF (the value of ER6 must not change from H'00FFFFFFF to H'01000000 during execution).

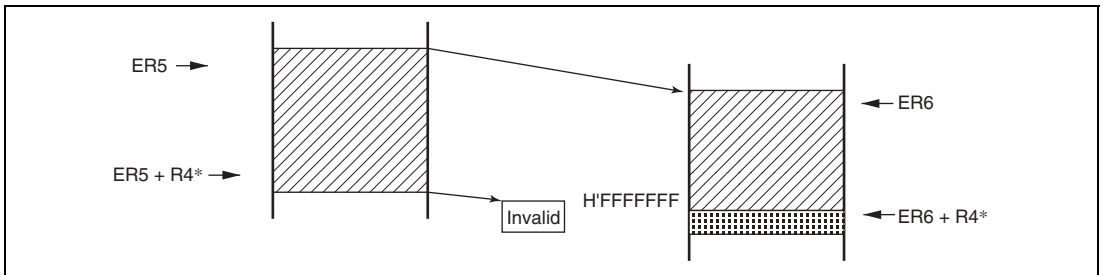

Note: * For byte transfer R4L is used.

Section 3 MCU Operating Modes

3.1 Operating Mode Selection

This LSI supports one operating mode (mode 2). The operating mode is determined by the setting of the mode pins ($\overline{\text{MD2}}$, MD1, and MD0). Table 3.1 shows the MCU operating mode selection.

Table 3.1 MCU Operating Mode Selection

MCU Operating Mode	$\overline{\text{MD2}}$	MD1	MD0	CPU Operating Mode	Description
2	1	1	0	Advanced	Extended mode with on-chip ROM Single-chip mode

Mode 2 is single-chip mode after a reset. The CPU can switch to extended mode by setting bit EXPE in MDCR to 1.

Modes 0, 1, 3, 5, and 7 are not available in this LSI. Modes 4 and 6 are operating mode for a special purpose. Thus, mode pins should be set to enable mode 2 in normal program execution state. Mode pins should not be changed during operation.

3.2 Register Descriptions

The following registers are related to the operating mode. For details on the bus control register (BCR), see section 6.3.1, Bus Control Register (BCR), and for details on bus control register 2 (BCR2), see section 6.3.2, Bus Control Register 2 (BCR2).

- Mode control register (MDCR)
- System control register (SYSCR)
- Serial timer control register (STCR)

3.2.1 Mode Control Register (MDCR)

MDCR is used to set an operating mode and to monitor the current operating mode.

Bit	Bit Name	Initial Value	R/W	Description
7	EXPE	0	R/W	Extended Mode Enable Specifies extended mode. 0: Single-chip mode 1: Extended mode
6 to 3	—	All 0	R	Reserved
2	MDS2	—*	R	Mode Select 2 to 0
1	MDS1	—*	R	These bits indicate the input levels at mode pins ($\overline{MD2}$, MD1, and MD0) (the current operating mode). Bits MDS2, MDS1, and MDS0 correspond to $\overline{MD2}$, MD1, and MD0, respectively. MDS2 to MDS0 are read-only bits and they cannot be written to. The mode pin ($\overline{MD2}$, MD1, and MD0) input levels are latched into these bits when MDCR is read. These latches are canceled by a reset.
0	MDS0	—*	R	

Note: * The initial values are determined by the settings of the $\overline{MD2}$, MD1, and MD0 pins.

3.2.2 System Control Register (SYSCR)

SYSCR selects a system pin function, monitors a reset source, selects the interrupt control mode and the detection edge for NMI, enables or disables register access to the on-chip peripheral modules, and enables or disables on-chip RAM address space.

Bit	Bit Name	Initial Value	R/W	Description
7	CS256E	0	R/W	<p>Chip Select 256 Enable</p> <p>Enables or disables P97/$\overline{\text{WAIT}}$/$\overline{\text{CS256}}$ pin function in extended mode.</p> <p>0: P97/$\overline{\text{WAIT}}$ pin $\overline{\text{WAIT}}$ pin function is selected by the settings of WSCR and WSCR2.</p> <p>1: $\overline{\text{CS256}}$ pin Outputs low when a 256-kbyte expansion area of addresses H'F80000 to H'FBFFFF is accessed.</p>
6	IOSE	0	R/W	<p>IOS Enable</p> <p>Enables or disables $\overline{\text{AS}}$/$\overline{\text{IOS}}$ pin function in extended mode.</p> <p>0: $\overline{\text{AS}}$ pin Outputs low when an external area is accessed.</p> <p>1: $\overline{\text{IOS}}$ pin Outputs low when an IOS expansion area of addresses H'FFF000 to H'FFF7FF is accessed.</p>
5	INTM1	0	R	<p>These bits select the control mode of the interrupt controller. For details on the interrupt control modes, see section 5.6, Interrupt Control Modes and Interrupt Operation.</p> <p>00: Interrupt control mode 0 01: Interrupt control mode 1 10: Setting prohibited 11: Setting prohibited</p>
4	INTM0	0	R/W	
3	XRST	1	R	<p>External Reset</p> <p>This bit indicates the reset source. A reset is caused by an external reset input, or when the watchdog timer overflows.</p> <p>0: A reset is caused when the watchdog timer overflows. 1: A reset is caused by an external reset.</p>
2	NMIEG	0	R/W	<p>NMI Edge Select</p> <p>Selects the valid edge of the NMI interrupt input.</p> <p>0: An interrupt is requested at the falling edge of NMI input 1: An interrupt is requested at the rising edge of NMI input</p>

Bit	Bit Name	Initial Value	R/W	Description
1	KINWUE	0	R/W	<p>Keyboard Control Register Access Enable</p> <p>Enables or disables CPU access for input control registers (KMIMRA, KMIMR6, WUEMR3) of \overline{KINn} and \overline{WUEn} pins, input pull-up MOS control register (KMPCR6) of the \overline{KINn} pin, and registers (TCR_X/TCR_Y, TCSR_X/TCSR_Y, TICRR/TCORA_Y, TICRF/TCORB_Y, TCNT_X/TCNT_Y, TCORC/TISR, TCORA_X, TCORB_X) of 8-bit timers (TMR_X, TMR_Y).</p> <p>0: Enables CPU access for registers of TMR_X and TMR_Y in an area from H'FFFFFF0 to H'FFFFFF7 and from H'FFFFFFC to H'FFFFFFF.</p> <p>1: Enables CPU access for input control registers of the \overline{KINn} and \overline{WUEn} pins and the input pull-up MOS control register of the \overline{KINn} pin in an area from H'FFFFFF0 to H'FFFFFF7 and from H'FFFFFFC to H'FFFFFFF.</p>
0	RAME	1	R/W	<p>RAM Enable</p> <p>Enables or disables on-chip RAM. The RAME bit is initialized when the reset state is released.</p> <p>0: On-chip RAM is disabled</p> <p>1: On-chip RAM is enabled</p>

3.2.3 Serial Timer Control Register (STCR)

STCR enables or disables register access, IIC operating mode, and on-chip flash memory, and selects the input clock of the timer counter.

Bit	Bit Name	Initial Value	R/W	Description
7	IICX2	0	R/W	IIC Transfer Rate Select 2, 1 and 0
6	IICX1	0	R/W	These bits control the IIC operation. These bits select a transfer rate in master mode together with bits CKS2 to CKS0 in the I ² C bus mode register (ICMR). For details on the transfer rate, see table 15.3. The IICXn bit controls IIC_n. (n = 0 to 2)
5	IICX0	0	R/W	

Bit	Bit Name	Initial Value	R/W	Description
4	IICE	0	R/W	<p>IIC Master Enable</p> <p>Enables or disables CPU access for IIC registers (ICCR, ICSR, ICDR/SARX, ICMR/SAR), PWMX registers (DADRAH/DACR, DADRAL, DADRBH/DACNTH, DADRBL/DACNTL), and SCI registers (SMR, BRR, SCMR).</p> <p>0: SCI_1 registers are accessed in an area from H'FFFF88 to H'FFFF89 and from H'FFFF8E to H'FFFF8F.</p> <p>SCI_2 registers are accessed in an area from H'FFFFA0 to H'FFFFA1 and from H'FFFFA6 to H'FFFFA7.</p> <p>SCI_0 registers are accessed in an area from H'FFFFD8 to H'FFFFD9 and from H'FFFFDE to H'FFFFDF.</p> <p>1: IIC_1 registers are accessed in an area from H'FFFF88 to H'FFFF89 and from H'FFFF8E to H'FFFF8F.</p> <p>PWMX registers are accessed in an area from H'FFFFA0 to H'FFFFA1 and from H'FFFFA6 to H'FFFFA7.</p> <p>IIC_0 registers are accessed in an area from H'FFFFD8 to H'FFFFD9 and from H'FFFFDE to H'FFFFDF.</p>
3	FLSHE	0	R/W	<p>Flash Memory Control Register Enable</p> <p>Enables or disables CPU access for flash memory registers (FCCS, FPCS, FECS, FKEY, FMATS, FTDAR), control registers of power-down states (SBYCR, LPWRCR, MSTPCRH, MSTPCRL), and control registers of on-chip peripheral modules (BCR2, WSCR2, PCSR, SYSCR2).</p> <p>0: Area from H'FFFE88 to H'FFFE8F is reserved.</p> <p>Control registers of power-down states and on-chip peripheral modules are accessed in an area from H'FFFF80 to H'FFFF87.</p> <p>1: Control registers of flash memory are accessed in an area from H'FFFE88 to H'FFFE8F.</p> <p>Area from H'FFFF80 to H'FFFF87 is reserved.</p>
2	—	0	R/W	<p>Reserved</p> <p>The initial value should not be changed.</p>
1	ICKS1	0	R/W	Internal Clock Source Select 1, 0
0	ICKS0	0	R/W	<p>These bits select a clock to be input to the timer counter (TCNT) and a count condition together with bits CKS2 to CKS0 in the timer control register (TCR). For details, see section 12.3.4, Timer Control Register (TCR).</p>

3.3 Operating Mode Descriptions

3.3.1 Mode 2

The CPU can access a 16 Mbytes address space in advanced mode. The on-chip ROM is enabled.

After a reset, the LSI is set to single-chip mode. To access an external address space, bit EXPE in MDCR should be set to 1.

Normal extended mode:

In extended modes, ports 1 and 2 function as input ports after a reset.

Ports 1 and 2 function as an address bus by setting 1 to the corresponding port data direction register (DDR). Port 3 functions as a data bus port, and parts of port 9 carry bus control signals.

Port 6 functions as a data bus port when the ABW bit in WSCR is cleared to 0.

Multiplex extended mode:

When 8-bit bus is specified, port 2 functions as the port for address output and data input/output regardless of the setting of the data direction register (DDR). Port 1 can be used as a general port.

When 16-bit bus is specified, ports 1 and 2 function as the port for address output and data input/output regardless of the setting of the data direction register (DDR).

3.3.2 Pin Functions in Each Operating Mode

Pin functions of ports 1 to 3, 6, 9, and A depend on the extended mode. Table 3.2 shows pin functions in each operating mode.

Table 3.2 Pin Functions in Each Mode

Port		Mode 2	
		Normal extension	Multiplex extension
Port 1		I/O port* or Address bus output	I/O port* or Address/Data multiplex I/O
Port 2		I/O port* or Address bus output	I/O port* or Address/Data multiplex I/O
Port 3		I/O port* or Data bus I/O	I/O port*
Port 6		I/O port* or Data bus I/O	I/O port*
Port 9	I/O port97	I/O port* or Control signal output	I/O port* or Control signal output
	I/O port96	Input port* or Clock I/O	Input port* or Clock I/O
	I/O port95 to I/O port93	I/O port* or Control signal output	I/O port* or Control signal output
	I/O port92	I/O port* or Control signal output	I/O port* or Control signal output
	I/O port91	I/O port* or Control signal output	I/O port* or Control signal output
	I/O port90	I/O port* or Control signal output	I/O port* or Control signal output
Port A		I/O port* or Address bus output	I/O port*

[Legend]

*: After reset

3.4 Address Map

Figures 3.1 to 3.3 show memory maps in operating mode.

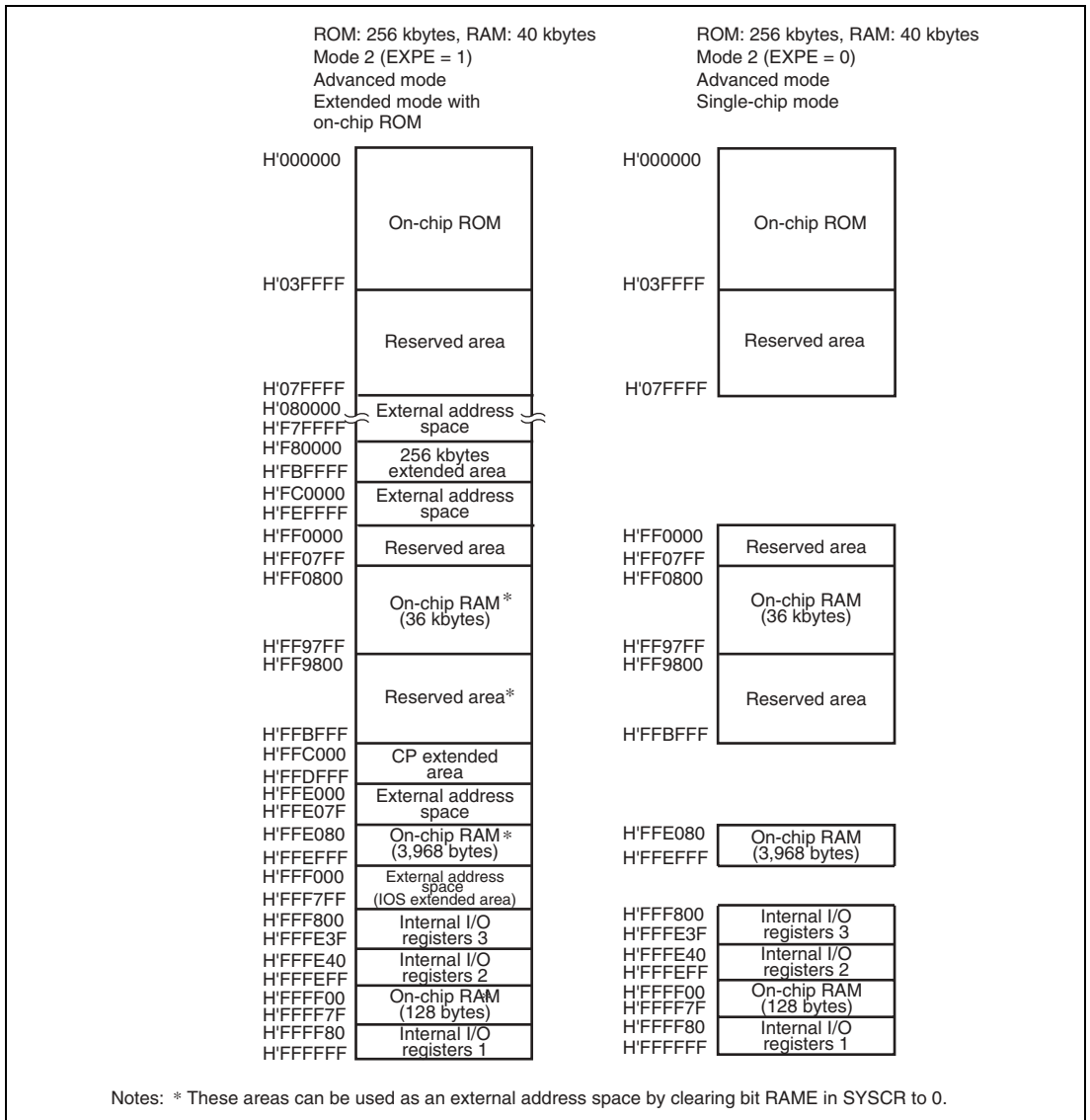
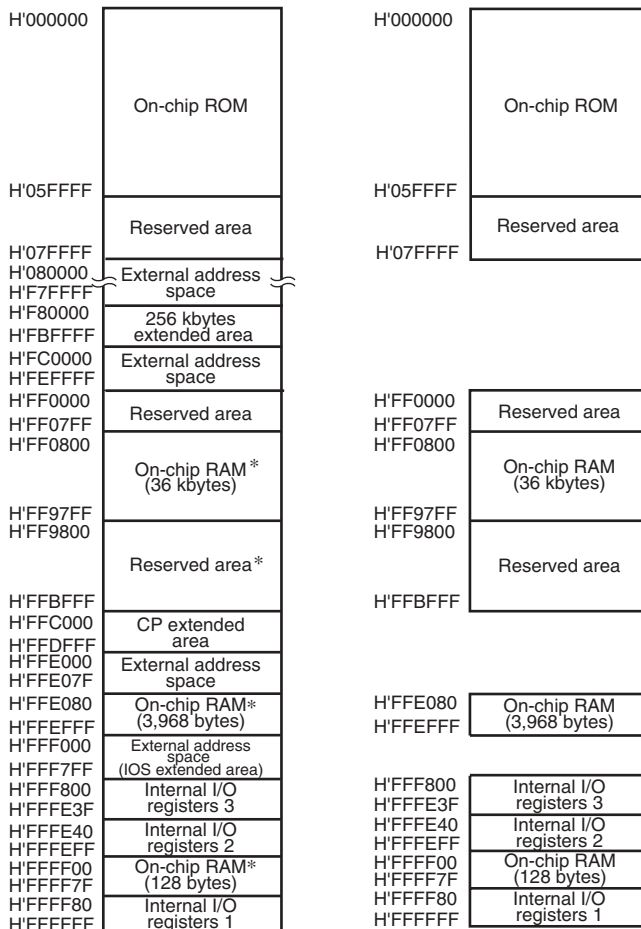

Figure 3.1 H8S/2168 Address Map

ROM: 384 kbytes, RAM: 40 kbytes
 Mode 2 (EXPE = 1)
 Advanced mode
 Extended mode with
 on-chip ROM

ROM: 384 kbytes, RAM: 40 kbytes
 Mode 2 (EXPE = 0)
 Advanced mode
 Single-chip mode



Notes: * These areas can be used as an external address space by clearing bit RAME in SYSCR to 0.

Figure 3.2 H8S/2167 Address Map

ROM: 512 kbytes, RAM: 40 kbytes
 Mode 2 (EXPE = 1)
 Advanced mode
 Extended mode with
 on-chip ROM

ROM: 512 kbytes, RAM: 40 kbytes
 Mode 2 (EXPE = 0)
 Advanced mode
 Single-chip mode

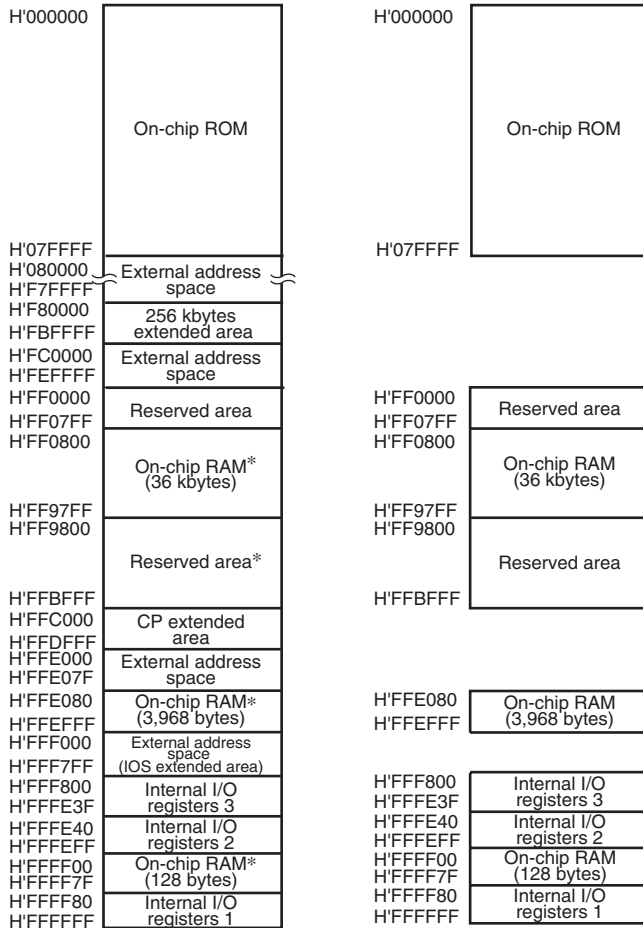

Notes: * These areas can be used as an external address space by clearing bit RAME in SYSCR to 0.

Figure 3.3 H8S/2166 Address Map

Section 4 Exception Handling

4.1 Exception Handling Types and Priority

As table 4.1 indicates, exception handling may be caused by a reset, interrupt, direct transition, or trap instruction. Exception handling is prioritized as shown in table 4.1. If two or more exceptions occur simultaneously, they are accepted and processed in order of priority.

Table 4.1 Exception Types and Priority

Priority	Exception Type	Start of Exception Handling
High ↑ Low	Reset	Starts immediately after a low-to-high transition of the $\overline{\text{RES}}$ pin, or when the watchdog timer overflows.
	Interrupt	Starts when execution of the current instruction or exception handling ends, if an interrupt request has been issued. Interrupt detection is not performed on completion of ANDC, ORC, XORC, or LDC instruction execution, or on completion of reset exception handling.
	Direct transition	Starts when a direct transition occurs as the result of SLEEP instruction execution.
	Trap instruction	Started by execution of a trap (TRAPA) instruction. Trap instruction exception handling requests are accepted at all times in program execution state.

4.2 Exception Sources and Exception Vector Table

Different vector addresses are assigned to different exception sources. Table 4.2 lists the exception sources and their vector addresses.

Table 4.2 Exception Handling Vector Table

Exception Source	Vector Number	Vector Address
		Advanced Mode
Reset	0	H'000000 to H'000003
Reserved for system use	1	H'000004 to H'000007
	5	H'000014 to H'000017
Direct transition	6	H'000018 to H'00001B
External interrupt (NMI)	7	H'00001C to H'00001F
Trap instruction (four sources)	8	H'000020 to H'000023
	9	H'000024 to H'000027
	10	H'000028 to H'00002B
	11	H'00002C to H'00002F
Direct transition (clock switchover)	12	H'000030 to H'000033
Reserved for system use	13	H'000034 to H'000037
	15	H'00003C to H'00003F
External interrupt	IRQ0	H'000040 to H'000043
	IRQ1	H'000044 to H'000047
	IRQ2	H'000048 to H'00004B
	IRQ3	H'00004C to H'00004F
	IRQ4	H'000050 to H'000053
	IRQ5	H'000054 to H'000057
	IRQ6	H'000058 to H'00005B
	IRQ7	H'00005C to H'00005F
Internal interrupt*	24	H'000060 to H'000063
	29	H'000074 to H'000077
External interrupt	KIN7 to KIN0	H'000078 to H'00007B
	KIN15 to KIN8	H'00007C to H'00007F
	Reserved	H'000080 to H'000083
	WUE15 to WUE8	H'000084 to H'000087

Table 4.2 Exception Handling Vector Table (cont)

Exception Source	Vector Number	Vector Address
		Advanced Mode
Internal interrupt*	34	H'000088 to H'00008B
	55	H'0000DC to H'0000DF
External interrupt	IRQ8	H'0000E0 to H'0000E3
	IRQ9	H'0000E4 to H'0000E7
	IRQ10	H'0000E8 to H'0000EB
	IRQ11	H'0000EC to H'0000EF
	IRQ12	H'0000F0 to H'0000F3
	IRQ13	H'0000F4 to H'0000F7
	IRQ14	H'0000F8 to H'0000FB
	IRQ15	H'0000FC to H'0000FF
Internal interrupt*	64	H'000100 to H'000103
	119	H'0001DC to H'0001DF

Note: * For details on the internal interrupt vector table, see section 5.5, Interrupt Exception Handling Vector Table.

4.3 Reset

A reset has the highest exception priority. When the $\overline{\text{RES}}$ pin goes low, all processing halts and this LSI enters the reset. To ensure that this LSI is reset, hold the $\overline{\text{RES}}$ pin low for at least 20 ms at power-on. To reset the chip during operation, hold the $\overline{\text{RES}}$ pin low for at least 20 states. A reset initializes the internal state of the CPU and the registers of on-chip peripheral modules. The chip can also be reset by overflow of the watchdog timer. For details, see section 13, Watchdog Timer (WDT).

4.3.1 Reset Exception Handling

When the $\overline{\text{RES}}$ pin goes high after being held low for the necessary time, this LSI starts reset exception handling as follows:

1. The internal state of the CPU and the registers of the on-chip peripheral modules are initialized and the I bit in CCR is set to 1.
2. The reset exception handling vector address is read and transferred to the PC, and program execution starts from the address indicated by the PC.

Figure 4.1 shows an example of the reset sequence.

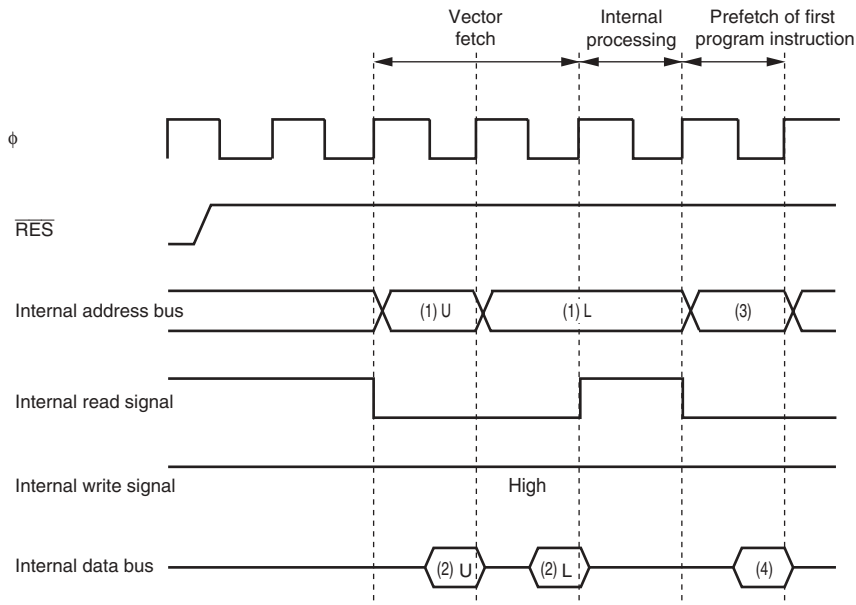

- (1) Reset exception handling vector address (1) U = H'000000 (1) L = H'000002
 (2) Start address (contents of reset exception handling vector address)
 (3) Start address ((3) = (2)U + (2)L)
 (4) First program instruction

Figure 4.1 Reset Sequence

4.3.2 Interrupts after Reset

If an interrupt is accepted after a reset and before the stack pointer (SP) is initialized, the PC and CCR will not be saved correctly, leading to a program crash. To prevent this, all interrupt requests, including NMI, are disabled immediately after a reset. Since the first instruction of a program is always executed immediately after the reset state ends, make sure that this instruction initializes the stack pointer (example: `MOV.L #xx: 32, SP`).

4.3.3 On-Chip Peripheral Modules after Reset is Cancelled

After a reset is cancelled, the module stop control registers (MSTPCR, MSTPCRA, SUBMSTPB, and SUBMSTPA) are initialized, and all modules except the DTC operate in module stop mode. Therefore, the registers of on-chip peripheral modules cannot be read from or written to. To read from and write to these registers, clear module stop mode.

4.4 Interrupt Exception Handling

Interrupts are controlled by the interrupt controller. The sources to start interrupt exception handling are external interrupt sources (NMI, IRQ15 to IRQ0, KIN15 to KIN0, and WUE15 to WUE8) and internal interrupt sources from the on-chip peripheral modules. NMI is an interrupt with the highest priority. For details, see section 5, Interrupt Controller.

Interrupt exception handling is conducted as follows:

1. The values in the program counter (PC) and condition code register (CCR) are saved to the stack.
2. A vector address corresponding to the interrupt source is generated, the start address is loaded from the vector table to the PC, and program execution begins from that address.

4.5 Trap Instruction Exception Handling

Trap instruction exception handling starts when a TRAPA instruction is executed. Trap instruction exception handling can be executed at all times in the program execution state.

Trap instruction exception handling is conducted as follows:

1. The values in the program counter (PC) and condition code register (CCR) are saved to the stack.
2. A vector address corresponding to the interrupt source is generated, the start address is loaded from the vector table to the PC, and program execution starts from that address.

The TRAPA instruction fetches a start address from a vector table entry corresponding to a vector number from 0 to 3, as specified in the instruction code.

Table 4.3 shows the status of CCR after execution of trap instruction exception handling.

Table 4.3 Status of CCR after Trap Instruction Exception Handling

Interrupt Control Mode	CCR	
	I	UI
0	Set to 1	Retains value prior to execution
1	Set to 1	Set to 1

4.6 Stack Status after Exception Handling

Figure 4.2 shows the stack after completion of trap instruction exception handling and interrupt exception handling.

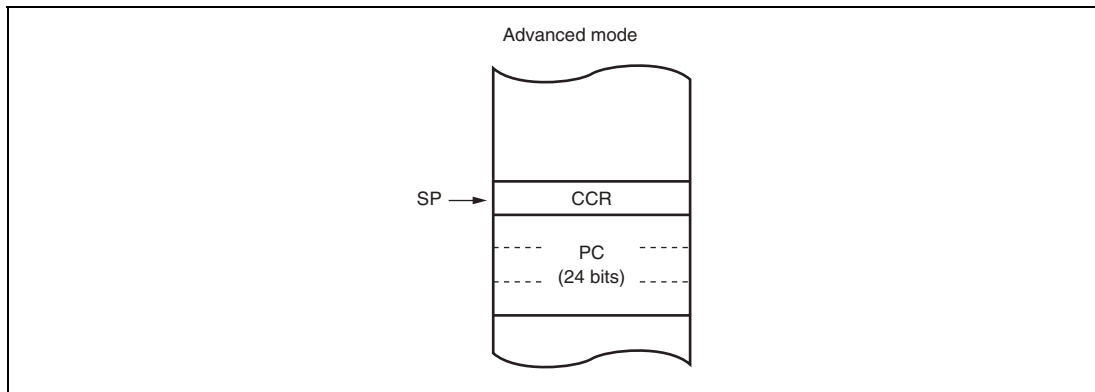

Figure 4.2 Stack Status after Exception Handling

4.7 Usage Note

When accessing word data or longword data, this LSI assumes that the lowest address bit is 0. The stack should always be accessed in words or longwords, and the value of the stack pointer (SP: ER7) should always be kept even.

Use the following instructions to save registers:

```
PUSH.W   Rn    (or MOV.W Rn, @-SP)
PUSH.L   ERn   (or MOV.L ERn, @-SP)
```

Use the following instructions to restore registers:

```
POP.W    Rn    (or MOV.W @SP+, Rn)
POP.L    ERn   (or MOV.L @SP+, ERn)
```

Setting SP to an odd value may lead to a malfunction. Figure 4.3 shows an example of what happens when the SP value is odd.

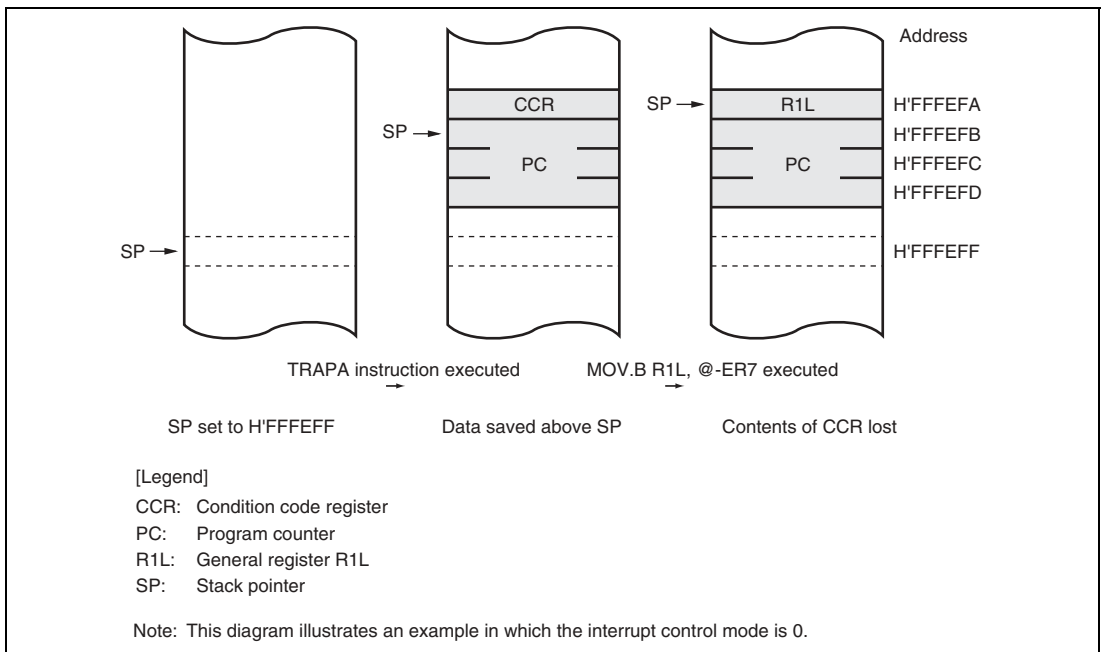
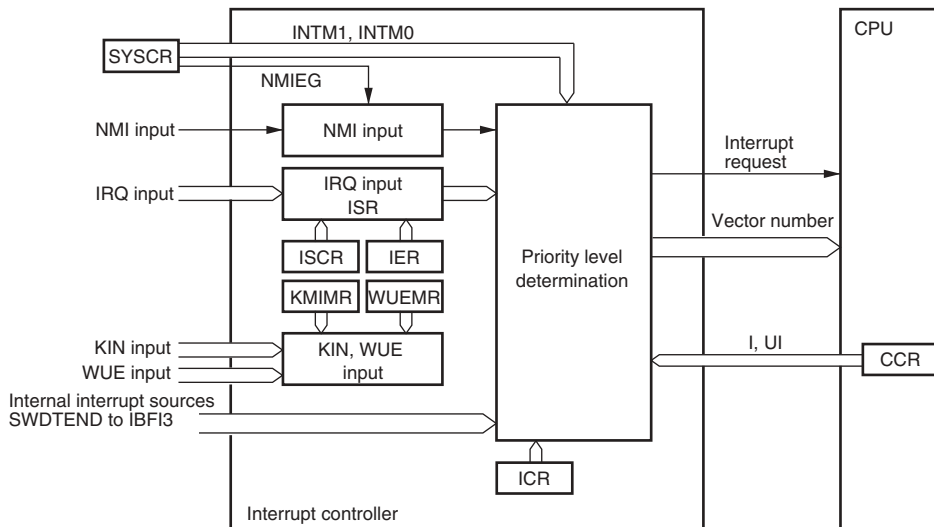

Figure 4.3 Operation when SP Value Is Odd

Section 5 Interrupt Controller

5.1 Features

- Two interrupt control modes
Any of two interrupt control modes can be set by means of the INTM1 and INTM0 bits in the system control register (SYSCR).
- Priorities settable with ICR
An interrupt control register (ICR) is provided for setting interrupt priorities. Priority levels can be set for each module for all interrupts except NMI, KIN, and WUE.
- Three-level interrupt mask control
By means of the interrupt control mode, I and UI bits in CCR, and ICR, 3-level interrupt mask control is performed.
- Independent vector addresses
All interrupt sources are assigned independent vector addresses, making it unnecessary for the source to be identified in the interrupt handling routine.
- Forty-one external interrupts
NMI is the highest-priority interrupt, and is accepted at all times. Rising edge or falling edge detection can be selected for NMI. Falling-edge, rising-edge, or both-edge detection, or level sensing, can be selected for $\overline{\text{IRQ}}_{15}$ to $\overline{\text{IRQ}}_0$. An interrupt is requested at the falling edge for $\overline{\text{KIN}}_{15}$ to $\overline{\text{KIN}}_0$ and $\overline{\text{WUE}}_{15}$ to $\overline{\text{WUE}}_8$.
- DTC control
The DTC can be activated by an interrupt request.



[Legend]

- ICR: Interrupt control register
- ISCR: IRQ sense control register
- IER: IRQ enable register
- ISR: IRQ status register
- KMIMR: Keyboard matrix interrupt mask register
- WUEMR: Wake-up event interrupt mask register
- SYSCR: System control register

Figure 5.1 Block Diagram of Interrupt Controller

5.2 Input/Output Pins

Table 5.1 summarizes the pins of the interrupt controller.

Table 5.1 Pin Configuration

Symbol	I/O	Function
NMI	Input	Nonmaskable external interrupt Rising edge or falling edge can be selected
$\overline{\text{IRQ15}}$ to $\overline{\text{IRQ0}}$ $\overline{\text{ExIRQ15}}$ to $\overline{\text{ExIRQ2}}$	Input	Maskable external interrupts Rising edge, falling edge, or both edges, or level sensing, can be selected individually for each pin. Pin of IRQn or ExIRQn to input IRQ15 to IRQ2 interrupts can be selected.
$\overline{\text{KIN15}}$ to $\overline{\text{KIN0}}$	Input	Maskable external interrupts An interrupt is requested at falling edge.
$\overline{\text{WUE15}}$ to $\overline{\text{WUE8}}$	Input	Maskable external interrupts An interrupt is requested at falling edge.

5.3 Register Descriptions

The interrupt controller has the following registers. For details on the system control register (SYSCR), see section 3.2.2, System Control Register (SYSCR), and for details on the IRQ sense port select registers (ISSR16, ISSR), see section 8.16.1, IRQ Sense Port Select Register 16 (ISSR16), IRQ Sense Port Select Register (ISSR).

- Interrupt control registers A to D (ICRA to ICRD)
- Address break control register (ABRKCR)
- Break address registers A to C (BARA to BARC)
- IRQ sense control registers (ISCR16H, ISCR16L, ISCRH, ISCRL)
- IRQ enable registers (IER16, IER)
- IRQ status registers (ISR16, ISR)
- Keyboard matrix interrupt mask registers (KMIMRA, KMIMR6)
- Wake-up event interrupt mask register (WUEMR3)

5.3.1 Interrupt Control Registers A to D (ICRA to ICRD)

The ICR registers set interrupt control levels for interrupts other than NMI.

The correspondence between interrupt sources and ICRA to ICRD settings is shown in table 5.2.

Bit	Bit Name	Initial Value	R/W	Description
7 to 0	ICRn7 to IRCn0	All 0	R/W	Interrupt Control Level 0: Corresponding interrupt source is interrupt control level 0 (no priority) 1: Corresponding interrupt source is interrupt control level 1 (priority)

[Legend]

n: A to D

Table 5.2 Correspondence between Interrupt Source and ICR

Bit	Bit Name	Register			
		ICRA	ICRB	ICRC	ICRD
7	ICRn7	IRQ0	A/D converter	SCI_0	IRQ8 to IRQ11
6	ICRn6	IRQ1	FRT	SCI_1	IRQ12 to IRQ15
5	ICRn5	IRQ2, IRQ3	—	SCI_2	—
4	ICRn4	IRQ4, IRQ5	TMR_X	IIC_0	—
3	ICRn3	IRQ6, IRQ7	TMR_0	IIC_1	—
2	ICRn2	DTC	TMR_1	IIC_2, IIC_3	—
1	ICRn1	WDT_0	TMR_Y	LPC	—
0	ICRn0	WDT_1	IIC_4, IIC_5	—	—

[Legend]

n: A to D

—: Reserved. The write value should always be 0.

5.3.2 Address Break Control Register (ABRKCR)

ABRKCR controls the address breaks. When both the CMF flag and BIE flag are set to 1, an address break is requested.

Bit	Bit Name	Initial Value	R/W	Description
7	CMF	Undefined	R	Condition Match Flag Address break source flag. Indicates that an address specified by BARA to BARC is prefetched. [Clearing condition] When an exception handling is executed for an address break interrupt. [Setting condition] When an address specified by BARA to BARC is prefetched while the BIE flag is set to 1.
6 to 1	—	All 0	R	Reserved These bits are always read as 0 and cannot be modified.
0	BIE	0	R/W	Break Interrupt Enable Enables or disables address break. 0: Disabled 1: Enabled

5.3.3 Break Address Registers A to C (BARA to BARC)

The BAR registers specify an address that is to be a break address. An address in which the first byte of an instruction exists should be set as a break address. In normal mode, addresses A23 to A16 are not compared.

- BARA

Bit	Bit Name	Initial Value	R/W	Description
7 to 0	A23 to A16	All 0	R/W	Addresses 23 to 16 The A23 to A16 bits are compared with A23 to A16 in the internal address bus.

- BARB

Bit	Bit Name	Initial Value	R/W	Description
7 to 0	A15 to A8	All 0	R/W	Addresses 15 to 8 The A15 to A8 bits are compared with A15 to A8 in the internal address bus.

- BARC

Bit	Bit Name	Initial Value	R/W	Description
7 to 1	A7 to A1	All 0	R/W	Addresses 7 to 1 The A7 to A1 bits are compared with A7 to A1 in the internal address bus.
0	—	0	R	Reserved This bit is always read as 0 and cannot be modified.

5.3.4 IRQ Sense Control Registers (ISCR16H, ISCR16L, ISCRH, ISCR L)

The ISCR registers select the source that generates an interrupt request at pins $\overline{\text{IRQ}}_{15}$ to $\overline{\text{IRQ}}_0$ or pins $\overline{\text{ExIRQ}}_{15}$ to $\overline{\text{ExIRQ}}_2$.

• ISCR16H

Bit	Bit Name	Initial Value	R/W	Description
7	IRQ15SCB	0	R/W	IRQn Sense Control B
6	IRQ15SCA	0	R/W	IRQn Sense Control A
5	IRQ14SCB	0	R/W	00: Interrupt request generated at low level of $\overline{\text{IRQ}}_n$ or $\overline{\text{ExIRQ}}_n$ input
4	IRQ14SCA	0	R/W	
3	IRQ13SCB	0	R/W	01: Interrupt request generated at falling edge of $\overline{\text{IRQ}}_n$ or $\overline{\text{ExIRQ}}_n$ input
2	IRQ13SCA	0	R/W	
1	IRQ12SCB	0	R/W	10: Interrupt request generated at rising edge of $\overline{\text{IRQ}}_n$ or $\overline{\text{ExIRQ}}_n$ input
0	IRQ12SCA	0	R/W	
11: Interrupt request generated at both falling and rising edges of $\overline{\text{IRQ}}_n$ or $\overline{\text{ExIRQ}}_n$ input (n = 15 to 12)				

• ISCR16L

Bit	Bit Name	Initial Value	R/W	Description
7	IRQ11SCB	0	R/W	IRQn Sense Control B
6	IRQ11SCA	0	R/W	IRQn Sense Control A
5	IRQ10SCB	0	R/W	00: Interrupt request generated at low level of $\overline{\text{IRQ}}_n$ or $\overline{\text{ExIRQ}}_n$ input
4	IRQ10SCA	0	R/W	
3	IRQ9SCB	0	R/W	01: Interrupt request generated at falling edge of $\overline{\text{IRQ}}_n$ or $\overline{\text{ExIRQ}}_n$ input
2	IRQ9SCA	0	R/W	
1	IRQ8SCB	0	R/W	10: Interrupt request generated at rising edge of $\overline{\text{IRQ}}_n$ or $\overline{\text{ExIRQ}}_n$ input
0	IRQ8SCA	0	R/W	
11: Interrupt request generated at both falling and rising edges of $\overline{\text{IRQ}}_n$ or $\overline{\text{ExIRQ}}_n$ input (n = 11 to 8)				

- ISCRH

Bit	Bit Name	Initial Value	R/W	Description
7	IRQ7SCB	0	R/W	IRQn Sense Control B
6	IRQ7SCA	0	R/W	IRQn Sense Control A
5	IRQ6SCB	0	R/W	00: Interrupt request generated at low level of $\overline{\text{IRQn}}$ or $\overline{\text{ExIRQn}}$ input
4	IRQ6SCA	0	R/W	
3	IRQ5SCB	0	R/W	01: Interrupt request generated at falling edge of $\overline{\text{IRQn}}$ or $\overline{\text{ExIRQn}}$ input
2	IRQ5SCA	0	R/W	
1	IRQ4SCB	0	R/W	10: Interrupt request generated at rising edge of $\overline{\text{IRQn}}$ or $\overline{\text{ExIRQn}}$ input
0	IRQ4SCA	0	R/W	
				11: Interrupt request generated at both falling and rising edges of $\overline{\text{IRQn}}$ or $\overline{\text{ExIRQn}}$ input (n = 7 to 4)

- ISCRL

Bit	Bit Name	Initial Value	R/W	Description
7	IRQ3SCB	0	R/W	IRQn Sense Control B
6	IRQ3SCA	0	R/W	IRQn Sense Control A
5	IRQ2SCB	0	R/W	00: Interrupt request generated at low level of $\overline{\text{IRQn}}$ or $\overline{\text{ExIRQn}}^*$ input
4	IRQ2SCA	0	R/W	
3	IRQ1SCB	0	R/W	01: Interrupt request generated at falling edge of $\overline{\text{IRQn}}$ or $\overline{\text{ExIRQn}}^*$ input
2	IRQ1SCA	0	R/W	
1	IRQ0SCB	0	R/W	10: Interrupt request generated at rising edge of $\overline{\text{IRQn}}$ or $\overline{\text{ExIRQn}}^*$ input
0	IRQ0SCA	0	R/W	
				11: Interrupt request generated at both falling and rising edges of $\overline{\text{IRQn}}$ or $\overline{\text{ExIRQn}}^*$ input (n = 3 to 0)

Note: * $\overline{\text{ExIRQn}}$ stands for $\overline{\text{ExIRQ3}}$ or $\overline{\text{ExIRQ2}}$.

5.3.5 IRQ Enable Registers (IER16, IER)

The IER registers control the enabling and disabling of interrupt requests IRQ15 to IRQ0.

- IER16

Bit	Bit Name	Initial Value	R/W	Description
7 to 0	IRQ15E to IRQ8E	All 0	R/W	IRQn Enable (n = 15 to 8) The IRQn interrupt request is enabled when this bit is 1.

- IER

Bit	Bit Name	Initial Value	R/W	Description
7 to 0	IRQ7E to IRQ0E	All 0	R/W	IRQn Enable (n = 7 to 0) The IRQn interrupt request is enabled when this bit is 1.

5.3.6 IRQ Status Registers (ISR16, ISR)

The ISR registers are flag registers that indicate the status of IRQ15 to IRQ0 interrupt requests.

- ISR16

Bit	Bit Name	Initial Value	R/W	Description
7 to 0	IRQ15F to IRQ8F	All 0	R/W	<p>[Setting condition]</p> <ul style="list-style-type: none"> • When the interrupt source selected by the ISCR16 registers occurs <p>[Clearing conditions]</p> <ul style="list-style-type: none"> • When reading IRQnF flag when IRQnF = 1, then writing 0 to IRQnF flag • When interrupt exception handling is executed when low-level detection is set and $\overline{\text{IRQn}}$ or $\overline{\text{ExIRQn}}$ input is high • When IRQn interrupt exception handling is executed when falling-edge, rising-edge, or both-edge detection is set (n = 15 to 8)

- ISR

Bit	Bit Name	Initial Value	R/W	Description
7 to 0	IRQ7F to IRQ0F	All 0	R/W	<p>[Setting condition]</p> <ul style="list-style-type: none"> • When the interrupt source selected by the ISCR registers occurs <p>[Clearing conditions]</p> <ul style="list-style-type: none"> • When reading IRQnF flag when IRQnF = 1, then writing 0 to IRQnF flag • When interrupt exception handling is executed when low-level detection is set and $\overline{\text{IRQn}}$ or $\overline{\text{ExIRQn}}$* input is high • When IRQn interrupt exception handling is executed when falling-edge, rising-edge, or both-edge detection is set (n = 7 to 0)

Note: * $\overline{\text{ExIRQn}}$ stands for $\overline{\text{ExIRQ7}}$ to $\overline{\text{ExIRQ2}}$.

5.3.7 Keyboard Matrix Interrupt Mask Registers (KMIMRA, KMIMR6) Wake-Up Event Interrupt Mask Register (WUEMR3)

The KMIMR and WUEMR registers enable or disable key-sensing interrupt inputs ($\overline{\text{KIN15}}$ to $\overline{\text{KIN0}}$), and wake-up event interrupt inputs ($\overline{\text{WUE15}}$ to $\overline{\text{WUE8}}$). The KMIMRA, KMIMR6, and WUEMR3 registers can be accessed when the KINWUE bit in SYSCR is set to 1. See section 3.2.2, System Control Register (SYSCR).

- KMIMRA

Bit	Bit Name	Initial Value	R/W	Description
7 to 0	KMIM15 to KMIM8	All 1	R/W	<p>Keyboard Matrix Interrupt Mask</p> <p>These bits enable or disable a key-sensing input interrupt request (KIN15 to KIN8).</p> <p>0: Enables a key-sensing input interrupt request</p> <p>1: Disables a key-sensing input interrupt request</p>

- KMIMR6

Bit	Bit Name	Initial Value	R/W	Description
7 to 0	KMIM7 to KMIM0	All 1	R/W	<p>Keyboard Matrix Interrupt Mask</p> <p>These bits enable or disable a key-sensing input interrupt request (KIN7 to KIN0).</p> <p>0: Enables a key-sensing input interrupt request</p> <p>1: Disables a key-sensing input interrupt request</p>

- WUEMR3

Bit	Bit Name	Initial Value	R/W	Description
7 to 0	WUEM15 to WUEM8	All 1	R/W	<p>Wake-Up Event Interrupt Mask</p> <p>These bits enable or disable a wake-up event input interrupt request (WUE15 to WUE8).</p> <p>0: Enables a wake-up event input interrupt request</p> <p>1: Disables a wake-up event input interrupt request</p>

5.4 Interrupt Sources

5.4.1 External Interrupts

There are four external interrupts: NMI, IRQ15 to IRQ0, KIN15 to KIN0 and WUE15 to WUE8. These interrupts can be used to restore this LSI from software standby mode.

NMI Interrupt: NMI is the highest-priority interrupt, and is always accepted by the CPU regardless of the interrupt control mode or the status of the CPU interrupt mask bits. The NMIEG bit in SYSCR can be used to select whether an interrupt is requested at a rising edge or a falling edge on the NMI pin.

IRQ15 to IRQ0 Interrupts: Interrupts IRQ15 to IRQ0 are requested by an input signal at pins $\overline{\text{IRQ15}}$ to $\overline{\text{IRQ0}}$ or pins $\overline{\text{ExIRQ15}}$ to $\overline{\text{ExIRQ2}}$. Interrupts IRQ15 to IRQ0 have the following features:

- The interrupt exception handling for interrupt requests IRQ15 to IRQ0 can be started at an independent vector address.
- Using ISCR, it is possible to select whether an interrupt is generated by a low level, falling edge, rising edge, or both edges, at pins $\overline{\text{IRQ15}}$ to $\overline{\text{IRQ0}}$ or pins $\overline{\text{ExIRQ15}}$ to $\overline{\text{ExIRQ2}}$.
- Enabling or disabling of interrupt requests IRQ15 to IRQ0 can be selected with IER.
- The status of interrupt requests IRQ15 to IRQ0 is indicated in ISR. ISR flags can be cleared to 0 by software.

The detection of IRQ15 to IRQ0 interrupts does not depend on whether the relevant pin has been set for input or output. However, when a pin is used as an external interrupt input pin, clear the corresponding port DDR to 0 so that it is not used as an I/O pin for another function.

A block diagram of interrupts IRQ15 to IRQ0 is shown in figure 5.2.

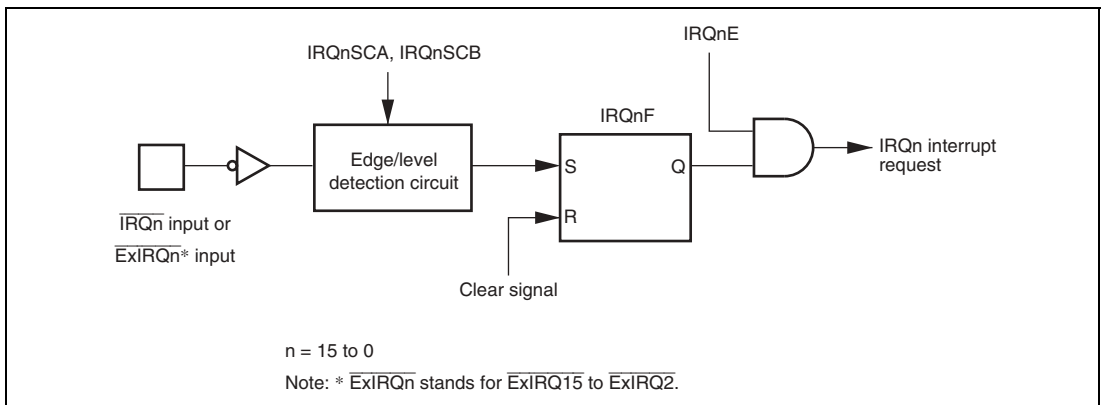

Figure 5.2 Block Diagram of Interrupts IRQ15 to IRQ0

KIN15 to KIN0 Interrupts, WUE15 to WUE8 Interrupts: Interrupts $\overline{\text{KIN15}}$ to $\overline{\text{KIN0}}$ and $\overline{\text{WUE15}}$ to $\overline{\text{WUE8}}$ are requested by an input signal at pins $\overline{\text{KIN15}}$ to $\overline{\text{KIN0}}$ and $\overline{\text{WUE15}}$ to $\overline{\text{WUE8}}$. Interrupts $\overline{\text{KIN15}}$ to $\overline{\text{KIN0}}$ and $\overline{\text{WUE15}}$ to $\overline{\text{WUE8}}$ have the following features:

- Interrupts $\overline{\text{KIN15}}$ and $\overline{\text{KIN8}}$, $\overline{\text{KIN7}}$ to $\overline{\text{KIN0}}$ and $\overline{\text{WUE15}}$ to $\overline{\text{WUE8}}$ each form a group. The interrupt exception handling for an interrupt request from the same group is started at the same vector address.
- Enabling or disabling of interrupt requests can be selected with the I bit in CCR.
- An interrupt is generated by a falling edge at pins $\overline{\text{KIN15}}$ to $\overline{\text{KIN0}}$ and $\overline{\text{WUE15}}$ to $\overline{\text{WUE8}}$.
- Enabling or disabling of interrupt requests $\overline{\text{KIN15}}$ to $\overline{\text{KIN0}}$ and $\overline{\text{WUE15}}$ to $\overline{\text{WUE8}}$ can be selected using KMIMRA, KMIMR6, and WUEMR3.
- The status of interrupt requests $\overline{\text{KIN15}}$ to $\overline{\text{KIN0}}$ and $\overline{\text{WUE15}}$ to $\overline{\text{WUE8}}$ are not indicated.

The detection of $\overline{\text{KIN15}}$ to $\overline{\text{KIN0}}$ and $\overline{\text{WUE15}}$ to $\overline{\text{WUE8}}$ interrupts does not depend on whether the relevant pin has been set for input or output. However, when a pin is used as an external interrupt input pin, clear the corresponding port DDR to 0 so that it is not used as an I/O pin for another function.

A block diagram of interrupts $\overline{\text{KIN15}}$ to $\overline{\text{KIN0}}$ and $\overline{\text{WUE15}}$ to $\overline{\text{WUE8}}$ is shown in figure 5.3.

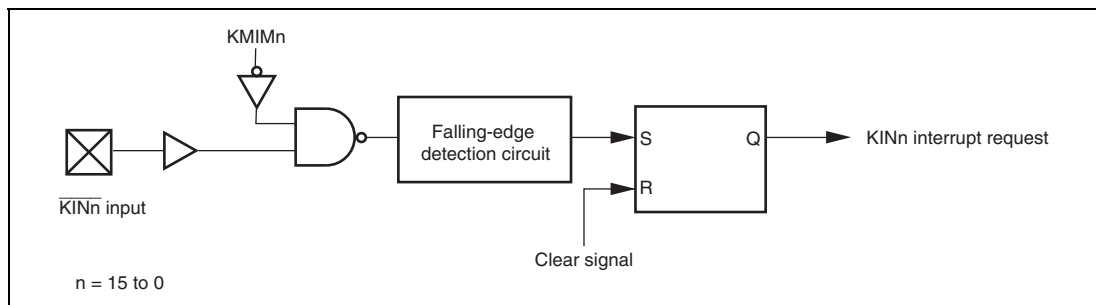

**Figure 5.3 Block Diagram of Interrupts $\overline{\text{KIN15}}$ to $\overline{\text{KIN0}}$ and $\overline{\text{WUE15}}$ to $\overline{\text{WUE8}}$
(Example of $\overline{\text{KIN15}}$ to $\overline{\text{KIN0}}$)**

5.4.2 Internal Interrupts

Internal interrupts issued from the on-chip peripheral modules have the following features:

- For each on-chip peripheral module there are flags that indicate the interrupt request status, and enable bits that individually select enabling or disabling of these interrupts. When the enable bit for a particular interrupt source is set to 1, an interrupt request is sent to the interrupt controller.
- The control level for each interrupt can be set by ICR.
- The DTC can be activated by an interrupt request from an on-chip peripheral module.
- An interrupt request that activates the DTC is not affected by the interrupt control mode or the status of the CPU interrupt mask bits.

5.5 Interrupt Exception Handling Vector Table

Table 5.3 lists interrupt exception handling sources, vector addresses, and interrupt priorities. For default priorities, the lower the vector number, the higher the priority. Modules set at the same priority will conform to their default priorities. Priorities within a module are fixed.

An interrupt control level can be specified for a module to which an ICR bit is assigned. Interrupt requests from modules that are set to interrupt control level 1 (priority) by the ICR bit setting are given priority and processed before interrupt requests from modules that are set to interrupt control level 0 (no priority).

Table 5.3 Interrupt Sources, Vector Addresses, and Interrupt Priorities

Origin of Interrupt Source	Name	Vector Number	Vector Address		Priority
			Advanced Mode	ICR	
External pin	NMI	7	H'00001C	—	High ↑ Low
	IRQ0	16	H'000040	ICRA7	
	IRQ1	17	H'000044	ICRA6	
	IRQ2	18	H'000048	ICRA5	
	IRQ3	19	H'00004C		
	IRQ4	20	H'000050	ICRA4	
	IRQ5	21	H'000054		
	IRQ6 IRQ7	22 23	H'000058 H'00005C	ICRA3	
DTC	SWDTEND (Software activation data transfer end)	24	H'000060	ICRA2	
WDT_0	WOVI0 (Interval timer)	25	H'000064	ICRA1	
WDT_1	WOVI1 (Interval timer)	26	H'000068	ICRA0	
—	Address break	27	H'00006C	—	
A/D converter	ADI (A/D conversion end)	28	H'000070	ICRB7	
EVC	EVENTI	29	H'000074	—	
External pin	KIN7 to KIN0	30	H'000078	—	
	KIN15 and KIN8	31	H'00007C		
	WUE15 to WUE8	33	H'000084		
TMR_X	CMIAx (Compare match A)	44	H'0000B0	ICRB4	
	CMIBx (Compare match B)	45	H'0000B4		
	OVIX (Overflow)	46	H'0000B8		
	ICIX (Input capture)	47	H'0000BC		

Table 5.3 Interrupt Sources, Vector Addresses, and Interrupt Priorities (cont)

Origin of Interrupt Source	Name	Vector Number	Vector Address		Priority
			Advanced Mode	ICR	
FRT	ICIA (Input capture A)	48	H'0000C0	ICRB6	High ↑
	ICIB (Input capture B)	49	H'0000C4		
	ICIC (Input capture C)	50	H'0000C8		
	ICID (Input capture D)	51	H'0000CC		
	OCIA (Output compare A)	52	H'0000D0		
	OCIB (Output compare B)	53	H'0000D4		
	FOVI (Overflow)	54	H'0000D8		
	External pin	IRQ8	56		
IRQ9		57	H'0000E4		
IRQ10		58	H'0000E8		
IRQ11		59	H'0000EC		
IRQ12		60	H'0000F0	ICRD6	
IRQ13		61	H'0000F4		
IRQ14		62	H'0000F8		
IRQ15		63	H'0000FC		
TMR_0	CMIA0 (Compare match A)	64	H'000100	ICRB3	
	CMIB0 (Compare match B)	65	H'000104		
	OV10 (Overflow)	66	H'000108		
TMR_1	CMIA1 (Compare match A)	68	H'000110	ICRB2	
	CMIB1 (Compare match B)	69	H'000114		
	OV11 (Overflow)	70	H'000118		
TMR_Y	CMIA_Y (Compare match A)	72	H'000120	ICRB1	
	CMIB_Y (Compare match B)	73	H'000124		
	OV1_Y (Overflow)	74	H'000128		
IIC_2	IIC12	76	H'000130	ICRC2	
IIC_3	IIC13	78	H'000138		
SCI_0	ERI0 (Reception error 0)	80	H'000140	ICRC7	
	RX10 (Reception completion 0)	81	H'000144		
	TX10 (Transmission data empty 0)	82	H'000148		
	TE10 (Transmission end 0)	83	H'00014C		
SCI_1	ERI1 (Reception error 1)	84	H'000150	ICRC6	
	RX11 (Reception completion 1)	85	H'000154		
	TX11 (Transmission data empty 1)	86	H'000158		
	TE11 (Transmission end 1)	87	H'00015C		
SCI_2	ERI2 (Reception error 2)	88	H'000160	ICRC5	
	RX12 (Reception completion 2)	89	H'000164		
	TX12 (Transmission data empty 2)	90	H'000168		
	TE12 (Transmission end 2)	91	H'00016C		

Table 5.3 Interrupt Sources, Vector Addresses, and Interrupt Priorities (cont)

Origin of Interrupt Source	Name	Vector Number	Vector Address		Priority
			Advanced Mode	ICR	
IIC_0	IIC10	94	H'000178	ICRC4	High ↑ Low
IIC_1	IIC11	98	H'000188	ICRC3	
IIC_4	IIC14	100	H'000190	ICRB0	
IIC_5	IIC15	102	H'000198		
LPC	ERR1 (transfer error, etc.)	104	H'0001A0	ICRC1	
	IBF11 (IDR1 reception completion)	105	H'0001A4		
	IBF12 (IDR2 reception completion)	106	H'0001A8		
	IBF13 (IDR3 reception completion)	107	H'0001AC		

5.6 Interrupt Control Modes and Interrupt Operation

The interrupt controller has two modes: Interrupt control mode 0 and interrupt control mode 1. Interrupt operations differ depending on the interrupt control mode. NMI interrupts and address break interrupts are always accepted except for in reset state or in hardware standby mode. The interrupt control mode is selected by SYSCR. Table 5.4 shows the interrupt control modes.

Table 5.4 Interrupt Control Modes

Interrupt Control Mode	SYSCR		Priority Setting Registers	Interrupt Mask Bits	Description
	INTM1	INTM0			
0	0	0	ICR	I	Interrupt mask control is performed by the I bit. Priority levels can be set with ICR.
1		1	ICR	I, UI	3-level interrupt mask control is performed by the I and UI bits. Priority levels can be set with ICR.

Figure 5.4 shows a block diagram of the priority decision circuit.

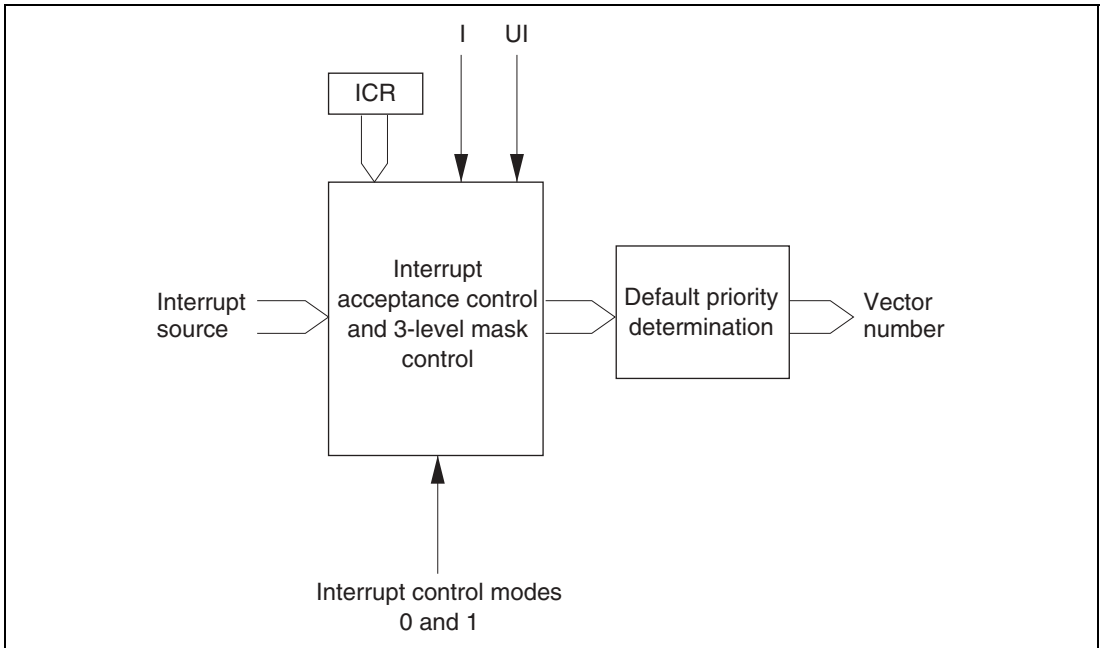

Figure 5.4 Block Diagram of Interrupt Control Operation

Interrupt Acceptance Control and 3-Level Control: In interrupt control modes 0 and 1, interrupt acceptance control and 3-level mask control is performed by means of the I and UI bits in CCR and ICR (control level).

Table 5.5 shows the interrupts selected in each interrupt control mode.

Table 5.5 Interrupts Selected in Each Interrupt Control Mode

Interrupt Control Mode	Interrupt Mask Bits		Selected Interrupts
	I	UI	
0	0	*	All interrupts (interrupt control level 1 has priority)
	1	*	NMI and address break interrupts
1	0	*	All interrupts (interrupt control level 1 has priority)
	1	0	NMI, address break, and interrupt control level 1 interrupts
		1	NMI and address break interrupts

[Legend]

*: Don't care

Default Priority Determination: The priority is determined for the selected interrupt, and a vector number is generated.

If the same value is set for ICR, acceptance of multiple interrupts is enabled, and so only the interrupt source with the highest priority according to the preset default priorities is selected and has a vector number generated.

Interrupt sources with a lower priority than the accepted interrupt source are held pending.

Table 5.6 shows operations and control signal functions in each interrupt control mode.

Table 5.6 Operations and Control Signal Functions in Each Interrupt Control Mode

Interrupt Control Mode	Setting		Interrupt Acceptance Control 3-Level Control			Default Priority Determination		T (Trace)
	INTM1	INTM0	I	UI	ICR			
0	0	0	○	IM	—	PR	○	—
1		1	○	IM	IM	PR	○	—

[Legend]

- O: Interrupt operation control performed
- IM: Used as an interrupt mask bit
- PR: Sets priority
- : Not used

5.6.1 Interrupt Control Mode 0

In interrupt control mode 0, interrupts other than NMI are masked by ICR and the I bit of the CCR in the CPU. Figure 5.5 shows a flowchart of the interrupt acceptance operation.

1. If an interrupt source occurs when the corresponding interrupt enable bit is set to 1, an interrupt request is sent to the interrupt controller.
2. According to the interrupt control level specified in ICR, the interrupt controller accepts an interrupt request with interrupt control level 1 (priority), and holds pending an interrupt request with interrupt control level 0 (no priority). If several interrupt requests are issued, an interrupt request with the highest priority is accepted according to the priority order, an interrupt handling is requested to the CPU, and other interrupt requests are held pending.
3. If the I bit in CCR is set to 1, only NMI and address break interrupt requests are accepted by the interrupt controller, and other interrupt requests are held pending. If the I bit is cleared to 0, any interrupt request is accepted. KIN, WUE, and EVENTI interrupts are enabled or disabled by the I bit.
4. When the CPU accepts an interrupt request, it starts interrupt exception handling after execution of the current instruction has been completed.
5. The PC and CCR are saved to the stack area by interrupt exception handling. The PC saved on the stack shows the address of the first instruction to be executed after returning from the interrupt handling routine.
6. Next, the I bit in CCR is set to 1. This masks all interrupts except for NMI and address break interrupts.
7. The CPU generates a vector address for the accepted interrupt and starts execution of the interrupt handling routine at the address indicated by the contents of the vector address in the vector table.

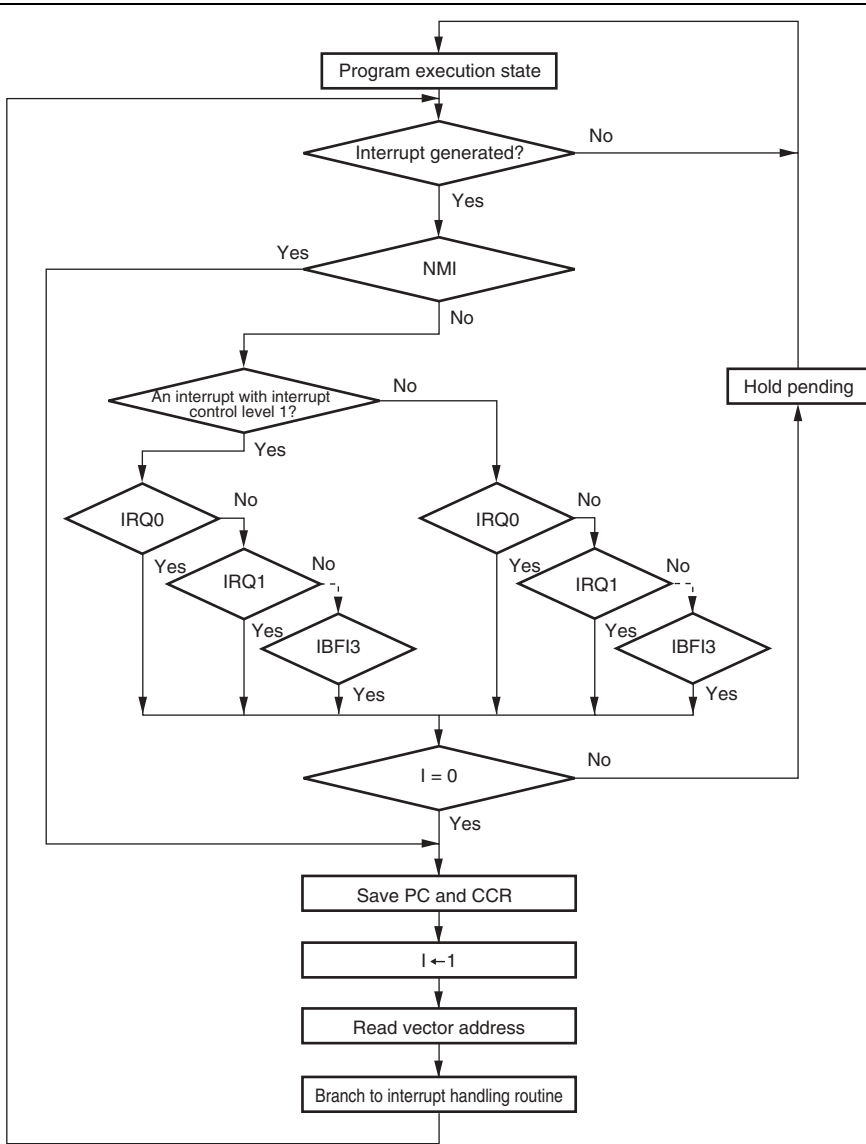

Figure 5.5 Flowchart of Procedure up to Interrupt Acceptance in Interrupt Control Mode 0

5.6.2 Interrupt Control Mode 1

In interrupt control mode 1, mask control is applied to three levels for IRQ and on-chip peripheral module interrupt requests by comparing the I and UI bits in CCR in the CPU, and the ICR setting.

1. An interrupt request with interrupt control level 0 is accepted when the I bit in CCR is cleared to 0. When the I bit is set to 1, the interrupt request is held pending.
EVENTI, KIN, and WUE interrupts are enabled or disabled by the I bit.
2. An interrupt request with interrupt control level 1 is accepted when the I bit or UI bit in CCR is cleared to 0. When both I and UI bits are set to 1, the interrupt request is held pending.

For instance, the state when the interrupt enable bit corresponding to each interrupt is set to 1, and ICRA to ICRD are set to H'20, H'00, H'00, and H'00, respectively (IRQ2 and IRQ3 interrupts are set to interrupt control level 1, and other interrupts are set to interrupt control level 0) is shown below. Figure 5.6 shows a state transition diagram.

1. All interrupt requests are accepted when $I = 0$. (Priority order: NMI > IRQ2 > IRQ3 > IRQ0 > IRQ1 > address break ...)
2. Only NMI, IRQ2, IRQ3, and address break interrupt requests are accepted when $I = 1$ and $UI = 0$.
3. Only NMI and address break interrupt requests are accepted when $I = 1$ and $UI = 1$.

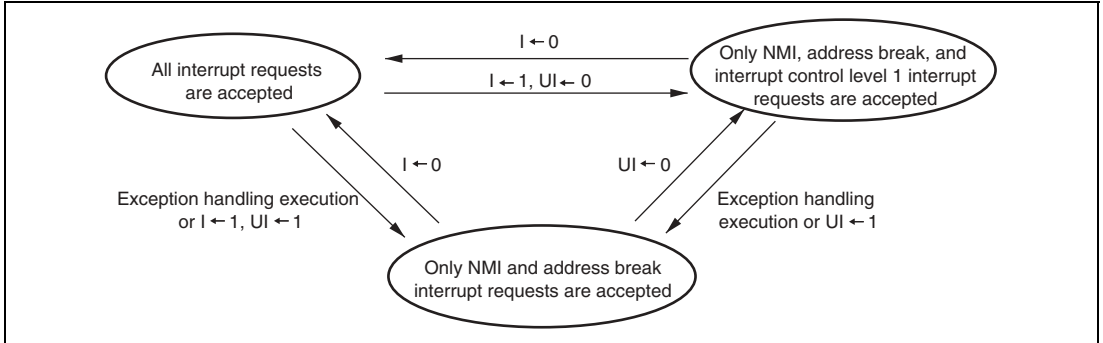

Figure 5.6 State Transition in Interrupt Control Mode 1

Figure 5.7 shows a flowchart of the interrupt acceptance operation.

1. If an interrupt source occurs when the corresponding interrupt enable bit is set to 1, an interrupt request is sent to the interrupt controller.
2. According to the interrupt control level specified in ICR, the interrupt controller only accepts an interrupt request with interrupt control level 1 (priority), and holds pending an interrupt request with interrupt control level 0 (no priority). If several interrupt requests are issued, an interrupt request with the highest priority is accepted according to the priority order, an interrupt handling is requested to the CPU, and other interrupt requests are held pending.
3. An interrupt request with interrupt control level 1 is accepted when the I bit is cleared to 0, or when the I bit is set to 1 while the UI bit is cleared to 0.
An interrupt request with interrupt control level 0 is accepted when the I bit is cleared to 0.
When both the I and UI bits are set to 1, only NMI and address break interrupt requests are accepted, and other interrupts are held pending.
When the I bit is cleared to 0, the UI bit is not affected.
4. When the CPU accepts an interrupt request, it starts interrupt exception handling after execution of the current instruction has been completed.
5. The PC and CCR are saved to the stack area by interrupt exception handling. The PC saved on the stack shows the address of the first instruction to be executed after returning from the interrupt handling routine.
6. The I and UI bits in CCR are set to 1. This masks all interrupts except for NMI and address break interrupts.
7. The CPU generates a vector address for the accepted interrupt and starts execution of the interrupt handling routine at the address indicated by the contents of the vector address in the vector table.

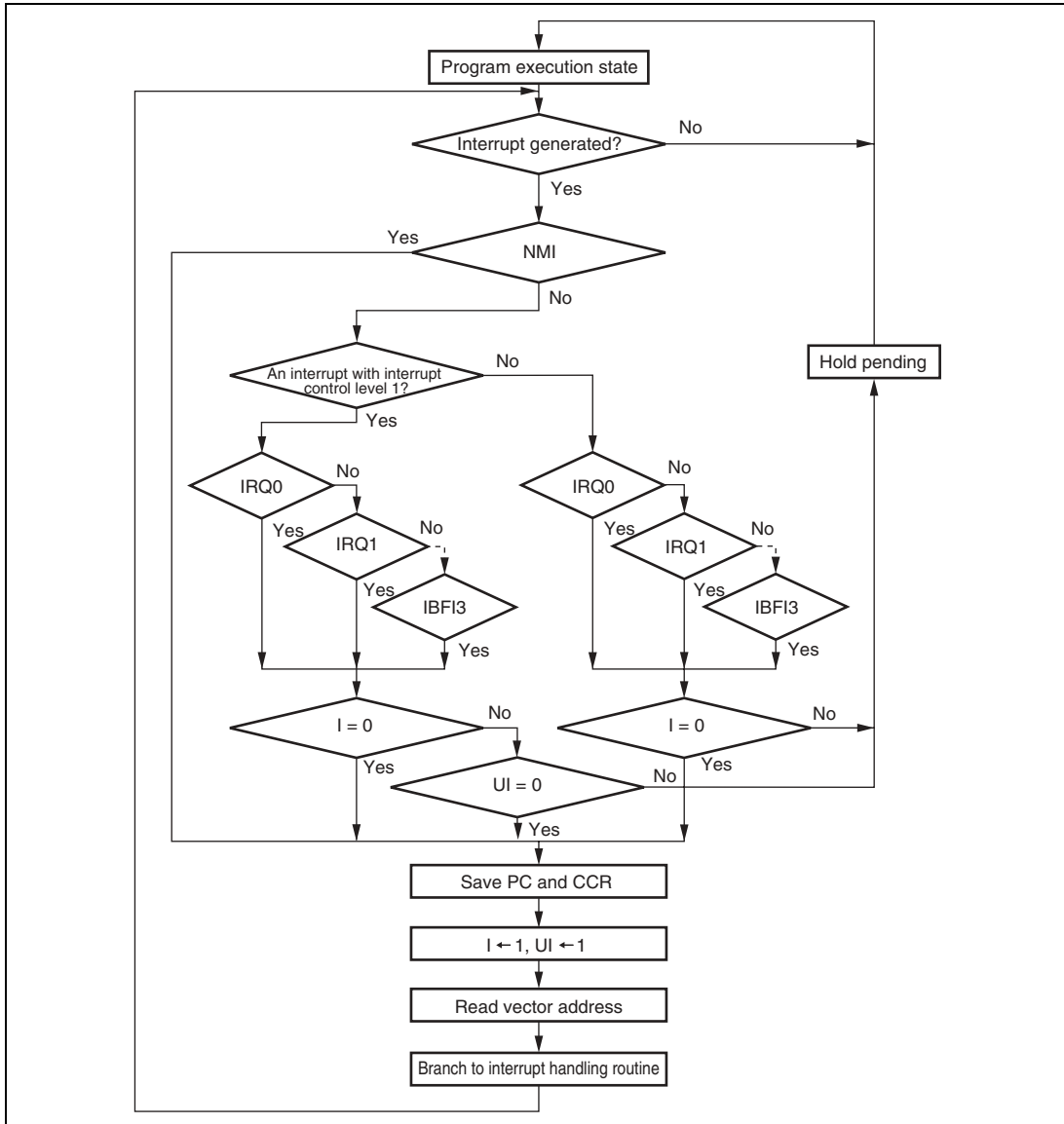

Figure 5.7 Flowchart of Procedure Up to Interrupt Acceptance in Interrupt Control Mode 1

5.6.3 Interrupt Exception Handling Sequence

Figure 5.8 shows the interrupt exception handling sequence. The example shown is for the case where interrupt control mode 0 is set in advanced mode, and the program area and stack area are in on-chip memory.

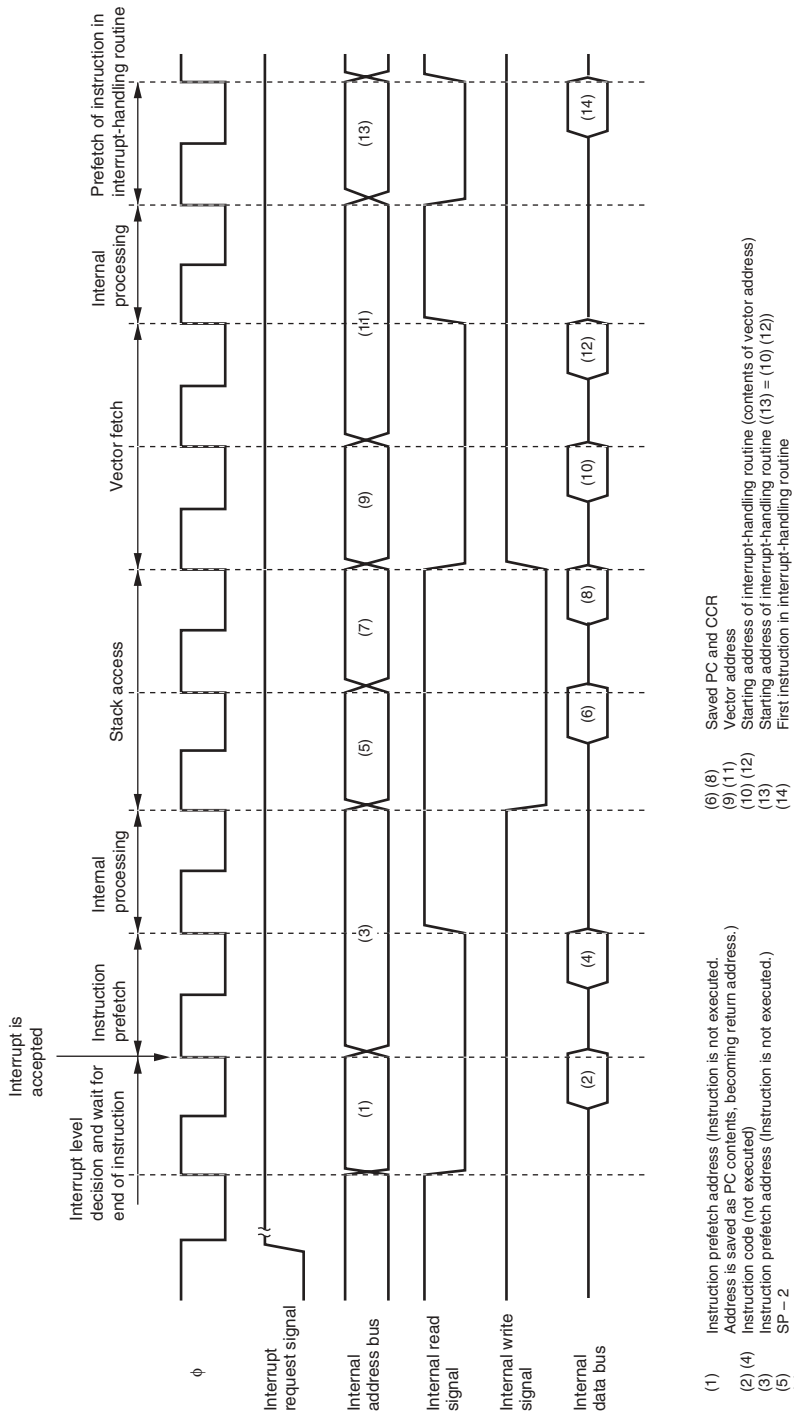

Figure 5.8 Interrupt Exception Handling

5.6.4 Interrupt Response Times

Table 5.7 shows interrupt response times – the intervals between generation of an interrupt request and execution of the first instruction in the interrupt handling routine. The execution status symbols used in table 5.7 are explained in table 5.8.

Table 5.7 Interrupt Response Times

No.	Execution Status	Advanced Mode
1	Interrupt priority determination* ¹	3
2	Number of wait states until executing instruction ends* ²	1 to (19 + 2·S _I)
3	PC, CCR stack save	2·S _K
4	Vector fetch	2·S _I
5	Instruction fetch* ³	2·S _I
6	Internal processing* ⁴	2
Total (using on-chip memory)		12 to 32

- Notes: 1. Two states in case of internal interrupt.
 2. Refers to MULXS and DIVXS instructions.
 3. Prefetch after interrupt acceptance and prefetch of interrupt handling routine.
 4. Internal processing after interrupt acceptance and internal processing after vector fetch.

Table 5.8 Number of States in Interrupt Handling Routine Execution Status

Symbol	Object of Access				
	Internal Memory	External Device		3-State Access	
		2-State Access	3-State Access		2-State Access
Instruction fetch S _I	1	4	6 + 2m	2	3 + m
Branch address read S _J					
Stack manipulation S _K					

[Legend]

m: Number of wait states in external device access.

5.6.5 DTC Activation by Interrupt

The DTC can be activated by an interrupt. In this case, the following options are available:

- Interrupt request to CPU
- Activation request to DTC
- Both of the above

For details of interrupt requests that can be used to activate the DTC, see section 7, Data Transfer Controller (DTC). Figure 5.9 shows a block diagram of the DTC and interrupt controller.

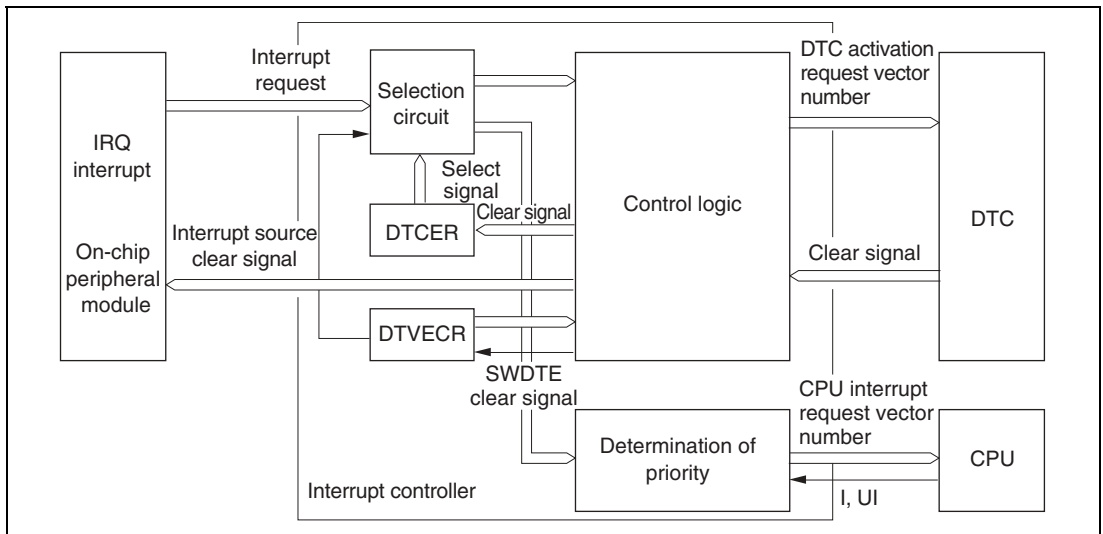

Figure 5.9 Interrupt Control for DTC

The interrupt controller has three main functions in DTC control.

Selection of Interrupt Source: It is possible to select DTC activation request or CPU interrupt request with the DTCE bit of DTCERA to DTCERE in the DTC. After a DTC data transfer, the DTCE bit can be cleared to 0 and an interrupt request sent to the CPU in accordance with the specification of the DIESEL bit of MRB in the DTC. When the DTC performs the specified number of data transfers and the transfer counter reaches 0, following the DTC data transfer the DTCE bit is cleared to 0 and an interrupt request is sent to the CPU.

Determination of Priority: The DTC activation source is selected in accordance with the default priority order, and is not affected by mask or priority levels. See section 7.5, Location of Register Information and DTC Vector Table, for the respective priorities.

Operation Order: If the same interrupt is selected as a DTC activation source and a CPU interrupt source, the DTC data transfer is performed first, followed by CPU interrupt exception handling.

Table 5.9 summarizes interrupt source selection and interrupt source clearing control according to the settings of the DTCE bit of DTCERA to DTCERE in the DTC and the DIESEL bit of MRB in the DTC.

Table 5.9 Interrupt Source Selection and Clearing Control

Settings		Interrupt Source Selection/Clearing Control	
DTC			
DTCE	DIESEL	DTC	CPU
0	*	×	Δ
1	0	Δ	×
	1	○	Δ

[Legend]

- Δ: The relevant interrupt is used. Interrupt source clearing is performed.
(The CPU should clear the source flag in the interrupt handling routine.)
- : The relevant interrupt is used. The interrupt source is not cleared.
- ×: The relevant interrupt cannot be used.
- *: Don't care

5.7 Usage Notes

5.7.1 Conflict between Interrupt Generation and Disabling

When an interrupt enable bit is cleared to 0 to disable interrupt requests, the disabling becomes effective after execution of the instruction. When an interrupt enable bit is cleared to 0 by an instruction such as BCLR or MOV, and if an interrupt is generated during execution of the instruction, the interrupt concerned will still be enabled on completion of the instruction, so interrupt exception handling for that interrupt will be executed on completion of the instruction. However, if there is an interrupt request of higher priority than that interrupt, interrupt exception handling will be executed for the higher-priority interrupt, and the lower-priority interrupt will be ignored. The same rule is also applied when an interrupt source flag is cleared to 0. Figure 5.10 shows an example in which the CMIEA bit in the TMR's TCR register is cleared to 0.

The above conflict will not occur if an enable bit or interrupt source flag is cleared to 0 while the interrupt is masked.

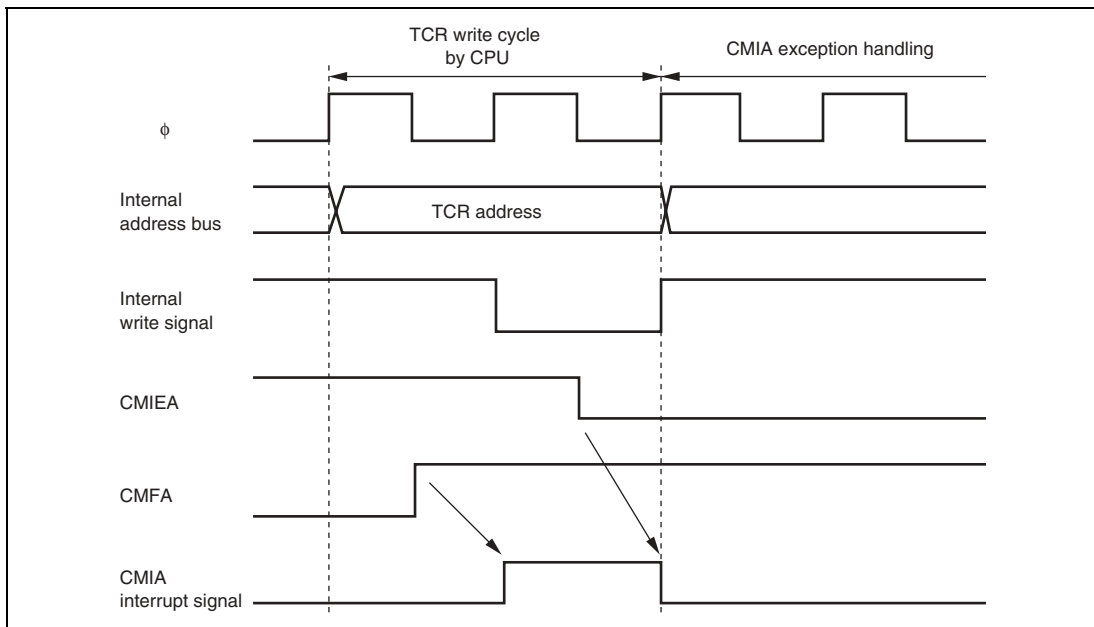

Figure 5.10 Conflict between Interrupt Generation and Disabling

5.7.2 Instructions that Disable Interrupts

The instructions that disable interrupts are LDC, ANDC, ORC, and XORC. After any of these instructions are executed, all interrupts including NMI are disabled and the next instruction is always executed. When the I bit or UI bit is set by one of these instructions, the new value becomes valid two states after execution of the instruction ends.

5.7.3 Interrupts during Execution of EEPMOV Instruction

Interrupt operation differs between the EEPMOV.B instruction and the EEPMOV.W instruction.

With the EEPMOV.B instruction, an interrupt request (including NMI) issued during the transfer is not accepted until the move is completed.

With the EEPMOV.W instruction, if an interrupt request is issued during the transfer, interrupt exception handling starts at a break in the transfer cycle. The PC value saved on the stack in this case is the address of the next instruction. Therefore, if an interrupt is generated during execution of an EEPMOV.W instruction, the following coding should be used.

```
L1:   EEPMOV.W
      MOV.W   R4, R4
      BNE    L1
```

5.7.4 IRQ Status Registers (ISR16, ISR)

Since IRQnF may be set to 1 according to the pin status after a reset, the ISR16 and the ISR should be read after a reset, and then write 0 in IRQnF (n = 15 to 0).

Section 6 Bus Controller (BSC)

This LSI has an on-chip bus controller (BSC) that manages the bus width and the number of access states of the external address space. The BSC also has a bus arbitration function, and controls the operation of the internal bus masters – CPU and data transfer controller (DTC).

6.1 Features

- Extended modes

Two modes for external extension

Normal extended mode: Normal extension (when the ADMXE bit in SYSCR2 is 0)

Address-data multiplex extended mode: Multiplex extension (when the ADMXE bit in SYSCR2 is 1)

- Extended area division

Possible in normal extended mode

The external address space can be accessed as basic extended areas.

A 256-kbyte extended area can be set and controlled independently of basic extended areas.

A CP extended area can be set and controlled independently of basic extended areas.

- Address pin reduction

In normal extended mode:

A 256-kbyte extended area from H'F80000 to H'FBFFFF can be selected using 18 address pins and the $\overline{\text{CS256}}$ signal.

A CP extended area (8 kbytes, basic mode) from H'FFC000 to H'FFDFFF can be selected using 13 address pins and the $\overline{\text{CPCS1}}$ signal.

A 2-kbyte area from H'FFF000 to H'FFF7FF can be selected using six to eleven address pins and the $\overline{\text{IOS}}$ signal.

In address-data multiplex extended mode:

The external address space can be accessed as the following three extended areas.

H'F80000 to H'F8FFFF	64 kbytes	256-kbyte extended area
H'FFC000 to H'FFDFFF	8 kbytes	CP extended area
H'FFF000 to H'FFF7FF	2 kbytes	IOS extended area

These areas can be selected using 8 pins or 16 pins, which is a total of address pins and data input/output pins.

- Control address hold signal and area select signal polarity

The output polarity of $\overline{\text{IOS}}$, $\overline{\text{CS256}}$, $\overline{\text{CPCS1}}$, and $\overline{\text{AH}}$ can be inverted by the PNCCS and PNCAH bits in LPWRCCR

- Multiplex bus interface

	No Wait Inserted		Wait Inserted	
	Address	Data	Address	Data
256-kbyte extended area	2 states *	2 states	2 states *	(3 + wait) states
CP extended area	2 states *	2 states	2 states *	(3 + wait) states
IOS extended area	2 states *	2 states	2 states *	(3 + wait) states

Note: * A wait cycle is inserted by the setting of the WC22 bit.

- Basic bus interface
 - 2-state access or 3-state access can be selected for each area.
 - Program wait states can be inserted for each area.
- Burst ROM interface
 - In normal extended mode
 - A burst ROM interface can be set for basic extended areas.
 - 1-state access or 2-state access can be selected for burst access.
- Idle cycle insertion
 - In normal extended mode
 - An idle cycle can be inserted for external write cycles immediately after external read cycles.
- Bus arbitration function
 - Includes a bus arbiter that arbitrates bus mastership between the CPU and DTC.

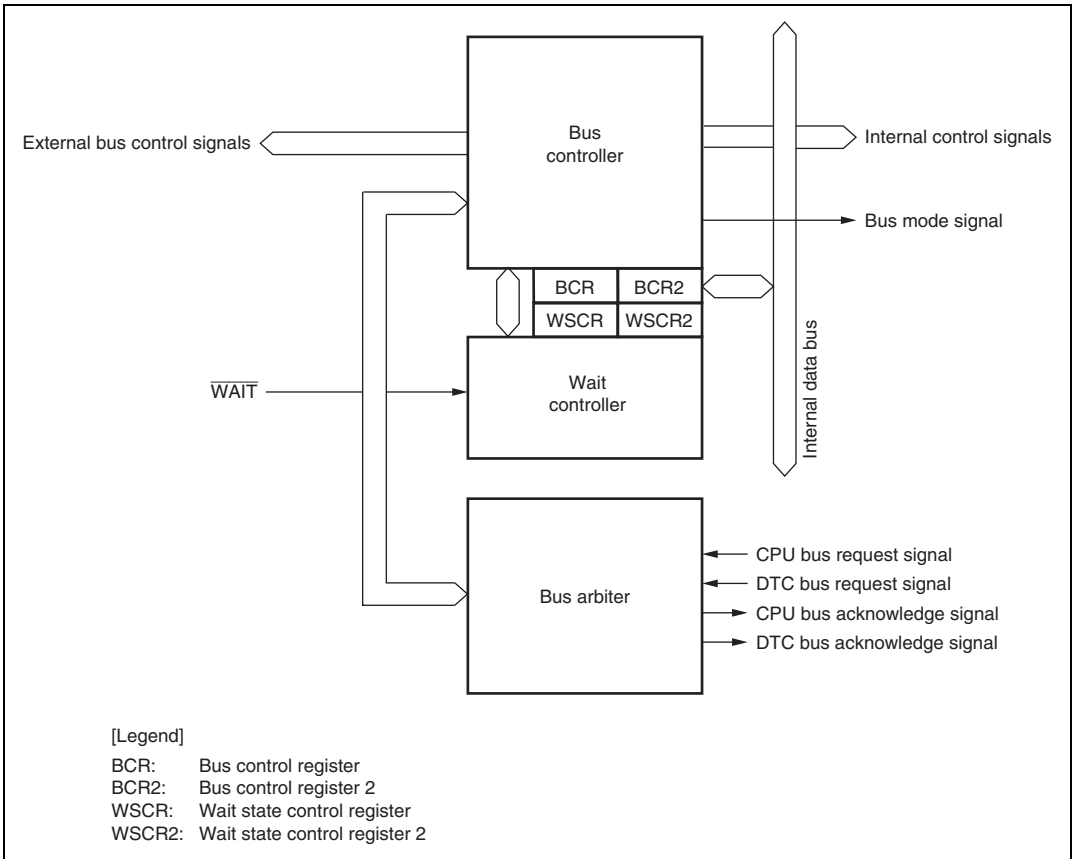

Figure 6.1 Block Diagram of Bus Controller

6.2 Input/Output Pins

Table 6.1 summarizes the pin configuration of the bus controller.

Table 6.1 Pin Configuration

Symbol	I/O	Function
\overline{AS}	Output	Strobe signal indicating that address output on the address bus is enabled (when the IOSE bit in SYSCR is cleared to 0). Note that this signal is not output when the 256-kbyte extended area is accessed (the CS256E bit in SYSCR is 1) or when the CP extended area is accessed (the CPCSE bit in BCR2 is 1).
\overline{IOS}	Output	Chip select signal indicating that the IOS extended area is being accessed (when the IOSE bit in SYSCR is 1).
$\overline{CPCS1}$	Output	Chip select signal indicating that the CP extended area is being accessed (when the CPCSE bit in BCR2 is 1).
$\overline{CS256}$	Output	Chip select signal indicating that the 256-kbyte extended area is being accessed (when the CS256E bit in SYSCR is 1).
\overline{RD}	Output	Strobe signal indicating that the external address space is being read.
\overline{HWR}	Output	Strobe signal indicating that the external address space is being written to, and the upper half (D15 to D8, AD15 to AD8) of the data bus is enabled.
\overline{LWR}	Output	Strobe signal indicating that the external address space is being written to, and the lower half (D7 to D0, AD7 to AD0) of the data bus is enabled.
\overline{WAIT}	Input	Wait request signal when accessing the external space.
\overline{AH}	Output	Signal indicating address fetch timing when the bus is in address-data multiplex bus state.
AD15 to AD0	Input/Output	Address output and data input/output pins for address-data multiplex extension.

6.3 Register Descriptions

The following registers are provided for the bus controller. For the system control register (SYSCR), see section 3.2.2, System Control Register (SYSCR). For system control register 2 (SYSCR2), see section 8.6.4, System Control Register 2 (SYSCR2).

- Bus control register (BCR)
- Bus control register 2 (BCR2)
- Wait state control register (WSCR)
- Wait state control register 2 (WSCR2)

6.3.1 Bus Control Register (BCR)

BCR is used to specify the access mode for the external address space and the I/O area range when the $\overline{AS}/\overline{IOS}$ pin is specified as an I/O strobe pin.

Bit	Bit Name	Initial Value	R/W	Description
7	—	1	R/W	Reserved The initial value should not be changed.
6	ICIS	1	R/W	Idle Cycle Insertion Selects whether or not to insert 1-state of the idle cycle between successive external read and external write cycles. 0: Idle cycle not inserted 1: 1-state idle cycle inserted
5	BRSTRM	0	R/W	Valid only in the normal extended mode. Burst ROM Enable Selects the bus interface for the external address space. 0: Basic bus interface 1: Burst ROM interface When the CS256E bit in SYSCR and the CPCSE bit in BCR2 are set to 1, burst ROM interface cannot be selected for the 256 -kbyte extended area and CP extended area.
4	BRSTS1	1	R/W	Valid only in the normal extended mode. Burst Cycle Select 1 Selects the number of states in the burst cycle of the burst ROM interface. 0: 1 state 1: 2 states

Bit	Bit Name	Initial Value	R/W	Description
3	BRSTS0	0	R/W	Valid only in the normal extended mode. Burst Cycle Select 0 Selects the number of words that can be accessed by burst access via the burst ROM interface. 0: Max, 4 words 1: Max, 8 words
2	—	0	R/W	Reserved The initial value should not be changed.
1	IOS1	1	R/W	IOS Select 1 and 0
0	IOS0	1	R/W	Select the address range where the $\overline{\text{IOS}}$ signal is output. See table 6.15.

6.3.2 Bus Control Register 2 (BCR2)

BCR2 is used to specify the access mode for the CP extended area.

Bit	Bit Name	Initial Value	R/W	Description
7, 6	—	All 0	R/W	Reserved The initial value should not be changed.
5	ABWCP	1	R/W	CP Extended Area Bus Width Control Selects the bus width for access to the CP extended area when the CPCSE bit is set to 1 0: 16-bit bus 1: 8-bit bus
4	ASTCP	1	R/W	CP Extended Area Access State Control Selects the number of states for access to the CP extended area when the CPCSE bit is set to 1. This bit also enables or disables wait-state insertion. [ADMXE = 0] Normal extension 0: 2-state access space. Wait state insertion disabled 1: 3-state access space. Wait state insertion enabled [ADMXE = 1] Address-data multiplex extension 0: 2-state data access space. Wait state insertion disabled 1: 3-state data access space. Wait state insertion enabled

Bit	Bit Name	Initial Value	R/W	Description
3	ADFULLE	0	R/W	<p>Address Output Full Enable</p> <p>Controls the address output in access to the IOS extended area, 256-kbyte extended area, or CP extended area. See section 8, I/O Ports. This is not supported while ADMXE = 1.</p>
2	EXCKS	0	R/W	<p>External Extension Clock Select</p> <p>Selects the operating clock used in external extended area access.</p> <p>0: Medium-speed clock is selected as the operating clock 1: System clock (ϕ) is selected as the operating clock.</p> <p>The operating clock is switched in the bus cycle prior to external extended area access.</p>
1	—	1	R/W	<p>Reserved</p> <p>The initial value should not be changed.</p>
0	CPCSE	0	R/W	<p>CP Extended Area Enable</p> <p>Selects the extended area to be accessed.</p> <p>0: External address space 1: CP extended area</p>

6.3.3 Wait State Control Register (WSCR)

WSCR is used to specify the data bus width, the number of access states, the wait mode, and the number of wait states for access to external address spaces (basic extended area and 256-kbyte extended area). The bus width and the number of access states for internal memory and internal I/O registers are fixed regardless of the WSCR settings.

Bit	Bit Name	Initial Value	R/W	Description
7	ABW256	1	R/W	<p>256-kbyte Extended Area Bus Width Control</p> <p>Selects the bus width for access to the 256-kbyte extended area when the CS256E bit in SYSCR is set to 1.</p> <p>0: 16-bit bus 1: 8-bit bus</p>
6	AST256	1	R/W	<p>256-kbyte Extended Area Access State Control</p> <p>Selects the number of states for access to the 256-kbyte extended area when the CS256E bit in SYSCR is set to 1. This bit also enables or disables wait-state insertion.</p> <p>[ADMXE = 0] Normal extension 0: 2-state access space. Wait state insertion disabled 1: 3-state access space. Wait state insertion enabled</p> <p>[ADMXE = 1] Address-data multiplex extension 0: 2-state data access space. Wait state insertion disabled 1: 3-state data access space. Wait state insertion enabled</p>
5	ABW	1	R/W	<p>Basic Extended Area Bus Width Control</p> <p>Selects the bus width for access to the basic extended area.</p> <p>0: 16-bit bus 1: 8-bit bus</p> <p>When the CS256E bit in SYSCR and the CPCSE bit in BCR2 are set to 1, this bit setting is ignored in 256-kbyte extended area access and CP extended area access.</p>

Bit	Bit Name	Initial Value	R/W	Description
4	AST	1	R/W	<p>Basic Extended Area Access State Control</p> <p>Selects the number of states for access to the basic extended area. This bit also enables or disables wait-state insertion.</p> <p>[ADMXE = 0] Normal extension</p> <p>0: 2-state access space. Wait state insertion disabled</p> <p>1: 3-state access space. Wait state insertion enabled</p> <p>[ADMXE = 1] Address-data multiplex extension</p> <p>0: 2-state data access space. Wait state insertion disabled</p> <p>1: 3-state data access space. Wait state insertion enabled</p> <p>When the CS256E bit in SYSCR and the CPCSE bit in BCR2 are set to 1, this bit setting is ignored in 256-kbyte extended area access and CP extended area access.</p>
3	WMS1	0	R/W	<p>Basic Extended Area Wait Mode Select 1 and 0</p> <p>Selects the wait mode for access to the basic extended area when the AST bit is set to 1.</p> <p>00: Program wait mode</p> <p>01: Wait disabled mode</p> <p>10: Pin wait mode</p> <p>11: Pin auto-wait mode</p> <p>When the CS256E bit in SYSCR and the CPCSE bit in BCR2 are set to 1, this bit setting is ignored in 256-kbyte extended area access and CP extended area access.</p>
2	WMS0	0	R/W	
1	WC1	1	R/W	<p>Basic Extended Area Wait Count 1 and 0</p> <p>Selects the number of program wait states to be inserted when the basic extended area is accessed when the AST bit is set to 1. The program wait state is only inserted into data cycles.</p> <p>00: Program wait state is not inserted</p> <p>01: 1 program wait state is inserted</p> <p>10: 2 program wait states are inserted</p> <p>11: 3 program wait states are inserted</p> <p>When the CS256E bit in SYSCR and the CPCSE bit in BCR2 are set to 1, this bit setting is ignored in 256-kbyte extended area access and CP extended area access.</p>
0	WC0	1	R/W	

6.3.4 Wait State Control Register 2 (WSCR2)

WSCR2 is used to specify the wait mode and number of wait states in access to the 256-kbyte extended area and CP extended area.

Bit	Bit Name	Initial Value	R/W	Description
7	WMS10	0	R/W	256-kbyte Extended Area Wait Mode Select 0 Selects the wait mode for access to the 256-kbyte extended area when the CS256E bit in SYSCR and the AST256 bit in WSCR are set to 1. 0: Program wait mode 1: Wait disabled mode
6	WC11	1	R/W	256-kbyte Extended Area Wait Count 1 and 0
5	WC10	1	R/W	Selects the number of program wait states to be inserted into the data cycle for access to the 256-kbyte extended area when the CS256E bit in SYSCR and the AST256 bit in WSCR are set to 1. 00: Program wait state is not inserted 01: 1 program wait state is inserted 10: 2 program wait states are inserted 11: 3 program wait states are inserted
4	WMS21	0	R/W	CP Extended Area Wait Mode Select 1 and 0
3	WMS20	0	R/W	Selects the wait mode for access to the CP extended area when the CPCSE and ASTCP bits in BCR2 are set to 1. 00: Program wait mode 01: Wait disabled mode 10: Pin wait mode 11: Pin auto-wait mode

- When ADMXE = 0

Bit	Bit Name	Initial Value	R/W	Description
2	WC22	1	R/W	CP Extended Area Wait Count 2 to 0
1	WC21	1	R/W	Select the number of program wait states to be inserted for access to the CP extended area when the CPCSE and ASTCP bits in BCR2 are set to 1. If the CP extended area is selected, the WC22 bit must be cleared to 0. 000: Program wait state is not inserted 001: 1 program wait state is inserted 010: 2 program wait states are inserted 011: 3 program wait states are inserted 100: (Setting prohibited) 101: (Setting prohibited) 110: (Setting prohibited) 111: (Setting prohibited)
0	WC20	1	R/W	

- When ADMXE = 1

Bit	Bit Name	Initial Value	R/W	Description
2	WC22	1	R/W	Address-Data Multiplex Extended Area Address Cycle Wait Count 2 Selects the number of program wait states to be inserted into the address cycle for access to the address-data multiplex extended area. 0: Program wait state is not inserted 1: 1 program wait state is inserted in the address cycle
1	WC21	1	R/W	CP Extended Area Data Cycle Wait Count 1 and 0 Selects the number of program wait states to be inserted in the data cycle for access to the CP extended area when the CPCSE and ASTCP bits in BCR2 are set to 1. 00: Program wait state is not inserted in the data cycle 01: 1 program wait state is inserted in the data cycle 10: 2 program wait states are inserted in the data cycle 11: 3 program wait states are inserted in the data cycle
0	WC20	1	R/W	

6.4 Bus Control

6.4.1 Bus Specifications

The external address space bus specifications consist of three elements: bus width, the number of access states, and the wait mode and the number of program wait states. The bus width and the number of access states for on-chip memory and internal I/O registers are fixed, and are not affected by the bus controller settings.

(1) In Normal Extended Mode

(a) Bus Width: A bus width of 8 or 16 bits can be selected via the ABW and ABW256 bits in WSCR, and the ABWCP bit in BCR2.

(b) Number of Access States: Two or three access states can be selected via the AST and AST256 bits in WSCR, and the ASTCP bit in BCR2. When the 2-state access space is designated, wait-state insertion is disabled.

In the burst ROM interface, the number of access states for the basic extended area is determined regardless of the AST bit setting.

(c) Wait Mode and Number of Program Wait States: When the basic extended area is specified as a 3-state access space by the AST bit in WSCR, the wait mode and the number of program wait states to be inserted automatically is selected by the WMS1, WMS0, WC1, and WC0 bits in WSCR. From 0 to 3 program wait states can be selected.

When the 256-kbyte extended area is specified as a 3-state access space by the AST256 bit in WSCR, the wait mode and the number of program wait states to be inserted automatically is selected by the WMS10, WC11, and WC10 bits in WSCR2. From 0 to 3 program wait states can be selected.

When the CP extended area is specified as a 3-state access space by the ASTCP bit in BCR2, the wait mode and the number of program wait states to be inserted automatically is selected by the WMS21, WMS20, WC21, and WC20 bits in WSCR2. From 0 to 3 program wait states can be selected.

The wait function for external extension is effective for connecting low-speed devices to the external address space. However, this wait function may cause some problems when the operation of bus masters other than the CPU, such as the DTC are to be delayed.

Tables 6.2 to 6.6 show each bit setting and external address space division in the address ranges of the external address space, and the bus specifications for the basic bus interface of each area.

Table 6.2 Address Ranges and External Address Spaces

Address Range	Areas	
	Basic Extended Area	256-kbyte Extended Area, CP Extended Area (Basic Mode)
H'080000 to H'F7FFFF (15 Mbytes)	○ No condition	—
H'F80000 to H'FBFFFF (256 kbytes) 256-kbyte extended area	△ When CS256E = 0, used as basic extended area.	When $\overline{\text{WAIT}}$ pin function is not selected while CS256E = 1, $\overline{\text{CS256}}$ is output and address pins A17 to A0 are used.
H'FC0000 to H'FEFFFF (192 kbytes)	○ No condition	—
H'FF0800 to H'FFBFFF (46 kbytes)	△ When RAME = 0, used as basic extended area.	—
H'FFC000 to H'FFDFFF (8 kbytes) CP extended area	△ When CPCSE = 0, used as basic extended area.	When CPCSE = 1, $\overline{\text{CPCS1}}$ is output in the CP extended area and address pins A12 to A0 are used.
H'FFE000 to H'FFE07F (128 bytes)	○ No condition	—
H'FFE080 to H'FFEFFF (3968 bytes)	△ When RAME = 0, used as basic extended area.	—
H'FFF000 to H'FFF7FF (2 kbytes)	○ No condition When IOSE = 1, $\overline{\text{IOS}}$ is output and address pins A10 to A0 are used.	—
H'FFFF00 to H'FFFF7F (128 bytes)	△ When RAME = 0, used as basic extended area.	—

[Legend]

- : This address range unconditionally accessed as the basic extended area.
- △: Condition for making this address range accessed as the basic extended area.
- : This address range cannot be used as a 256-kbyte extended area or CP extended area.

Table 6.3 Bit Settings and Bus Specifications of Basic Bus Interface

			Areas		
BRSTRM	CS256E	CPCSE	Basic Extended Area	256-kbyte Extended Area	CP Extended Area (Basic Mode)
0	0	0	Basic extended area	Used as basic extended area	Used as basic extended area
		1	ABW, AST, WMS1, WMS0, WC1, WC0		ABWCP, ASTCP, WMS21, WMS20, WC21, WC20
	1	0		ABW256, AST256, WMS10, WC11, WC10	Same as when CS256E = 0
		1			
1	0	0	Burst ROM interface*	Used as burst ROM interface	Used as burst ROM interface
		1	ABW, AST, WMS0, WC1, WC0, BRSTS1, BRSTS0		ABWCP, ASTCP, WMS21, WMS20, WC21, WC20
	1	0		ABW256, AST256, WMS10, WC11, WC10	Same as when CS256E = 0
		1			

Note: * In the burst ROM interface, the bus width is specified by the ABW bit in WSCR, the number of full access states (wait can be inserted) is specified by the AST bit in WSCR, and the number of access cycles in burst access is specified regardless of the AST bit setting.

Table 6.4 Bus Specifications for Basic Extended Area/Basic Bus Interface

						Bus Specifications		
ABW	AST	WMS1	WMS0	WC1	WC0	Bus Width	Number of Access States	Number of Program Wait States
0	0	*	*	*	*	16	2	0
	1	0	1	*	*	16	3	0
		Other than WMS1 = 0 and WMS0 = 1		0	0	1	3	0
				1	0			1
					1	0	1	2
					1	3		
1	0	*	*	*	*	8	2	0
	1	0	1	*	*	8	3	0
		Other than WMS1 = 0 and WMS0 = 1		0	0	1	3	0
				1	0			1
					1	0	1	2
					1	3		

[Legend]

*: Don't care

Table 6.5 Bus Specifications for 256-kbyte Extended Area/Basic Bus Interface

					Bus Specifications		
ABW256	AST256	WMS10	WC11	WC10	Bus Width	Number of Access States	Number of Program Wait States
0	0	*	*	*	16	2	0
	1	1	*	*	16	3	0
		0	0	0	0	3	0
				1			1
				1	0		2
			1		3		
1	0	*	*	*	8	2	0
	1	1	*	*	8	3	0
		0	0	0	0	3	0
				1			1
				1	0		2
			1		3		

[Legend]

*: Don't care

Table 6.6 Bus Specifications for CP Extended Area (Basic Mode)/Basic Bus Interface

						Bus Specifications		
ABWCP	ASTCP	WMS21	WMS20	WC21	WC20	Bus Width	Number of Access States	Number of Program Wait States
0	0	*	*	*	*	16	2	0
	1	0	1	*	*	16	3	0
		Other than WMS21 = 0 and WMS20 = 1		0	0		3	0
					1			1
				1	0			2
				1	3			
1	0	*	*	*	*	8	2	0
	1	0	1	*	*	8	3	0
		Other than WMS21 = 0 and WMS20 = 1		0	0		3	0
					1			1
				1	0			2
				1	3			

[Legend]

*: Don't care

(2) In Address-Data Multiplex Extended Mode

(a) **Bus Width:** A bus width of 8 or 16 bits can be selected via the ABW and ABW256 bits in WSCR, and the ABWCP bit in BCR2.

(b) **Number of Access States:** Two or three states can be selected for data access via the AST and AST256 bits in WSCR, and the ASTCP bit in BCR2. When the 2-state access space is designated, wait-state insertion is disabled.

(c) Wait Mode and Number of Program Wait States:

i) IOS Extended Area

When the IOS extended area is specified as a 3-state access space by the AST bit in WSCR, the wait mode and the number of program wait states to be inserted automatically is selected by the WMS1, WMS0, WC1, and WC0 bits in WSCR. Zero or one program wait state can be inserted into address cycle. From zero to three program wait states can be selected for data cycle.

ii) 256-kbyte Extended Area

When the 256-kbyte extended area is specified as a 3-state access space by the AST256 bit in WSCR, the wait mode and the number of program wait states to be inserted automatically is selected by the WMS10, WC11, and WC10 bits in WSCR2. Zero or one program wait state can be inserted into address cycle. From zero to three program wait states can be selected for data cycle.

iii) CP Extended Area

When the CP extended area is specified as a 3-state access space by the ASTCP bit in BCR2, the wait mode and the number of program wait states to be inserted automatically is selected by the WMS21, WMS20, WC22, WC21, and WC20 bits in WSCR2. Zero or one program wait state can be inserted into address cycle. From zero to three program wait states can be selected for data cycle.

The wait function for external extension is effective for connecting low-speed devices to the external address space. However, this wait function may cause some problems when the operation of bus masters other than the CPU, such as the DTC, are to be delayed.

Tables 6.7 to 6.14 show address-data multiplex address space and the bus specifications for the basic bus interface of each area.

Table 6.7 Address-Data Multiplex Address Spaces

Address Range	Address-Data Multiplex Area	
H'080000 to H'F7FFFF (15 Mbytes)	—	No condition
256-kbyte extended area H'F80000 to H'F8FFFF (64 kbytes)	O	When the $\overline{\text{WAIT}}$ pin function is not selected and CS256E = 1, CS256 is output and address AD15 to AD0 or AD7 to AD0 are used.
256-kbyte extended area H'F90000 to H'F9FFFF (64 kbytes)	—	No condition
256-kbyte extended area H'FA0000 to H'FAFFFF (64 kbytes)	—	No condition
256-kbyte extended area H'FB0000 to H'FBFFFF (64 kbytes)	—	No condition
H'FC0000 to H'FFBFFF (240 kbytes)	—	No condition
CP extended area H'FFC000 to H'FFDFFF (8 kbytes)	O	When CPCSE = 1, $\overline{\text{CPCS1}}$ is output, and address pins AD15 to AD0 or AD7 to AD0 are used.
H'FFE000 to H'FFEFFF (4 kbytes)	—	No condition
IOS extended area H'FFF000 to H'FFF7FF (2 kbytes)	O	When IOSE = 1, $\overline{\text{IOS}}$ is output and address pins AD15 to AD0 or AD7 to AD0 are used.
H'FFFF00 to H'FFFF7F (128 bytes)	—	No condition

[Legend]

- : This address range cannot be used as the address-data multiplex address space.
- O: Condition for making this address range accessed as the address-data multiplex address space.

Table 6.8 Bit Settings and Bus Specifications of Basic Bus Interface

			Area		
IOSE	CS256E	CPCSE	IOS Extended Area	256-kbyte Extended Area	CP Extended Area
1	0	0	ABW, AST, WMS1, WMS0, WC1, WC0	—	—
		1			ABWCP, ASTCP, WMS21, WMS20, WC21, WC20
	1	0			Same as when CS256E = 0
		1			ABW256, AST256, WMS10, WC11, WC10
0	0	0	—	—	—
		1			ABWCP, ASTCP, WMS21, WMS20, WC21, WC20
	1	0			Same as when CS256E = 0
		1			ABW256, AST256, WMS10, WC11, WC10

Table 6.9 Bus Specifications for IOS Extended Area/Multiplex Bus Interface (Address Cycle)

AST	WMS1	WMS0	WC22	WC1	WC0	Number of Access States	Number of Program Wait States
—	—	—	0	—	—	2	0
			1	—	—		1

Table 6.10 Bus Specifications for IOS Extended Area/Multiplex Bus Interface (Data Cycle)

AST	WMS1	WMS0	WC1	WC0	Number of Access States	Number of Program Wait States			
0	—	—	—	—	2	0			
1	0	1	—	—	3	0			
					Other than WMS1 = 0 and WMS0 = 1	0	0	3	0
							1		1
						1	0		2
		1		3					

Table 6.11 Bus Specifications for 256-kbyte Extended Area/Multiplex Bus Interface (Address Cycle)

AST256	WMS10	WC22	WC11	WC10	Number of Access States	Number of Program Wait States
—	—	0	—	—	2	0
		1	—	—		1

Table 6.12 Bus Specifications for 256-kbyte Extended Area/Multiplex Bus Interface (Data Cycle)

AST256	WMS1	WC1	WC0	Number of Access States	Number of Program Wait States
0	—	—	—	2	0
1	1	—	—	3	0
	0	0	0	3	0
			1		1
		1	0		2
			1		3

Table 6.13 Bus Specifications for CP Extended Area/Multiplex Bus Interface (Address Cycle)

ASTCP	WMS21	WMS20	WC22	WC21	WC20	Number of Access States	Number of Program Wait States
—	—	—	0	—	—	2	0
			1	—	—		1

Table 6.14 Bus Specifications for CP Extended Area/Multiplex Bus Interface (Data Cycle)

ASTCP	WMS21	WMS20	WC22	WC21	WC20	Number of Access States	Number of Program Wait States
0	—	—	—	—	—	2	0
1	0	1	—	—	—	3	0
	Other than WMS21 = 0 and WMS20 = 1		—	0	0	3	0
					1		1
				1	0		2
					1		3

6.4.2 Advanced Mode

The external address space (H'FFF000 to H'FFF7FF) can be accessed by specifying the $\overline{\text{AS}}/\overline{\text{IOS}}$ pin as an I/O strobe pin. The 256-kbyte extended area (H'F80000 to H'FBFFFF) and CP extended area (H'FFC000 to H'FFDFFF) can be accessed by the $\overline{\text{CS256}}$ pin and $\overline{\text{CPCS1}}$ pin functions, respectively.

The external address space is initialized as the basic bus interface and a 3-state access space. In mode 2, the address space other than on-chip ROM, on-chip RAM, internal I/O registers, and their reserved areas is specified as the external address space. The on-chip RAM and its reserved area are enabled when the RAME bit in SYSCR is set to 1, and disabled when the RAME bit is cleared to 0. Addresses H'FF0800 to H'FFBFFF, H'FFE080 to H'FFEFFF, and H'FFFF00 to H'FFFF7F in the on-chip RAM area and its reserved area are always specified as the external address space.

6.4.3 I/O Select Signals

The LSI can output I/O select signals ($\overline{\text{IOS}}$); the signal is driven low when the corresponding external address space is accessed. Figure 6.2 shows an example of $\overline{\text{IOS}}$ signal output timing.

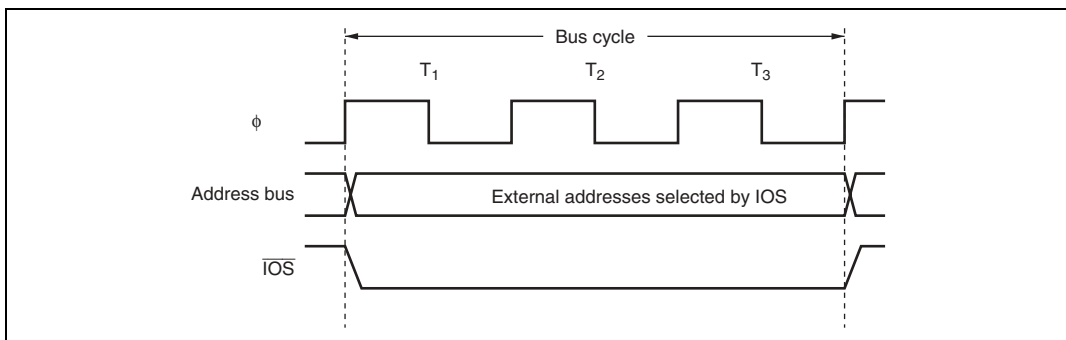

Figure 6.2 $\overline{\text{IOS}}$ Signal Output Timing

Enabling or disabling $\overline{\text{IOS}}$ signal output is performed by the IOSE bit in SYSCR. In the extended mode, the $\overline{\text{IOS}}$ pin functions as an $\overline{\text{AS}}$ pin by a reset. To use this pin as an $\overline{\text{IOS}}$ pin, set the IOSE bit to 1. For details, see section 8, I/O Ports.

The address ranges of the $\overline{\text{IOS}}$ signal output can be specified by the IOS1 and IOS0 bits in BCR, as shown in table 6.15.

Table 6.15 Address Range for $\overline{\text{IOS}}$ Signal Output

IOS1	IOS0	$\overline{\text{IOS}}$ Signal Output Range
0	0	H'FFF000 to H'FFF03F
	1	H'FFF000 to H'FFF0FF
1	0	H'FFF000 to H'FFF3FF
	1	H'FFF000 to H'FFF7FF (Initial value)

6.5 Bus Interface

The normal extended bus interface enables direct connection to ROM and SRAM. For details on selection of the bus specifications for the basic extended area, 256-kbyte extended area, and CP extended area, see tables 6.4 to 6.6.

The address-data multiplex extended bus interface enables direct connection to products that supports this bus interface. For details on selection of the bus specifications for the IOS extended area, 256-kbyte extended area, and CP extended area, see tables 6.9 to 6.14.

6.5.1 Data Size and Data Alignment

Data sizes for the CPU and other internal bus masters are byte, word, and longword. The BSC has a data alignment function, and controls whether the upper data bus (D15 to D8/AD15 to AD8) or lower data bus (D7 to D0/AD7 to AD0) is used when the external address space is accessed, according to the bus specifications for the area being accessed (8-bit access space or 16-bit access space) and the data size.

(1) 8-Bit Access Space: Figure 6.3 illustrates data alignment control for the 8-bit access space. With the 8-bit access space, the upper data bus (D15 to D8/AD15 to AD8) is always used for accesses. The amount of data that can be accessed at one time is one byte: a word access is performed as two byte accesses, and a longword access, as four byte accesses.

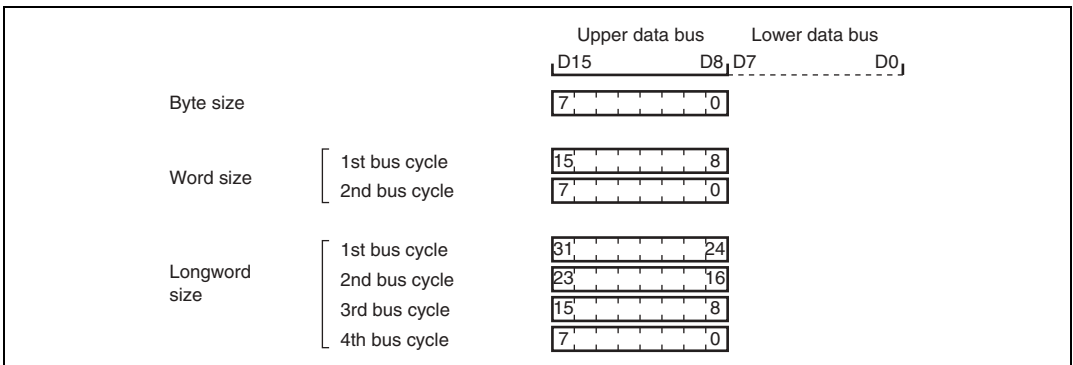

Figure 6.3 Access Sizes and Data Alignment Control (8-bit Access Space)

(2) 16-Bit Access Space: Figure 6.4 illustrates data alignment control for the 16-bit access space. With the 16-bit access space, the upper data bus (D15 to D8/AD15 to AD8) and lower data bus (D7 to D0/AD7 to AD0) are used for accesses. The amount of data that can be accessed at one time is one byte or one word, and a longword access is executed as two word accesses.

In byte access, whether the upper or lower data bus is used is determined by whether the address is even or odd. The upper data bus is used for even addresses, and the lower data bus for odd addresses.

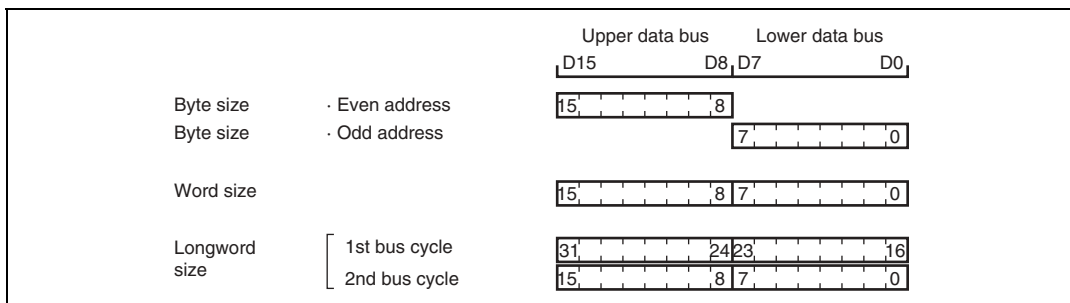

Figure 6.4 Access Sizes and Data Alignment Control (16-bit Access Space)

6.5.2 Valid Strobes

Table 6.16 shows the data buses used and valid strobes for each access space.

In a read, the \overline{RD} signal is valid for both the upper and lower halves of the data bus. In a write, the \overline{HWR} signal is valid for the upper half of the data bus, and the \overline{LWR} signal for the lower half.

Table 6.16 Data Buses Used and Valid Strobes

Area	Access Size	Read/Write	Address	Valid Strobe	Upper Data Bus (D15 to D8/AD15 to AD8)	Lower Data Bus (D7 to D0/AD7 to AD0)
8-bit access space	Byte	Read	—	\overline{RD}	Valid	Ports or others
		Write	—	\overline{HWR}		Ports or others
16-bit access space	Byte	Read	Even	\overline{RD}	Valid	Invalid
			Odd		Invalid	Valid
		Write	Even	\overline{HWR}	Valid	Undefined
			Odd	\overline{LWR}	Undefined	Valid
	Word	Read	—	\overline{RD}	Valid	Valid
		Write	—	$\overline{HWR}, \overline{LWR}$	Valid	Valid

[Legend]

Undefined: Undefined data is output.

Invalid: Input state with the input value ignored.

Ports or others: Used as ports or I/O pins for on-chip peripheral modules, and are not used as the data bus.

6.5.3 Basic Operation Timing in Normal Extended Mode

(1) 8-Bit, 2-State Access Space: Figure 6.5 shows the bus timing for an 8-bit, 2-state access space. When an 8-bit access space is accessed, the upper half (D15 to D8) of the data bus is used. Wait states cannot be inserted.

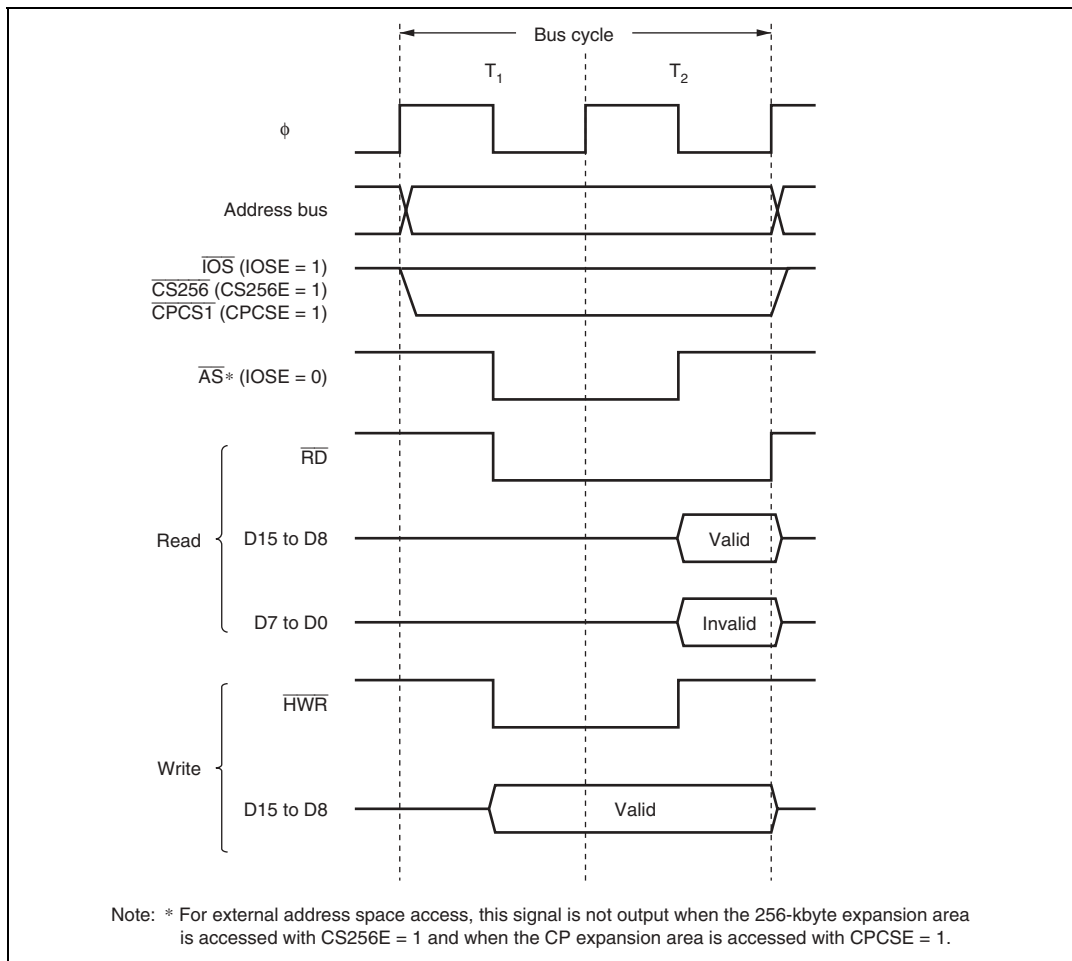

Figure 6.5 Bus Timing for 8-Bit, 2-State Access Space

(2) 8-Bit, 3-State Access Space: Figure 6.6 shows the bus timing for an 8-bit, 3-state access space. When an 8-bit access space is accessed, the upper half (D15 to D8) of the data bus is used. Wait states can be inserted.

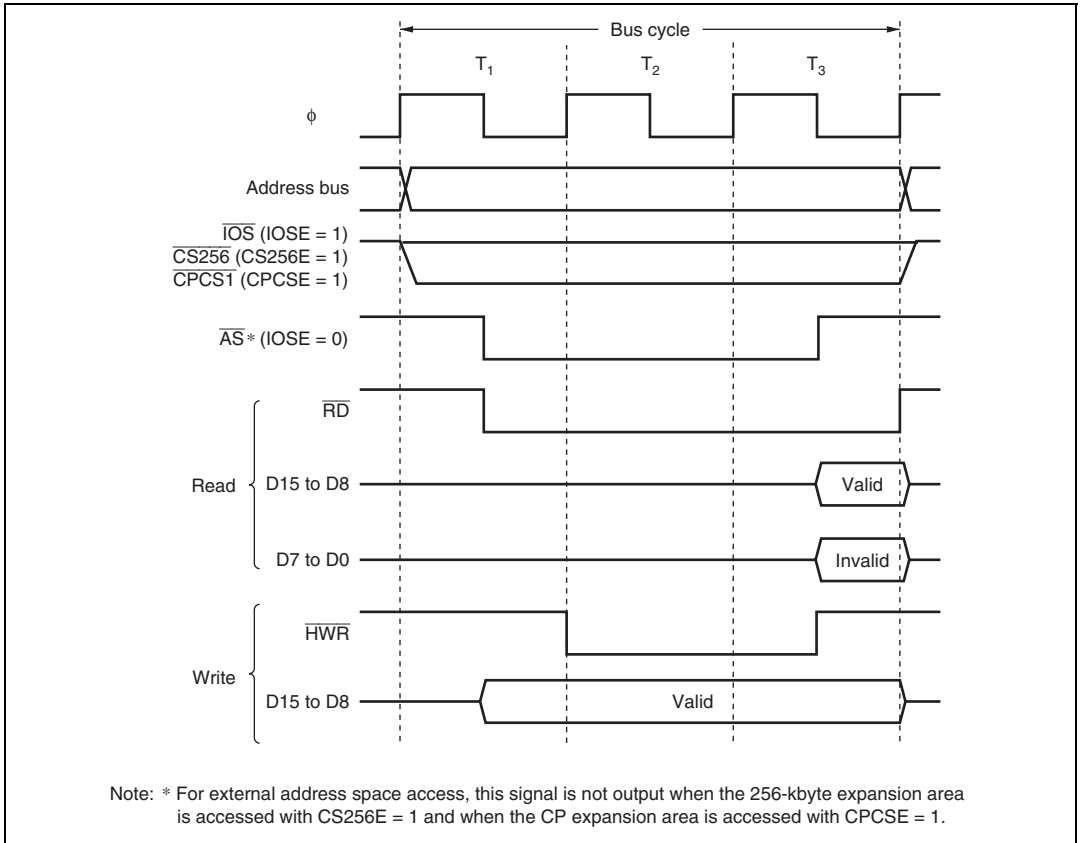

Figure 6.6 Bus Timing for 8-Bit, 3-State Access Space

(3) 16-Bit, 2-State Access Space: Figures 6.7 to 6.9 show bus timings for a 16-bit, 2-state access space. When a 16-bit access space is accessed, the upper half (D15 to D8) of the data bus is used for even addresses, and the lower half (D7 to D0) for odd addresses. Wait states cannot be inserted.

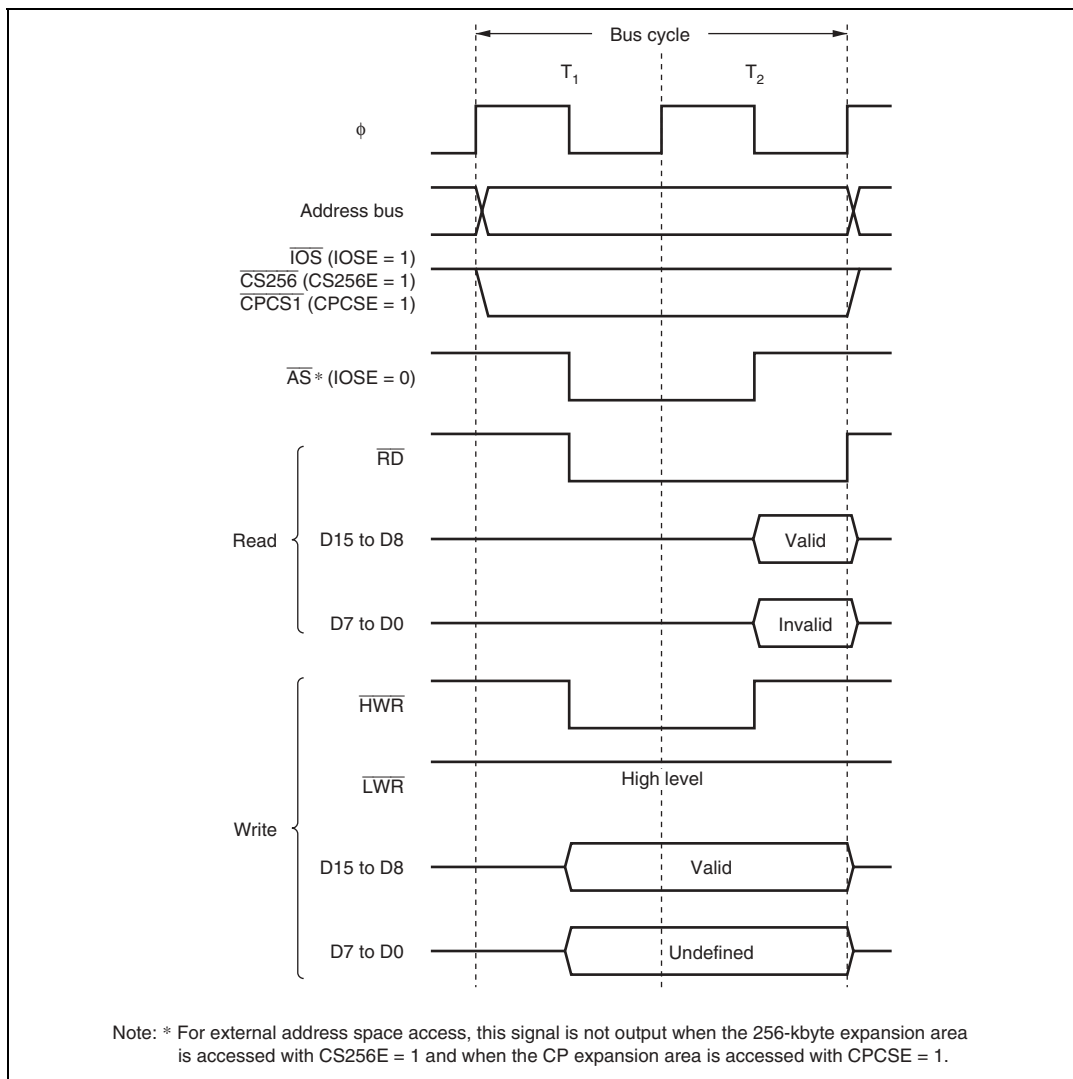
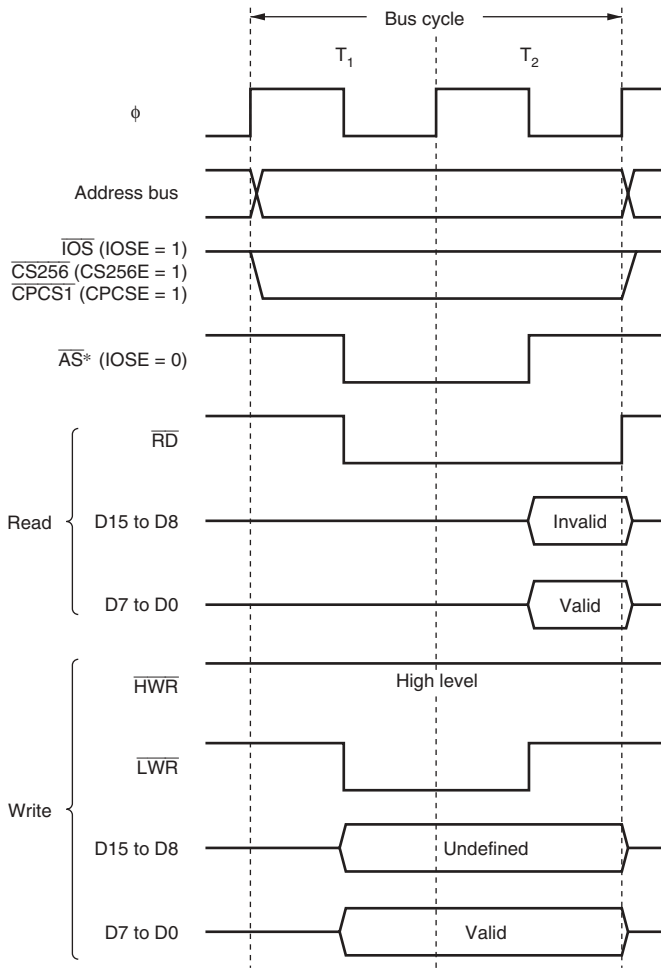
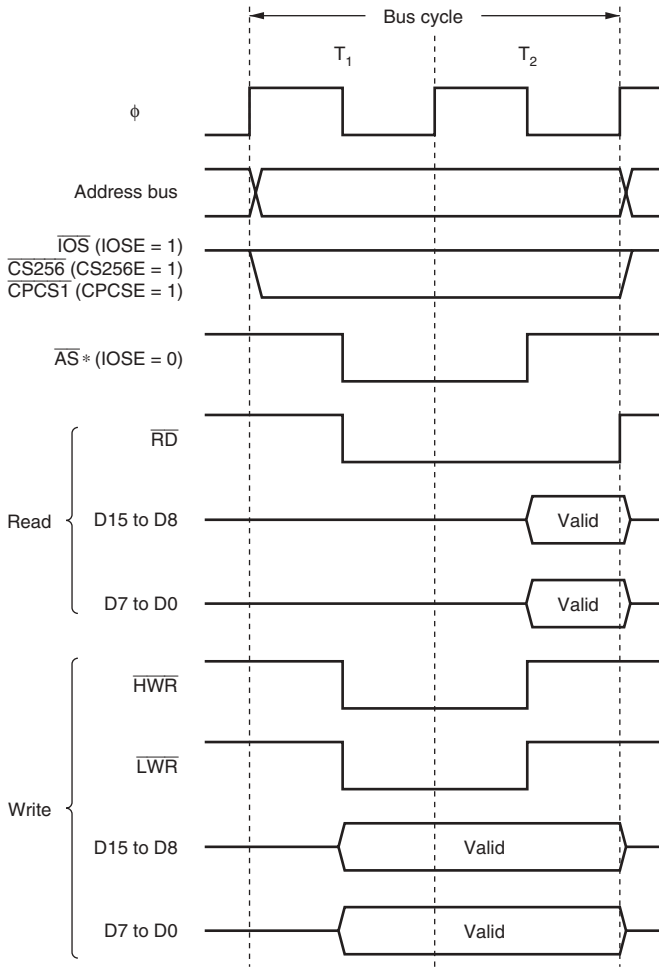

Figure 6.7 Bus Timing for 16-Bit, 2-State Access Space (Even Byte Access)



Note: * For external address space access, this signal is not output when the 256-kbyte expansion area is accessed with CS256E = 1 and when the CP expansion area is accessed with CPCSE = 1.

Figure 6.8 Bus Timing for 16-Bit, 2-State Access Space (Odd Byte Access)



Note: * For external address space access, this signal is not output when the 256-kbyte expansion area is accessed with CS256E = 1 and when the CP expansion area is accessed with CPCSE = 1.

Figure 6.9 Bus Timing for 16-Bit, 2-State Access Space (Word Access)

(4) 16-Bit, 3-State Access Space: Figures 6.10 to 6.12 show bus timings for a 16-bit, 3-state access space. When a 16-bit access space is accessed, the upper half (D15 to D8) of the data bus is used for even addresses, and the lower half (D7 to D0) for odd addresses. Wait states can be inserted.

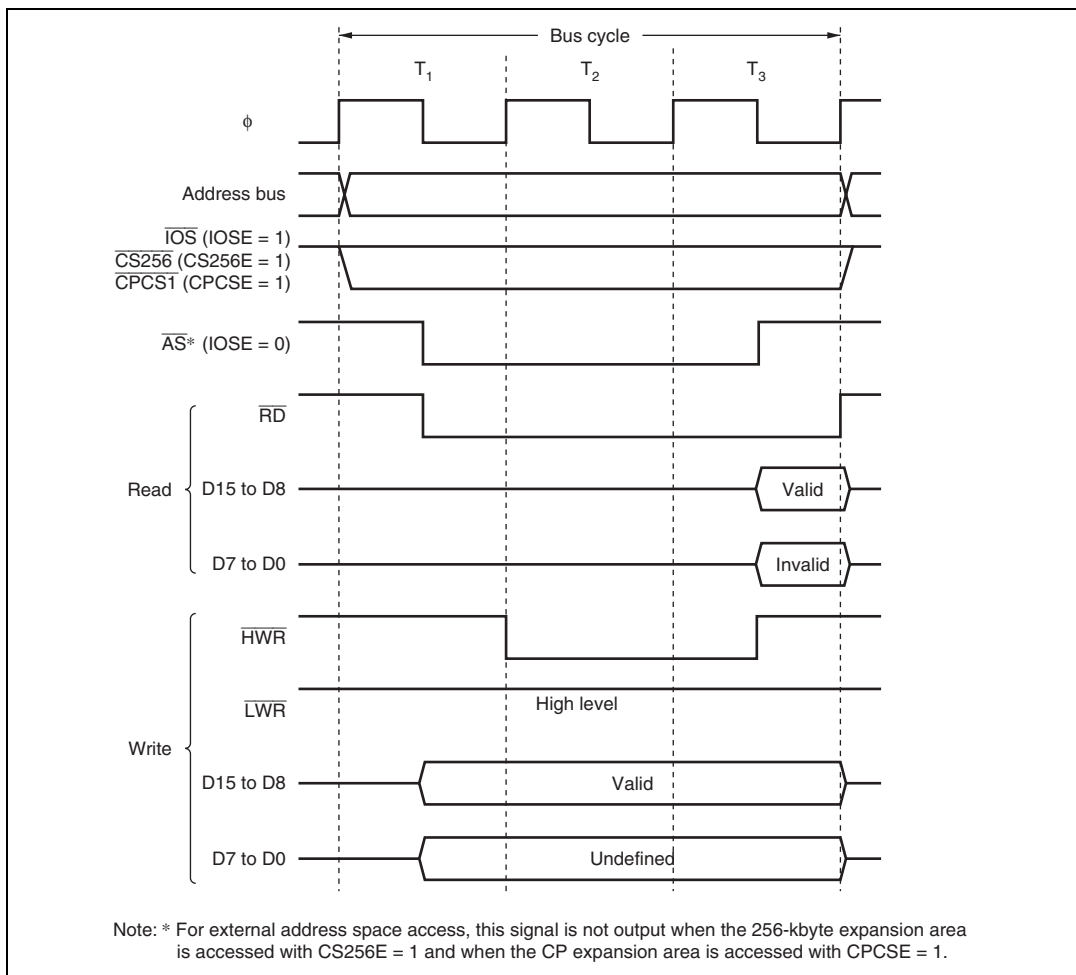
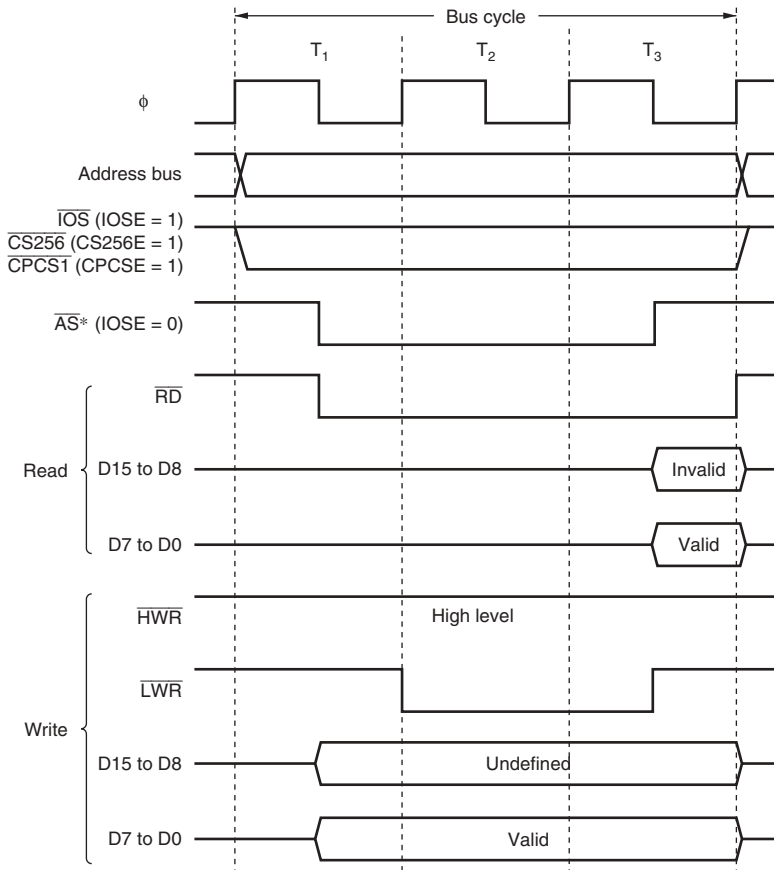
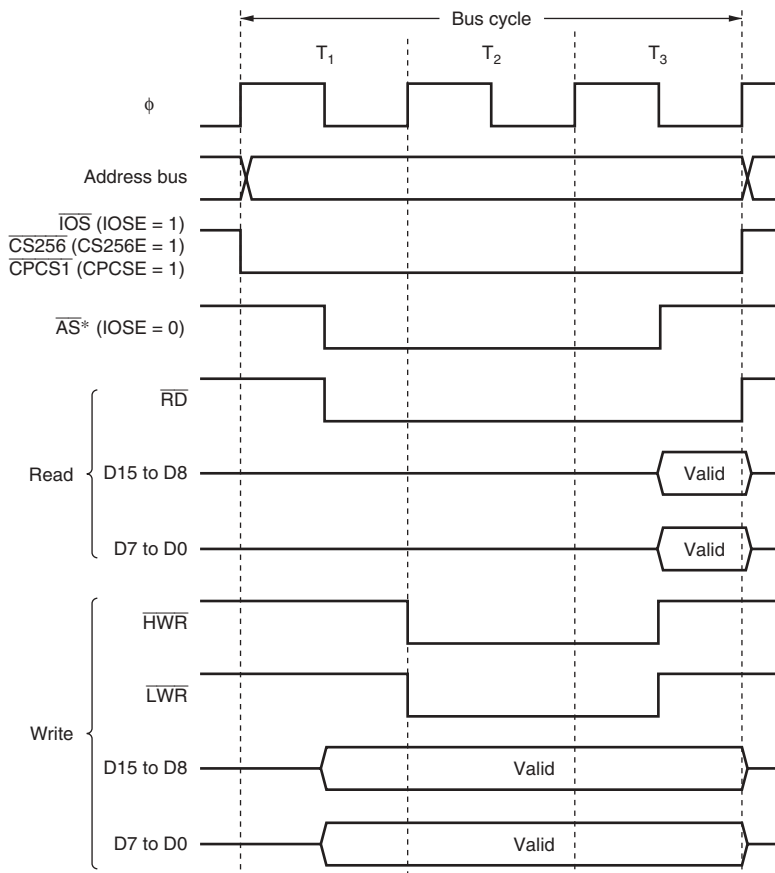

Figure 6.10 Bus Timing for 16-Bit, 3-State Access Space (Even Byte Access)



Note: * For external address space access, this signal is not output when the 256-kbyte expansion area is accessed with CS256E = 1 and when the CP expansion area is accessed with CPCSE = 1.

Figure 6.11 Bus Timing for 16-Bit, 3-State Access Space (Odd Byte Access)



Note: * For external address space access, this signal is not output when the 256-kbyte expansion area is accessed with CS256E = 1 and when the CP expansion area is accessed with CPCSE = 1.

Figure 6.12 Bus Timing for 16-Bit, 3-State Access Space (Word Access)

6.5.4 Basic Operation Timing in Address-Data Multiplexed Mode

(1) **8-Bit, 2-State Data Access Space:** Figures 6.13 and 6.14 show the bus timing for an 8-bit, 2-state access space. When an 8-bit access space is accessed, the upper half (AD15 to AD8) of the data bus is used. Wait states cannot be inserted.

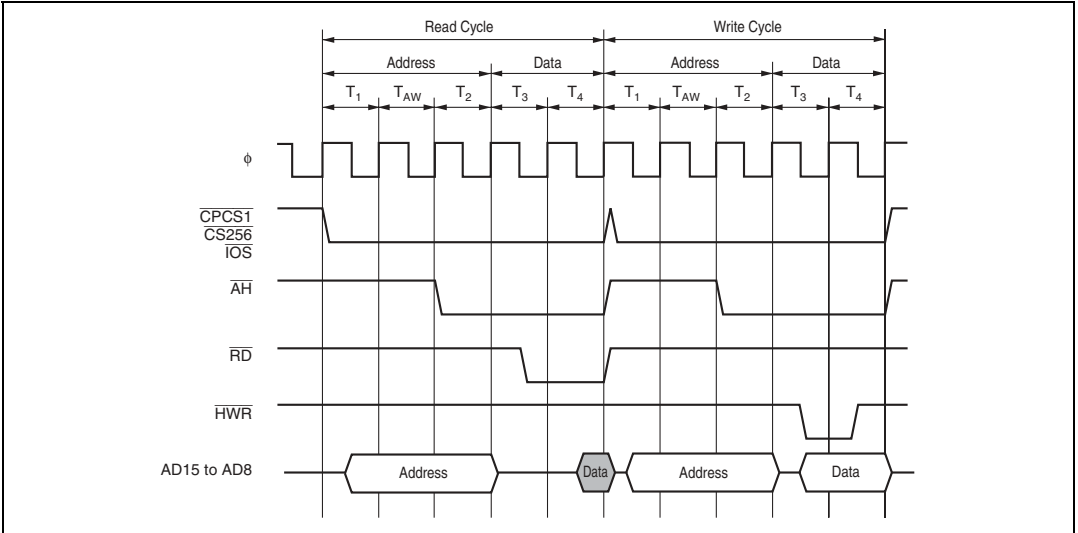

Figure 6.13 Bus Timing for 8-Bit, 2-State Access Space

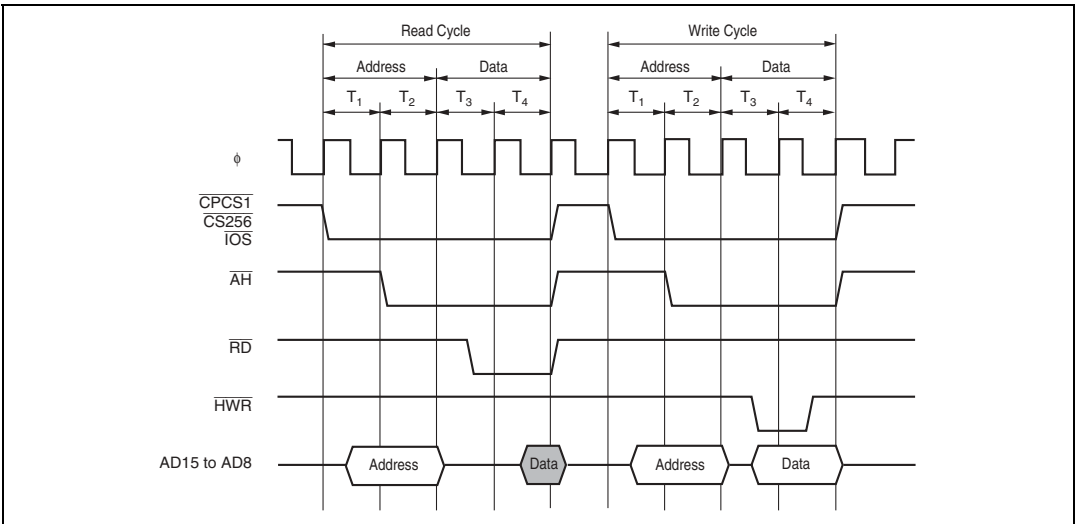

Figure 6.14 Bus Timing for 8-Bit, 2-State Access Space

(2) 8-Bit, 3-State Data Access Space: Figure 6.15 shows the bus timing for an 8-bit, 3-state access space. When an 8-bit access space is accessed, the upper half (AD15 to AD8) of the data bus is used. Wait states can be inserted.

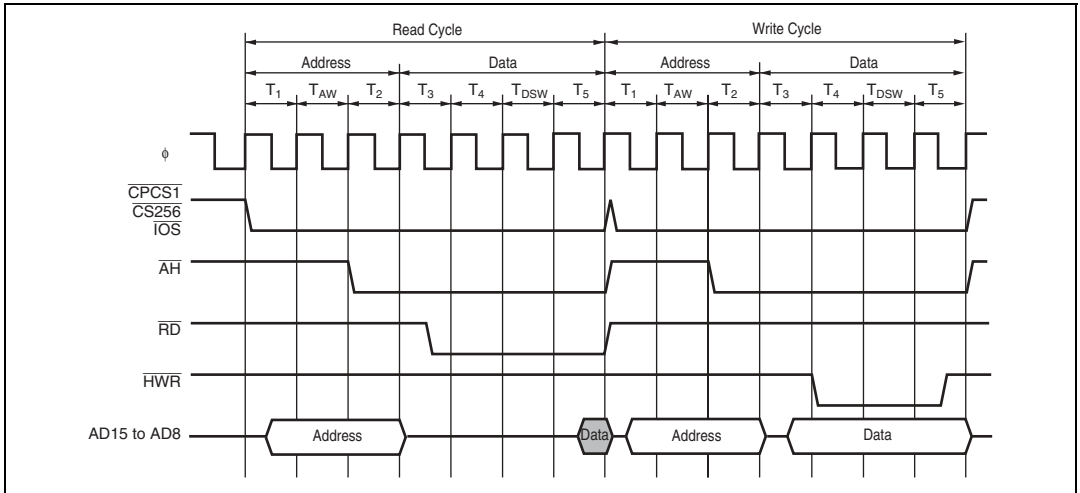

Figure 6.15 Bus Timing for 8-Bit, 3-State Access Space

(3) 16-Bit, 2-State Data Access Space: Figures 6.16 to 6.21 show bus timings for a 16-bit, 2-state access space. When a 16-bit access space is accessed, the upper half (AD15 to AD8) of the data bus is used for even addresses, and the lower half (AD7 to AD0) for odd addresses. Wait states cannot be inserted.

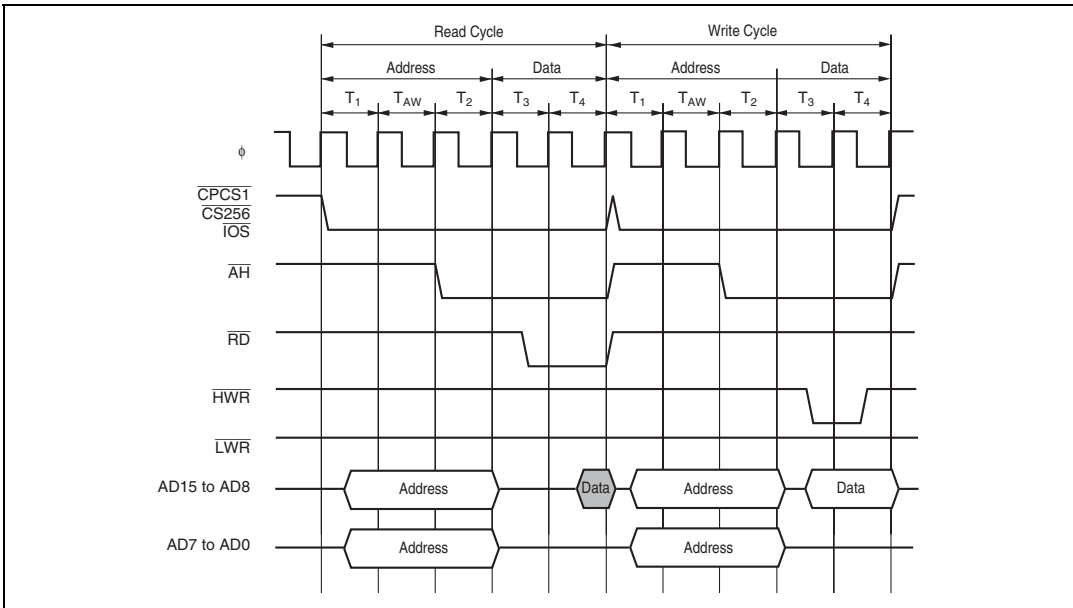

Figure 6.16 Bus Timing for 16-Bit, 2-State Access Space (1) (Even Byte Access)

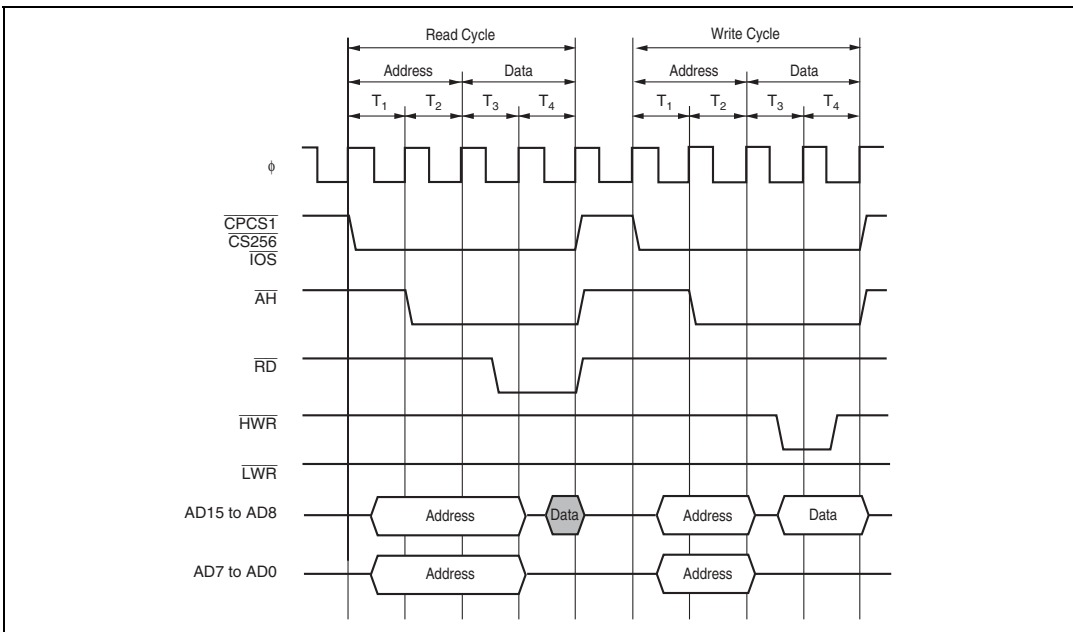

Figure 6.17 Bus Timing for 16-Bit, 2-State Access Space (2) (Even Byte Access)

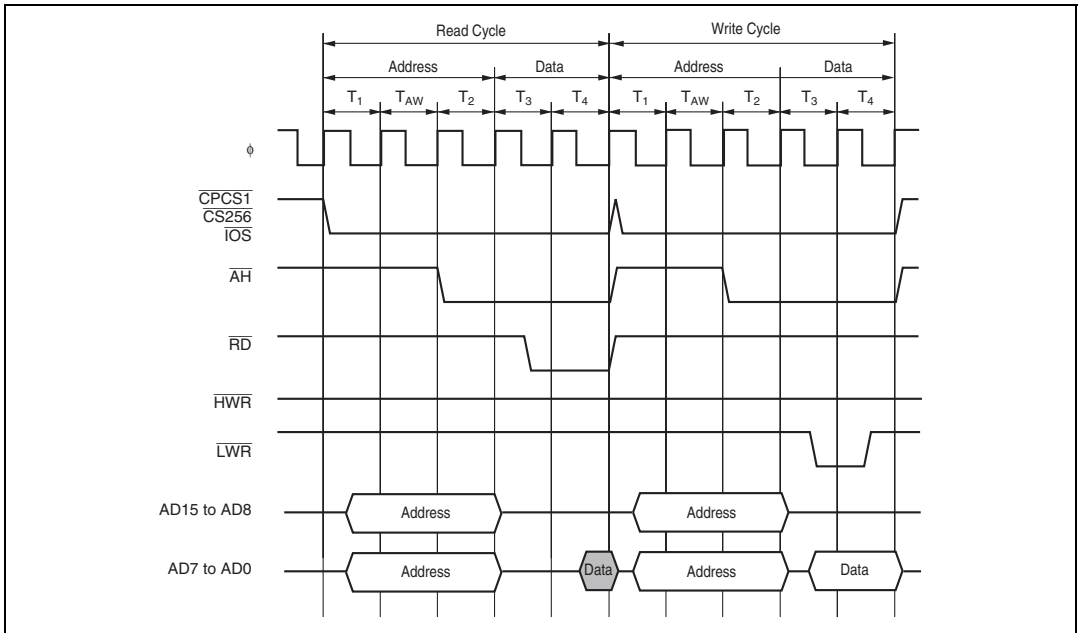

Figure 6.18 Bus Timing for 16-Bit, 2-State Access Space (3) (Odd Byte Access)

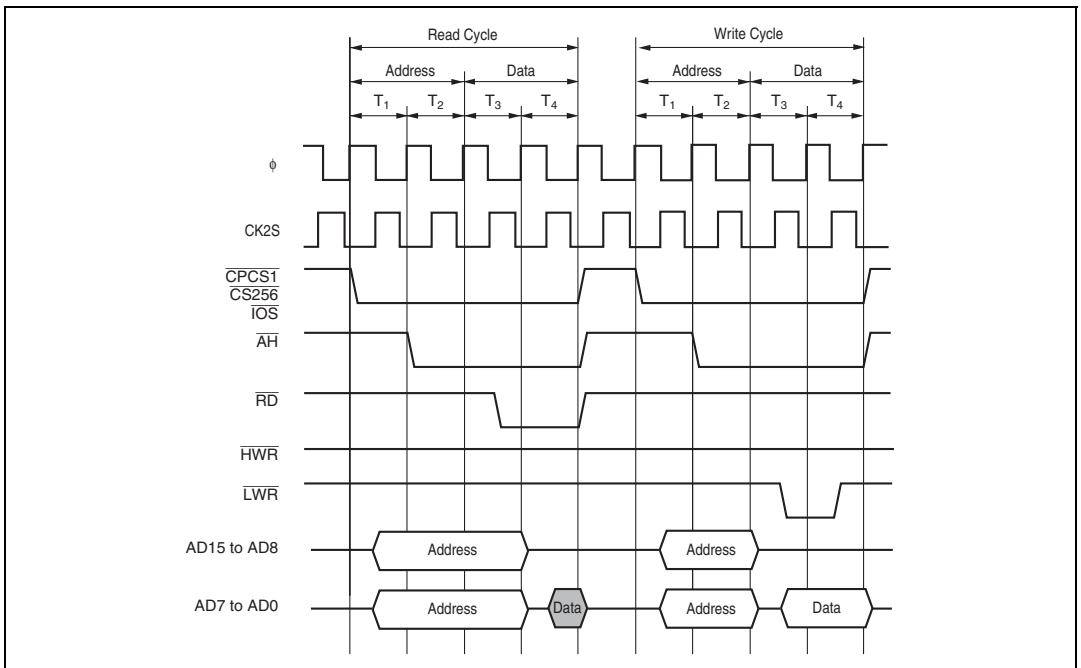

Figure 6.19 Bus Timing for 16-Bit, 2-State Access Space (4) (Odd Byte Access)

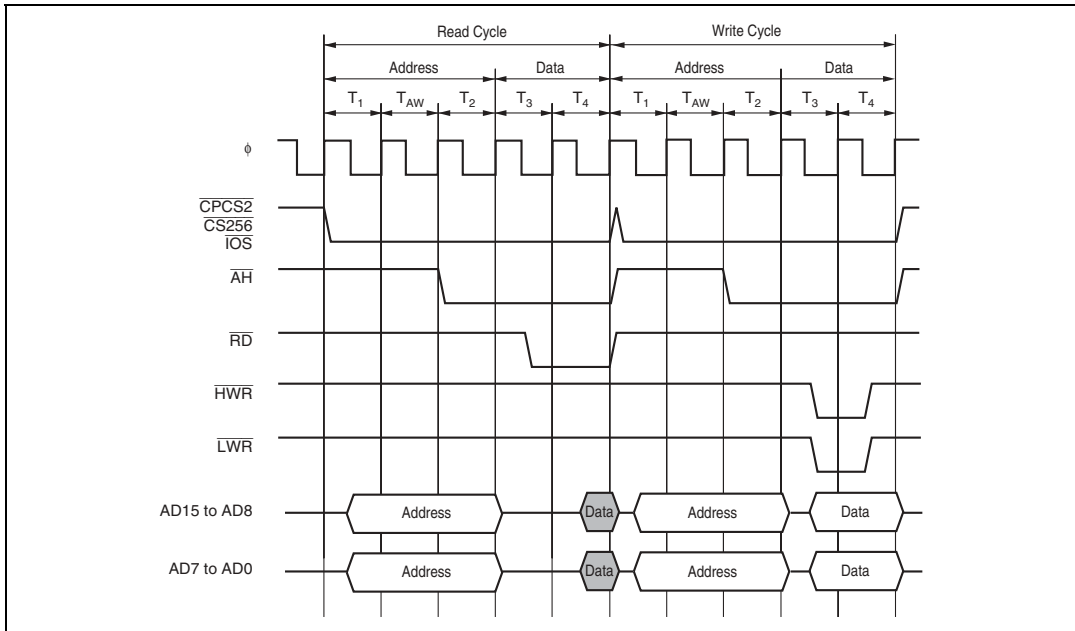

Figure 6.20 Bus Timing for 16-Bit, 2-State Access Space (5) (Word Access)

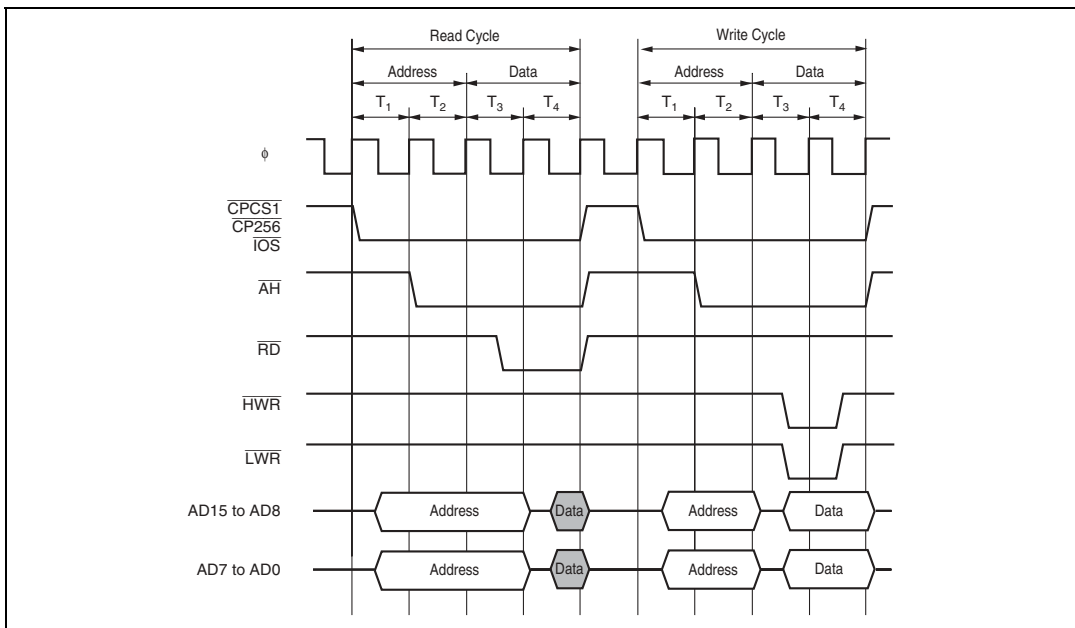

Figure 6.21 Bus Timing for 16-Bit, 2-State Access Space (6) (Word Access)

(4) 16-Bit, 3-State Data Access Space: Figures 6.22 to 6.24 show bus timings for a 16-bit, 3-state access space. When a 16-bit access space is accessed, the upper half (AD15 to AD8) of the data bus is used for even addresses, and the lower half (AD7 to AD0) for odd addresses. Wait states can be inserted.

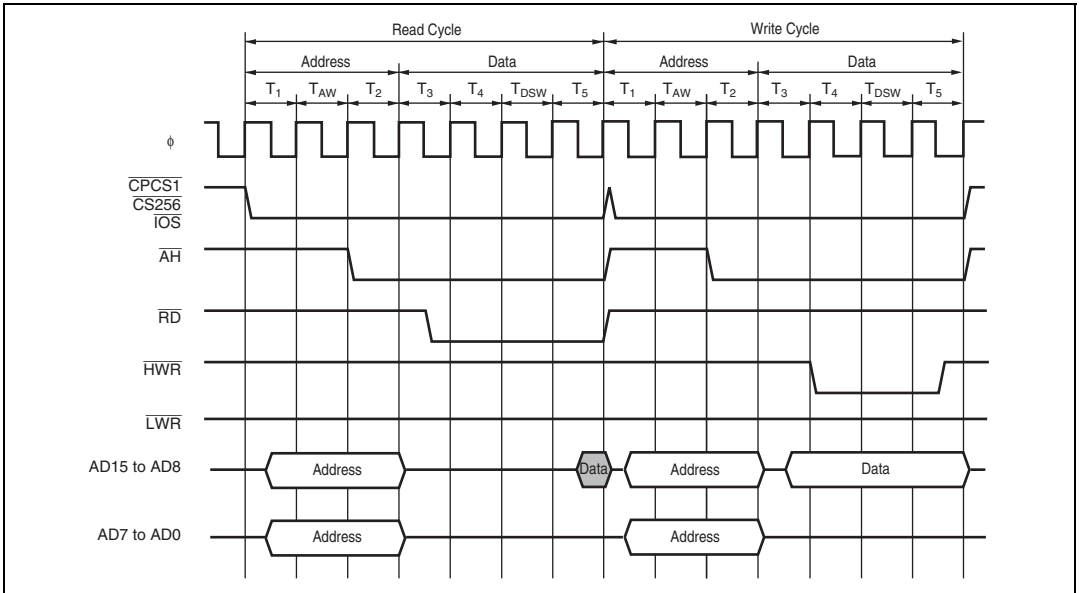

Figure 6.22 Bus Timing for 16-Bit, 3-State Access Space (1) (Even Byte Access)

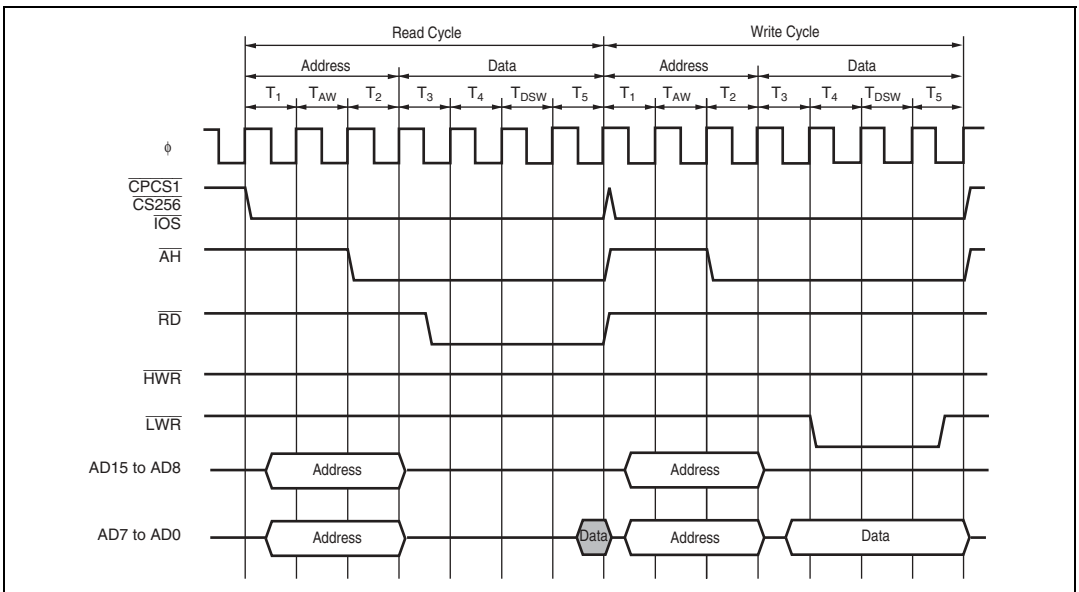

Figure 6.23 Bus Timing for 16-Bit, 3-State Access Space (2) (Odd Byte Access)

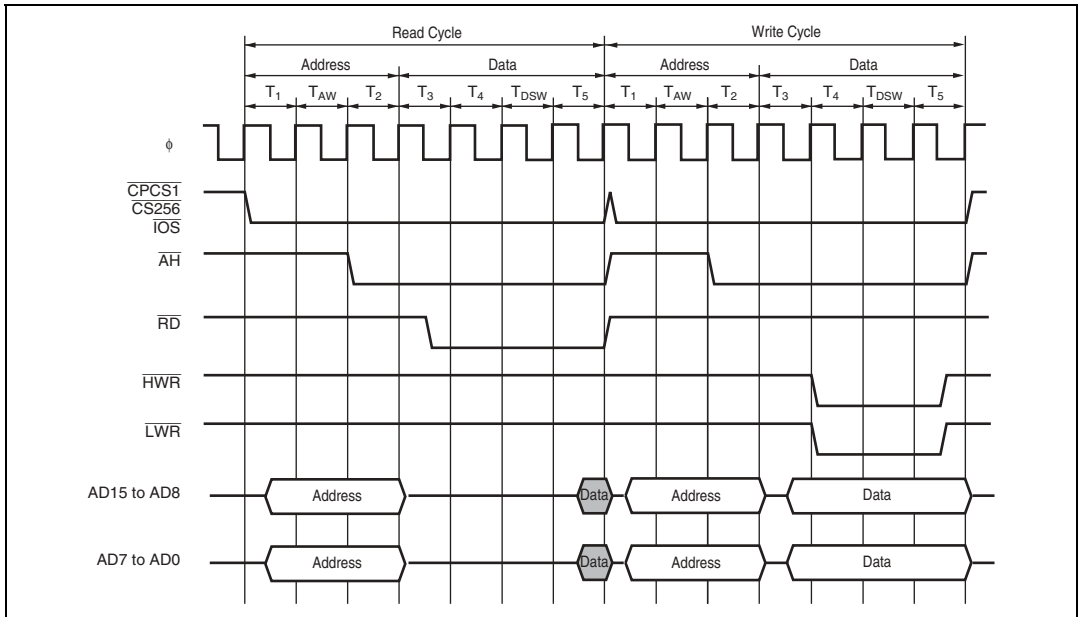

Figure 6.24 Bus Timing for 16-Bit, 3-State Access Space (3) (Word Access)

6.5.5 Wait Control

When accessing the external address space, this LSI can extend the bus cycle by inserting one or more wait states (T_w). There are three ways of inserting wait states: Program wait insertion, pin wait insertion using the $\overline{\text{WAIT}}$ pin, and the combination of program wait and the $\overline{\text{WAIT}}$ pin.

(1) In Normal Extended Mode

(a) Program Wait Mode: A specified number of wait states T_w are always inserted between the T_2 state and T_3 state when accessing the external address space. The number of wait states T_w is specified by the settings of the WC1 and WC0 bits in WSCR (the WC11 and WC10 bits in WSCR2 for the 256-kbyte extended area, and the WC21 and WC20 bits in WSCR2 for the CP extended area).

(b) Pin Wait Mode: A specified number of wait states T_w are always inserted between the T_2 state and T_3 state when accessing the external address space. The number of wait states T_w is specified by the settings of the WC1 and WC0 bits (the WC21 and WC20 bits for the CP extended area). If the $\overline{\text{WAIT}}$ pin is low at the falling edge of ϕ in the last T_2 or T_w state, another T_w state is inserted. If the $\overline{\text{WAIT}}$ pin is held low, T_w states are inserted until it goes high.

Pin wait mode is useful when inserting four or more T_w states, or when changing the number of T_w states to be inserted for each external device.

(c) **Pin Auto-Wait Mode:** A specified number of wait states T_w are inserted between the T_2 state and T_3 state when accessing the external address space if the $\overline{\text{WAIT}}$ pin is low at the falling edge of ϕ in the last T_2 state. The number of wait states T_w is specified by the settings of the WC1 and WC0 bits (the WC21 and WC20 bits for the CP extended area). Even if the $\overline{\text{WAIT}}$ pin is held low, T_w states are inserted only up to the specified number of states.

Pin auto-wait mode enables the low-speed memory interface only by inputting the chip select signal to the $\overline{\text{WAIT}}$ pin.

Figure 6.25 shows an example of wait state insertion timing in pin wait mode.

The settings after a reset are: 3-state access, 3 program wait insertion, and $\overline{\text{WAIT}}$ pin input disabled.

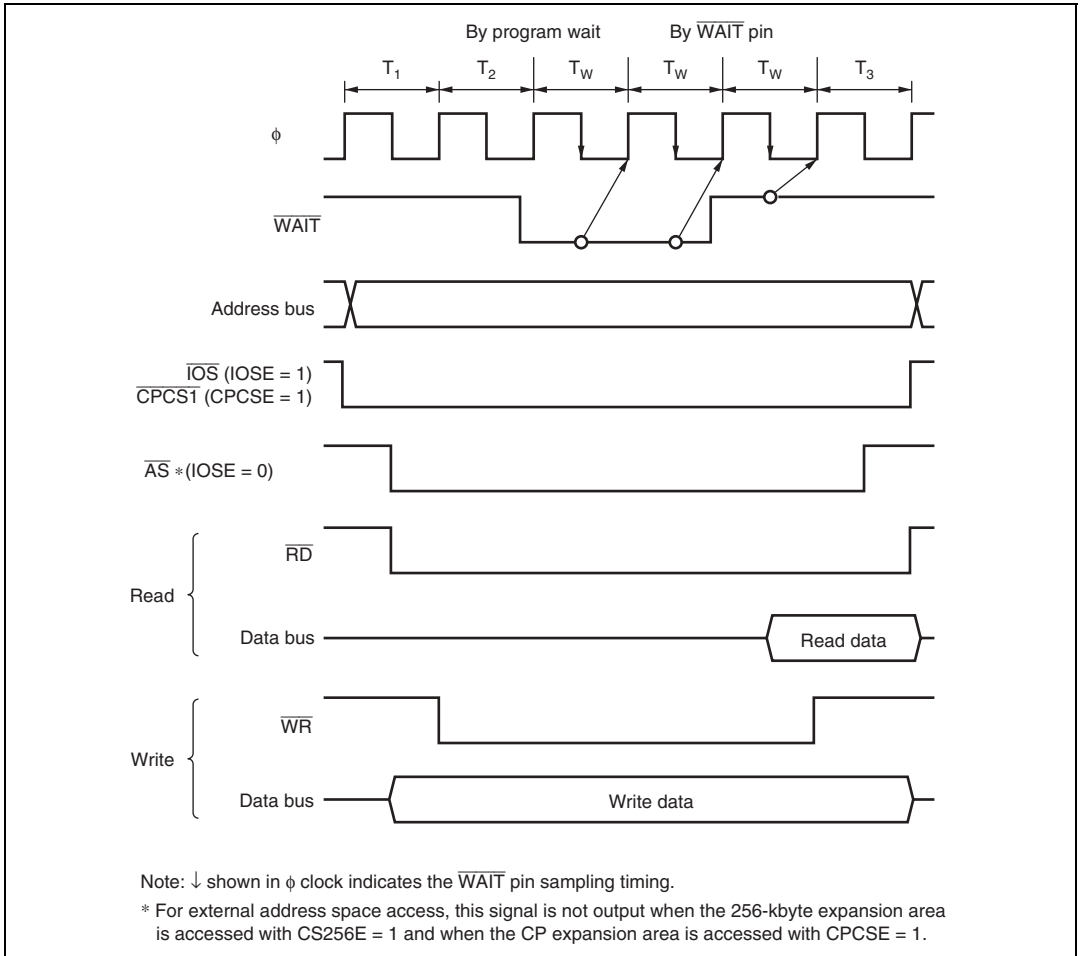

Figure 6.25 Example of Wait State Insertion Timing (Pin Wait Mode)

(2) In Address-Data Multiplex Extended Mode

(a) **Program Wait Mode:** Program wait mode includes address wait and data wait.

256-kbyte extended area and IOS extended area:

Zero or one state of address wait T_{AW} is inserted between T_1 and T_2 states. Zero to three states of data wait T_{DSW} is inserted between T_4 and T_5 states.

CP extended area:

Zero or one state of address wait T_{AW} is inserted between T_1 and T_2 states. Zero to three states of data wait T_{DSW} is inserted between T_4 and T_5 states.

(b) **Pin Wait Mode:** When accessing the external address space, a specified number of wait states T_{DSW} can be inserted between the T_4 state and T_5 state of data state. The number of wait states T_{DSW} is specified by the settings of the WC1 and WC0 bits (the WC21 and WC20 bits for the CP extended area). If the \overline{WAIT} pin is low at the falling edge of ϕ in the last T_4 , T_{DSW} , or T_{DOW} state, another T_{DOW} state is inserted. If the \overline{WAIT} pin is held low, T_{DOW} states are inserted until it goes high.

Pin wait mode is useful when inserting four or more T_{DOW} states, or when changing the number of T_{DOW} states to be inserted for each external device.

(c) **Pin Auto-Wait Mode:** A specified number of wait states T_{DOW} are inserted between the T_4 state and T_5 state when accessing the external address space if the \overline{WAIT} pin is low at the falling edge of ϕ in the last T_4 state. The number of wait states T_{DOW} is specified by the settings of the WC1 and WC0 bits (the WC21 and WC20 bits for the CP extended area). Even if the \overline{WAIT} pin is held low, T_{DOW} states are inserted only up to the specified number of states.

Pin auto-wait mode enables the low-speed memory interface only by inputting the chip select signal to the \overline{WAIT} pin.

Figure 6.26 shows an example of wait state insertion timing in pin wait mode.

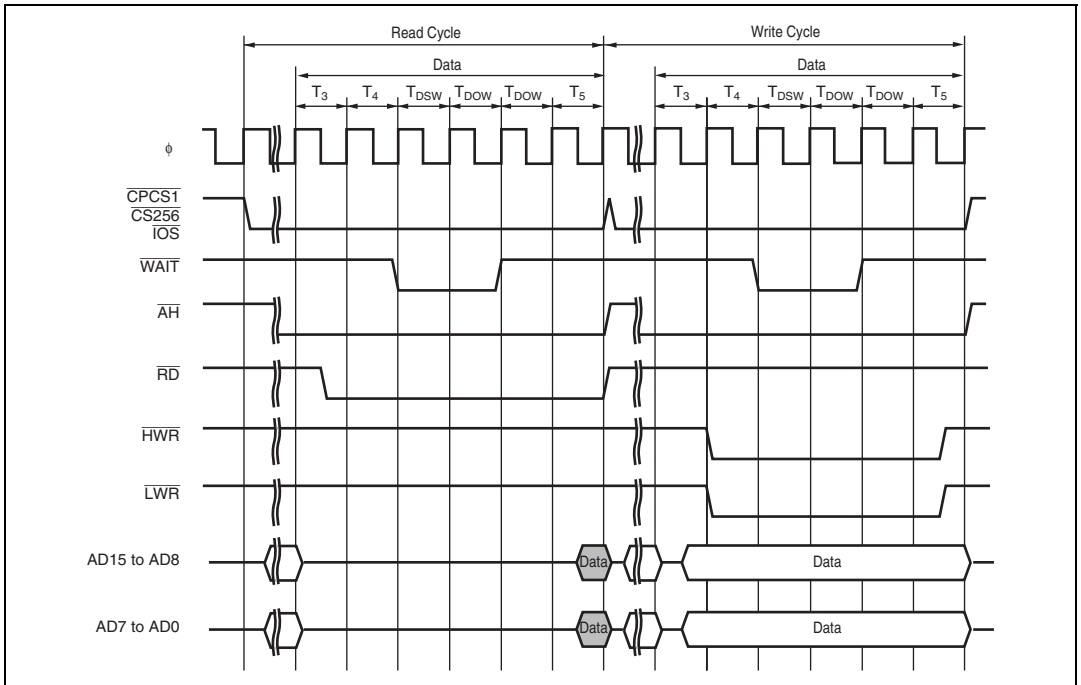

Figure 6.26 Example of Wait State Insertion Timing

6.6 Burst ROM Interface

In this LSI, the external address space can be designated as the burst ROM space by the BRSTRM bit in BCR, and the burst ROM interface enabled. Consecutive burst accesses of a maximum four or eight words can be performed only during CPU instruction fetch. 1 or 2 states can be selected for burst ROM access.

6.6.1 Basic Operation Timing

The number of access states in the initial cycle (full access) of the burst ROM interface is determined by the AST bit in WSCR. When the AST bit is set to 1, wait states can be inserted. 1 or 2 states can be selected for burst access according to the setting of the BRSTS1 bit in BCR. Wait states cannot be inserted in a burst cycle. Burst accesses of a maximum four words is performed when the BRSTS0 bit in BCR is cleared to 0, and burst accesses of a maximum eight words is performed when the BRSTS0 bit in BCR is set to 1.

The basic access timing for the burst ROM space is shown in figures 6.27 and 6.28.

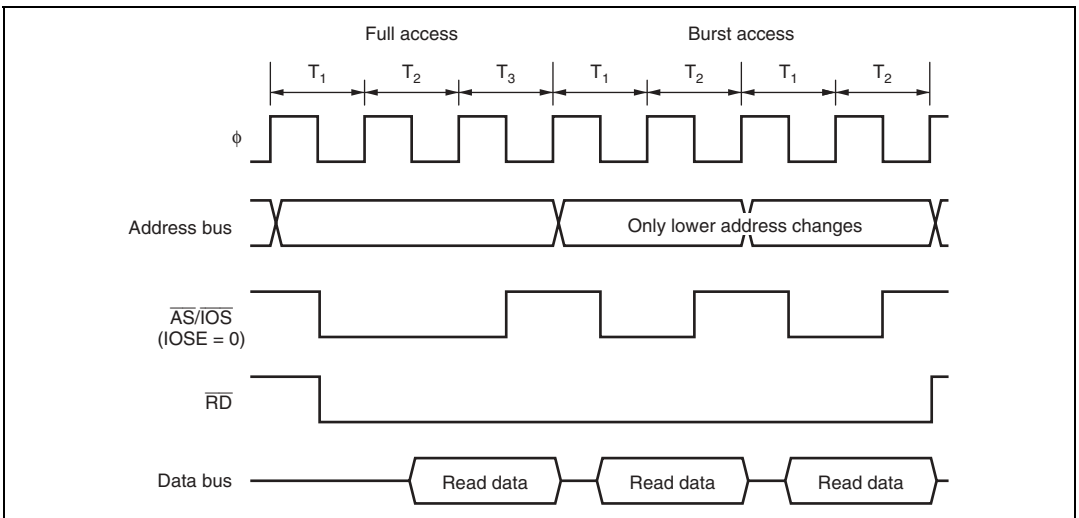

Figure 6.27 Access Timing Example in Burst ROM Space (AST = BRSTS1 = 1)

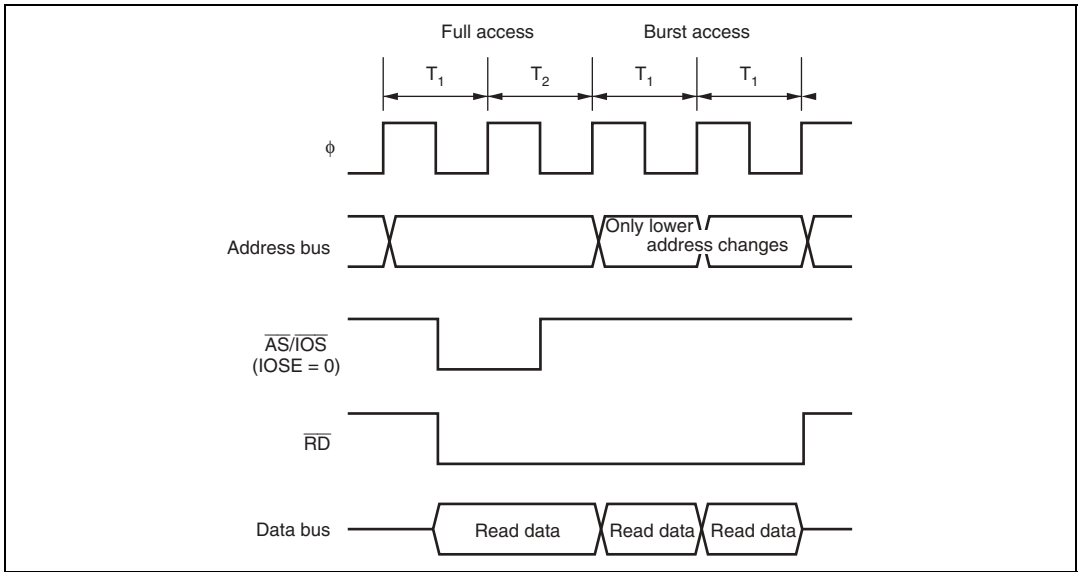

Figure 6.28 Access Timing Example in Burst ROM Space (AST = BRSTS1 = 0)

6.6.2 Wait Control

As with the basic bus interface, program wait insertion or pin wait insertion using the \overline{WAIT} pin is possible in the initial cycle (full access) of the burst ROM interface. For details, see section 6.5.5, Wait Control. Wait states cannot be inserted in a burst cycle.

6.7 Idle Cycle

When this LSI accesses the external address space, it can insert a 1-state idle cycle (T_1) between bus cycles when a write cycle occurs immediately after a read cycle. By inserting an idle cycle it is possible, for example, to avoid data collisions between ROM with a long output floating time, and high-speed memory and I/O interfaces.

If an external write occurs after an external read while the ICIS bit is set to 1 in BCR, an idle cycle is inserted at the start of the write cycle.

Figure 6.29 shows examples of idle cycle operation. In these examples, bus cycle A is a read cycle for ROM with a long output floating time, and bus cycle B is a CPU write cycle. In figure 6.29 (a), with no idle cycle inserted, a collision occurs in bus cycle B between the read data from ROM and the CPU write data. In figure 6.29 (b), an idle cycle is inserted, thus preventing data collision.

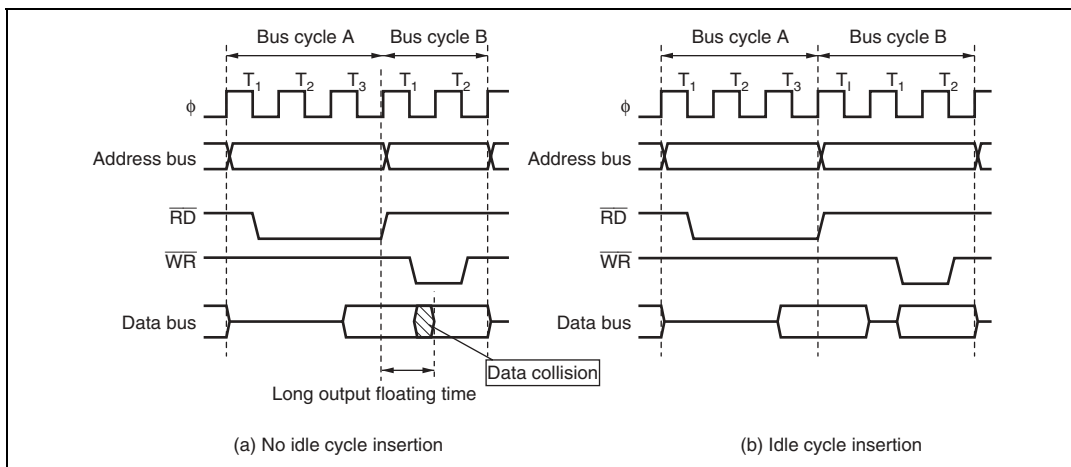

Figure 6.29 Examples of Idle Cycle Operation

Table 6.17 shows the pin states in an idle cycle.

Table 6.17 Pin States in Idle Cycle

Pins	Pin State
A23 to A0	Contents of immediately following bus cycle
D15 to D0	High impedance
\overline{AS} , \overline{IOS} , $\overline{CS256}$, $\overline{CPCS1}$	High
\overline{RD}	High
\overline{HWR} , \overline{LWR}	High

6.8 Bus Arbitration

6.8.1 Overview

The BSC has a bus arbiter that arbitrates bus master operations. There are two bus masters – the CPU and DTC – that perform read/write operations while they have bus mastership.

6.8.2 Operation

Each bus master requests the bus mastership by means of a bus mastership request signal. The bus arbiter detects the bus mastership request signal from the bus masters, and if a bus request occurs, it sends a bus mastership request acknowledge signal to the bus master that made the request at the designated timing. If there are bus requests from more than one bus master, the bus mastership request acknowledge signal is sent to the one with the highest priority. When a bus master receives the bus mastership request acknowledge signal, it takes the bus mastership until that signal is canceled. The order of bus master priority is as follows:

(High) DTC > CPU (Low)

6.8.3 Bus Mastership Transfer Timing

When a bus request is received from a bus master with a higher priority than that of the bus master that has acquired the bus mastership and is currently operating, the bus mastership is not necessarily transferred immediately. Each bus master can relinquish the bus mastership at the timings given below.

CPU: The CPU is the lowest-priority bus master, and if a bus mastership request is received from the DTC, the bus arbiter transfers the bus mastership to the DTC. The timing for transferring the bus mastership is as follows:

- Bus mastership is transferred at a break between bus cycles. However, if bus cycle is executed in discrete operations, as in the case of a long-word size access, the bus is not transferred at a break between the operations. For details see section 2.7, Bus States During Instruction Execution in the H8S/2600 Series, H8S/2000 Series Programming Manual.
- If the CPU is in sleep mode, it transfers the bus mastership immediately.

DTC: The DTC sends the bus arbiter a request for the bus mastership when a request for DTC activation occurs. The DTC releases the bus mastership after a series of processes has completed.

Section 7 Data Transfer Controller (DTC)

This LSI includes a data transfer controller (DTC). The DTC can be activated by an interrupt or software, to transfer data.

Figure 7.1 shows a block diagram of the DTC. The DTC's register information is stored in the on-chip RAM. When the DTC is used, the RAME bit in SYSCR must be set to 1. A 32-bit bus connects the DTC to addresses H'FFEC00 to H'FFEFFF in on-chip RAM (1 kbyte), enabling 32-bit/1-state reading and writing of the DTC register information.

7.1 Features

- Transfer is possible over any number of channels
- Three transfer modes
 - Normal, repeat, and block transfer modes are available
- One activation source can trigger a number of data transfers (chain transfer)
- Direct specification of 16 Mbytes address space is possible
- Activation by software is possible
- Transfer can be set in byte or word units
- A CPU interrupt can be requested for the interrupt that activated the DTC
- Module stop mode can be set
- DTC operates in high-speed mode even when the LSI is in medium-speed mode

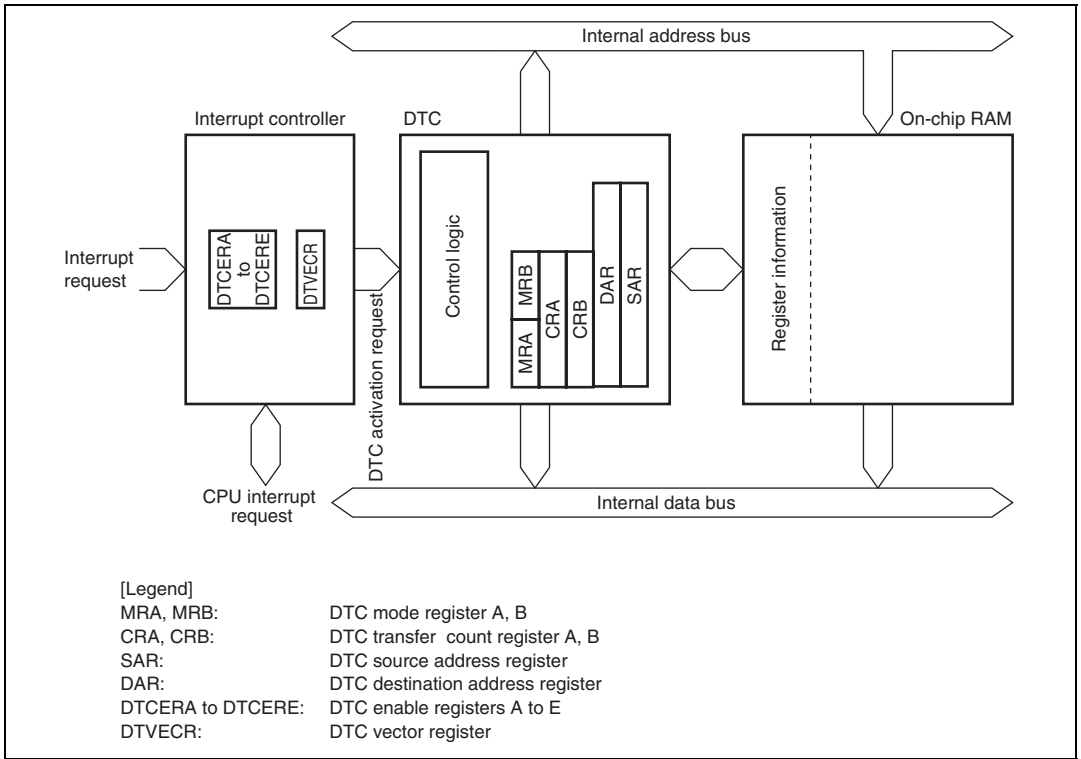

Figure 7.1 Block Diagram of DTC

7.2 Register Descriptions

The DTC has the following registers.

- DTC mode register A (MRA)
- DTC mode register B (MRB)
- DTC source address register (SAR)
- DTC destination address register (DAR)
- DTC transfer count register A (CRA)
- DTC transfer count register B (CRB)

These six registers cannot be directly accessed from the CPU. When a DTC activation interrupt source occurs, the DTC reads a set of register information that is stored in on-chip RAM to the corresponding DTC registers and transfers data. After the data transfer, it writes a set of updated register information back to on-chip RAM.

- DTC enable registers (DTCER)
- DTC vector register (DTVECR)
- Keyboard comparator control register (KBCOMP)
- Event counter control register (ECCR)
- Event counter status register (ECS)

7.2.1 DTC Mode Register A (MRA)

MRA selects the DTC operating mode.

Bit	Bit Name	Initial Value	R/W	Description
7	SM1	Undefined	—	Source Address Mode 1 and 0
6	SM0			<p>These bits specify an SAR operation after a data transfer.</p> <p>0*: SAR is fixed</p> <p>10: SAR is incremented after a transfer (by +1 when Sz = 0, by +2 when Sz = 1)</p> <p>11: SAR is decremented after a transfer (by -1 when Sz = 0, by -2 when Sz = 1)</p>
5	DM1	Undefined	—	Destination Address Mode 1 and 0
4	DM0			<p>These bits specify a DAR operation after a data transfer.</p> <p>0*: DAR is fixed</p> <p>10: DAR is incremented after a transfer (by +1 when Sz = 0, by +2 when Sz = 1)</p> <p>11: DAR is decremented after a transfer (by -1 when Sz = 0, by -2 when Sz = 1)</p>
3	MD1	Undefined	—	DTC Mode
2	MD0			<p>These bits specify the DTC transfer mode.</p> <p>00: Normal mode</p> <p>01: Repeat mode</p> <p>10: Block transfer mode</p> <p>11: Setting prohibited</p>
1	DTS	Undefined	—	<p>DTC Transfer Mode Select</p> <p>Specifies whether the source side or the destination side is set to be a repeat area or block area in repeat mode or block transfer mode.</p> <p>0: Destination side is repeat area or block area</p> <p>1: Source side is repeat area or block area</p>
0	Sz	Undefined	—	<p>DTC Data Transfer Size</p> <p>Specifies the size of data to be transferred.</p> <p>0: Byte-size transfer</p> <p>1: Word-size transfer</p>

[Legend]

*: Don't care

7.2.2 DTC Mode Register B (MRB)

MRB selects the DTC operating mode.

Bit	Bit Name	Initial Value	R/W	Description
7	CHNE	Undefined	—	DTC Chain Transfer Enable When this bit is set to 1, a chain transfer will be performed. For details, see section 7.6.4, Chain Transfer. In data transfer with CHNE set to 1, determination of the end of the specified number of data transfers, clearing of the interrupt source flag, and clearing of DTCER are not performed.
6	DISEL	Undefined	—	DTC Interrupt Select When this bit is set to 1, a CPU interrupt request is generated every time data transfer ends. When this bit is cleared to 0, a CPU interrupt request is generated only when the specified number of data transfer ends.
5 to 0	—	Undefined	—	Reserved These bits have no effect on DTC operation. The write value should always be 0.

7.2.3 DTC Source Address Register (SAR)

SAR is a 24-bit register that designates the source address of data to be transferred by the DTC. For word-size transfer, specify an even source address.

7.2.4 DTC Destination Address Register (DAR)

DAR is a 24-bit register that designates the destination address of data to be transferred by the DTC. For word-size transfer, specify an even destination address.

7.2.5 DTC Transfer Count Register A (CRA)

CRA is a 16-bit register that designates the number of times data is to be transferred by the DTC.

In normal mode, the entire CRA functions as a 16-bit transfer counter (1 to 65536). It is decremented by 1 every time data is transferred, and transfer ends when the count reaches H'0000.

In repeat mode or block transfer mode, the CRA is divided into two parts; the upper eight bits (CRAH) and the lower 8 bits (CRAL). CRAH holds the number of transfers while CRAL functions as an 8-bit transfer counter (1 to 256). CRAL is decremented by 1 every time data is transferred, and the contents of CRAH are sent when the count reaches H'00.

7.2.6 DTC Transfer Count Register B (CRB)

CRB is a 16-bit register that designates the number of times data is to be transferred by the DTC in block transfer mode. It functions as a 16-bit transfer counter (1 to 65536) that is decremented by 1 every time data is transferred, and transfer ends when the count reaches H'0000.

7.2.7 DTC Enable Registers (DTCER)

DTCER specifies DTC activation interrupt sources. DTCER is comprised of five registers: DTCERA to DTCERE. The correspondence between interrupt sources and DTCE bits is shown in tables 7.1 and 7.4. For DTCE bit setting, use bit manipulation instructions such as BSET and BCLR. Multiple DTC activation sources can be set at one time (only at the initial setting) by masking all interrupts and writing data after executing a dummy read on the relevant register.

Bit	Bit Name	Initial Value	R/W	Description
7 to 0	DTCE7 to DTCE0	All 0	R/W	<p>DTC Activation Enable</p> <p>Setting this bit to 1 specifies a relevant interrupt source as a DTC activation source.</p> <p>[Clearing conditions]</p> <ul style="list-style-type: none">• When data transfer has ended with the DISEL bit in MRB set to 1• When the specified number of transfers have ended <p>These bits are not cleared when the DISEL bit is 0 and the specified number of transfers have not been completed</p>

Table 7.1 Correspondence between Interrupt Sources and DTCER

Bit	Bit Name	Register				
		DTCERA	DTCERB	DTCERC	DTCERD	DTCERE
7	DTCEn7	(16)IRQ0	(53)OCIB	(69)CMIB1	(86)TXI1	—
6	DTCEn6	(17)IRQ1	(76)IICI2	(72)CMIAY	(89)RXI2	—
5	DTCEn5	(18)IRQ2	(94)IICI0	(73)CMIBY	(90)TXI2	—
4	DTCEn4	(19)IRQ3	—	(29)EVENTI	(78)IICI3	—
3	DTCEn3	(28)ADI	—	(44)CMIAX	(98)IICI1	(104)ERR1
2	DTCEn2	(48)ICIA	(64)CMIA0	(81)RXI0	—	(105)IBFI1
1	DTCEn1	(49)ICIB	(65)CMIB0	(82)TXI0	—	(106)IBFI2
0	DTCEn0	(52)OCIA	(68)CMIA1	(85)RXI1	(45)CMBX	(107)IBFI3

[Legend]

n: A to E

(): Vector number

—: Reserved. The write value should always be 0.

7.2.8 DTC Vector Register (DTVECR)

DTVECR enables or disables DTC activation by software, and sets a vector number for the software activation interrupt.

Bit	Bit Name	Initial Value	R/W	Description
7	SWDTE	0	R/W	<p>DTC Software Activation Enable</p> <p>Setting this bit to 1 activates DTC. Only 1 can be written to this bit.</p> <p>[Clearing conditions]</p> <ul style="list-style-type: none"> When the DISEL bit is 0 and the specified number of transfers have not ended When 0 is written to the DISEL bit after a software-activated data transfer end interrupt (SWDTEND) request has been sent to the CPU. <p>This bit will not be cleared when the DISEL bit is 1 and data transfer has ended or when the specified number of transfers has ended.</p>

Bit	Bit Name	Initial Value	R/W	Description
6 to 0	DTVEC6 to DTVEC0	All 0	R/W	<p>DTC Software Activation Vectors 6 to 0</p> <p>These bits specify a vector number for DTC software activation.</p> <p>The vector address is expressed as H'0400 + (vector number × 2). For example, when DTVEC6 to DTVEC0 = H'10, the vector address is H'0420. When the SWDTE bit is 0, these bits can be written to.</p>

7.2.9 Keyboard Comparator Control Register (KBCOMP)

KBCOMP enables or disables the comparator scan function of event counter.

Bit	Bit Name	Initial Value	R/W	Description
7	EVENTE	0	R/W	<p>Event Count Enable</p> <p>0: Disables event count function</p> <p>1: Enables event count function</p>
6, 5	—	All 0	R	<p>Reserved</p> <p>These bits are always read as 0 and cannot be modified.</p>
4 to 0	—	All 0	R/W	<p>Reserved</p> <p>The initial value should not be changed.</p>

7.2.10 Event Counter Control Register (ECCR)

ECCR selects the event counter channels for use and the detection edge.

Bit	Bit Name	Initial Value	R/W	Description
7	EDSB	0	R/W	Event Counter Edge Select Selects the detection edge for the event counter. 0: Counts the rising edges 1: Counts the falling edges
6 to 4	—	All 0	R	Reserved These bits are always read as 0 and cannot be modified.
3 to 0	ECSB3 to ECSB0	All 0	R/W	Event Counter Channel Select 3 to 0 These bits select pins for event counter input. A series of pins are selected starting from EVENT0. When PAnDDR is set to 1, inputting events to EVENT0 to EVENT7 is ignored. 0000: EVENT0 is used 0001: EVENT0 to EVENT1 are used 0010: EVENT0 to EVENT2 are used 0011: EVENT0 to EVENT3 are used 0100: EVENT0 to EVENT4 are used 0101: EVENT0 to EVENT5 are used 0110: EVENT0 to EVENT6 are used 0111: EVENT0 to EVENT7 are used 1000: EVENT0 to EVENT8 are used 1001: EVENT0 to EVENT9 are used 1010: EVENT0 to EVENT10 are used 1011: EVENT0 to EVENT11 are used 1100: EVENT0 to EVENT12 are used 1101: EVENT0 to EVENT13 are used 1110: EVENT0 to EVENT14 are used 1111: EVENT0 to EVENT15 are used

7.2.11 Event Counter Status Register (ECS)

ECS is a 16-bit register that holds events temporarily. The DTC decides the counter to be incremented according to the state of this register. Reading this register allows the monitoring of events that are not yet counted by the event counter. Access in 8-bit unit is not allowed.

Bit	Bit Name	Initial Value	R/W	Description
15 to 0	E15 to E0	0	R	Event Monitor 15 to 0 These bits indicate processed/unprocessed states of the events that are input to EVENT15 to EVENT0. 0: The corresponding event is already processed 1: The corresponding event is not yet processed

7.3 DTC Event Counter

To count events of EVENT 0 to EVENT15 by the DTC event counter function, set DTC as below.

Table 7.2 DTC Event Counter Conditions

Register	Bit	Bit Name	Description
MRA	7, 6	SM1, SM0	00: SAR is fixed.
	5, 4	DM1, DM0	00: DAR is fixed.
	3, 2	MD1, MD0	01: Repeat mode
	1	DTS	0: Destination is repeat area
	0	Sz	1: Word size transfer
MRB	7	CHNE	0: Chain transfer is disabled
	6	DISEL	0: Interrupt request is generated when data is transferred by the number of specified times
	5 to 0	—	B'000000
SAR	23 to 0	—	Identical optional RAM address. Its lower five bits are B'00000.
DAR	23 to 0	—	The start address of 16 words is this address. They are incremented every time an event is detected in EVENT0 to EVENT15.
CRAH	7 to 0	—	H'FF
CRAL	7 to 0	—	H'FF
CRBH	7 to 0	—	H'FF
CRBL	7 to 0	—	H'FF
DTCERC	4	DTCEC4	1: DTC function of the event counter is enabled
KBCOMP	7	EVENTE	1: Event counter enable
RAM	—	—	(SAR, DAR) : Result of EVENT0 count (SAR, DAR) + 2: Result of EVENT 1 count (SAR, DAR) + 4: Result of EVENT 2 count ↓ (SAR, DAR) + 30: Result of EVENT 15 count

The corresponding flag to ECS input pin is set to 1 when the event pins that are specified by the ECSB3 to ECSB0 in ECCR detect the edge events specified by the EDSB in ECCR. For this flag state, status/address codes are generated.

An EVENTI interrupt request is generated even if only one bit in ECS is set to 1.

The EVENTI interrupt request activates the DTC and transfers data from RAM to RAM in the same address. Data is incremented in the DTC. The lower five bits of SAR and DAR are replaced with address code that is generated by the ECS flag status.

When the DTC transfer is completed, the ECS flag for transfer is cleared.

Table 7.3 Flag Status/Address Code

ECS																Address Code
15	14	13	12	11	10	9	8	7	6	5	4	3	2	1	0	
															1	B'00000
														1	0	B'00010
													1	0	0	B'00100
												1	0	0	0	B'00110
											1	0	0	0	0	B'01000
										1	0	0	0	0	0	B'01010
									1	0	0	0	0	0	0	B'01100
								1	0	0	0	0	0	0	0	B'01110
							1	0	0	0	0	0	0	0	0	B'10000
						1	0	0	0	0	0	0	0	0	0	B'10010
					1	0	0	0	0	0	0	0	0	0	0	B'10100
				1	0	0	0	0	0	0	0	0	0	0	0	B'10110
			1	0	0	0	0	0	0	0	0	0	0	0	0	B'11000
		1	0	0	0	0	0	0	0	0	0	0	0	0	0	B'11010
	1	0	0	0	0	0	0	0	0	0	0	0	0	0	0	B'11100
1	0	0	0	0	0	0	0	0	0	0	0	0	0	0	0	B'11110

7.3.1 Event Counter Handling Priority

EVENT0 to EVENT15 count handling is operated in the priority shown as below.

High Low

EVENT0 > EVENT1 EVENT14 > EVENT15

7.3.2 Usage Notes

There are following usage notes for this event counter because it uses the DTC. If these usage notes are not permitted in some applications, use functions such as 8-bit timer event count.

1. Continuous events that are input from the same pin and out of DTC handling are ignored because the count up is operated by means of the DTC.
2. If some events are generated in short intervals, the priority of event counter handling is not ordered and events are not handled in order of arrival.
3. If the counter overflows, this event counter counts from H'0000 without generating an interrupt.

7.4 Activation Sources

The DTC is activated by an interrupt request or by a write to DTVECR by software. The interrupt request source to activate the DTC is selected by DTCER. At the end of a data transfer (or the last consecutive transfer in the case of chain transfer), the interrupt flag that became the activation source or the corresponding DTCER bit is cleared. The activation source flag, in the case of RXI0, for example, is the RDRF flag in SCI_0.

When an interrupt has been designated as a DTC activation source, the existing CPU mask level and interrupt controller priorities have no effect. If there is more than one activation source at the same time, the DTC operates in accordance with the default priorities. Figure 7.2 shows a block diagram of DTC activation source control. For details on the interrupt controller, see section 5, Interrupt Controller.

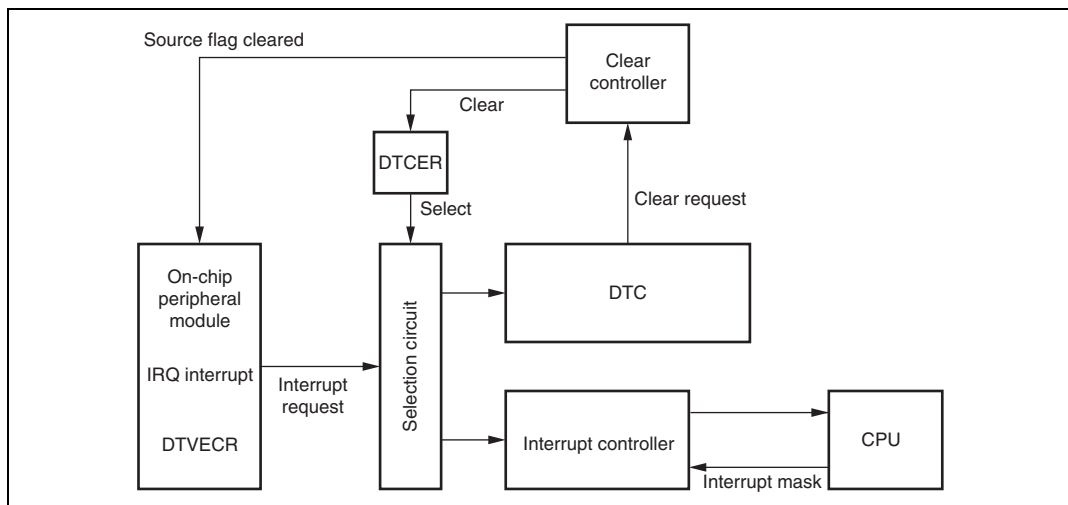

Figure 7.2 Block Diagram of DTC Activation Source Control

7.5 Location of Register Information and DTC Vector Table

Locate the register information in the on-chip RAM (addresses: H'FFEC00 to H'FFEFFF). Register information should be located at an address that is a multiple of four within the range. The method for locating the register information in address space is shown in figure 7.3. Locate MRA, SAR, MRB, DAR, CRA, and CRB, in that order, from the start address of the register information. In the case of chain transfer, register information should be located in consecutive areas as shown in figure 7.3, and the register information start address should be located at the vector address corresponding to the interrupt source in the DTC vector table. The DTC reads the start address of the register information from the vector table set for each activation source, and then reads the register information from that start address.

When the DTC is activated by software, the vector address is obtained from: $H'0400 + (DTVECR[6:0] \times 2)$. For example, if DTVECR is H'10, the vector address is H'0420.

The configuration of the vector address is a 2-byte unit. Specify the lower two bytes of the register information start address.

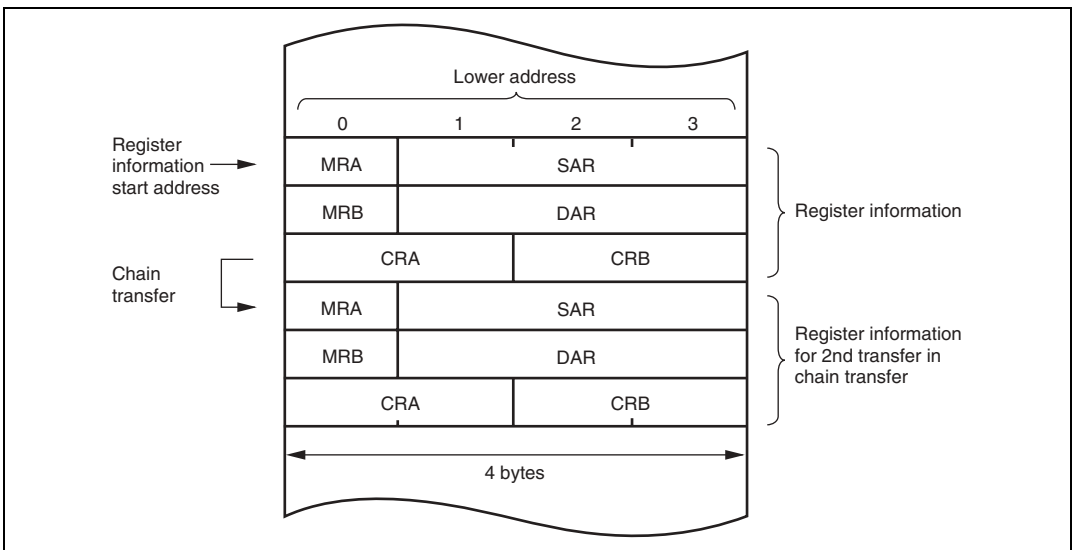

Figure 7.3 DTC Register Information Location in Address Space

Table 7.4 Interrupt Sources, DTC Vector Addresses, and Corresponding DTCEs

Activation Source Origin	Activation Source	Vector Number	DTC Vector Address	DTCE*	Priority
Software	Write to DTVECR	DTVECR	H'0400 + (vector number x 2)	—	High
External pins	IRQ0	16	H'0420	DTCEA7	↑
	IRQ1	17	H'0422	DTCEA6	
	IRQ2	18	H'0424	DTCEA5	
	IRQ3	19	H'0426	DTCEA4	
A/D converter	ADI	28	H'0438	DTCEA3	
EVC	EVENTI	29	H'043A	DTCEC4	
TMR_X	CMIA_X	44	H'0458	DTCEC3	
	CMIB_X	45	H'045A	DTCED0	
FRT	ICIA	48	H'0460	DTCEA2	
	ICIB	49	H'0462	DTCEA1	
	OCIA	52	H'0468	DTCEA0	
	OCIB	53	H'046A	DTCEB7	
TMR_0	CMIA0	64	H'0480	DTCEB2	
	CMIB0	65	H'0482	DTCEB1	
TMR_1	CMIA1	68	H'0488	DTCEB0	
	CMIB1	69	H'048A	DTCEC7	
TMR_Y	CMIAY	72	H'0490	DTCEC6	
	CMIBY	73	H'0492	DTCEC5	
IIC_2	IICI2	76	H'0498	DTCEB6	
IIC_3	IICI3	78	H'049C	DTCED4	
SCI_0	RXI0	81	H'04A2	DTCEC2	
	TXI0	82	H'04A4	DTCEC1	
SCI_1	RXI1	85	H'04AA	DTCEC0	
	TXI1	86	H'04AC	DTCED7	
SCI_2	RXI2	89	H'04B2	DTCED6	
	TXI2	90	H'04B4	DTCED5	
IIC_0	IICI0	94	H'04BC	DTCEB5	Low

Table 7.4 Interrupt Sources, DTC Vector Addresses, and Corresponding DTCEs (cont)

Activation Source Origin	Activation Source	Vector Number	DTC Vector Address	DTCE*	Priority
IIC_1	IIC1	98	H'04C4	DTCED3	High
LPC	ERRI	104	H'04D0	DTCEE3	↑ Low
	IBF1	105	H'04D2	DTCEE2	
	IBF2	106	H'04D4	DTCEE1	
	IBF3	107	H'04D6	DTCEE0	

Note: * DTCE bits with no corresponding interrupt are reserved, and the write value should always be 0.

7.6 Operation

The DTC stores register information in on-chip RAM. When activated, the DTC reads register information in on-chip RAM and transfers data. After the data transfer, the DTC writes updated register information back to on-chip RAM. The pre-storage of register information in memory makes it possible to transfer data over any required number of channels. The transfer mode can be specified as normal, repeat, or block transfer mode. Setting the CHNE bit in MRB to 1 makes it possible to perform a number of transfers with a single activation source (chain transfer).

The 24-bit SAR designates the DTC transfer source address, and the 24-bit DAR designates the transfer destination address. After each transfer, SAR and DAR are independently incremented, decremented, or left fixed depending on its register information.

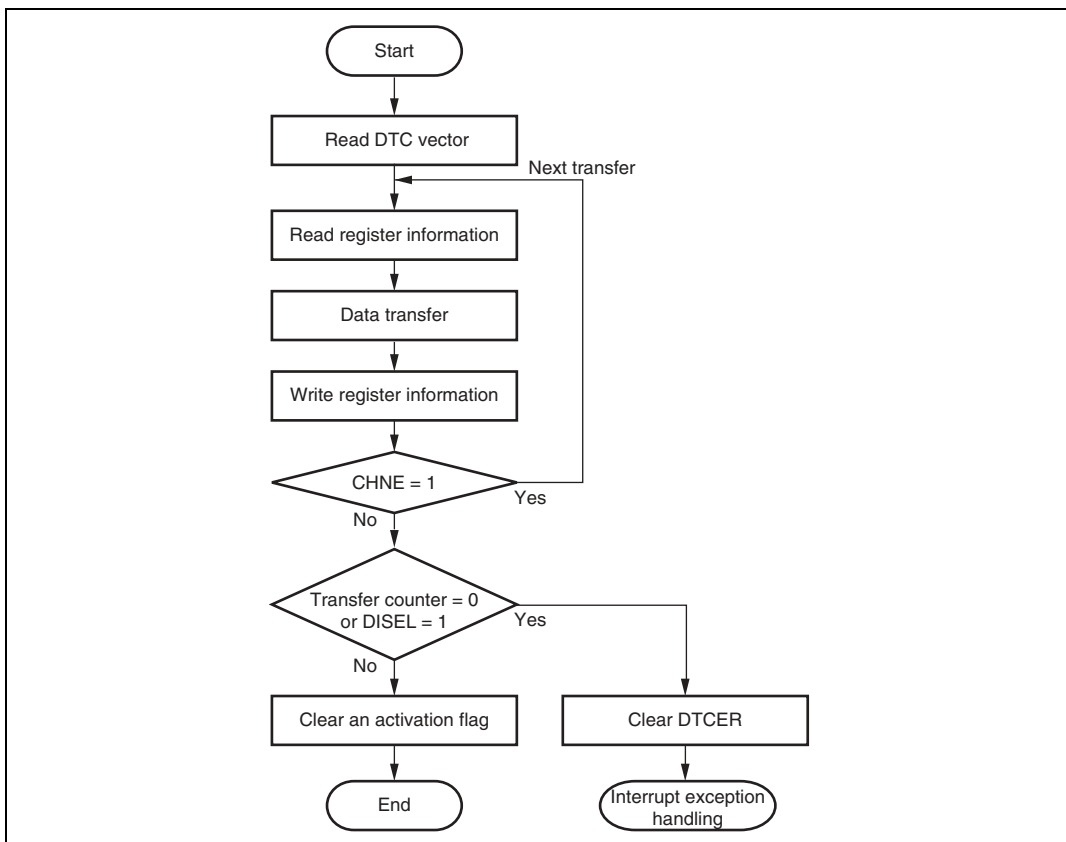

Figure 7.4 DTC Operation Flowchart

7.6.1 Normal Mode

In normal mode, one activation source transfers one byte or one word of data. Table 7.5 lists the register functions in normal mode. From 1 to 65,536 transfers can be specified. Once the specified number of transfers has been completed, a CPU interrupt can be requested.

Table 7.5 Register Functions in Normal Mode

Name	Abbreviation	Function
DTC source address register	SAR	Transfer source address
DTC destination address register	DAR	Transfer destination address
DTC transfer count register A	CRA	Transfer counter
DTC transfer count register B	CRB	Not used

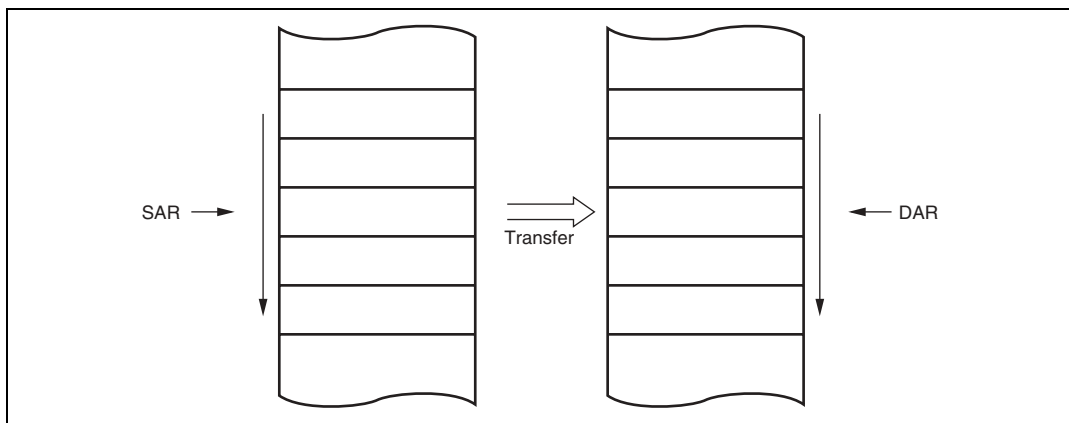

Figure 7.5 Memory Mapping in Normal Mode

7.6.2 Repeat Mode

In repeat mode, one activation source transfers one byte or one word of data. Table 7.6 lists the register functions in repeat mode. From 1 to 256 transfers can be specified. Once the specified number of transfers has been completed, the initial states of the transfer counter and the address register that is specified as the repeat area is restored, and transfer is repeated. In repeat mode, the transfer counter value does not reach H'00, and therefore CPU interrupts cannot be requested when the DISEL bit in MRB is cleared to 0.

Table 7.6 Register Functions in Repeat Mode

Name	Abbreviation	Function
DTC source address register	SAR	Transfer source address
DTC destination address register	DAR	Transfer destination address
DTC transfer count register AH	CRAH	Holds number of transfers
DTC transfer count register AL	CRAL	Transfer Count
DTC transfer count register B	CRB	Not used

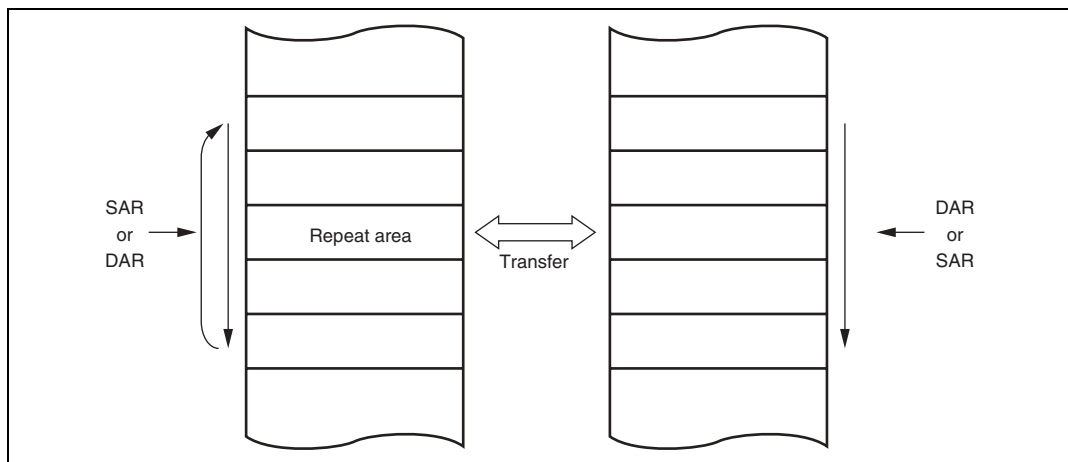

Figure 7.6 Memory Mapping in Repeat Mode

7.6.3 Block Transfer Mode

In block transfer mode, one activation source transfers one block of data. Either the transfer source or the transfer destination is designated as a block area. Table 7.7 lists the register functions in block transfer mode. The block size can be between 1 and 256. When the transfer of one block ends, the initial state of the block size counter and the address register that is specified as the block area is restored. The other address register is then incremented, decremented, or left fixed according to the register information. From 1 to 65,536 transfers can be specified. Once the specified number of transfers has been completed, a CPU interrupt is requested.

Table 7.7 Register Functions in Block Transfer Mode

Name	Abbreviation	Function
DTC source address register	SAR	Transfer source address
DTC destination address register	DAR	Transfer destination address
DTC transfer count register AH	CRAH	Holds block size
DTC transfer count register AL	CRAL	Block size counter
DTC transfer count register B	CRB	Transfer counter

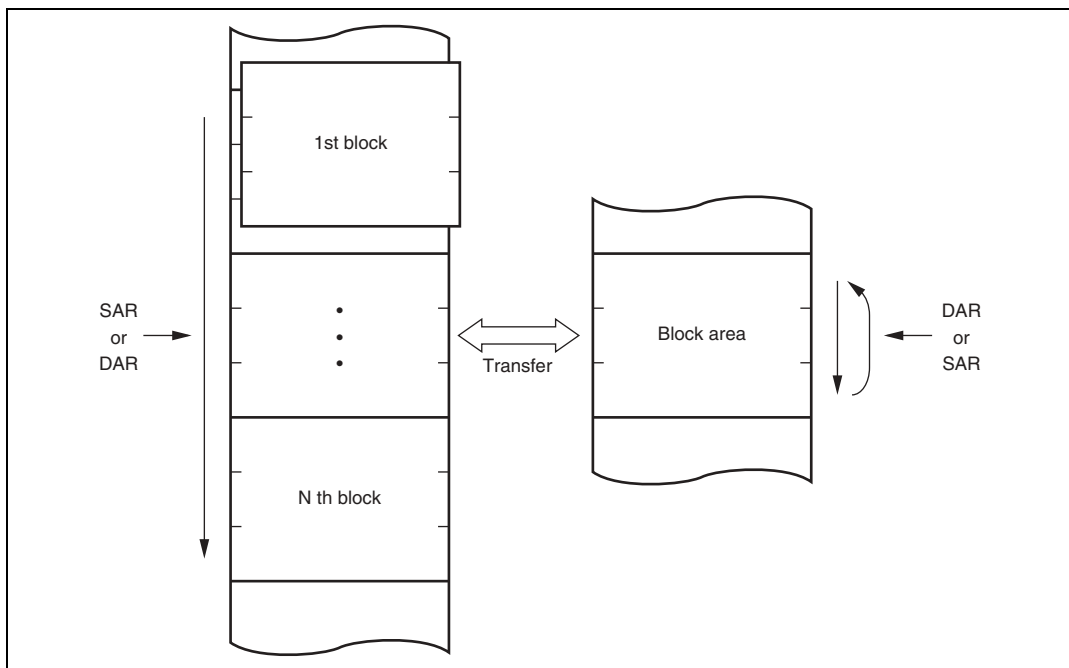

Figure 7.7 Memory Mapping in Block Transfer Mode

7.6.4 Chain Transfer

Setting the CHNE bit in MRB to 1 enables a number of data transfers to be performed consecutively in response to a single transfer request. SAR, DAR, CRA, CRB, MRA, and MRB, which define data transfers, can be set independently.

Figure 7.8 shows the overview of chain transfer operation. When activated, the DTC reads the register information start address stored at the DTC vector address, and then reads the first register information at that start address. After the data transfer, the CHNE bit will be tested. When it has been set to 1, DTC reads the next register information located in a consecutive area and performs the data transfer. These sequences are repeated until the CHNE bit is cleared to 0.

In the case of transfer with the CHNE bit set to 1, an interrupt request to the CPU is not generated at the end of the specified number of transfers or by setting of the DISEL bit to 1, and the interrupt source flag for the activation source is not affected.

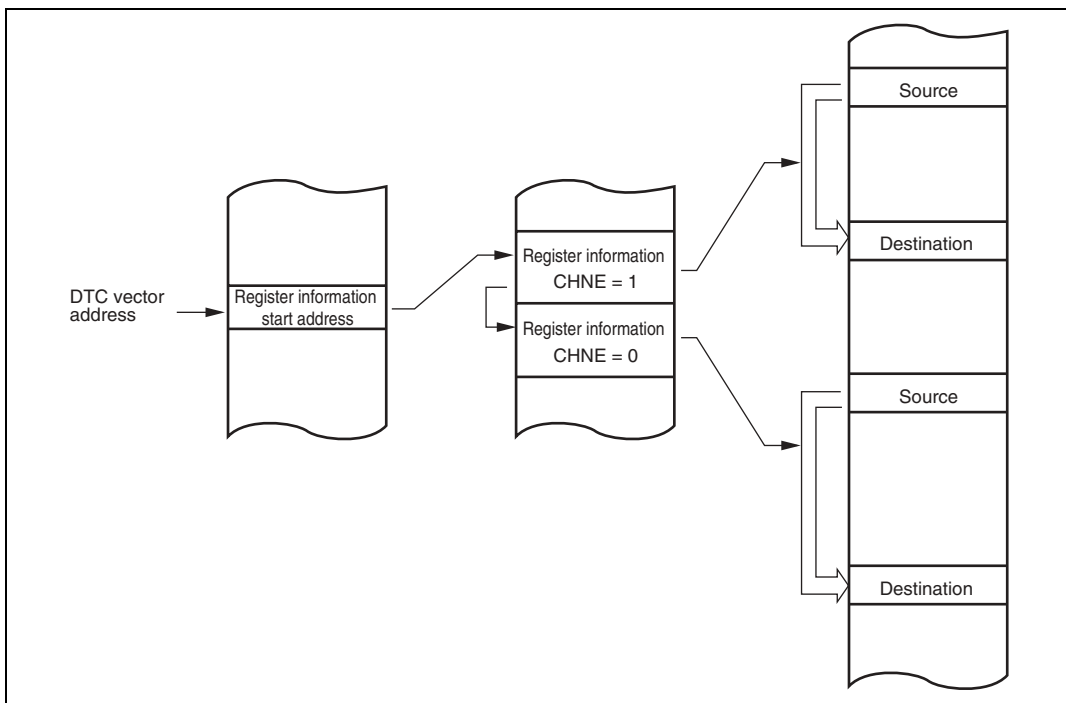

Figure 7.8 Chain Transfer Operation

7.6.5 Interrupt Sources

An interrupt request is issued to the CPU when the DTC has completed the specified number of data transfers, or a data transfer for which the DIESEL bit was set to 1. In the case of interrupt activation, the interrupt set as the activation source is generated. These interrupts to the CPU are subject to CPU mask level and priority level control by the interrupt controller.

In the case of software activation, a software-activated data transfer end interrupt (SWDTEND) is generated.

When the DIESEL bit is 1 and one data transfer has been completed, or the specified number of transfers have been completed, after data transfer ends, the SWDTE bit is held at 1 and an SWDTEND interrupt is generated. The interrupt handling routine will then clear the SWDTE bit to 0.

When the DTC is activated by software, an SWDTEND interrupt is not generated during a data transfer wait or during data transfer even if the SWDTE bit is set to 1.

7.6.6 Operation Timing

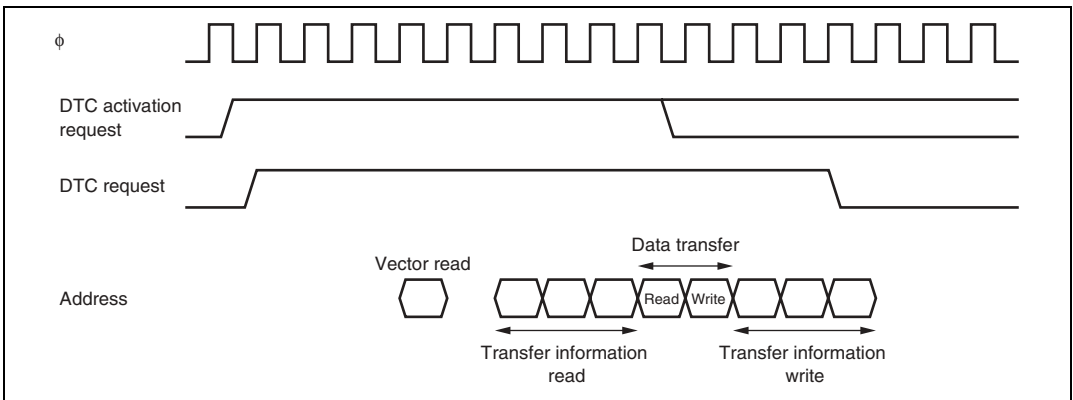

Figure 7.9 DTC Operation Timing (Example in Normal Mode or Repeat Mode)

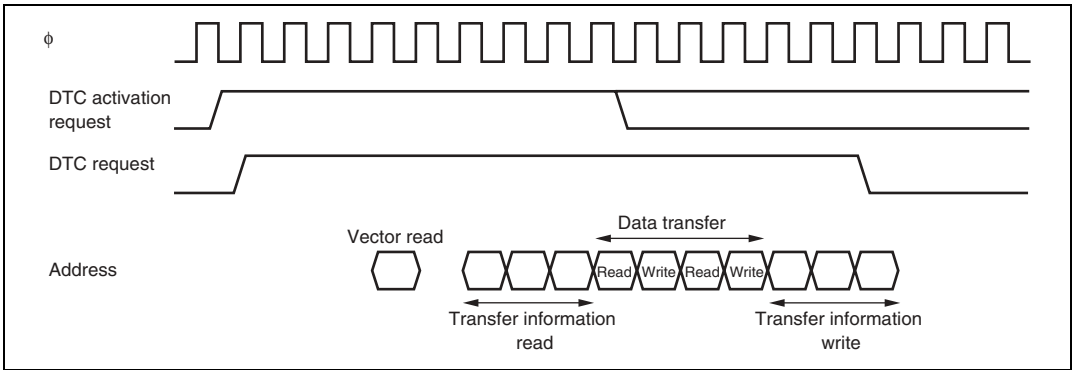

Figure 7.10 DTC Operation Timing (Example of Block Transfer Mode, with Block Size of 2)

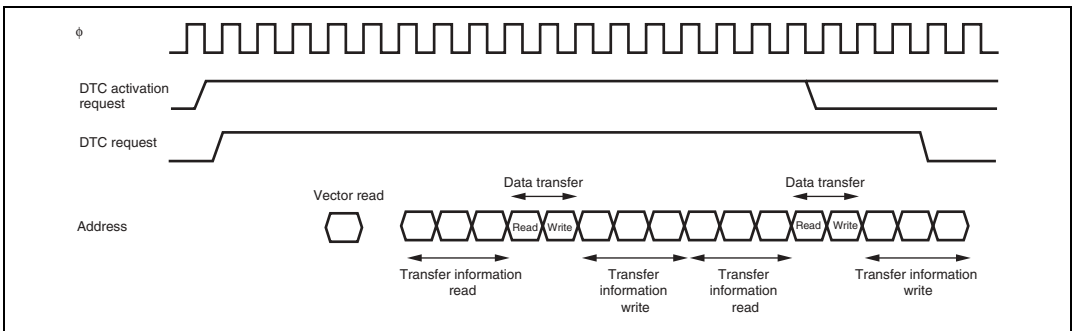

Figure 7.11 DTC Operation Timing (Example of Chain Transfer)

7.6.7 Number of DTC Execution States

Table 7.8 lists the execution status for a single DTC data transfer, and table 7.9 shows the number of states required for each execution status.

Table 7.8 DTC Execution Status

Mode	Vector Read I	Register Information Read/Write J	Data Read K	Data Write L	Internal Operations M
Normal	1	6	1	1	3
Repeat	1	6	1	1	3
Block transfer	1	6	N	N	3

[Legend]

N: Block size (initial setting of CRAH and CRAL)

Table 7.9 Number of States Required for Each Execution Status

Object to be Accessed	On-Chip RAM		On-Chip ROM	On-Chip I/O Registers		External Devices				
	On-Chip RAM (H'FFEC00 to H'FFEEFF)	(On-chip RAM area other than H'FFEC00 to H'FFEEFF)		On-Chip I/O Registers	External Devices					
Bus width	32	16	16	8	16	8	8	16	16	
Access states	1	1	1	2	2	2	3	2	3	
Execution status	Vector read S_i	—	—	1	—	—	4	6 + 2m	2	3 + m
	Register information read/write S_j	1	—	—	—	—	—	—	—	—
	Byte data read S_k	1	1	1	2	2	2	3 + m	2	3 + m
	Word data read S_k	1	1	1	4	2	4	6 + 2m	2	3 + m
	Byte data write S_l	1	1	1	2	2	2	3 + m	2	3 + m
	Word data write S_l	1	1	1	4	2	4	6 + 2m	2	3 + m
	Internal operation S_m	1	1	1	1	1	1	1	1	1

The number of execution states is calculated from using the formula below. Note that Σ is the sum of all transfers activated by one activation source (the number in which the CHNE bit is set to 1, plus 1).

$$\text{Number of execution states} = I \cdot S_i + \Sigma (J \cdot S_j + K \cdot S_k + L \cdot S_l) + M \cdot S_m$$

For example, when the DTC vector address table is located in on-chip ROM, normal mode is set, and data is transferred from on-chip ROM to an internal I/O register, then the time required for the DTC operation is 13 states. The time from activation to the end of data write is 10 states.

7.7 Procedures for Using DTC

7.7.1 Activation by Interrupt

The procedure for using the DTC with interrupt activation is as follows:

- [1] Set the MRA, MRB, SAR, DAR, CRA, and CRB register information in on-chip RAM.
- [2] Set the start address of the register information in the DTC vector address.
- [3] Set the corresponding bit in DTCE to 1.
- [4] Set the enable bits for the interrupt sources to be used as the activation sources to 1. The DTC is activated when an interrupt used as an activation source is generated.
- [5] After one data transfer has been completed, or after the specified number of data transfers have been completed, the DTCE bit is cleared to 0 and a CPU interrupt is requested. If the DTC is to continue transferring data, set the DTCE bit to 1.

7.7.2 Activation by Software

The procedure for using the DTC with software activation is as follows:

- [1] Set the MRA, MRB, SAR, DAR, CRA, and CRB register information in on-chip RAM.
- [2] Set the start address of the register information in the DTC vector address.
- [3] Check that the SWDTE bit is 0.
- [4] Write 1 to the SWDTE bit and the vector number to DTVECR.
- [5] Check the vector number written to DTVECR.
- [6] After one data transfer has been completed, if the DISEL bit is 0 and a CPU interrupt is not requested, the SWDTE bit is cleared to 0. If the DTC is to continue transferring data, set the SWDTE bit to 1. When the DISEL bit is 1 or after the specified number of data transfers have been completed, the SWDTE bit is held at 1 and a CPU interrupt is requested.

7.8 Examples of Use of the DTC

7.8.1 Normal Mode

An example is shown in which the DTC is used to receive 128 bytes of data via the SCI.

- [1] Set MRA to a fixed source address ($SM1 = SM0 = 0$), incrementing destination address ($DM1 = 1, DM0 = 0$), normal mode ($MD1 = MD0 = 0$), and byte size ($Sz = 0$). The DTS bit can have any value. Set MRB for one data transfer by one interrupt ($CHNE = 0, DISEL = 0$). Set the SCI, RDR address in SAR, the start address of the RAM area where the data will be received in DAR, and 128 (H'0080) in CRA. CRB can be set to any value.
- [2] Set the start address of the register information at the DTC vector address.
- [3] Set the corresponding bit in DTCER to 1.
- [4] Set the SCI to the appropriate receive mode. Set the RIE bit in SCR to 1 to enable the reception complete (RXI) interrupt. Since the generation of a receive error during the SCI reception operation will disable subsequent reception, the CPU should be enabled to accept receive error interrupts.
- [5] Each time the reception of one byte of data has been completed on the SCI, the RDRF flag in SSR is set to 1, an RXI interrupt is generated, and the DTC is activated. The receive data is transferred from RDR to RAM by the DTC. DAR is incremented and CRA is decremented. The RDRF flag is automatically cleared to 0.
- [6] When CRA becomes 0 after 128 data transfers have been completed, the RDRF flag is held at 1, the DTCE bit is cleared to 0, and an RXI interrupt request is sent to the CPU. The interrupt handling routine will perform wrap-up processing.

7.8.2 Software Activation

An example is shown in which the DTC is used to transfer a block of 128 bytes of data by means of software activation. The transfer source address is H'1000 and the transfer destination address is H'2000. The vector number is H'60, so the vector address is H'04C0.

- [1] Set MRA to incrementing source address ($SM1 = 1, SM0 = 0$), incrementing destination address ($DM1 = 1, DM0 = 0$), block transfer mode ($MD1 = 1, MD0 = 0$), and byte size ($Sz = 0$). The DTS bit can have any value. Set MRB for one block transfer by one interrupt ($CHNE = 0$). Set the transfer source address (H'1000) in SAR, the transfer destination address (H'2000) in DAR, and 128 (H'8080) in CRA. Set 1 (H'0001) in CRB.
- [2] Set the start address of the register information at the DTC vector address (H'04C0).
- [3] Check that the SWDTE bit in DTVECR is 0. Check that there is currently no transfer activated by software.
- [4] Write 1 to the SWDTE bit and the vector number (H'60) to DTVECR. The write data is H'E0.

- [5] Read DTVECR again and check that it is set to the vector number (H'60). If it is not, this indicates that the write failed. This is presumably because an interrupt occurred between steps 3 and 4 and led to a different software activation. To activate this transfer, go back to step 3.
- [6] If the write was successful, the DTC is activated and a block of 128 bytes of data is transferred.
- [7] After the transfer, an SWDTEND interrupt occurs. The interrupt handling routine should clear the SWDTE bit to 0 and perform wrap-up processing.

7.9 Usage Notes

7.9.1 Module Stop Mode Setting

DTC operation can be enabled or disabled by the module stop control register (MSTPCR). In the initial state, DTC operation is enabled. Access to DTC registers are disabled when module stop mode is set. Note that when the DTC is being activated, module stop mode can not be specified. For details, refer to section 23, Power-Down Modes.

7.9.2 On-Chip RAM

MRA, MRB, SAR, DAR, CRA, and CRB are all located in on-chip RAM. When the DTC is used, the RAME bit in SYSCR should not be cleared to 0.

7.9.3 DTCE Bit Setting

For DTCE bit setting, use bit manipulation instructions such as BSET and BCLR, for reading and writing. Multiple DTC activation sources can be set at one time (only at the initial setting) by masking all interrupts and writing data after executing a dummy read on the relevant register.

7.9.4 Setting Required on Entering Subactive Mode or Watch Mode

Set the MSTP14 bit in MSTPCRH to 1 to make the DTC enter module stop mode, then confirm that is set to 1 before making a transition to subactive mode or watch mode.

7.9.5 DTC Activation by Interrupt Sources of SCI, IIC, or A/D Converter

Interrupt sources of the SCI, IIC, or A/D converter which activate the DTC are cleared when DTC reads from or writes to the respective registers, and they cannot be cleared by the DISEL bit in MRB.

Section 8 I/O Ports

Table 8.1 is a summary of the port functions. The pins of each port also function as input/output pins of peripheral modules and interrupt input pins. Each input/output port includes a data direction register (DDR) that controls input/output and a data register (DR) that stores output data. DDR and DR are not provided for an input-only port.

Ports 1 to 3, 6, A, and D0 to D5 have built-in input pull-up MOSs. For port A and D0 to D5, the on/off status of the input pull-up MOS is controlled by DDR and ODR. Ports 1 to 3 and 6 have an input pull-up MOS control register (PCR), in addition to DDR and DR, to control the on/off status of the input pull-up MOSs.

Ports 1 to 6, and 8 to F can drive a single TTL load and 30 pF capacitive load. All the I/O ports can drive a Darlington transistor in output mode. Ports 8, C0 to C5 and D6 to D7 are NMOS push-pull output.

Table 8.1 Port Functions

Port	Description	Extended Mode (EXPE = 1)	Single-Chip Mode (EXPE = 0)	I/O Status
Port 1	General I/O port also functioning as PWM output, address output, and address/data multiplex input/output	P17/A7/AD7	P17/PW7	Built-in input pull-up MOSs LED drive capability (sink current 5 mA)
		P16/A6/AD6	P16/PW6	
		P15/A5/AD5	P15/PW5	
		P14/A4/AD4	P14/PW4	
		P13/A3/AD3	P13/PW3	
		P12/A2/AD2	P12/PW2	
		P11/A1/AD1	P11/PW1	
Port 2	General I/O port also functioning as PWM output, address output, and address/data multiplex input/output	P27/A15/AD15	P27/PW15	Built-in input pull-up MOSs LED drive capability (sink current 5 mA)
		P26/A14/AD14	P26/PW14	
		P25/A13/AD13	P25/PW13	
		P24/A12/AD12	P24/PW12	
		P23/A11/AD11	P23/PW11	
		P22/A10/AD10	P22/PW10	
		P21/A9/AD9	P21/PW9	
	P20/A8/AD8	P20/PW8		

Table 8.1 Port Functions (cont)

Port	Description	Extended Mode (EXPE = 1)	Single-Chip Mode (EXPE = 0)	I/O Status
Port 3	General I/O port also functioning as bidirectional data bus, and wake-up event input	P37/D15/ $\overline{WVEI5}$	P37/ $\overline{WUE15}$	Built-in input pull-up MOSs LED drive capability (sink current 5 mA)
		P36/D14/ $\overline{WUEI4}$	P36/ $\overline{WUE14}$	
		P35/D13/ $\overline{WUEI3}$	P35/ $\overline{WUE13}$	
		P34/D12/ $\overline{WUEI2}$	P34/ $\overline{WUE12}$	
		P33/D11/ $\overline{WUEI1}$	P33/ $\overline{WUE11}$	
		P32/D10/ $\overline{WUEI0}$	P32/ $\overline{WUE10}$	
		P31/D9/ $\overline{WUEI9}$	P31/ $\overline{WUE9}$	
Port 4	General I/O port also functioning as interrupt input, and TMR_0, TMR_1, TMR_X, TMR_Y input	P47/ $\overline{IRQ7}$ /TMOY		
		P46/ $\overline{IRQ6}$ /TMOX		
		P45/ $\overline{IRQ5}$ /TMIY		
		P44/ $\overline{IRQ4}$ /TMIX		
		P43/ $\overline{IRQ3}$ /TMO1		
		P42/ $\overline{IRQ2}$ /TMO0		
Port 5	General I/O port also functioning as interrupt input, PWMX output, and SCI_0, SCI_1, SCI_2 I/O pins	P41/ $\overline{IRQ1}$ /TMI1		
		P40/ $\overline{IRQ0}$ /TMI0		
		P57/ $\overline{IRQ15}$ /PWX1		
		P56/ $\overline{IRQ14}$ /PWX0		
		P55/ $\overline{IRQ13}$ /RxD2		
		P54/ $\overline{IRQ12}$ /TxD2		
		P53/ $\overline{IRQ11}$ /RxD1/IrRxD		
P52/ $\overline{IRQ10}$ /TxD1/IrTxD				
		P51/ $\overline{IRQ9}$ /RxD0		
		P50/ $\overline{IRQ8}$ /TxD0		

Table 8.1 Port Functions (cont)

Port	Description	Extended Mode (EXPE = 1)		Single-Chip Mode (EXPE = 0)	I/O Status
Port 6	General I/O port also functioning as bidirectional data bus, FRT input/output, keyboard input	P67/ $\overline{\text{KIN7}}^{*1}$	D7 ^{*2}	P67/ $\overline{\text{KIN7}}$	Built-in input pull- up MOSs
		P66/ $\overline{\text{FTOB/KIN6}}^{*1}$	D6 ^{*2}	P66/ $\overline{\text{FTOB/KIN6}}$	
		P65/ $\overline{\text{FTID/KIN5}}^{*1}$	D5 ^{*2}	P65/ $\overline{\text{FTID/KIN5}}$	
		P64/ $\overline{\text{FTIC/KIN4}}^{*1}$	D4 ^{*2}	P64/ $\overline{\text{FTIC/KIN4}}$	
		P63/ $\overline{\text{FTIB/KIN3}}^{*1}$	D3 ^{*2}	P63/ $\overline{\text{FTIB/KIN3}}$	
		P62/ $\overline{\text{FTIA/KIN2}}^{*1}$	D2 ^{*2}	P62/ $\overline{\text{FTIA/KIN2}}$	
		P61/ $\overline{\text{FTOA/KIN1}}^{*1}$	D1 ^{*2}	P61/ $\overline{\text{FTOA/KIN1}}$	
Port 7	General I/O port also functioning as A/D converter analog input, D/A converter analog output, and interrupt input	P77/ $\overline{\text{ExIRQ7/AN7/DA1}}$			
		P76/ $\overline{\text{ExIRQ6/AN6/DA0}}$			
		P75/ $\overline{\text{ExIRQ5/AN5}}$			
		P74/ $\overline{\text{ExIRQ4/AN4}}$			
		P73/ $\overline{\text{ExIRQ3/AN3}}$			
		P72/ $\overline{\text{ExIRQ2/AN2}}$			
		P71/ $\overline{\text{AN1}}$ P70/ $\overline{\text{AN0}}$			

Table 8.1 Port Functions (cont)

Port	Description	Extended Mode (EXPE = 1)	Single-Chip Mode (EXPE = 0)	I/O Status
Port 8	General I/O port also functioning as A/D converter external trigger input pin, SCI_0, SCI_1, and SCI_2 clock inputs/outputs, TMR_0, TMR_1, TMR_X, TMR_Y inputs, and IIC_0 and IIC_1 inputs/outputs	P87/ $\overline{\text{ExIRQ15}}$ /ADTRG/ExTMIY P86/ $\overline{\text{ExIRQ14}}$ /SCK2/ExTMIX P85/ $\overline{\text{ExIRQ13}}$ /SCK1/ExTMI1 P84/ $\overline{\text{ExIRQ12}}$ /SCK0/ExTMI0 P83/ $\overline{\text{ExIRQ11}}$ /SDA1 P82/ $\overline{\text{ExIRQ10}}$ /SCL1 P81/ $\overline{\text{ExIRQ9}}$ /SDA0 P80/ $\overline{\text{ExIRQ8}}$ /SCL0		NMOS push-pull outputs.
Port 9	General I/O port also functioning as bus control input/output, system clock output, and external sub-clock input	P97/ $\overline{\text{WAIT}}$ / $\overline{\text{CS256}}$ P96/ ϕ / $\overline{\text{EXCL}}$ $\overline{\text{AS}}$ / $\overline{\text{IOS3}}$ $\overline{\text{HWR}}$ $\overline{\text{RD}}$ P92/ $\overline{\text{CPCS1}}$ P91/ $\overline{\text{AH}}$ P90/ $\overline{\text{LWR}}$	P97 P95 P94 P93 P92 P91 P90	

Table 8.1 Port Functions (cont)

Port	Description	Extended Mode (EXPE = 1)	Single-Chip Mode (EXPE = 0)	I/O Status
Port A	General I/O port also functioning as DTC event counter input, address output, keyboard input, and SCI_0 and SCI_2 external control pins	PA7/KIN15/ A23/EVENT7	PA7/KIN15/ EVENT7	Built-in input pull-up MOSS
		PA6/KIN14/ A22/EVENT6	PA6/KIN14/ EVENT6	
		PA5/KIN13/ A21/EVENT5	PA5/KIN13/ EVENT5	
		PA4/KIN12/ A20/EVENT4	PA4/KIN12/ EVENT4	
		PA3/KIN11/ A19/EVENT3	PA3/KIN11/ EVENT3	
		PA2/KIN10/ A18/EVENT2	PA2/KIN10/ EVENT2	
		PA1/KIN9/ A17/SSE2/ EVENT1	PA1/KIN9/ SSE2/ EVENT1	
		PA0/KIN8/ A16/SSE0/ EVENT0	PA0/KIN8/ SSE0/ EVENT0	
Port B	General I/O port also functioning as DTC event counter input	PB7/EVENT15		
		PB6/EVENT14		
		PB5/EVENT13		
		PB4/EVENT12		
		PB3/EVENT11		
		PB2/EVENT10		
		PB1/EVENT9 PB0/EVENT8		
Port C	General I/O port also functioning as PWMX output and IIC_2, IIC_3, and IIC_4 I/O pins	PC7/PWX3		NMOS push-pull outputs (PC0 to PC5)
		PC6/PWX2		
		PC5/SDA4		
		PC4/SCL4		
		PC3/SDA3		
		PC2/SCL3		
		PC1/SDA2 PC0/SCL2		
Port D	General I/O port also functioning as LPC I/O, and IIC_5 I/O pins	PD7/SDA5		Built-in input pull-up MOSS (PD0 to PD5) NMOS push-pull outputs (PD6 to PD7)
		PD6/SCL5		
		PD5/LPCPD		
		PD4/CLKRUN		
		PD3/GA20		
		PD2/PME		
		PD1/LSMI PD0/LSCI		

Table 8.1 Port Functions (cont)

Port	Description	Extended Mode (EXPE = 1)	Single-Chip Mode (EXPE = 0)	I/O Status
Port E	General I/O port also functioning as LPC I/O	PE7/SERIRQ PE6/LCLK PE5/LRESET PE4/LFRAME PE3/LAD3 PE2/LAD2 PE1/LAD1 PE0/LAD0		
Port F	General I/O port also functioning as PWM output pin	PF2/ExPW2 PF1/ExPW1 PF0/ExPW0		

Notes: 1. 8-bit data bus is selected.
2. 16-bit data bus is selected.

8.1 Port 1

Port 1 is an 8-bit I/O port. Port 1 pins also function as an address bus, PWM output pins, and address/data multiplex bus. Port 1 functions change according to the operating mode. Port 1 has the following registers.

- Port 1 data direction register (P1DDR)
- Port 1 data register (P1DR)
- Port 1 pull-up MOS control register (P1PCR)

8.1.1 Port 1 Data Direction Register (P1DDR)

The individual bits of P1DDR specify input or output for the pins of port 1.

Bit	Bit Name	Initial Value	R/W	Description
7	P17DDR	0	W	In normal extended mode (ADMXE = 0):
6	P16DDR	0	W	The corresponding port 1 pins are address output
5	P15DDR	0	W	when P1DDR bits are set to 1, and input ports when
4	P14DDR	0	W	cleared to 0.
3	P13DDR	0	W	In address/data multiplex extended mode (ADMXE =
2	P12DDR	0	W	1):
1	P11DDR	0	W	When the bus width is 16 bits, lower 8 bits of
0	P10DDR	0	W	address/data multiplex bus. When the bus width is 8
				bits, this register is used in the same way as in single
				chip mode.
				In single-chip mode:
				The corresponding port 1 pins are output ports or
				PWM outputs when the P1DDR bits are set to 1, and
				input ports when cleared to 0.

8.1.2 Port 1 Data Register (P1DR)

P1DR stores output data for the port 1 pins.

Bit	Bit Name	Initial Value	R/W	Description
7	P17DR	0	R/W	P1DR stores output data for the port 1 pins that are used as the general output port.
6	P16DR	0	R/W	
5	P15DR	0	R/W	If a port 1 read is performed while the P1DDR bits are set to 1, the P1DR values are read. If a port 1 read is performed while the P1DDR bits are cleared to 0, the pin states are read.
4	P14DR	0	R/W	
3	P13DR	0	R/W	
2	P12DR	0	R/W	
1	P11DR	0	R/W	
0	P10DR	0	R/W	

8.1.3 Port 1 Pull-Up MOS Control Register (P1PCR)

P1PCR controls the port 1 built-in input pull-up MOSs.

Bit	Bit Name	Initial Value	R/W	Description
7	P17PCR	0	R/W	When the pins are in input state, the corresponding input pull-up MOS is turned on when a P1PCR bit is set to 1.
6	P16PCR	0	R/W	
5	P15PCR	0	R/W	In address-data multiplex extended bus mode is used, the initial value should not be changed.
4	P14PCR	0	R/W	
3	P13PCR	0	R/W	
2	P12PCR	0	R/W	
1	P11PCR	0	R/W	
0	P10PCR	0	R/W	

8.1.4 Pin Functions

The relationship between register setting values and pin functions are as follows in each operating mode.

Extended Mode (EXPE = 1):

The function of port 1 pins is switched as shown below according to the P1nDDR bit.

P1nDDR	0			1		
	0	1		0	1	
ADMXE	—	Either bit is 0 (8/16 bit bus)	All 1 (8 bit bus)	—	Either bit is 0	All 1 (8 bit bus)
ABW, ABW256, ABWCP	—	Either bit is 0 (8/16 bit bus)	All 1 (8 bit bus)	—	Either bit is 0	All 1 (8 bit bus)
Pin function	P1n input pin	AD7 to AD0 input/output pin	P1n input pin	A7 to A0 output pin	Setting prohibited	P1n output pin

[Legend]

n = 7 to 0

Single-Chip Mode (EXPE = 0):

The function of port 1 pins is switched as shown below according to the combination of the OEn bit and P1nDDR bit in PWOERA of PWM and the PWMS bit in PTCNT0.

P1nDDR	0	1	1	1
PWMS	—	0	1	0
OEn	—	0	—	1
Pin function	P1n input pin	P1n output pin		PWn output pin

[Legend]

n = 7 to 0

8.1.5 Port 1 Input Pull-Up MOS

Port 1 has a built-in input pull-up MOS that can be controlled by software. This input pull-up MOS can be used regardless of the operating mode. Table 8.2 summarizes the input pull-up MOS states.

Table 8.2 Port 1 Input Pull-Up MOS States

Reset	Hardware Standby Mode	Software Standby Mode	In Other Operations
Off	Off	On/Off	On/Off

[Legend]

Off: Always off.

On/Off: On when P1DDR = 0 and P1PCR = 1; otherwise off.

8.2 Port 2

Port 2 is an 8-bit I/O port. Port 2 pins also function as an address bus, PWM output pins, and address-data multiplex bus. Port 2 functions change according to the operating mode. Port 2 has the following registers.

- Port 2 data direction register (P2DDR)
- Port 2 data register (P2DR)
- Port 2 pull-up MOS control register (P2PCR)

8.2.1 Port 2 Data Direction Register (P2DDR)

The individual bits of P2DDR specify input or output for the pins of port 2.

Bit	Bit Name	Initial Value	R/W	Description
7	P27DDR	0	W	In normal extended mode (ADMXE = 0):
6	P26DDR	0	W	The corresponding port 2 pins are address output ports when the P2DDR bits are set to 1, and input ports when cleared to 0.
5	P25DDR	0	W	
4	P24DDR	0	W	Pins function as the address output port depending on the setting of bits IOSE and CS256E in SYSCR.
3	P23DDR	0	W	
2	P22DDR	0	W	Address/data multiplex extended mode (ADMXE = 1):
1	P21DDR	0	W	
0	P20DDR	0	W	The upper 8-bit of address/data multiplex bus. In single-chip mode: The corresponding port 2 pins are output ports or PWM outputs when the P2DDR bits are set to 1, and input ports when cleared to 0.

8.2.2 Port 2 Data Register (P2DR)

P2DR stores output data for the port 2 pins.

Bit	Bit Name	Initial Value	R/W	Description
7	P27DR	0	R/W	P2DR stores output data for the port 2 pins that are used as the general output port.
6	P26DR	0	R/W	
5	P25DR	0	R/W	If a port 2 read is performed while the P2DDR bits are set to 1, the P2DR values are read. If a port 2 read is performed while the P2DDR bits are cleared to 0, the pin states are read.
4	P24DR	0	R/W	
3	P23DR	0	R/W	
2	P22DR	0	R/W	
1	P21DR	0	R/W	
0	P20DR	0	R/W	

8.2.3 Port 2 Pull-Up MOS Control Register (P2PCR)

P2PCR controls the port 2 built-in input pull-up MOSs.

Bit	Bit Name	Initial Value	R/W	Description
7	P27PCR	0	R/W	When the pins are in input state, the corresponding input pull-up MOS is turned on when a P2PCR bit is set to 1.
6	P26PCR	0	R/W	
5	P25PCR	0	R/W	
4	P24PCR	0	R/W	
3	P23PCR	0	R/W	
2	P22PCR	0	R/W	
1	P21PCR	0	R/W	
0	P20PCR	0	R/W	

8.2.4 Pin Functions

The relationship between register setting values and pin functions are as follows in each operating mode.

Extended Mode (EXPE = 1):

The function of port 2 pins is switched as shown below according to the combination of the CS256E and IOSE bits in SYSCR, the ADFULLE and CPCSE bits in BCR2 of BSC, and the P2nDDR bit.

Addresses 13 and 11 in the following table are expressed by the following logical expressions:

$$\text{Address 13} = 1 : \overline{\text{ADFULLE}} \cdot \overline{\text{CS256E}} \cdot (\text{CPCSE} \mid \text{IOSE})$$

$$\text{Address 11} = 1 : \text{ADFULLE} \cdot \overline{\text{CS256E}} \cdot \overline{\text{CPCSE}} \cdot \text{IOSE}$$

P2nDDR	0		1		
ADMXE	0	1	0		1
Address 13	—	—	0	1	—
Pin function	P27 to P25 input pins	AD15 to AD13 input/output pins	A15 to A13 output pins	P27 to P25 output pins	AD15 to AD13 input/output pins

[Legend]

n = 7 to 5

P24DDR	0		1		
ADMXE	0	1	0		1
Address 11	—	—	0	1	—
Pin function	P24 input pin	AD12 input/output pin	A12 output pin	P24 output pin	AD12 input/output pin

P23DDR	0		1		
ADMXE	0	1	0		1
Address 11	—	—	0	1	—
Pin function	P23 input pin	AD11 input/output pin	A11 output pin	P23 output pin	AD11 input/output pin

P2nDDR	0		1	
ADMXE	0	1	0	1
Pin function	P2n input pins	AD10 to AD8 input/output pins	A10 to A8 output pins	AD10 to AD8 input/output pins

[Legend]

n = 7 to 0

Single-Chip Mode (EXPE = 0):

The function of port 2 pins is switched as shown below according to the combination of the OEM bit in PWOERB of PWR and the P2nDDR bit.

P2nDDR	0	1	
OEm	—	0	1
Pin function	P27 to P20 input pins	P27 to P20 output pins	PW15 to PW8 output pins

[Legend]

n = 7 to 0

m = 15 to 8

8.2.5 Port 2 Input Pull-Up MOS

Port 2 has a built-in input pull-up MOS that can be controlled by software. This input pull-up MOS can be used regardless of the operating mode. Table 8.3 summarizes the input pull-up MOS states.

Table 8.3 Port 2 Input Pull-Up MOS States

Reset	Hardware Standby Mode	Software Standby Mode	In Other Operations
Off	Off	On/Off	On/Off

[Legend]

Off: Always off.

On/Off: On when P2DDR = 0 and P2PCR = 1; otherwise off.

8.3 Port 3

Port 3 is an 8-bit I/O port. Port 3 pins also function as a bidirectional data bus, wake-up event input pins. Port 3 functions change according to the operating mode. Port 3 has the following registers.

- Port 3 data direction register (P3DDR)
- Port 3 data register (P3DR)
- Port 3 pull-up MOS control register (P3PCR)

8.3.1 Port 3 Data Direction Register (P3DDR)

The individual bits of P3DDR specify input or output for the pins of port 3.

Bit	Bit Name	Initial Value	R/W	Description
7	P37DDR	0	W	In normal extended mode:
6	P36DDR	0	W	Bidirectional data bus
5	P35DDR	0	W	In other mode:
4	P34DDR	0	W	The corresponding port 3 pins are output ports when the P3DDR bits are set to 1, and input ports when cleared to 0.
3	P33DDR	0	W	
2	P32DDR	0	W	
1	P31DDR	0	W	
0	P30DDR	0	W	

8.3.2 Port 3 Data Register (P3DR)

P3DR stores output data for the port 3 pins.

Bit	Bit Name	Initial Value	R/W	Description
7	P37DR	0	R/W	In normal extended mode (ADMXE = 0):
6	P36DR	0	R/W	If a port 3 read is performed while the P3DDR bits are set to 1, the P3DR values are read. When the P3DDR bits are cleared to 0, 1 is read.
5	P35DR	0	R/W	
4	P34DR	0	R/W	In other mode:
3	P33DR	0	R/W	If a port 3 read is performed while the P3DDR bits are set to 1, the P3DR values are read. If a port 3 read is performed while the P3DDR bits are cleared to 0, the pin states are read.
2	P32DR	0	R/W	
1	P31DR	0	R/W	
0	P30DR	0	R/W	

8.3.3 Port 3 Pull-Up MOS Control Register (P3PCR)

P3PCR controls the port 3 built-in input pull-up MOSs.

Bit	Bit Name	Initial Value	R/W	Description
7	P37PCR	0	R/W	In normal extended mode:
6	P36PCR	0	R/W	Operation is not affected.
5	P35PCR	0	R/W	In other mode:
4	P34PCR	0	R/W	When the pins are in input state, the corresponding
3	P33PCR	0	R/W	input pull-up MOS is turned on when a P3PCR bit is set to 1.
2	P32PCR	0	R/W	
1	P31PCR	0	R/W	
0	P30PCR	0	R/W	

8.3.4 Pin Functions

Normal Extended Mode:

Port 3 pins automatically function as the bidirectional data bus.

Address/Data Multiplex Mode:

Same operation as the single-chip mode.

Single-Chip Mode:

- P37/ $\overline{WUE15}$

The pin function is switched as shown below according to the P37DDR bit.

When the WUEM15 bit in WUEMR3 of the interrupt controller is cleared to 0, this pin can be used as the $\overline{WUE15}$ input pin. To use this pin as the $\overline{WUE15}$ input pin, clear the P37DDR bit to 0.

P37DDR	0		1
WUEM15	0	1	—
Pin Function	$\overline{WUE15}$ input pin	P37 input pin	P37 output pin

- P36/ $\overline{\text{WUE14}}$

The pin function is switched as shown below according to the P36DDR bit.

When the WUEM14 bit in WUEMR3 of the interrupt controller is cleared to 0, this pin can be used as the $\overline{\text{WUE14}}$ input pin. To use this pin as the $\overline{\text{WUE14}}$ input pin, clear the P36DDR bit to 0.

P36DDR	0		1
WUEM14	0	1	—
Pin function	$\overline{\text{WUE14}}$ input pin	P36 input pin	P36 output pin

- P35/ $\overline{\text{WUE13}}$

The pin function is switched as shown below according to the P35DDR bit.

When the WUEM13 bit in WUEMR3 of the interrupt controller is cleared to 0, this pin can be used as the $\overline{\text{WUE13}}$ input pin. To use this pin as the $\overline{\text{WUE13}}$ input pin, clear the P35DDR bit to 0.

P35DDR	0		1
WUEM13	0	1	—
Pin function	$\overline{\text{WUE13}}$ input pin	P35 input pin	P35 output pin

- P34/ $\overline{\text{WUE12}}$

The pin function is switched as shown below according to the P34DDR bits.

When the WUEM12 bit in WUEMR3 of the interrupt controller is cleared to 0, this pin can be used as the $\overline{\text{WUE12}}$ input pin. To use this pin as the $\overline{\text{WUE12}}$ input pin, clear the P34DDR bit to 0.

P34DDR	0		1
WUEM12	0	1	—
Pin function	$\overline{\text{WUE12}}$ input pin	P34 input pin	P34 output pin

- P33/ $\overline{\text{WUE11}}$

The pin function is switched as shown below according to the P33DDR bits.

When the WUEM11 bit in WUEMR3 of the interrupt controller is cleared to 0, this pin can be used as the $\overline{\text{WUE11}}$ input pin. To use this pin as the $\overline{\text{WUE11}}$ input pin, clear the P33DDR bit to 0.

P33DDR	0		1
WUEM11	0	1	—
Pin function	$\overline{\text{WUE11}}$ input pin	P33 input pin	P33 output pin

- P32/ $\overline{\text{WUE10}}$

The pin function is switched as shown below according to the P32DDR bits.

When the WUEM10 bit in WUEMR3 of the interrupt controller is cleared to 0, this pin can be used as the $\overline{\text{WUE10}}$ input pin. To use this pin as the $\overline{\text{WUE10}}$ input pin, clear the P32DDR bit to 0.

P32DDR	0		1
WUEM10	0	1	—
Pin function	$\overline{\text{WUE10}}$ input pin	P32 input pin	P32 output pin

- P31/ $\overline{\text{WUE9}}$

The pin function is switched as shown below according to the P31DDR bits.

When the WUEM9 bit in WUEMR3 of the interrupt controller is cleared to 0, this pin can be used as the $\overline{\text{WUE9}}$ input pin. To use this pin as the $\overline{\text{WUE9}}$ input pin, clear the P31DDR bit to 0.

P31DDR	0		1
WUEM9	0	1	—
Pin function	$\overline{\text{WUE9}}$ input pin	P31 input pin	P31 output pin

- P30/ $\overline{\text{WUE8}}$

The pin function is switched as shown below according to the P30DDR bits.

When the WUEM8 bit in WUEMR3 of the interrupt controller is cleared to 0, this pin can be used as the $\overline{\text{WUE8}}$ input pin. To use this pin as the $\overline{\text{WUE8}}$ input pin, clear the P30DDR bit to 0.

P30DDR	0		1
WUEM8	0	1	—
Pin function	$\overline{\text{WUE8}}$ input pin	P30 input pin	P30 output pin

8.3.5 Port 3 Input Pull-Up MOS

Port 3 has a built-in input pull-up MOS that can be controlled by software. This input pull-up MOS can be used in single-chip mode. Table 8.4 summarizes the input pull-up MOS states.

Table 8.4 Port 3 Input Pull-Up MOS States

Mode	Reset	Hardware Standby Mode	Software Standby Mode	In Other Operations
Normal extended mode (EXPE = 1, ADMXE = 0)	Off	Off	Off	Off
Single-chip mode (EXPE = 0)	Off	Off	On/Off	On/Off
Address-data multiplex extended mode (EXPE = 1, ADMXE = 1)				

[Legend]

Off : Always off.

On/Off : On when input state and P3PCR = 1; otherwise off.

8.4 Port 4

Port 4 is an 8-bit I/O port. Port 4 pins also function as external interrupt input, and TMR_0, TMR_1, TMR_X, and TMR_Y input/output pins. Port 4 has the following registers.

- Port 4 data direction register (P4DDR)
- Port 4 data register (P4DR)

8.4.1 Port 4 Data Direction Register (P4DDR)

The individual bits of P4DDR specify input or output for the pins of port 4.

Bit	Bit Name	Initial Value	R/W	Description
7	P47DDR	0	W	If port 4 pins are specified for use as the general I/O port, the corresponding port 4 pins are output ports when the P4DDR bits are set to 1, and input ports when cleared to 0.
6	P46DDR	0	W	
5	P45DDR	0	W	
4	P44DDR	0	W	
3	P43DDR	0	W	
2	P42DDR	0	W	
1	P41DDR	0	W	
0	P40DDR	0	W	

8.4.2 Port 4 Data Register (P4DR)

P4DR stores output data for the port 4 pins.

Bit	Bit Name	Initial Value	R/W	Description
7	P47DR	0	R/W	P4DR stores output data for the port 4 pins that are used as the general output port.
6	P46DR	0	R/W	
5	P45DR	0	R/W	If a port 4 read is performed while the P4DDR bits are set to 1, the P4DR values are read. If a port 4 read is performed while the P4DDR bits are cleared to 0, the pin states are read.
4	P44DR	0	R/W	
3	P43DR	0	R/W	
2	P42DR	0	R/W	
1	P41DR	0	R/W	
0	P40DR	0	R/W	

8.4.3 Pin Functions

The relationship between register setting values and pin functions are as follows.

- P47/ $\overline{\text{IRQ7}}$ /TMOY

The pin function is switched as shown below according to the combination of the OS3 to OS0 bits in TCSR of TMR_Y and the P47DDR bit.

When the ISS7 bit in ISSR is cleared to 0 and the IRQ7E bit in IER of the interrupt controller is set to 1, this pin can be used as the $\overline{\text{IRQ7}}$ input pin. To use this pin as the $\overline{\text{IRQ7}}$ input pin, clear the P47DDR bit to 0.

OS3 to OS0	All 0		One bit is set as 1
P47DDR	0	1	—
Pin function	P47 input pin	P47 output pin	TMOY output pin
	$\overline{\text{IRQ7}}$ input pin		

- P46/ $\overline{\text{IRQ6}}$ /TMOX

The pin function is switched as shown below according to the combination of the OS3 to OS0 bits in TCSR of TMR_X and the P46DDR bit.

When the ISS6 bit in ISSR is cleared to 0 and the IRQ6E bit in IER of the interrupt controller is set to 1, this pin can be used as the $\overline{\text{IRQ6}}$ input pin. To use this pin as the $\overline{\text{IRQ6}}$ input pin, clear the P46DDR bit to 0.

OS3 to OS0	All 0		One bit is set as 1
P46DDR	0	1	—
Pin function	P46 input pin	P46 output pin	TMOX output pin
	$\overline{\text{IRQ6}}$ input pin		

- P45/ $\overline{\text{IRQ5}}$ /TMIY

The pin function is switched as shown below according to the P45DDR bit.

When the TMIYS bit in PTCNT0 is cleared to 0 and the external clock is selected by the CKS2 to CKS0 bits in TCR of TMR_Y, this bit is used as the TMCiY input pin. When the CCLR1 and CCLR0 bits in TCR of TMR_Y are set to 1, this pin is used as the TMRIY input pin.

When the ISS5 bit in ISSR is cleared to 0 and the IRQ5E bit in IER of the interrupt controller is set to 1, this pin can be used as the $\overline{\text{IRQ5}}$ input pin. To use this pin as the $\overline{\text{IRQ5}}$ input pin, clear the P45DDR bit to 0.

P45DDR	0	1
Pin function	P45 input pin	P45 output pin
	TMIY (TMCiY/TMRIY) input pin	
	$\overline{\text{IRQ5}}$ input pin	

- P44/ $\overline{\text{IRQ4}}$ /TMIX

The pin function is switched as shown below according to the P44DDR bits.

When the TMIXS bit in PTCNT0 is cleared to 0 and the external clock is selected by the CKS2 to CKS0 bits in TCR of TMR_X, this bit is used as the TMCiX input pin. When the CCLR1 and CCLR0 bits in TCR of TMR_X are set to 1, this pin is used as the TMRIY input pin.

When the ISS4 bit in ISSR is cleared to 0 and the IRQ4E bit in IER of the interrupt controller is set to 1, this pin can be used as the $\overline{\text{IRQ4}}$ input pin. To use this pin as the $\overline{\text{IRQ4}}$ input pin, clear the P44DDR bit to 0.

P44DDR	0	1
Pin function	P44 input pin	P44 output pin
	TMIY (TMCiY/TMRIY) input pin	
	$\overline{\text{IRQ4}}$ input pin	

- P43/ $\overline{\text{IRQ3}}$ /TMO1

The pin function is switched as shown below according to the OS3 to OS0 bits in TCSR of TMR_1 and the P43DDR bit. When the ISS3 bit in ISSR is cleared to 0 and the IRQ3E bit in IER of the interrupt controller is set to 1, this pin can be used as the $\overline{\text{IRQ3}}$ input pin. To use this pin as the $\overline{\text{IRQ3}}$ input pin, clear the P43DDR bit to 0.

OS3 to OS0	All 0		One bit is set as 1
P43DDR	0	1	—
Pin function	P43 input pin	P43 output pin	TMO1 output pin
	$\overline{\text{IRQ3}}$ input pin		

- P42/ $\overline{\text{IRQ2}}$ /TMO0

The pin function is switched as shown below according to the OS3 to OS0 bits in TCSR of TMR_0 and the P42DDR bit.

When the ISS2 bit in ISSR is cleared to 0 and the IRQ2E bit in IER of the interrupt controller is set to 1, this pin can be used as the $\overline{\text{IRQ2}}$ input pin. To use this pin as the $\overline{\text{IRQ2}}$ input pin, clear the P42DDR bit to 0.

OS3 to OS0	All 0		One bit is set as 1
P42DDR	0	1	—
Pin function	P42 input pin	P42 output pin	TMO0 output pin
	$\overline{\text{IRQ2}}$ input pin		

- P41/ $\overline{\text{IRQ1}}$ /TMI1

The pin function is switched as shown below according to the P41DDR bits.

When the TMI1S bit in PTCNT0 is cleared to 0 and the external clock is selected by the CKS2 to CKS0 bits in TCR of TMR_1, this bit is used as the TMC11 input pin. When the CCLR1 and CCLR0 bits in TCR of TMR_1 are set to 1, this pin is used as the TMRI1 input pin. When the ISS1 bit in ISSR is cleared to 0 and the IRQ1E bit in IER of the interrupt controller is set to 1, this pin can be used as the $\overline{\text{IRQ1}}$ input pin. To use this pin as the $\overline{\text{IRQ1}}$ input pin, clear the P41DDR bit to 0.

P41DDR	0	1
Pin function	P41 input pin	P41 output pin
	TMI1(TMC11/TMRI1) input pin	
	$\overline{\text{IRQ1}}$ input pins	

- P40/ $\overline{\text{IRQ0}}$ /TMI0

The pin function is switched as shown below according to the P40DDR bits.

When the TMI0S bit in PTCNT0 is cleared to 0 and the external clock is selected by the CKS2 to CKS0 bits in TCR of TMR_0, this bit is used as the TMC10 input pin. When the CCLR1 and CCLR0 bits in TCR of TMR_0 are set to 1, this pin is used as the TMRI0 input pin. When the ISS0 bit in ISSR is cleared to 0 and the IRQ0E bit in IER of the interrupt controller is set to 1, this pin can be used as the $\overline{\text{IRQ0}}$ input pin. To use this pin as the $\overline{\text{IRQ0}}$ input pin, clear the P40DDR bit to 0.

P40DDR	0	1
Pin function	P40 input pin	P40 output pin
	TMI0(TMC10/TMRI0) input pin	
	$\overline{\text{IRQ0}}$ input pin	

8.5 Port 5

Port 5 is an 8-bit I/O port. Port 5 pins also function as interrupt input pins, the PWMX output pin, SCI_0, SCI_1, and SCI_2 input/output pins. Port 5 has the following registers.

- Port 5 data direction register (P5DDR)
- Port 5 data register (P5DR)

8.5.1 Port 5 Data Direction Register (P5DDR)

The individual bits of P5DDR specify input or output for the pins of port 5.

Bit	Bit Name	Initial Value	R/W	Description
7	P57DDR	0	W	If port 5 pins are specified for use as the general I/O port, the corresponding port 5 pins are output ports when the P5DDR bits are set to 1, and input ports when cleared to 0.
6	P56DDR	0	W	
5	P55DDR	0	W	
4	P54DDR	0	W	
3	P53DDR	0	W	
2	P52DDR	0	W	
1	P51DDR	0	W	
0	P50DDR	0	W	

8.5.2 Port 5 Data Register (P5DR)

P5DR stores output data for the port 5 pins.

Bit	Bit Name	Initial Value	R/W	Description
7	P57DR	0	R/W	P5DR stores output data for the port 5 pins that are used as the general output port.
6	P56DR	0	R/W	
5	P55DR	0	R/W	If a port 5 read is performed while the P5DDR bits are set to 1, the P5DR values are read. If a port 5 read is performed while the P5DDR bits are cleared to 0, the pin states are read.
4	P54DR	0	R/W	
3	P53DR	0	R/W	
2	P52DR	0	R/W	
1	P51DR	0	R/W	
0	P50DR	0	R/W	

8.5.3 Pin Functions

The relationship between register setting values and pin functions are as follows.

- P57/ $\overline{\text{IRQ15}}$ /PWX1

The pin function is switched as shown below according to the combination of the OEB bit in DACR of PWMX and the P57DDR bit.

When the ISS15 bit in ISSR16 is cleared to 0 and the IRQ15E bit in IER16 of the interrupt controller is set to 1, this pin can be used as the $\overline{\text{IRQ15}}$ input pin. To use this pin as the $\overline{\text{IRQ15}}$ input pin, clear the P57DDR bit to 0.

OEB	0		1
P57DDR	0	1	—
Pin function	P57 input pin	P57 output pin	PWX1 output pin
	$\overline{\text{IRQ15}}$ input pin		

- P56/ $\overline{\text{IRQ14}}$ /PWX0

The pin function is switched as shown below according to the combination of the OEA bit in DACR of PWMX and the P56DDR bit.

When the ISS14 bit in ISSR16 is cleared to 0 and the IRQ14E bit in IER16 of the interrupt controller is set to 1, this pin can be used as the $\overline{\text{IRQ14}}$ input pin. To use this pin as the $\overline{\text{IRQ14}}$ input pin, clear the P56DDR bit to 0.

OEA	0		1
P56DDR	0	1	—
Pin function	P56 input pin	P56 output pin	PWX0 output pin
	$\overline{\text{IRQ14}}$ input pin		

- P55/ $\overline{\text{IRQ13}}$ /RxD2

The pin function is switched as shown below according to the combination of the RE bit in SCR of SCI_2 and the P55DDR bit.

When the ISS13 bit in ISSR16 is cleared to 0 and the IRQ13E bit in IER16 of the interrupt controller is set to 1, this pin can be used as the $\overline{\text{IRQ13}}$ input pin. To use this pin as the $\overline{\text{IRQ13}}$ input pin, clear the P55DDR bit to 0.

RE	0		1
P55DDR	0	1	—
Pin function	P55 input pin	P55 output pin	RxD2 input pin
	$\overline{\text{IRQ13}}$ input pin		

- P54/ $\overline{\text{IRQ12}}$ /TxD2

The pin function is switched as shown below according to the combination of the TE bit in SCR of SCI_2 and the P54DDR bit.

When the ISS12 bit in ISSR16 is cleared to 0 and the IRQ12E bit in IER16 of the interrupt controller is set to 1 this pin can be used as the $\overline{\text{IRQ12}}$ input pin. To use this pin as the $\overline{\text{IRQ12}}$ input pin, clear the P54DDR bit to 0.

TE	0		1
P54DDR	0	1	—
Pin function	P54 input pin	P54 output pin	TxD2 output pin
	$\overline{\text{IRQ12}}$ input pin		

- P53/ $\overline{\text{IRQ11}}$ /Rx/D1/Ir/RxD

The pin function is switched as shown below according to the combination of the RE bit in SCR of SCI_1 and the P53DDR bit.

When the ISS11 bit in ISSR16 is cleared to 0 and the IRQ11E bit in IER16 of the interrupt controller is set to 1, this pin can be used as the $\overline{\text{IRQ11}}$ input pin. To use this pin as the $\overline{\text{IRQ11}}$ input pin, clear the P53DDR bit to 0.

RE	0		1
P53DDR	0	1	—
Pin function	P53 input pin	P53 output pin	Rx/D1/Ir/RxD input pin
	$\overline{\text{IRQ11}}$ input pin		

- P52/ $\overline{\text{IRQ10}}$ /Tx/D1/Ir/TxD

The pin function is switched as shown below according to the combination of the TE bit in SCR of SCI_1 and the P52DDR bit.

When the ISS10 bit in ISSR16 is cleared to 0 and the IRQ10E bit in IER16 of the interrupt controller is set to 1, this pin can be used as the $\overline{\text{IRQ10}}$ input pin. To use this pin as the $\overline{\text{IRQ10}}$ input pin, clear the P52DDR bit to 0.

TE	0		1
P52DDR	0	1	—
Pin function	P52 input pin	P52 output pin	Tx/D1/Ir/TxD output pin
	$\overline{\text{IRQ10}}$ input pin		

- P51/ $\overline{\text{IRQ9}}$ /RxD0

The pin function is switched as shown below according to the combination of the RE bit in SCR of SCI_0 and the P51DDR bit.

When the ISS9 bit in ISSR16 is cleared to 0 and the IRQ9E bit in IER16 of the interrupt controller is set to 1, this pin can be used as the $\overline{\text{IRQ9}}$ input pin. To use this pin as the $\overline{\text{IRQ9}}$ input pin, clear the P51DDR bit to 0.

RE	0		1
P51DDR	0	1	—
Pin function	P51 input pin	P51 output pin	RxD0 input pin
	$\overline{\text{IRQ9}}$ input pin		

- P50/ $\overline{\text{IRQ8}}$ /TxD0

The pin function is switched as shown below according to the combination of the TE bit in SCR of SCI_0 and the P50DDR bit.

When the ISS8 bit in ISSR16 is cleared to 0 and the IRQ8E bit in IER16 of the interrupt controller is set to 1, this pin can be used as the $\overline{\text{IRQ8}}$ input pin. To use this pin as the $\overline{\text{IRQ8}}$ input pin, clear the P50DDR bit to 0.

TE	0		1
P50DDR	0	1	—
Pin function	P50 input pin	P50 output pin	TxD0 output pin
	$\overline{\text{IRQ8}}$ input pin		

8.6 Port 6

Port 6 is an 8-bit I/O port. Port 6 pins also function as the FRT input/output pin, keyboard input pin, and noise cancel input pin. Port 6 functions change according to the operating mode. The port can be used as the extended data bus (lower eight bits). Port 6 has the following registers.

- Port 6 data direction register (P6DDR)
- Port 6 data register (P6DR)
- Port 6 pull-up MOS control register (KMPCR6)
- System control register 2 (SYSCR2)
- Noise canceler enable register (P6NCE)
- Noise canceler decision control register (P6NCCMC)
- Noise cancel cycle setting register (P6NCCS)

8.6.1 Port 6 Data Direction Register (P6DDR)

The individual bits of P6DDR specify input or output for the pins of port 6.

Bit	Bit Name	Initial Value	R/W	Description
7	P67DDR	0	W	Normal extended mode (16-bit data bus):
6	P66DDR	0	W	The port functions as the data bus regardless of the values in these bits.
5	P65DDR	0	W	Other mode:
4	P64DDR	0	W	If port 6 pins are specified for use as the general I/O port, the corresponding port 6 pins are output ports when the P6DDR bits are set to 1, and input ports when cleared to 0.
3	P63DDR	0	W	
2	P62DDR	0	W	
1	P61DDR	0	W	
0	P60DDR	0	W	

8.6.2 Port 6 Data Register (P6DR)

P6DR stores output data for the port 6 pins.

Bit	Bit Name	Initial Value	R/W	Description
7	P67DR	0	R/W	Normal extended mode (16-bit data bus):
6	P66DR	0	R/W	If a port 6 read is performed while the P6DDR bits are set to 1, the P6DR values are read. If a port 6 read is performed while the P6DDR bits are cleared to 0, 1 is read.
5	P65DR	0	R/W	
4	P64DR	0	R/W	Other mode:
3	P63DR	0	R/W	
2	P62DR	0	R/W	P6DR stores output data for the port 6 pins that are used as the general output port.
1	P61DR	0	R/W	If a port 6 read is performed while the P6DDR bits are set to 1, the P6DR values are read. If a port 6 read is performed while the P6DDR bits are cleared to 0, the pin states are read.
0	P60DR	0	R/W	

8.6.3 Port 6 Pull-Up MOS Control Register (KMPCR6)

KMPCR6 controls the port 6 built-in input pull-up MOSs. This register is accessible when SYSCR KINWUE is 1. See section 3.2.2, System Control Register (SYSCR).

Bit	Bit Name	Initial Value	R/W	Description
7	KM7PCR	0	R/W	Normal extended mode (16-bit data bus):
6	KM6PCR	0	R/W	Operation is not affected.
5	KM5PCR	0	R/W	Other mode:
4	KM4PCR	0	R/W	When the pins are in input state, the corresponding input pull-up MOS is turned on when a KMPCR6 bit is set to 1.
3	KM3PCR	0	R/W	
2	KM2PCR	0	R/W	
1	KM1PCR	0	R/W	
0	KM0PCR	0	R/W	

8.6.4 System Control Register 2 (SYSCR2)

SYSCR2 controls the current specifications for the port 6 input pull-up MOSs and address data multiplex operation.

Bit	Bit Name	Initial Value	R/W	Description
7, 6	—	All 0	R/W	Reserved The initial value should not be changed.
5	P6PUE	0	R/W	Port 6 Input Pull-Up Extra Selects the current specification for the input pull-up MOS connected by means of KMPCR settings. 0: Standard current specification is selected 1: Current-limit specification is selected
4	—	0	R/W	Reserved The initial value should not be changed.
3	ADMXE	0	R/W	Address data multiplex bus interface enable 0: Normal extended bus interface 1: Address data multiplex extended bus interface
2 to 0	—	All 0	R/W	Reserved The initial value should not be changed.

8.6.5 Noise Canceler Enable Register (P6NCE)

P6NCE enables or disables the noise canceler circuit at port 6.

Bit	Bit Name	Initial Value	R/W	Description
7	P67NCE	0	R/W	In 16 bit bus mode in extended mode:
6	P66NCE	0	R/W	Port 6 operates as the data pin (D7 to D0).
5	P65NCE	0	R/W	In other mode:
4	P64NCE	0	R/W	Noise canceler circuit is enabled and the pin state is fetched in the P6DR in the sampling cycle set by the P6NCCS.
3	P63NCE	0	R/W	
2	P62NCE	0	R/W	The operating state changes according to the other control bits. Check the pin functions.
1	P61NCE	0	R/W	
0	P60NCE	0	R/W	

8.6.6 Noise Canceler Mode Control Register (P6NCCM)

P6NCCM controls whether 1 or 0 is expected for the input signal to port 6 in bit units.

Bit	Bit Name	Initial Value	R/W	Description
7	P67NCCM	1	R/W	In 16 bit bus mode in extended mode:
6	P66NCCM	1	R/W	Port 6 operates as the data pin (D7 to D0).
5	P65NCCM	1	R/W	In other mode:
4	P64NCCM	1	R/W	1 expected: 1 is stored in the port data register while 1 is input stably
3	P63NCCM	1	R/W	0 expected: 0 is stored in the port data register while 0 is input stably
2	P62NCCM	1	R/W	
1	P61NCCM	1	R/W	
0	P60NCCM	1	R/W	

8.6.7 Noise Canceler Cycle Setting Register (P6NCCS)

P6NCCS controls the sampling cycles of the noise canceler.

Bit	Bit Name	Initial Value	R/W	Description
7 to 3	—	All undefined	R/W	Reserved. The read data is undefined. The initial value should not be changed.
2	NCCK2	0	R/W	These bits set the sampling cycles of the noise canceler.
1	NCCK1	0	R/W	
0	NCCK0	0	R/W	000: 0.06 μ s $\phi/2$ 001: 0.97 μ s $\phi/32$ 010: 15.5 μ s $\phi/512$ 011: 248.2 μ s $\phi/8192$ 100: 993.0 μ s $\phi/32768$ 101: 2.0 ms $\phi/65536$ 110: 4.0 ms $\phi/131072$ 111: 7.9 ms $\phi/262144$

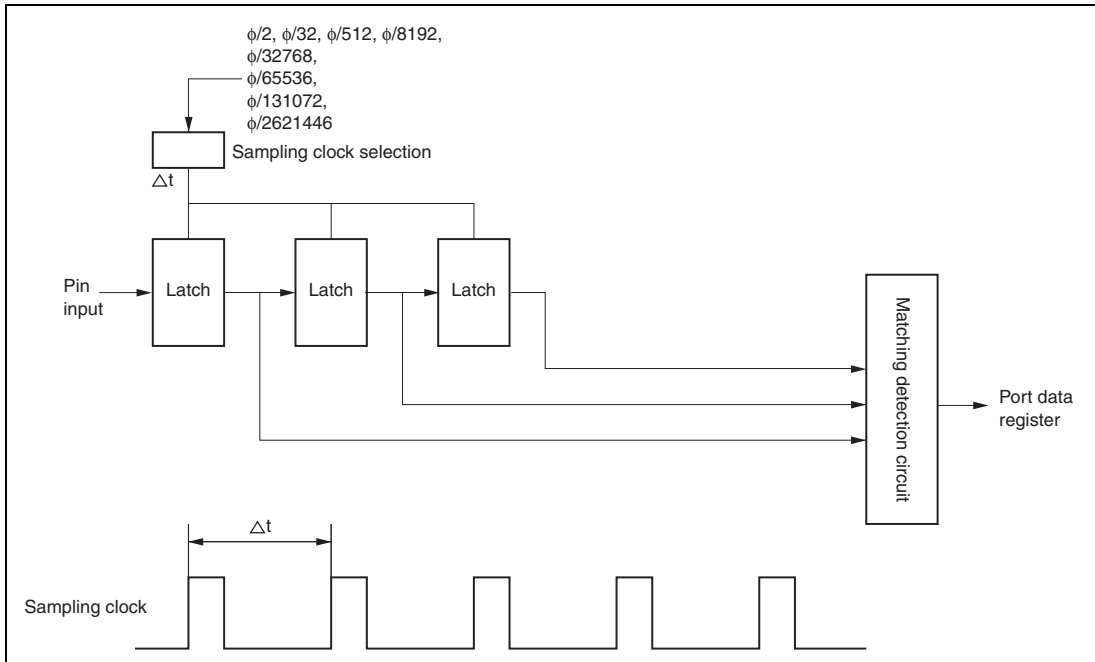

Figure 8.1 Noise Canceler Circuit

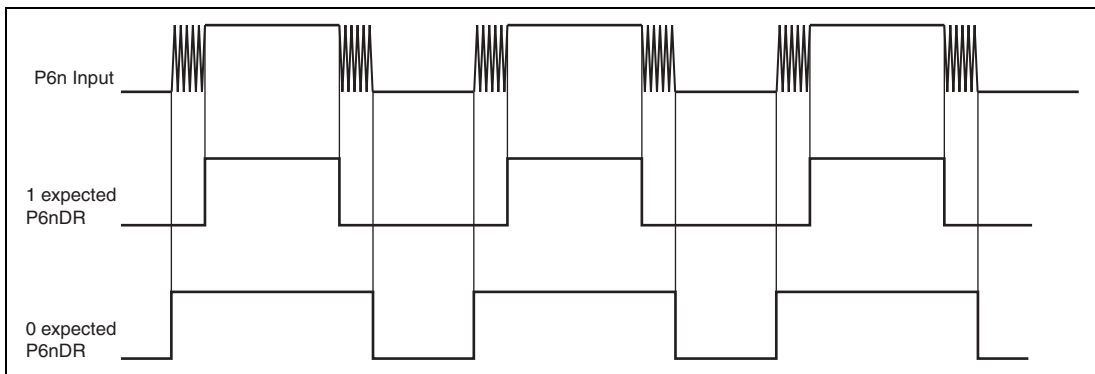

Figure 8.2 Noise Canceler Operation

8.6.8 Pin Functions

Normal Extended Mode: Port 6 automatically become the bidirectional data bus in 16-bit bus mode. The port 6 pins function the same as in shingle chip mode in 8-bit bus mode.

Address-Data Multiplex Extended Mode: The port 6 pins function the same as in shingle chip mode.

Single Chip Mode: The relationship between the register setting values and pin functions are as follows.

Port 6 pins also function as the FRT input/output pin, keyboard input pin, noise cancel input pin, or I/O port.

- P67/ $\overline{\text{KIN7}}$

The function of port 6 pins is switched as shown below according to the P67DDR bit.

When the KMIM7 bit in KMIMR6 of the interrupt controller is cleared to 0, this pin can be used as the $\overline{\text{KIN7}}$ input pin. To use this pin as the $\overline{\text{KIN7}}$ input pin, clear the P67DDR bit to 0.

Mode	Port		
P67DDR	0	0	1
P67NCE	0	1	—
Pin function	P67 input pin	P67 input pin (noise canceling)	P67 output pin
	$\overline{\text{KIN7}}$ input pin		

- P66/FTOB/ $\overline{\text{KIN6}}$

The function of port 6 pins is switched as shown below according to the combination of the OEB bit in TOCR of FRT and the P66DDR bit.

When the KMIM6 bit in KMIMR6 of the interrupt controller is cleared to 0, this pin can be used as the $\overline{\text{KIN6}}$ input pin. To use this pin as the $\overline{\text{KIN6}}$ input pin, clear the P66DDR bit to 0.

Mode	Port			FRT
OEB	0	0	0	1
P66DDR	0	0	1	—
P66NCE	0	1	—	—
Pin function	P66 input pin	P66 input pin (noise canceling)	P66 output pin	FTOB output pin
	$\overline{\text{KIN6}}$ input pin			

- P65/FTID/ $\overline{\text{KIN5}}$

The function of port 6 pins is switched as shown below according to the P65DDR bit.

When the ICIDE bit in TIER of FRT is set to 1, this pin can be used as the FTID input pin.

When the KMIM5 bit in KMIMR6 of the interrupt controller is cleared to 0, this pin can be used as the $\overline{\text{KIN5}}$ input pin. To use this pin as the $\overline{\text{KIN5}}$ input pin, clear the P65DDR bit to 0.

Mode	Port			FRT
P65DDR	0	0	1	0
P65NCE	0	1	—	0
Pin function	P65 input pin	P65 input pin (noise canceling)	P65 output pin	FTID input pin
	$\overline{\text{KIN5}}$ input pin			

- P64/FTIC/ $\overline{\text{KIN4}}$

The function of port 6 pins is switched as shown below according to the P64DDR bit.

When the ICICE bit in TIER of FRT is set to 1, this pin can be used as the FTIC input pin.

When the KMIM4 bit in KMIMR6 of the interrupt controller is cleared to 0, this pin can be used as the $\overline{\text{KIN4}}$ input pin. To use this pin as the $\overline{\text{KIN4}}$ input pin, clear the P64DDR bit to 0.

Mode	Port			FRT
P64DDR	0	0	1	0
P64NCE	0	1	—	0
Pin function	P64 input pin	P64 input pin (noise canceling)	P64 output pin	FTIC input pin
	$\overline{\text{KIN4}}$ input pin			

- P63/FTIB/ $\overline{\text{KIN3}}$

The function of port 6 pins is switched as shown below according to the P63DDR bit.

When the ICIBE bit in TIER of FRT is set to 1, this pin can be used as the FTIB input pin.

When the KMIM3 bit in KMIMR6 of the interrupt controller is cleared to 0, this pin can be used as the $\overline{\text{KIN3}}$ input pin. To use this pin as the $\overline{\text{KIN3}}$ input pin, clear the P63DDR bit to 0.

Mode	Port			FRT
P63DDR	0	0	1	0
P63NCE	0	1	—	0
Pin function	P63 input pin	P63 input pin (noise canceling)	P63 output pin	FTIB input pin
	$\overline{\text{KIN3}}$ input pin			

- P62/FTIA/ $\overline{\text{KIN2}}$

The function of port 6 pins is switched as shown below according to the P62DDR bit.

When the ICIAE bit in TIER of FRT is set to 1, this pin can be used as the FTIA input pin.

When the KMIM2 bit in KMIMR6 of the interrupt controller is cleared to 0, this pin can be used as the $\overline{\text{KIN2}}$ input pin. To use this pin as the $\overline{\text{KIN2}}$ input pin, clear the P62DDR bit to 0.

Mode	Port			FRT
P62DDR	0	0	1	0
P62NCE	0	1	—	0
Pin function	P62 input pin	P62 input pin (noise canceling)	P62 output pin	FTIA input pin
	$\overline{\text{KIN2}}$ input pin			

- P61/FTOA/ $\overline{\text{KIN1}}$

The function of port 6 pins is switched as shown below according to the combination of the OEA bit in TOCR of FRT, and the P61DDR bit.

When the KMIM1 bit in KMIMR6 of the interrupt controller is cleared to 0, this pin can be used as the $\overline{\text{KIN1}}$ input pin. To use this pin as the $\overline{\text{KIN1}}$ input pin, clear the P61DDR bit to 0.

Mode	Port			FRT
OEA	0	0	0	1
P61DDR	0	0	1	—
P61NCE	0	1	—	—
Pin function	P61 input pin	P61 input pin (noise canceling)	P61 output pin	FTOA output pin
	$\overline{\text{KIN1}}$ input pin			

- P60/FTCI/ $\overline{\text{KIN0}}$

The function of port 6 pins is switched as shown below according to the P60DDR bit.

When the CKS1 and CKS0 bits in TCR of FRT are both set to 1, this pin can be used as the FTCl input pin. When the $\overline{\text{KMIM0}}$ bit in KMIMR6 of the interrupt controller is cleared to 0, this pin can be used as the $\overline{\text{KIN0}}$ input pin. To use this pin as the $\overline{\text{KIN0}}$ input pin, clear the P60DDR bit to 0.

Mode	Port			FRT
P60DDR	0	0	1	0
P60NCE	0	1	—	0
Pin function	P60 input pin	P60 input pin (noise canceling)	P60 output pin	FTCl input pin
	$\overline{\text{KIN0}}$ input pin			

8.6.9 Port 6 Input Pull-Up MOS

Port 6 has a built-in input pull-up MOS that can be controlled by software. This input pull-up MOS can be used regardless of the operating mode. Table 8.5 summarizes the input pull-up MOS states.

Table 8.5 Port 6 Input Pull-Up MOS States

Reset	Hardware Standby Mode	Software Standby Mode	In Other Operations
Off	Off	On/Off	On/Off

[Legend]

Off : Always off.

On/Off : On when input state and KMPCR = 1; otherwise off.

8.7 Port 7

Port 7 is an 8-bit input port. Port 7 pins also function as the A/D converter analog input pins, D/A converter analog output pins, and interrupt input pins. Port 7 has the following register.

- Port 7 input data register (P7PIN)

8.7.1 Port 7 Input Data Register (P7PIN)

P7PIN indicates the pin states.

Bit	Bit Name	Initial Value	R/W	Description
7	P77PIN	Undefined*	R	When a P7PIN read is performed, the pin states are always read. This register is assigned to the same address as that of PBDDR. When the register is programmed, data is programmed in the PBDDR and the setting of port B is changed.
6	P76PIN	Undefined*	R	
5	P75PIN	Undefined*	R	
4	P74PIN	Undefined*	R	
3	P73PIN	Undefined*	R	
2	P72PIN	Undefined*	R	
1	P71PIN	Undefined*	R	
0	P70PIN	Undefined*	R	

Note: The initial value is determined in accordance with the pin states of P77 to P70.

8.7.2 Pin Functions

Each pin of port 7 can also be used as the interrupt input pins ($\overline{\text{ExIRQ2}}$ to $\overline{\text{ExIRQ7}}$), analog input pin of the A/D converter (AN0 to AN7), and analog output pin (DA0, DA1) of the D/A converter. By setting the ISS bit of the ISSR to 1, the pins can also be used as the interrupt input pin ($\overline{\text{ExIRQ2}}$ to $\overline{\text{ExIRQ7}}$).

When the interrupt input pin is set, do not use the pins for the A/D or D/A converter.

- P77/ $\overline{\text{ExIRQ7}}$ /AN7/DA1

The port 7 function changes as shown in the following table, depending on the combination of the CH2 to CH0 bits of ADCSR of the A/D converter, the DAOE1 bit of DACR of the D/A converter, and the ISS7 bit of ISSR of the interrupt controller. Do not set these bits to other values than those shown in the following table.

CH2 to CH0	B'111	Other than B'111		
DAOE1	0	0		1
ISS7	0	0	1	0
Pin function	AN7 input pin	P77 input pin	$\overline{\text{ExIRQ7}}$ input pin	DA1 output pin

- P76/ $\overline{\text{ExIRQ6}}$ /AN6/DA0

The port 7 function changes as shown in the following table, depending on the combination of the SCAN bit and the CH2 to CH0 bits of ADCSR of the A/D converter, the DAOE0 bit of DACR of the D/A converter, and the ISS6 bit of ISSR of the interrupt controller. Do not set these bits to other values than those shown in the following table.

SCAN	0				1			
CH2 to CH0	B'110	Other than B'110			B'11*	Other than B'11*		
DAOE0	0	0	1	0	0	0	1	0
ISS6	0	0	1	0	0	0	1	0
Pin function	AN6 input pin	P76 input pin	$\overline{\text{ExIRQ6}}$ input pin	DA0 output pin	AN6 input pin	P76 input pin	$\overline{\text{ExIRQ6}}$ input pin	DA0 output pin

[Legend]

*: Don't care

- P75/ $\overline{\text{ExIRQ5}}$ /AN5

The port 7 function changes as shown in the following table, depending on the combination of the SCAN bit and the CH2 to CH0 bits of ADCSR of the A/D converter and the ISS5 bit of ISSR of the interrupt controller. Do not set these bits to other values than those shown in the following table.

SCAN	0			1		
CH2 to CH0	B'101	Other than B'101		B'101, B'11*	Other than B'101 and B'11*	
ISS5	0	0	1	0	0	1
Pin function	AN5 input pin	P75 input pin	$\overline{\text{ExIRQ5}}$ input pin	AN5 input pin	P75 input pin	$\overline{\text{ExIRQ5}}$ input pin

[Legend]

*: Don't care

- P74/ $\overline{\text{ExIRQ4}}$ /AN4

The port 7 function changes as shown in the following table, depending on the combination of the SCAN bit and the CH2 to CH0 bits of ADCSR of the A/D converter and the ISS4 bit of ISSR of the interrupt controller. Do not set these bits to other values than those shown in the following table.

SCAN	0			1		
CH2 to CH0	B'100	Other than B'100		B'1**	Other than B'1**	
ISS4	0	0	1	0	0	1
Pin function	AN4 input pin	P74 input pin	$\overline{\text{ExIRQ4}}$ input pin	AN4 input pin	P74 input pin	$\overline{\text{ExIRQ4}}$ input pin

[Legend]

*: Don't care

- P73/ $\overline{\text{ExIRQ3}}$ /AN3

The port 7 function changes as shown in the following table, depending on the combination of the CH2 to CH0 bits of ADCSR of the A/D converter and the ISS3 bit of ISSR of the interrupt controller. Do not set these bits to other values than those shown in the following table.

CH2 to CH0	B'011	Other than B'011	
ISS3	0	0	1
Pin function	AN3 input pin	P73 input pin	$\overline{\text{ExIRQ3}}$ input pin

- P72/ $\overline{\text{ExIRQ2}}$ /AN2

The port 7 function changes as shown in the following table, depending on the combination of the SCAN bit and the CH2 to CH0 bits of ADCSR of the A/D converter and the ISS2 bit of ISSR of the interrupt controller. Do not set these bits to other values than those shown in the following table.

SCAN	0			1		
CH2 to CH0	B'010	Other than B'010		B'01*	Other than B'01*	
ISS2	0	0	1	0	0	1
Pin function	AN2 input pin	P72 input pin	$\overline{\text{ExIRQ2}}$ input pin	AN2 input pin	P72 input pin	$\overline{\text{ExIRQ2}}$ input pin

[Legend]

*: Don't care

- P71/AN1

The port 7 function changes as shown in the following table, depending on the combination of the SCAN bit and the CH2 to CH0 bits of ADCSR of the A/D converter. Do not set these bits to other values than those shown in the following table.

SCAN	0		1	
CH2 to CH0	B'001	Other than B'001	B'001, B'01*	Other than B'001 and B'01*
Pin function	AN1 input pin	P71 input pin	AN1 input pin	P71 input pin

[Legend]

*: Don't care

- P70/AN0

The port 7 function changes as shown in the following table, depending on the combination of the SCAN bit and the CH2 to CH0 bits of ADCSR of the A/D converter. Do not set these bits to other values than those shown in the following table.

SCAN	0		1	
CH2 to CH0	B'000	Other than B'000	B'0**	Other than B'0**
Pin function	AN0 input pin	P70 input pin	AN0 input pin	P70 input pin

[Legend]

*: Don't care

8.8 Port 8

Port 8 is an 8-bit I/O port. Port 8 pins also function as the A/D converter external trigger input pin, SCI_0, SCI_1, and SCI_2 clock input/output pins, IIC_0 and IIC_1 input/output pins, TMR_0, TMR_1, TMR_X, and TMR_Y input pins, and interrupt input pins. Port 8 is an NMOS push-pull output. Port 8 has the following registers.

- Port 8 data direction register (P8DDR)
- Port 8 data register (P8DR)

8.8.1 Port 8 Data Direction Register (P8DDR)

The individual bits of P8DDR specify input or output for the pins of port 8.

Bit	Bit Name	Initial Value	R/W	Description
7	P87DDR	0	W	This register is assigned to the same address as that of PBPIN. When this register is read, the port B states are read.
6	P86DDR	0	W	
5	P85DDR	0	W	If port 8 pins are specified for use as the general I/O port, the corresponding port 8 pins are output ports when the P8DDR bits are set to 1, and input ports when cleared to 0.
4	P84DDR	0	W	
3	P83DDR	0	W	
2	P82DDR	0	W	
1	P81DDR	0	W	
0	P80DDR	0	W	

8.8.2 Port 8 Data Register (P8DR)

P8DR stores output data for the port 8 pins.

Bit	Bit Name	Initial Value	R/W	Description
7	P87DR	0	R/W	P8DR stores output data for the port 8 pins that are used as the general output port.
6	P86DR	0	R/W	
5	P85DR	0	R/W	If a port 8 read is performed while the P8DDR bits are set to 1, the P8DR values are read. If a port 8 read is performed while the P8DDR bits are cleared to 0, the pin states are read.
4	P84DR	0	R/W	
3	P83DR	0	R/W	
2	P82DR	0	R/W	
1	P81DR	0	R/W	
0	P80DR	0	R/W	

8.8.3 Pin Functions

The relationship between register setting values and pin functions are as follows.

- P87/ $\overline{\text{ExIRQ15}}$ / $\overline{\text{ADTRG}}$ / $\overline{\text{ExTMIY}}$

The pin function is switched as shown below according to the P87DDR bit.

When the TRGS1 and TRGS0 bits in ADCR of the A/D converter are both set to 1, this pin can be used as the $\overline{\text{ADTRG}}$ input pin.

When the ISS15 bit in ISSR16 of the interrupt controller is set to 1, this pin can be used as the $\overline{\text{ExIRQ15}}$ input pin. When the TMIYS bit in PTCNT0 is set to 1, this pin can be used as the TMIY (TMCIX/TMRIY) input pin. To use this pin as the $\overline{\text{ExIRQ15}}$ input pin, clear the P87DDR bit to 0.

When this pin is used as the P87 output pin, the output format is NMOS push-pull output.

P87DDR	0	1
Pin function	P87 input pin	P87 output pin
	$\overline{\text{ExIRQ15}}$ input pin	
	$\overline{\text{ADTRG}}$ input pin	
	$\overline{\text{ExTMIY}}$ input pin	

- P86/ $\overline{\text{ExIRQ14}}$ /SCK2/ $\overline{\text{ExTMIX}}$

The pin function is switched as shown below according to the combination of the C/\overline{A} bit in SMR of SCI_2, the CKE1 and CKE0 bits in SCR, and the P86DDR bit.

When the ISS14 bit in ISSR16 of the interrupt controller is set to 1, this pin can be used as the $\overline{\text{ExIRQ14}}$ input pin. When the TMIXS bit in PTCNT0 is set to 1, this pin can be used as the TMIX (TMCIX/TMRIX) input pin. To use this pin as the $\overline{\text{ExIRQ14}}$ input pin, clear the P86DDR bit to 0.

When this pin is used as the P86 output pin, the output format is NMOS push-pull output.

CKE1	0			1	
C/\overline{A}	0		1	—	
CKE0	0		1	—	—
P86DDR	0	1	—	—	—
Pin function	P86 input pin	P86 output pin	SCK2 output pin	SCK2 output pin	SCK2 input pin
	$\overline{\text{ExIRQ14}}$ input pin $\overline{\text{ExTMIX}}$ input pin				

- P85/ $\overline{\text{ExIRQ13}}$ /SCK1/ExTMI1

The pin function is switched as shown below according to the combination of the C/\overline{A} bit in SMR of SCI_1, the CKE1 and CKE0 bits in SCR, and the P85DDR bit.

When the ISS13 bit in ISSR16 of the interrupt controller is set to 1, this pin can be used as the $\overline{\text{ExIRQ13}}$ input pin. When the TMI1S bit in PTCNT0 is set to 1, this pin can be used as the TMI1 (TMI1/TMR11) input pin. To use this pin as the $\overline{\text{ExIRQ13}}$ input pin, clear the P85DDR bit to 0.

When this pin is used as the P85 output pin, the output format is NMOS push-pull output.

CKE1	0				1
C/\overline{A}	0			1	—
CKE0	0		1	—	—
P85DDR	0	1	—	—	—
Pin function	P85 input pin	P85 output pin	SCK1 output pin	SCK1 output pin	SCK1 input pin
	$\overline{\text{ExIRQ13}}$ input pin /ExTMI1 input pin				

- P84/ $\overline{\text{ExIRQ12}}$ /SCK0/ExTMI0

The pin function is switched as shown below according to the combination of the C/\overline{A} bit in SMR of SCI_0, the CKE1 and CKE0 bits in SCR, and the P84DDR bit.

When the ISS12 bit in ISSR16 of the interrupt controller is set to 1, this pin can be used as the $\overline{\text{ExIRQ12}}$ input pin. When the TMI0S bit in PTCNT0 is set to 1, this pin can be used as the TMI0 (TMI0/TMR10) input pin. To use this pin as the $\overline{\text{ExIRQ12}}$ input pin, clear the P84DDR bit to 0.

When this pin is used as the P84 output pin, the output format is NMOS push-pull output.

CKE1	0				1
C/\overline{A}	0			1	—
CKE0	0		1	—	—
P84DDR	0	1	—	—	—
Pin function	P84 input pin	P84 output pin	SCK0 output pin	SCK0 output pin	SCK0 input pin
	$\overline{\text{ExIRQ12}}$ input pin /ExTMI0 input pin				

- P83/ $\overline{\text{ExIRQ11}}$ /SDA1

The pin function is switched as shown below according to the combination of the ICE bit in ICCR of IIC_1 and the P83DDR bit.

When the ISS11 bit in ISSR16 of the interrupt controller is set to 1, this pin can be used as the $\overline{\text{ExIRQ11}}$ input pin. To use this pin as the $\overline{\text{ExIRQ11}}$ input pin, clear the P83DDR bit to 0.

When this pin is used as the P83 output pin, the output format is NMOS push-pull output. The output format for SDA1 is NMOS open-drain output, and direct bus drive is possible.

ICE	0		1
P83DDR	0	1	—
Pin function	P83 input pin	P83 output pin	SDA1 input/output pin
	$\overline{\text{ExIRQ11}}$ input pin		

- P82/ $\overline{\text{ExIRQ10}}$ /SCL1

The pin function is switched as shown below according to the combination of the ICE bit in ICCR of IIC_1 and the P82DDR bit.

When the ISS10 bit in ISSR16 of the interrupt controller is set to 1, this pin can be used as the $\overline{\text{ExIRQ10}}$ input pin. To use this pin as the $\overline{\text{ExIRQ10}}$ input pin, clear the P82DDR bit to 0.

When this pin is used as the P82 output pin, the output format is NMOS push-pull output. The output format for SCL1 is NMOS open-drain output, and direct bus drive is possible.

ICE	0		1
P82DDR	0	1	—
Pin function	P82 input pin	P82 output pin	SCL1 input/output pin
	$\overline{\text{ExIRQ10}}$ input pin		

- P81/ $\overline{\text{ExIRQ9}}$ /SDA0

The pin function is switched as shown below according to the combination of the ICE bit in ICCR of IIC_0 and the P81DDR bit.

When the ISS9 bit in ISSR16 of the interrupt controller is set to 1, this pin can be used as the $\overline{\text{ExIRQ9}}$ input pin. To use this pin as the $\overline{\text{ExIRQ9}}$ input pin, clear the P81DDR bit to 0.

When this pin is used as the P81 output pin, the output format is NMOS push-pull output. The output format for SDA0 is NMOS open-drain output, and direct bus drive is possible.

ICE	0		1
P81DDR	0	1	—
Pin function	P81 input pin	P81 output pin	SDA0 input/output pin
	$\overline{\text{ExIRQ9}}$ input pin		

- P80/ $\overline{\text{ExIRQ8}}$ /SCL0

The pin function is switched as shown below according to the combination of the ICE bit in ICCR of IIC_0 and the P80DDR bit.

When the ISS8 bit in ISSR16 of the interrupt controller is set to 1, this pin can be used as the $\overline{\text{ExIRQ8}}$ input pin. To use this pin as the $\overline{\text{ExIRQ8}}$ input pin, clear the P80DDR bit to 0.

When this pin is used as the P80 output pin, the output format is NMOS push-pull output. The output format for SCL0 is NMOS open-drain output, and direct bus drive is possible.

ICE	0		1
P80DDR	0	1	—
Pin function	P80 input pin	P80 output pin	SCL0 input/output pin
	$\overline{\text{ExIRQ8}}$ input pin		

8.9 Port 9

Port 9 is an 8-bit I/O port. Port 9 pins also function as the bus control I/O pins or the system clock output pin. Pin functions are switched depending on the operating mode. Port 9 has the following registers.

- Port 9 data direction register (P9DDR)
- Port 9 data register (P9DR)

8.9.1 Port 9 Data Direction Register (P9DDR)

The individual bits of P9DDR specify input or output for the pins of port 9.

Bit	Bit Name	Initial Value	R/W	Description
7	P97DDR	0	W	If port 9 pins are specified for use as the general I/O port, the corresponding port 9 pins are output ports when the P9DDR bits are set to 1, and input ports when cleared to 0.
6	P96DDR	0	W	When this bit is set to 1, the corresponding port 96 pin is the system clock output pin (ϕ), and as a general input port when cleared to 0.
5	P95DDR	0	W	If port 9 pins are specified for use as the general I/O port, the corresponding port 9 pins are output ports when the P9DDR bits are set to 1, and input ports when cleared to 0.
4	P94DDR	0	W	
3	P93DDR	0	W	If port 9 pins are specified for use as the general I/O port, the corresponding port 9 pins are output ports when the P9DDR bits are set to 1, and input ports when cleared to 0.
2	P92DDR	0	W	
1	P91DDR	0	W	If port 9 pins are specified for use as the general I/O port, the corresponding port 9 pins are output ports when the P9DDR bits are set to 1, and input ports when cleared to 0.
0	P90DDR	0	W	

8.9.2 Port 9 Data Register (P9DR)

P9DR stores output data for the port 9 pins.

Bit	Bit Name	Initial Value	R/W	Description
7	P97DR	0	R/W	P9DR stores output data for the port 9 pins that are used as the general output port except for bit 6.
6	P96DR	Undefined*	R	
5	P95DR	0	R/W	If a port 9 read is performed while the P9DDR bits are set to 1, the P9DR values are read. If a port 9 read is performed while the P9DDR bits are cleared to 0, the pin states are read.
4	P94DR	0	R/W	
3	P93DR	0	R/W	
2	P92DR	0	R/W	
1	P91DR	0	R/W	
0	P90DR	0	R/W	

Note: The initial value of bit 6 is determined in accordance with the P96 pin state.

8.9.3 Pin Functions

The relationship between the operating mode, register setting values, and pin functions are as follows.

- P97/ $\overline{\text{WAIT}}$ / $\overline{\text{CS256}}$

The pin function is switched as shown below according to the combination of the operating mode, the CS256E bit in SYSCR, the WMS1 bit in WSCR, the WMS21 bit in WSCR2, and the P97DDR bit.

Operating Mode	Extended Mode				Single-Chip Mode	
	WMS1, WMS21	All 0		One bit is set as 1		—
CS256E	0		1		—	
P97DDR	0	1	—		0	1
Pin function	P97 input pin	P97 output pin	$\overline{\text{CS256}}$ output pin	$\overline{\text{WAIT}}$ input pin	P97 input pin	P97 output pin

- P96/ ϕ /EXCL

The pin function is switched as shown below according to the combination of the EXCLE bit in LPWRCR and the P96DDR bit.

P96DDR	0		1
EXCLE	0	1	—
Pin function	P96 input pin	EXCL input pin	ϕ output pin

- P95/ \overline{AS} / \overline{IOS}

The pin function is switched as shown below according to the combination of the operating mode, the IOSE bit in SYSCR, and the P95DDR bit.

Operating Mode	Extended Mode		Single-Chip Mode	
P95DDR	—		0	1
IOSE	0	1	—	
Pin function	\overline{AS} output pin	\overline{IOS} output pin	P95 input pin	P95 output pin

- P94/ \overline{HWR}

The pin function is switched as shown below according to the combination of the operating mode and the P94DDR bit.

Operating Mode	Extended Mode	Single-Chip Mode	
P94DDR	—	0	1
Pin function	\overline{HWR} output pin	P94 input pin	P94 output pin

- P93/ \overline{RD}

The pin function is switched as shown below according to the combination of the operating mode and the P93DDR bit.

Operating Mode	Extended Mode	Single-Chip Mode	
P93DDR	—	0	1
Pin function	\overline{RD} output pin	P93 input pin	P93 output pin

- P92/ $\overline{\text{CPCS1}}$

The pin function is switched as shown below according to the combination of the operating mode, the CPCSE bit in BCR2 of BSC, and the P92DDR bit.

Operating Mode	Extended Mode			Single-Chip Mode	
	CPCSE	0		1	—
P92DDR	0	1	—	0	1
Pin function	P92 input pin	P92 output pin	$\overline{\text{CPCS1}}$ output pin	P92 input pin	P92 output pin

- P91/ $\overline{\text{AH}}$

The pin function is switched as shown below according to the combination of the operating mode, the ADMXE bit of SYSCR2, and the P91DDR bit.

Operating Mode	Extended Mode			Single-Chip Mode	
	ADMXE	0		1	—
P91DDR	0	1	—	0	1
Pin function	P91 input pin	P91 output pin	$\overline{\text{AH}}$ output pin	P91 input pin	P91 output pin

- P90/ $\overline{\text{LWR}}$

The pin function is switched as shown below according to the combination of the operating mode, the ABW and ABW256 bits in WSCR, the ABWCP bit in BCR2, and the P90DDR bit.

Operating Mode	Extended Mode			Single-Chip Mode	
	ABW, ABW256, ABWCP	All 1		One bit is set as 0	—
P90DDR	0	1	—	0	1
Pin function	P90 input pin	P90 output pin	$\overline{\text{LWR}}$ output pin	P90 input pin	P90 output pin

8.10 Port A

Port A is an 8-bit I/O port. Port A pins also function as the address output, event counter input, keyboard input, and SCI_0 and SCI_2 external control pins. Pin functions are switched depending on the operating mode. Port A has the following registers. PADDR and PAPIN have the same address.

- Port A data direction register (PADDR)
- Port A output data register (PAODR)
- Port A input data register (PAPIN)

8.10.1 Port A Data Direction Register (PADDR)

The individual bits of PADDR specify input or output for the pins of port A.

Bit	Bit Name	Initial Value	R/W	Description
7	PA7DDR	0	W	In normal extended mode:
6	PA6DDR	0	W	The corresponding port A pins are address output
5	PA5DDR	0	W	ports when the PADDR bits are set to 1, and input
4	PA4DDR	0	W	ports when cleared to 0. Pins function as the address
3	PA3DDR	0	W	output port depending on the setting of bits IOSE,
2	PA2DDR	0	W	CS256E, CPCSE, ADFULLE in bus controller.
1	PA1DDR	0	W	In other mode:
0	PA0DDR	0	W	The corresponding port A pins are output ports when
				the PADDR bits are set to 1, and input ports when
				cleared to 0.

8.10.2 Port A Output Data Register (PAODR)

PAODR stores output data for the port A pins.

Bit	Bit Name	Initial Value	R/W	Description
7	PA7ODR	0	R/W	PAODR stores output data for the port A pins that are used as the general output port.
6	PA6ODR	0	R/W	
5	PA5ODR	0	R/W	
4	PA4ODR	0	R/W	
3	PA3ODR	0	R/W	
2	PA2ODR	0	R/W	
1	PA1ODR	0	R/W	
0	PA0ODR	0	R/W	

8.10.3 Port A Input Data Register (PAPIN)

PAPIN indicates the pin states.

Bit	Bit Name	Initial Value	R/W	Description
7	PA7PIN	Undefined*	R	When a PAPIN read is performed, the pin states are always read.
6	PA6PIN	Undefined*	R	
5	PA5PIN	Undefined*	R	
4	PA4PIN	Undefined*	R	
3	PA3PIN	Undefined*	R	
2	PA2PIN	Undefined*	R	
1	PA1PIN	Undefined*	R	
0	PA0PIN	Undefined*	R	

Note: The initial values are determined in accordance with the pin states of PA7 to PA0.

8.10.4 Pin Functions

The relationship between the operating mode, register setting values, and pin functions are as follows.

Normal Extended Mode: Port A functions as address output, keyboard input, external control input of SCI_0 and SCI_2, and also as an I/O port, and input or output can be specified in bit units.

Address 18 and 13 in the following table are expressed by the following logical expressions:

$$\text{Address 18} = 1:\overline{\text{ADFULLE}}$$

$$\text{Address 13} = 1:\overline{\text{ADFULLE}} \cdot \overline{\text{CS256E}} \cdot (\text{CPCSE} \mid \text{IOSE})$$

- PA7/ $\overline{\text{KIN15}}$ /EVENT7/A23, PA6/ $\overline{\text{KIN14}}$ /EVENT6/A22, PA5/ $\overline{\text{KIN13}}$ /EVENT5/A21, PA4/ $\overline{\text{KIN12}}$ /EVENT4/A20, PA3/ $\overline{\text{KIN11}}$ /EVENT3/A19, PA2/ $\overline{\text{KIN10}}$ /EVENT2/A18

The function of port A pins is switched according to the combination of address 18 setting and the PAnDDR bit. When the KMIM bit in KMIMRA of the interrupt controller is cleared to 0, this pin can be used as the $\overline{\text{KIN}}$ input pin. To use this pin as the $\overline{\text{KIN}}$ input pin, clear the PAnDDR bit to 0. When this pin is used as EVENT input pin according to bits ECSB3 to ECSB0 in ECCR of the data transfer controller settings, clear the PAnDDR bit to 0. Though this pin has been set to the EVENT input pin, to use as the PAn or A1 output pin, set the PAnDDR bit to 1.

PAnDDR	0	1	1
Address 18	1	1	0
Pin function	PAn input pins	PAn output pin	A1 output pin
	$\overline{\text{KIN}}_m$ input pin EVENT _n input pin		

[Legend]

n = 7 to 2

m = 15 to 10

l = 23 to 18

- PA1/ $\overline{\text{KIN9}}$ /EVENT1/A17/SSE2I

The function of port A pins is switched as shown below according to the combination of the SSE bit in SEMR of SCI_2, the $\overline{\text{C/A}}$ bit in SMR, the CKE1 bit in SCR, address 13 setting, and the PA1DDR bit.

When the KMIM9 bit in KMIMRA of the interrupt controller is cleared to 0, this pin can be used as the $\overline{\text{KIN9}}$ input pin. To use this pin as the $\overline{\text{KIN9}}$ input pin, clear the PA1DDR bit to 0. When this pin is used as EVENT1 input pin according to bits ECSB3 to ECSB0 in ECCR of the data transfer controller settings, clear the PA1DDR bit to 0. Though this pin has been set to the EVENT1 input pin, to use as the PA1 or A17 output pin, set the PA1DDR bit to 1.

SSE	0			1
C/ \bar{A}	—			1
CEK1	—			1
PA1DDR	0	1	1	—
Address 13	1		0	—
Pin function	PA1 input pin	PA1 output pin	A17 output pin	SSE2I input pin
	$\bar{KIN9}$ input pin			
	/EVENT1 input pin			

- PA0/ $\bar{KIN8}$ /EVENT0/A16/SSE0I

The function of port A pins is switched as shown below according to the combination of the SSE bit in SEMR of SCI_0, the C/ \bar{A} bit in SMR, the CEK1 bit in SCR, address 13 setting, and the PA0DDR bit.

When the KMIM8 bit in KMIMRA of the interrupt controller is cleared to 0, this pin can be used as the $\bar{KIN8}$ input pin. To use this pin as the $\bar{KIN8}$ input pin, clear the PA0DDR bit to 0. When this pin is used as EVENT0 input pin according to bits ECSB3 to ECSB0 in ECCR of the data transfer controller settings, clear the PA0DDR bit to 0. Though this pin has been set to the EVENT0 input pin, to use as the PA0 or A16 output pin, set the PA0DDR bit to 1.

SSE	0			1
C/ \bar{A}	—			1
CKE1	—			1
PA0DDR	0	1	1	—
Address 13	1		0	—
Pin function	PA0 input pin	PA0 output pin	A16 output pin	SSE0I input pin
	$\bar{KIN8}$ input pin			
	/EVENT0 input pin			

Single-Chip Mode and Address-Data Multiplex Extended Mode: Port A functions as keyboard input, external control input of SCI_0 and SCI_2, and also as an I/O port, and input or output can be specified in bit units.

- PA7/ $\bar{KIN15}$ /EVENT7, PA6/ $\bar{KIN14}$ /EVENT6, PA5/ $\bar{KIN13}$ /EVENT5, PA4/ $\bar{KIN12}$ /EVENT4, PA3/ $\bar{KIN11}$ /EVENT3, PA2/ $\bar{KIN10}$ /EVENT2

When the KMIM bit in KMIMRA of the interrupt controller is cleared to 0, this pin can be used as the \bar{KIN} input pin. To use this pin as the \bar{KIN} input pin, clear the PAnDDR bit to 0. When this pin is used as the EVENT input pin according to bits ECSB3 to ECSB0 in ECCR of the data transfer controller settings, clear the PAnDDR bit to 0. Though this pin has been set to the EVENT input pin, to use as the PAn output pins, set the PAnDDR bit to 1.

PA n DDR	0	1
Pin function	PAn input pins	
	$\overline{\text{KIN}}_m$ input pin/EVENT n input pins	

[Legend]

n = 7 to 2

m = 15 to 10

- PA1/ $\overline{\text{KIN}}_9$ /EVENT1/SSE2I

The function of port A pins is switched as shown below according to the combination of the SSE bit in SEMR of SCI_2, the C/ $\overline{\text{A}}$ bit in SMR, the CKE1 bit in SCR, and the PA1DDR bit. When the $\overline{\text{KMIM}}_9$ bit in KMIMRA of the interrupt controller is cleared to 0, this pin can be used as the $\overline{\text{KIN}}_9$ input pin. To use this pin as the $\overline{\text{KIN}}_9$ input pin, clear the PA1DDR bit to 0. When this pin is used as the EVENT1 input pin according to bits ECSB3 to ECSB0 in ECCR of the data transfer controller settings, clear the PA1DDR bit to 0. Though this pin has been set to the EVENT1 input pin, to use as the PA1 output pin, set the PA1DDR bit to 1.

SSE	0		1
C/ $\overline{\text{A}}$	—		1
CKE1	—		1
PA1DDR	0	1	—
Pin function	PA1 input pin	PA1 output pin	SSE2I input pin
	$\overline{\text{KIN}}_9$ input pin /EVENT1 input pin		

- PA0/ $\overline{\text{KIN}}_8$ /EVENT0/SSE0I

The function of port A pins is switched as shown below according to the combination of the SSE bit in SEMR of SCI_0, the C/ $\overline{\text{A}}$ bit in SMR, the CKE1 bit in SCR, and the PA0DDR bit. When the $\overline{\text{KMIM}}_8$ bit in KMIMRA of the interrupt controller is cleared to 0, this pin can be used as the $\overline{\text{KIN}}_8$ input pin. To use this pin as the $\overline{\text{KIN}}_8$ input pin, clear the PA0DDR bit to 0. When this pin is used as the EVENT0 input pin according to bits ECSB3 to ECSB0 in ECCR of the data transfer controller settings, clear the PA0DDR bit to 0. Though this pin has been set to the EVENT0 input pin, to use as the PA0 output pin, set the PA0DDR bit to 1.

SSE	0		1
C/ \bar{A}	—		1
CKE1	—		1
PA0DDR	0	1	—
Pin function	PA0 input pin	PA0 output pin	SSE0I
	$\overline{KIN8}$ input pin /EVENT0 input pin		

8.10.5 Input Pull-Up MOS

Port A has a built-in input pull-up MOS that can be controlled by software. This input pull-up MOS can be used in any operating mode, and can be specified as on or off on a bit-by-bit basis.

PAnDDR	0		1
PAnODR	1	0	—
PAn pull-up MOS	ON	OFF	OFF

[Legend]

n = 7 to 0

The input pull-up MOS is in the off state after a reset and in hardware standby mode. The prior state is retained in software standby mode.

Table 8.6 summarizes the input pull-up MOS states.

Table 8.6 Port A Input Pull-Up MOS States

Reset	Hardware Standby Mode	Software Standby Mode	In Other Operations
Off	Off	On/Off	On/Off

[Legend]

Off: Always off.

On/Off: On when PADDR = 0 and PAODR = 1; otherwise off.

8.11 Port B

Port B is an 8-bit multi-function input/output port that can also be used event counter input pin. Port B has the following registers.

- Port B data direction register (PBDDR)
- Port B output data register (PBODR)
- Port B input data register (PBPIN)

8.11.1 Port B Data Direction Register (PBDDR)

PBDDR is used to specify the input/output attribute of each pin of port B.

Bit	Bit Name	Initial Value	R/W	Description
7	PB7DDR	0	W	The corresponding port B pins are output ports when the PBDDR bits are set to 1, and input ports when cleared to 0.
6	PB6DDR	0	W	
5	PB5DDR	0	W	
4	PB4DDR	0	W	
3	PB3DDR	0	W	
2	PB2DDR	0	W	
1	PB1DDR	0	W	
0	PB0DDR	0	W	

8.11.2 Port B Output Data Register (PBODR)

PBODR stores output data for the port B pins.

Bit	Bit Name	Initial Value	R/W	Description
7	PB7ODR	0	R/W	The PBODR register stores the output data for the pins that are used a general output port.
6	PB6ODR	0	R/W	
5	PB5ODR	0	R/W	
4	PB4ODR	0	R/W	
3	PB3ODR	0	R/W	
2	PB2ODR	0	R/W	
1	PB1ODR	0	R/W	
0	PB0ODR	0	R/W	

8.11.3 Port B Input Data Register (PBPIN)

PBPIN indicates the pin states.

Bit	Bit Name	Initial Value	R/W	Description
7	PB7PIN	Undefined*	R	Pin states can be read by performing a read cycle on this register.
6	PB6PIN	Undefined*	R	
5	PB5PIN	Undefined*	R	This register is assigned to the same address as that of P8DDR. When this register is written to, data is written to P8DDR and the port 8 setting is then changed.
4	PB4PIN	Undefined*	R	
3	PB3PIN	Undefined*	R	
2	PB2PIN	Undefined*	R	
1	PB1PIN	Undefined*	R	
0	PB0PIN	Undefined*	R	

Note: The initial value of these pins is determined in accordance with the state of pins PB7 to PB0.

8.11.4 Pin Functions

Port B is a multi-function port that can function as an event counter input pin. The relationship between the operating mode setup and pin functions is described below.

When this pin is used as the EVENT input pin according to bits ECSB3 to ECSB0 in ECCR of the data transfer controller settings, clear the P_BnDDR bit to 0. (n = 7 to 0)

- PB7/EVENT15

PB7DDR	0		1
Event counter ^{*1}	Disable	Enable	—
Pin function	PB7 input pin	EVENT15 input pin	PB7 output pin

- PB6/EVENT14

PB6DDR	0		1
Event counter ^{*1}	Disable	Enable	—
Pin function	PB6 input pin	EVENT14 input pin	PB6 output pin

- PB5/ EVENT13

PB5DDR	0		1
Event counter* ¹	Disable	Enable	—
Pin function	PB5 input pin	EVENT13 input pin	PB5 output pin

- PB4/ EVENT12

PB4DDR	0		1
Event counter* ¹	Disable	Enable	—
Pin function	PB4 input pin	EVENT12 input pin	PB4 output pin

- PB3/ EVENT11

PB3DDR	0		1
Event counter* ¹	Disable	Enable	—
Pin function	PB3 input pin	EVENT11 input pin	PB3 output pin

- PB2/ EVENT10

PB2DDR	0		1
Event counter* ¹	Disable	Enable	—
Pin function	PB2 input pin	EVENT10 input pin	PB2 output pin

- PB1/ EVENT9

PB1DDR	0		1
Event counter* ¹	Disable	Enable	—
Pin function	PB1 input pin	EVENT9 input pin	PB1 output pin

- PB0/ EVENT8

PB0DDR	0		1
Event counter* ¹	Disable	Enable	—
Pin function	PB0 input pin	EVENT8 input pin	PB0 output pin

Note: For event counter setting, refer to section 7, Data Transfer Controller (DTC).

8.12 Port C

Port C is an 8-bit multi-function I/O port that functions as PWMX output pins or input/output pins of IIC_2, 3, 4. The output format of ports C0 to C5 is NMOS push-pull output.

Port C has the following registers.

- Port C data direction register (PCDDR)
- Port C output data register (PCODR)
- Port C input data register (PCPIN)

8.12.1 Port C Data Direction Register (PCDDR)

PCDDR is used to specify the input/output attribute of each pin of port C.

Bit	Bit Name	Initial Value	R/W	Description
7	PC7DDR	0	W	When a given bit is set to 1, the corresponding pin will function as an output port, and when cleared to 0, it functions as an input port.
6	PC6DDR	0	W	
5	PC5DDR	0	W	This register is assigned to the same address as that of PCPIN. When this address is read, the port C states are returned.
4	PC4DDR	0	W	
3	PC3DDR	0	W	
2	PC2DDR	0	W	
1	PC1DDR	0	W	
0	PC0DDR	0	W	

8.12.2 Port C Output Data Register (PCODR)

PCODR stores output data for port C.

Bit	Bit Name	Initial Value	R/W	Description
7	PC7ODR	0	R/W	The PCODR register stores the output data for the pins that are used as a general output port.
6	PC6ODR	0	R/W	
5	PC5ODR	0	R/W	
4	PC4ODR	0	R/W	
3	PC3ODR	0	R/W	
2	PC2ODR	0	R/W	
1	PC1ODR	0	R/W	
0	PC0ODR	0	R/W	

8.12.3 Port C Input Data Register (PCPIN)

PCPIN indicates the pin states of port C.

Bit	Bit Name	Initial Value	R/W	Description
7	PC7PIN	Undefined* ¹	R	When this register is read, the pin state is read.
6	PC6 PIN	Undefined* ¹	R	This register is assigned to the same address as that of PCDDR. When this register is written to, data is written to PCDDR and the port C setting is then changed.
5	PC5 PIN	Undefined* ¹	R	
4	PC4 PIN	Undefined* ¹	R	
3	PC3 PIN	Undefined* ¹	R	
2	PC2 PIN	Undefined* ¹	R	
1	PC1 PIN	Undefined* ¹	R	
0	PC0 PIN	Undefined* ¹	R	

Note: The initial values are determined in accordance with the states of PC7 to PC0 pins.

8.12.4 Pin Functions

Port C is capable of functioning as the input and output of IIC_2, IIC_3, and IIC_4, and the PWMX output. The relationship between the register settings and pin function is described below.

- PC7/PWX3

The pin function is switched as shown below according to the combination of the OEB bit of the 14-bit PWMX DACR and the PC7DDR.

OEB	0		1
PC7DDR	0	1	—
Pin Function	PC7 input pin	PC7 output pin	PWX3 output pin

- PC6/PWX2

The pin function is switched as shown below according to the combination of the OEA bit of the 14-bit PWMX DACR and the PC6DDR.

OEA	0		1
PC6DDR	0	1	—
Pin Function	PC6 input pin	PC6 output pin	PWX2 output pin

- PC5/SDA4

The pin function is switched as shown below according to the combination of the ICE bit of the IIC_4 ICCR and the PC5DDR.

ICE	0		1
PC5DDR	0	1	—
Pin Function	PC5 input pin	PC5 output pin	SDA4 input/output pin

- PC4/SCL4

The pin function is switched as shown below according to the combination of the ICE bit of the IIC_4 ICCR and the PC4DDR.

ICE	0		1
PC4DDR	0	1	—
Pin Function	PC4 input pin	PC4 output pin	SCL4 input/output pin

- PC3/SDA3

The pin function is switched as shown below according to the combination of the ICE bit of the IIC_3 ICCR and the PC3DDR.

ICE	0		1
PC3DDR	0	1	—
Pin Function	PC3 input pin	PC3 output pin	SDA3 input/output pin

- PC2/SCL3

The pin function is switched as shown below according to the combination of the ICE bit of the IIC_3 ICCR and the PC2DDR.

ICE	0		1
PC2DDR	0	1	—
Pin Function	PC2 input pin	PC2 output pin	SCL3 input/output pin

- PC1/SDA2

The pin function is switched as shown below according to the combination of the ICE bit of the IIC_2 ICCR and the PC1DDR.

ICE	0		1
PC1DDR	0	1	—
Pin Function	PC1 input pin	PC1 output pin	SDA2 input/output pin

- PC0/SCL2

The pin function is switched as shown below according to the combination of the ICE bit of the IIC_2 ICCR and the PC0DDR.

ICE	0		1
PC0DDR	0	1	—
Pin Function	PC0 input pin	PC0 output pin	SCL2 input/output pin

8.13 Port D

Port D is an 8-bit multi-function I/O port that supports the following register set. Port D functions as both the IIC_5 I/O pin, and the LPC I/O pin. Ports D7 and D6 are NMOS push-pull outputs.

- Port D data direction register (PDDDR)
- Port D output data register (PDODR)
- Port D input data register (PDPIN)

8.13.1 Port D Data Direction Register (PDDDR)

PDDDR is used to specify the input/output attribute of each pin of port D.

Bit	Bit Name	Initial Value	R/W	Description
7	PD7DDR	0	W	When the general input/output port function is selected, and the given bit is set to 1, the corresponding pin will function as an output port, and when the bit is cleared to 0, the pin will function as an input port.
6	PD6DDR	0	W	
5	PD5DDR	0	W	
4	PD4DDR	0	W	This register is assigned to the same address as that of PDPIN. When this address is read, the port D states are returned.
3	PD3DDR	0	W	
2	PD2DDR	0	W	
1	PD1DDR	0	W	
0	PD0DDR	0	W	

8.13.2 Port D Output Data Register (PDODR)

PDODR stores output data for the port D pins.

Bit	Bit Name	Initial Value	R/W	Description
7	PD7ODR	0	R/W	The PDODR register stores the output data for the pins that are used a general output port.
6	PD6ODR	0	R/W	
5	PD5ODR	0	R/W	
4	PD4ODR	0	R/W	
3	PD3ODR	0	R/W	
2	PD2ODR	0	R/W	
1	PD1ODR	0	R/W	
0	PD0ODR	0	R/W	

8.13.3 Port D Input Data Register (PDPIN)

PDPIN indicates the pin states of port D.

Bit	Bit Name	Initial Value	R/W	Description
7	PD7PIN	Undefined*	R	Pin states can be read by performing a read cycle on this register.
6	PD6PIN	Undefined*	R	
5	PD5PIN	Undefined*	R	This register is assigned to the same address as that of PDDDR. When this register is written to, data is written to PDDDR and the port D setting is then changed.
4	PD4PIN	Undefined*	R	
3	PD3PIN	Undefined*	R	
2	PD2PIN	Undefined*	R	
1	PD1PIN	Undefined*	R	
0	PD0PIN	Undefined*	R	

Note: The initial value of these pins is determined in accordance with the state of pins PD7 to PD0.

8.13.4 Pin Functions

Port D is a multi-function port that functions as an LPC input/output and IIC_5 input/output. The relationship between the register settings and pin functions is described below.

The LPC module is disabled when the LPC1E, LPC2E, and LPC3E bits in HICR0 of LPC are all cleared to a 0.

- PD7/SDA5

The pin function is switched as shown below according to the combination of the ICE bit of the IIC_5 ICCR and the PD7DDR.

ICE	0		1
PD7DDR	0	1	—
Pin Function	PD7 input pin	PD7 output pin	SDA5 input/output pin

- PD6/SCL5

The pin function is switched as shown below according to the combination of the ICE bit of the IIC_5 ICCR and the PD6DDR.

ICE	0		1
PD6DDR	0	1	—
Pin Function	PD6 input pin	PD6 output pin	SCL5 input/output pin

- PD5/ $\overline{\text{LPCPD}}$

The pin function is switched as shown below according to the combination of LPC enabled/disabled and the PD5DDR.

LPC	Disabled		Enabled
PD5DDR	0	1	0
Pin Function	PD5 input pin	PD5 output pin	$\overline{\text{LPCPD}}$ input pin

- PD4/ $\overline{\text{CLKRUN}}$

The pin function is switched as shown below according to the combination of LPC enabled/disabled and the PD4DDR.

LPC	Disabled		Enabled
PD4DDR	0	1	0
Pin Function	PD4 input pin	PD4 output pin	$\overline{\text{CLKRUN}}$ input/output pin

- PD3/GA20

The pin function is switched as shown below according to the combination of the FGA20E bit of LPC HICR0 and the PD3DDR.

FGA20E	0		1
PD3DDR	0	1	0
Pin Function	PD3 input pin	PD3 output pin	GA20 output pin

- PD2/ $\overline{\text{PME}}$

The pin function is switched as shown below according to the combination of the PMEE bit of LPC HICR0 and the PD2DDR.

PMEE	0		1
PD2DDR	0	1	0
Pin Function	PD2 input pin	PD2 output pin	$\overline{\text{PME}}$ output pin

- PD1/ $\overline{\text{LSMI}}$

The pin function is switched as shown below according to the combination of the LSMIE bit of LPC HICR0 and the PD1DDR.

LSMIE	0		1
PD1DDR	0	1	0
Pin Function	PD1 input pin	PD1 output pin	$\overline{\text{LSMI}}$ output pin

- PD0/LSCI

The pin function is switched as shown below according to the combination of the LSCIE bit of LPC HICR0 and the PD0DDR.

LSCIE	0		1
PD0DDR	0	1	0
Pin Function	PD0 input pin	PD0 output pin	LSCI output pin

8.13.5 Input Pull-Up MOS

Ports D5 to D0 have a built-in input pull-up MOS that can be controlled by software. This input pull-up MOS can be used in any operating mode, and can be specified as on or off on a bit-by-bit basis.

PDnDDR	0		1
PDnODR	1	0	—
PDn pull-up MOS	ON	OFF	OFF

[Legend]

n = 5 to 0

The input pull-up MOS is in the off state after a reset and in hardware standby mode. The prior state is retained in software standby mode.

Table 8.7 summarizes the input pull-up MOS states.

Table 8.7 Port D Input Pull-Up MOS States

Reset	Hardware Standby Mode	Software Standby Mode	In Other Operations
Off	Off	On/Off	On/Off

[Legend]

Off: Always off.

On/Off: On when PDDDR = 0 and PDODR = 1; otherwise off.

8.14 Port E

Port E functions as an 8-bit input/output port and also as an LPC input/output. Port E provides the following register set.

- Port E data direction register (PEDDR)
- Port E output data register (PEODR)
- Port E input data register (PEPIN)

8.14.1 Port E Data Direction Register (PEDDR)

PEDDR is used to specify the input/output attribute of each pin of port E.

Bit	Bit Name	Initial Value	R/W	Description
7	PE7DDR	0	W	When a given bit of PEDDR is set to 1, the corresponding pin will function as an output port, and when cleared to 0, it will function as an input port.
6	PE6DDR	0	W	
5	PE5DDR	0	W	This register is assigned to the same address as that of PEPIN. When this address is read, the port E states are returned.
4	PE4DDR	0	W	
3	PE3DDR	0	W	
2	PE2DDR	0	W	
1	PE1DDR	0	W	
0	PE0DDR	0	W	

8.14.2 Port E Output Data Register (PEODR)

PEODR stores output data for the port E pins.

Bit	Bit Name	Initial Value	R/W	Description
7	PE7ODR	0	R/W	The PEODR register stores the output data for the pins that are used a general output port.
6	PE6ODR	0	R/W	
5	PE5ODR	0	R/W	
4	PE4ODR	0	R/W	
3	PE3ODR	0	R/W	
2	PE2ODR	0	R/W	
1	PE1ODR	0	R/W	
0	PE0ODR	0	R/W	

8.14.3 Port E Input Data Register (PEPIN)

PEPIN indicates the pin states of port E.

Bit	Bit Name	Initial Value	R/W	Description
7	PE7PIN	Undefined*	R	Pin states can be read by performing a read cycle on this register.
6	PE6PIN	Undefined*	R	
5	Pe5PIN	Undefined*	R	This register is assigned to the same address as that of PEDDR. When this register is written to, data is written to PEDDR and the port E setting is then changed.
4	PE4PIN	Undefined*	R	
3	PE3PIN	Undefined*	R	
2	PE2PIN	Undefined*	R	
1	PE1PIN	Undefined*	R	
0	PE0PIN	Undefined*	R	

Note: The initial value of these pins is determined in accordance with the state of pins PE7 to PE0.

8.14.4 Pin Functions

Port E also functions as an LPC input/output. The pin function is switched with LPC enabled or disabled. The LPC module is disabled when the LPC1E, LPC2E, and LPC3E bits in HICR0 of LPC are all 0.

- PE7/SERIRQ

The pin function is switched as shown below according to the LPC enabled/disabled and the PE7DDR.

LPC	Disabled		Enabled
PE7DDR	0	1	—
Pin Function	PE7 input pin	PE7 output pin	SERIRQ input/output pin

- PE6/LCLK

The pin function is switched as shown below according to the LPC enabled/disabled and the PE6DDR.

LPC	Disabled		Enabled
PE6DDR	0	1	—
Pin Function	PE6 input pin	PE6 output pin	LCLK input pin

- PE5/ $\overline{\text{LRESET}}$

The pin function is switched as shown below according to the LPC enabled/disabled and the PE5DDR.

LPC	Disabled		Enabled
PE5DDR	0	1	—
Pin Function	PE5 input pin	PE5 output pin	$\overline{\text{LRESET}}$ input pin

- PE4/ $\overline{\text{LFRAME}}$

The pin function is switched as shown below according to the LPC enabled/disabled and the PE4DDR.

LPC	Disabled		Enabled
PE4DDR	0	1	—
Pin Function	PE4 input pin	PE4 output pin	$\overline{\text{LFRAME}}$ input pin

- PE3/LAD3

The pin function is switched as shown below according to the LPC enabled/disabled and the PE3DDR.

LPC	Disabled		Enabled
PE3DDR	0	1	—
Pin Function	PE3 input pin	PE3 output pin	LAD3 input/output pin

- PE2/LAD2

The pin function is switched as shown below according to the LPC enabled/disabled and the PE2DDR.

LPC	Disabled		Enabled
PE2DDR	0	1	—
Pin Function	PE2 input pin	PE2 output pin	LAD2 input/output pin

- PE1/LAD1

The pin function is switched as shown below according to the LPC enabled/disabled and the PE1DDR.

LPC	Disabled		Enabled
PE1DDR	0	1	—
Pin Function	PE1 input pin	PE1 output pin	LAD1 input/output pin

- PE0/LAD0

The pin function is switched as shown below according to the LPC enabled/disabled and the PE0DDR.

LPC	Disabled		Enabled
PE0DDR	0	1	—
Pin Function	PE0 input pin	PE0 output pin	LAD0 input/output pin

8.15 Port F

Port F is a 3-bit multi-function input/output port supporting the following register set.

- Port F data direction register (PFDDR)
- Port F output data register (PFODR)
- Port F input data register (PFPIN)

8.15.1 Port F Data Direction Register (PFDDR)

PFDDR is used to specify the input/output attribute of each pin of port F.

Bit	Bit Name	Initial Value	R/W	Description
7 to 3	—	—	—	Reserved
2	PF2DDR	0	W	When the given bit of PFDDR is set to 1, the corresponding pin of port F will function as an output port, and when the bit is cleared to 0, the port pin will function as an input port. This register is assigned to the same address as that of PFPIN. When this address is read, the port F states are returned.
1	PF1DDR	0	W	
0	PF0DDR	0	W	

8.15.2 Port F Output Data Register (PFODR)

PFODR stores output data for the port F pins.

Bit	Bit Name	Initial Value	R/W	Description
7 to 3	—	—	—	Reserved. When this bit is read, an undefined value is returned.
2	PF2ODR	0	R/W	The PFODR register stores the output data for the pins that are used a general output port.
1	PF1ODR	0	R/W	
0	PF0ODR	0	R/W	

8.15.3 Port F Input Data Register (PFPIN)

PFPIN indicates the pin states of port F.

Bit	Bit Name	Initial Value	R/W	Description
7 to 3	—	—	—	Reserved. When this bit is read, an undefined value is returned.
2	PF2PIN	Undefined*	R	When PFPIN is read, the pin states are returned.
1	PF1PIN	Undefined*	R	This register is assigned to the same address as that of PFDDR. When this register is written to, data is written to PFDDR and the port F setting is then changed.
0	PF0PIN	Undefined*	R	

Note: The initial value of these pins is determined in accordance with the state of pins PF2 to PF0.

8.15.4 Pin Functions

Port F is a 3-bit input/output port that functions as a PWM output. The relationship between the register settings and pin functions is depicted below.

- PF2/ExPW2, PF1/ExPW1, PF0/ExPW0

The pin function is switched as shown below according to the combination of the OEn bit in PWOERA of PWM, the PWMS bit in PTCNT0, and PFnDDR bit.

PFnDDR	0		1		—
	0	1	0	1	
PWMS	0	1	0	1	1
OEn	—	0	—	0	1
Pin Function	PFn input pin		PFn output pin		PWn output pin

[Legend]

n = 2 to 0

8.16 Change of Peripheral Function Pins

I/O ports that also function as peripheral modules, such as the external interrupts, 8-bit timer input, and 8-bit PWM timer output, can be changed.

I/O ports that also function as the external interrupt pins are changed according to the setting of ISSR16 and ISSR. I/O ports that also function as the 8-bit timer input pins and the 8-bit PWM timer output pins are changed according to the setting of PTCNT0. The pin name of the peripheral function is indicated by adding 'Ex' at the head of the original pin name. In each peripheral function description, the original pin name is used.

8.16.1 IRQ Sense Port Select Register 16 (ISSR16), IRQ Sense Port Select Register (ISSR)

ISSR16 and ISSR select ports that also function as $\overline{\text{IRQ15}}$ to $\overline{\text{IRQ0}}$ input pins.

- ISSR16

Bit	Bit Name	Initial Value	R/W	Description
15	ISS15	0	R/W	0: P57/ $\overline{\text{IRQ15}}$ is selected 1: P87/ $\overline{\text{ExIRQ15}}$ is selected
14	ISS14	0	R/W	0: P56/ $\overline{\text{IRQ14}}$ is selected 1: P86/ $\overline{\text{ExIRQ14}}$ is selected
13	ISS13	0	R/W	0: P55/ $\overline{\text{IRQ13}}$ is selected 1: P85/ $\overline{\text{ExIRQ13}}$ is selected
12	ISS12	0	R/W	0: P54/ $\overline{\text{IRQ12}}$ is selected 1: P84/ $\overline{\text{ExIRQ12}}$ is selected
11	ISS11	0	R/W	0: P53/ $\overline{\text{IRQ11}}$ is selected 1: P83/ $\overline{\text{ExIRQ11}}$ is selected
10	ISS10	0	R/W	0: P52/ $\overline{\text{IRQ10}}$ is selected 1: P82/ $\overline{\text{ExIRQ10}}$ is selected
9	ISS9	0	R/W	0: P51/ $\overline{\text{IRQ9}}$ is selected 1: P81/ $\overline{\text{ExIRQ9}}$ is selected
8	ISS8	0	R/W	0: P50/ $\overline{\text{IRQ8}}$ is selected 1: P80/ $\overline{\text{ExIRQ8}}$ is selected

- ISSR

Bit	Bit Name	Initial Value	R/W	Description
7	ISS7	0	R/W	0: P47/ $\overline{\text{IRQ7}}$ is selected 1: P77/ $\overline{\text{ExIRQ7}}$ is selected
6	ISS6	0	R/W	0: P46/ $\overline{\text{IRQ6}}$ is selected 1: P76/ $\overline{\text{ExIRQ6}}$ is selected
5	ISS5	0	R/W	0: P45/ $\overline{\text{IRQ5}}$ is selected 1: P75/ $\overline{\text{ExIRQ5}}$ is selected
4	ISS4	0	R/W	0: P44/ $\overline{\text{IRQ4}}$ is selected 1: P74/ $\overline{\text{ExIRQ4}}$ is selected
3	ISS3	0	R/W	0: P43/ $\overline{\text{IRQ3}}$ is selected 1: P73/ $\overline{\text{ExIRQ3}}$ is selected
2	ISS2	0	R/W	0: P42/ $\overline{\text{IRQ2}}$ is selected 1: P72/ $\overline{\text{ExIRQ2}}$ is selected
1	ISS1	0	R/W	P41/ $\overline{\text{IRQ1}}$ is always selected
0	ISS0	0	R/W	P40/ $\overline{\text{IRQ0}}$ is always selected

8.16.2 Port Control Register 0 (PTCNT0)

PTCNT0 selects ports that also function as 8-bit timer input pins, and 8-bit PWM timer output pins.

Bit	Bit Name	Initial Value	R/W	Description
7	TMI0S	0	R/W	0: P40/TMI0 is selected 1: P84/ExTMI0 is selected
6	TMI1S	0	R/W	0: P41/TMI1 is selected 1: P85/ExTMI1 is selected
5	TMIXS	0	R/W	0: P44/TMIX is selected 1: P86/ExTMIX is selected
4	TMIYS	0	R/W	0: P45/TMIY is selected 1: P87/ExTMIY is selected
3	—	0	R/W	Reserved The initial values should not be changed.
2	PWMS	0	R/W	0: P10/PW0, P11/PW1, P12/PW2 are selected 1: PF0/ExPW0, PF1/ExPW1, and PF2/ExPW2 are selected
1, 0	—	All 0	R/W	Reserved The initial values should not be changed.

Section 9 8-Bit PWM Timer (PWM)

This LSI has an on-chip pulse width modulation (PWM) timer with sixteen outputs. Sixteen output waveforms are generated from a common time base, enabling PWM output with a high carrier frequency to be produced using pulse division.

9.1 Features

- Operable at a maximum carrier frequency of 2.06 kHz using pulse division (at 33 MHz operation)
- Duty cycles from 0 to 100% with 1/256 resolution (100% duty realized by port output)
- Direct or inverted PWM output, and PWM output enable/disable control

Figure 9.1 shows a block diagram of the PWM timer.

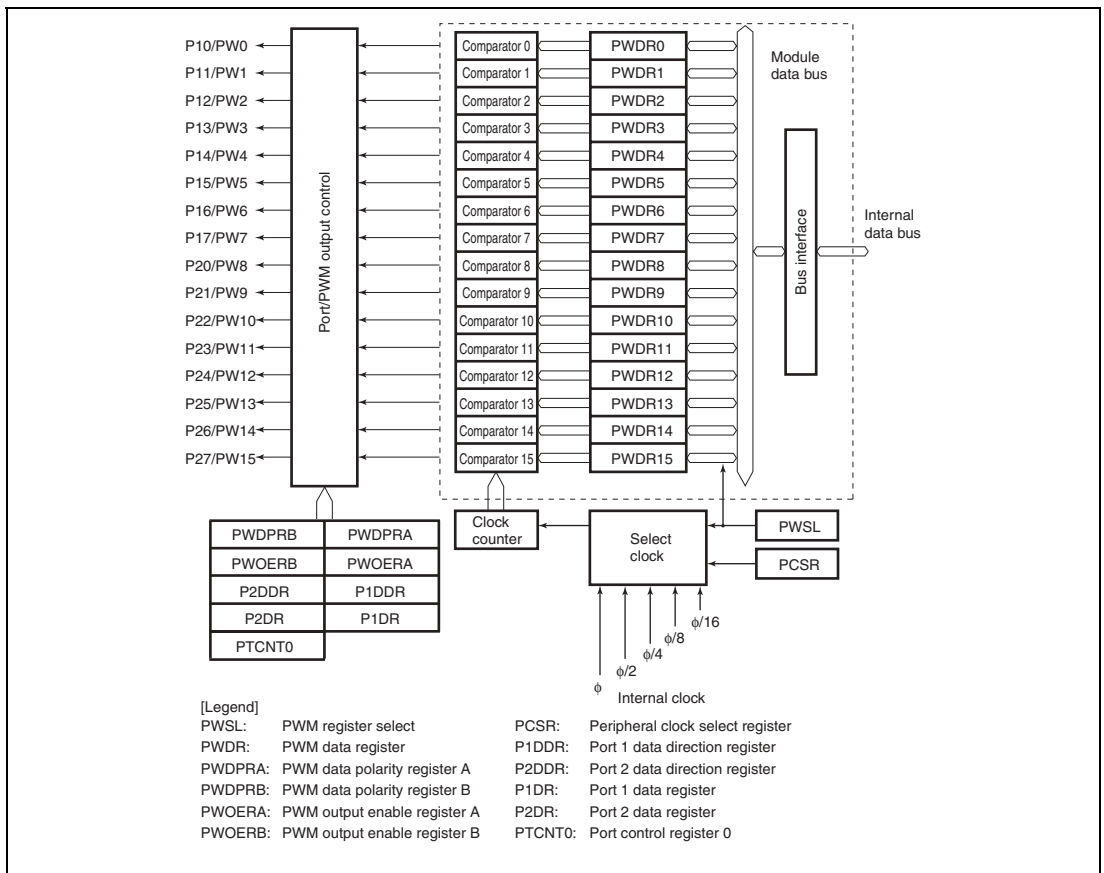

Figure 9.1 Block Diagram of PWM Timer

9.2 Input/Output Pins

Table 9.1 shows the PWM output pins.

Table 9.1 Pin Configuration

Name	Abbreviation	I/O	Function
PWM output 15 to 0	PW15 to PW0	Output	PWM timer pulse output 15 to 0

9.3 Register Descriptions

The PWM has the following registers. To access PCSR, the FLSHE bit in the serial timer control register (STCR) must be cleared to 0. For details on the serial timer control register (STCR), see section 3.2.3, Serial Timer Control Register (STCR).

- PWM register select (PWSL)
- PWM data registers 15 to 0 (PWDR15 to PWDR0)
- PWM data polarity register A (PWDpra)
- PWM data polarity register B (PwDprB)
- PWM output enable register A (PWOERA)
- PWM output enable register B (PWOERB)
- Peripheral clock select register (PCSR)

9.3.1 PWM Register Select (PWSL)

PWSL is used to select the input clock and the PWM data register.

Bit	Bit Name	Initial Value	R/W	Description
7	PWCKE	0	R/W	PWM Clock Enable
6	PWCKS	0		PWM Clock Select
				These bits, together with bits PWCKB and PWCKA in PCSR, select the internal clock input to TCNT in the PWM. For details, see table 9.2.
				The resolution, PWM conversion period, and carrier frequency depend on the selected internal clock, and can be obtained from the following equations.
				Resolution (minimum pulse width) = 1/internal clock frequency
				PWM conversion period = resolution × 256
				Carrier frequency = 16/PWM conversion period
				With a 33 MHz system clock (ϕ), the resolution, PWM conversion period, and carrier frequency are as shown in table 9.3.
5	—	1	R	Reserved
				This bit is always read as 1 and cannot be modified.
4	—	0	R	Reserved
				This bit is always read as 0 and cannot be modified.

Bit	Bit Name	Initial Value	R/W	Description
3 to 0	RS3 to RS0	All 0	R/W	Register Select
				These bits select the PWM data register.
				0000: PWDR0 selected
				0001: PWDR1 selected
				0010: PWDR2 selected
				0011: PWDR3 selected
				0100: PWDR4 selected
				0101: PWDR5 selected
				0110: PWDR6 selected
				0111: PWDR7 selected
				1000: PWDR8 selected
				1001: PWDR9 selected
				1010: PWDR10 selected
				1011: PWDR11 selected
				1100: PWDR12 selected
				1101: PWDR13 selected
				1110: PWDR14 selected
				1111: PWDR15 selected

Table 9.2 Internal Clock Selection

PWSL		PCSR		Description	
PWCKE	PWCKS	PWCKB	PWCKA		
0	—	—	—	Clock input is disabled (Initial value)	
1	0	—	—	ϕ (system clock) is selected	
			1	0	$\phi/2$ is selected
			1	$\phi/4$ is selected	
			1	0	$\phi/8$ is selected
				1	$\phi/16$ is selected

Table 9.3 Resolution, PWM Conversion Period, and Carrier Frequency when $\phi = 33$ MHz

Internal Clock Frequency	Resolution	PWM Conversion Period	Carrier Frequency
ϕ	30 ns	7.76 μ s	2063 kHz
$\phi/2$	61 ns	15.52 μ s	1031 kHz
$\phi/4$	121 ns	31.03 μ s	515.6 kHz
$\phi/8$	242 ns	62.06 μ s	257.8 kHz
$\phi/16$	485 ns	124.12 μ s	128.9 kHz

9.3.2 PWM Data Registers 15 to 0 (PWDR15 to PWDR0)

PWDR are 8-bit readable/writable registers. The PWM has sixteen PWM data registers. Each PWDR specifies the duty cycle of the basic pulse to be output, and the number of additional pulses. The value set in PWDR corresponds to a 0 or 1 ratio in the conversion period. The upper four bits specify the duty cycle of the basic pulse as 0/16 to 15/16 with a resolution of 1/16. The lower four bits specify how many extra pulses are to be added within the conversion period comprising 16 basic pulses. Thus, a specification of 0/256 to 255/256 is possible for 0/1 ratios within the conversion period. For 256/256 (100%) output, port output should be used.

9.3.3 PWM Data Polarity Registers A and B (PWARDRA and PWARDRB)

Each PWARDR selects the PWM output phase.

- PWARDRA

Bit	Bit Name	Initial Value	R/W	Description
7 to 0	OS7 to OS0	All 0	R/W	Output Select 7 to 0 These bits select the PWM output phase. Bits OS7 to OS0 correspond to outputs PW7 to PW0. 0: PWM direct output (PWDR value corresponds to high width of output) 1: PWM inverted output (PWDR value corresponds to low width of output)

- PWDPRB

Bit	Bit Name	Initial Value	R/W	Description
7 to 0	OS15 to OS8	All 0	R/W	Output Select 15 to 8 These bits select the PWM output phase. Bits OS15 to OS8 correspond to outputs PW15 to PW8. 0: PWM direct output (PWDR value corresponds to high width of output) 1: PWM inverted output (PWDR value corresponds to low width of output)

9.3.4 PWM Output Enable Registers A and B (PWOERA and PWOERB)

Each PWOER switches between PWM output and port output.

- PWOERA

Bit	Bit Name	Initial Value	R/W	Description
7 to 0	OE7 to OE0	All 0	R/W	Output Enable 7 to 0 These bits, together with P1DDR, specify the P1n/PWn pin state. Bits OE7 to OE0 correspond to outputs PW7 to PW0. P1nDDR OEn: Pin state 0*: Port input 10: Port output or PWM 256/256 output 11: PWM output (0 to 255/256 output)

[Legend]

n = 0 to 7

*: Don't care

- PWOERB

Bit	Bit Name	Initial Value	R/W	Description
7 to 0	OE15 to OE8	All 0	R/W	Output Enable 15 to 8 These bits, together with P2DDR, specify the P2n/PWm pin state. Bits OE15 to OE8 correspond to outputs PW15 to PW8. P2nDDR OEM: Pin state 0*: Port input 10: Port output or PWM 256/256 output 11: PWM output (0 to 255/256 output)

[Legend]

n = 0 to 7

m = 8 to 15

*: Don't care

To perform PWM 256/256 output when DDR = 1 and OE = 0, the corresponding pin should be set to port output. The corresponding pin can be set as port output in single-chip mode or when IOSE = 1 and CS256E = 0 in SYSCR in extended mode with on-chip ROM. Otherwise, it should be noted that an address bus is output to the corresponding pin.

DR data is output when the corresponding pin is used as port output. A value corresponding to PWM 256/256 output is determined by the OS bit, so the value should have been set to DR beforehand.

9.3.5 Peripheral Clock Select Register (PCSR)

PCSR selects the PWM input clock.

Bit	Bit Name	Initial Value	R/W	Description
7	PWCKX1B	0	R/W	See section 10.3.4, Peripheral Clock Select Register (PCSR).
6	PWCKX1A	0	R/W	
5	PWCKX0B	0	R/W	
4	PWCKX0A	0	R/W	
3	PWCKX1C	0	R/W	
2	PWCKB	0	R/W	PWM Clock Select B and A Together with bits PWCKE and PWCKS in PWSL, these bits select the internal clock input to TCNT in the PWM. For details, see table 9.2.
1	PWCKA	0	R/W	
0	PWCKX0C	0	R/W	See section 10.3.4, Peripheral Clock Select Register (PCSR).

9.4 Operation

The upper four bits of PWDR specify the duty cycle of the basic pulse as 0/16 to 15/16 with a resolution of 1/16. Table 9.4 shows the duty cycles of the basic pulse.

Table 9.4 Duty Cycle of Basic Pulse

Upper 4 Bits	Basic Pulse Waveform (Internal)
B'0000	H: 0 1 2 3 4 5 6 7 8 9 A B C D E F 0 L: _____
B'0001	
B'0010	
B'0011	
B'0100	
B'0101	
B'0110	
B'0111	
B'1000	
B'1001	
B'1010	
B'1011	
B'1100	
B'1101	
B'1110	
B'1111	

The lower four bits of PWDR specify the position of pulses added to the 16 basic pulses. An additional pulse adds a high period (when OS = 0) with a width equal to the resolution before the rising edge of a basic pulse. When the upper four bits of PWDR are B'0000, there is no rising edge of the basic pulse, but the timing for adding pulses is the same. Table 9.5 shows the positions of the additional pulses added to the basic pulses, and figure 9.2 shows an example of additional pulse timing.

Table 9.5 Position of Pulses Added to Basic Pulses

Lower 4 Bits	Basic Pulse No.															
	0	1	2	3	4	5	6	7	8	9	10	11	12	13	14	15
B'0000																
B'0001																Yes
B'0010								Yes								Yes
B'0011								Yes			Yes					Yes
B'0100				Yes				Yes			Yes					Yes
B'0101				Yes				Yes			Yes	Yes				Yes
B'0110				Yes	Yes			Yes			Yes	Yes				Yes
B'0111				Yes	Yes	Yes		Yes	Yes		Yes	Yes	Yes			Yes
B'1000	Yes	Yes	Yes	Yes	Yes	Yes	Yes	Yes	Yes	Yes	Yes	Yes	Yes	Yes	Yes	Yes
B'1001	Yes	Yes	Yes	Yes	Yes	Yes	Yes	Yes	Yes	Yes	Yes	Yes	Yes	Yes	Yes	Yes
B'1010	Yes	Yes	Yes	Yes	Yes	Yes	Yes	Yes	Yes	Yes	Yes	Yes	Yes	Yes	Yes	Yes
B'1011	Yes	Yes	Yes	Yes	Yes	Yes	Yes	Yes	Yes	Yes	Yes	Yes	Yes	Yes	Yes	Yes
B'1100	Yes	Yes	Yes	Yes	Yes	Yes	Yes	Yes	Yes	Yes	Yes	Yes	Yes	Yes	Yes	Yes
B'1101	Yes	Yes	Yes	Yes	Yes	Yes	Yes	Yes	Yes	Yes	Yes	Yes	Yes	Yes	Yes	Yes
B'1110	Yes	Yes	Yes	Yes	Yes	Yes	Yes	Yes	Yes	Yes	Yes	Yes	Yes	Yes	Yes	Yes
B'1111	Yes	Yes	Yes	Yes	Yes	Yes	Yes	Yes	Yes	Yes	Yes	Yes	Yes	Yes	Yes	Yes

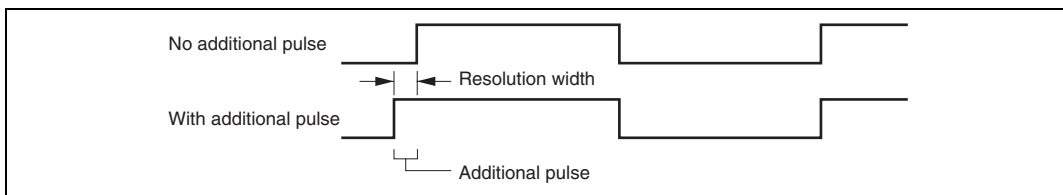

Figure 9.2 Example of Additional Pulse Timing (When Upper 4 Bits of PWDR = B'1000)

9.4.1 PWM Setting Example

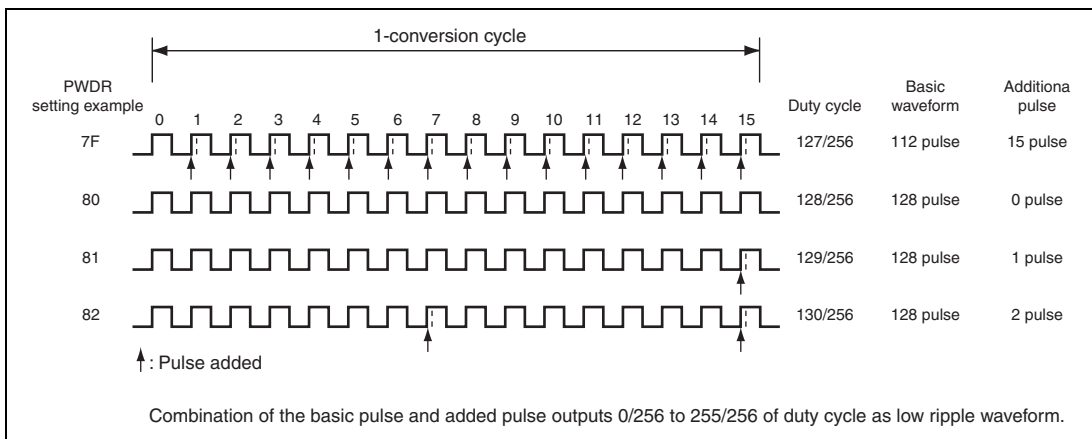

Figure 9.3 Example of PWM Setting

9.4.2 Diagram of PWM Used as D/A Converter

Figure 9.4 shows the diagram example when using the PWM pulse as the D/A converter. Analog signal with low ripple can be generated by connecting the low pass filter.

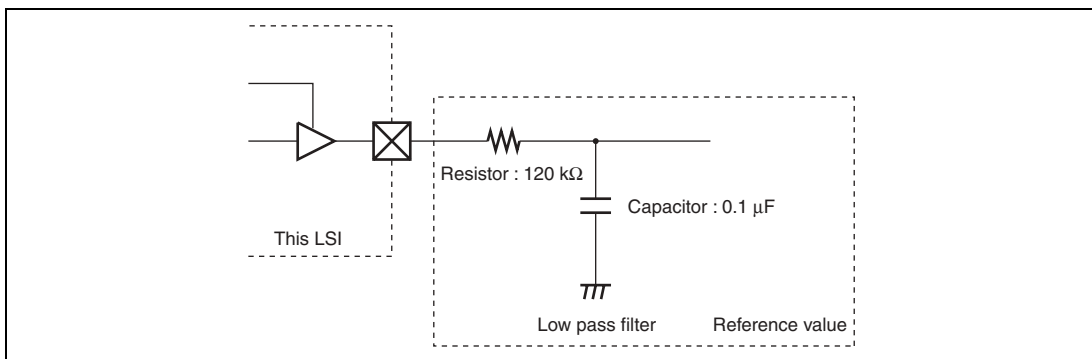

Figure 9.4 Example when PWM is Used as D/A Converter

Section 10 14-Bit PWM Timer (PWMX)

This LSI has an on-chip 14-bit pulse-width modulator (PWM) timer with four output channels. It can be connected to an external low-pass filter to operate as a 14-bit D/A converter.

10.1 Features

- Division of pulse into multiple base cycles to reduce ripple
- Eight resolution settings
The resolution can be set to 1, 2, 64, 128, 256, 1024, 4096, or 16384 system clock cycles.
- Two base cycle settings
The base cycle can be set equal to $T \times 64$ or $T \times 256$, where T is the resolution.
- Sixteen operation clocks (by combination of eight resolution settings and two base cycle settings)

Figure 10.1 shows a block diagram of the PWM (D/A) module.

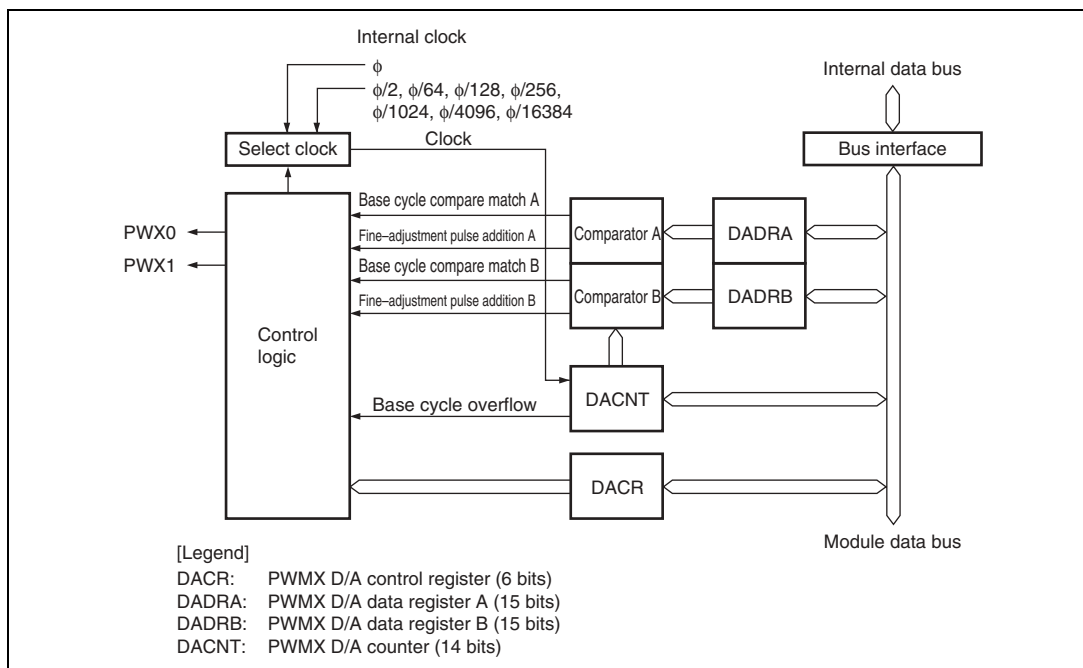

Figure 10.1 PWMX (D/A) Block Diagram

10.2 Input/Output Pins

Table 10.1 lists the PWMX (D/A) module input and output pins.

Table 10.1 Pin Configuration

Name	Abbreviation	I/O	Function
PWMX output pin 0	PWX0	Output	PWM timer pulse output of PWMX_0 channel A
PWMX output pin 1	PWX1	Output	PWM timer pulse output of PWMX_0 channel B
PWMX output pin 2	PWX2	Output	PWM timer pulse output of PWMX_1 channel A
PWMX output pin 3	PWX3	Output	PWM timer pulse output of PWMX_1 channel B

10.3 Register Descriptions

The PWMX (D/A) module has the following registers. The PWMX (D/A) registers are assigned to the same addresses with other registers. The registers are selected by the IICE bit in the serial timer control register (STCR). For details on the module stop control register, see section 23.1.3, Module Stop Control Register H, L, and A (MSTPCRH, MSTPCRL, MSTPCRA).

- PWMX (D/A) counter (DACNT)
- PWMX (D/A) data register A (DADRA)
- PWMX (D/A) data register B (DADRB)
- PWMX (D/A) control register (DACR)
- Peripheral clock select register (PCSR)

Note: The same addresses are shared by DADRA and DACR, and by DADRB and DACNT. Switching is performed by the REGS bit in DACNT or DADRB.

10.3.1 PWMX (D/A) Counter (DACNT)

DACNT is a 14-bit readable/writable up-counter. The input clock is selected by the clock select bit (CKS) in DACR. DACNT functions as the time base for both PWMX (D/A) channels. When a channel operates with 14-bit precision, it uses all DACNT bits. When a channel operates with 12-bit precision, it uses the lower 12 bits and ignores the upper two bits. DACNT cannot be accessed in 8-bit units. DACNT should always be accessed in 16-bit units. For details, see section 10.4, Bus Master Interface.

- DACNT

Bit	Bit Name	Initial Value	R/W	Description
15 to 8	UC7 to UC0	All 0	R/W	Lower Up-Counter
7 to 2	UC8 to UC13	All 0	R/W	Upper Up-Counter
1	—	1	R	Reserved This bit is always read as 1 and cannot be modified.
0	REGS	1	R/W	Register Select DADRA and DACR, and DADRB and DACNT, are located at the same addresses. The REGS bit specifies which registers can be accessed. When changing the register to be accessed, set this bit in advance. 0: DADRA and DADRB can be accessed 1: DACR and DACNT can be accessed

10.3.2 PWMX (D/A) Data Registers A and B (DADRA and DADRB)

DADRA corresponds to PWMX (D/A) channel A, and DADRB to PWMX (D/A) channel B. The DADR registers cannot be accessed in 8-bit units. The DADR registers should always be accessed in 16-bit units. For details, see section 10.4, Bus Master Interface.

- DADRA

Bit	Bit Name	Initial Value	R/W	Description
15 to 2	DA13 to DA0	All 1	R/W	D/A Data 13 to 0 These bits set a digital value to be converted to an analog value. In each base cycle, the DACNT value is continually compared with the DADR value to determine the duty cycle of the output waveform, and to decide whether to output a fine-adjustment pulse equal in width to the resolution. To enable this operation, this register must be set within a range that depends on the CFS bit. If the DADR value is outside this range, the PWM output is held constant. A channel can be operated with 12-bit precision by fixing DA0 and DA1 to 0. The two data bits are not compared with UC12 and UC13 of DACNT.
1	CFS	1	R/W	Carrier Frequency Select 0: Base cycle = resolution (T) × 64 The range of DA13 to DA0: H'0100 to H'3FFF 1: Base cycle = resolution (T) × 256 The range of DA13 to DA0: H'0040 to H'3FFF
0	—	1	R	Reserved This bit is always read as 1 and cannot be modified.

- DADRB

Bit	Bit Name	Initial Value	R/W	Description
15 to 2	DA13 to DA0	All 1	R/W	<p>D/A Data 13 to 0</p> <p>These bits set a digital value to be converted to an analog value.</p> <p>In each base cycle, the DACNT value is continually compared with the DADR value to determine the duty cycle of the output waveform, and to decide whether to output a fine-adjustment pulse equal in width to the resolution. To enable this operation, this register must be set within a range that depends on the CFS bit. If the DADR value is outside this range, the PWM output is held constant.</p> <p>A channel can be operated with 12-bit precision by fixing DA0 and DA1 to 0. The two data bits are not compared with UC12 and UC13 of DACNT.</p>
1	CFS	1	R/W	<p>Carrier Frequency Select</p> <p>0: Base cycle = resolution (T) × 64 DA13 to DA0 range = H'0100 to H'3FFF</p> <p>1: Base cycle = resolution (T) × 256 DA13 to DA0 range = H'0040 to H'3FFF</p>
0	REGS	1	R/W	<p>Register Select</p> <p>DADRA and DACR, and DADRB and DACNT, are located at the same addresses. The REGS bit specifies which registers can be accessed. When changing the register to be accessed, set this bit in advance.</p> <p>0: DADRA and DADRB can be accessed</p> <p>1: DACR and DACNT can be accessed</p>

10.3.3 PWMX (D/A) Control Register (DACR)

DACR enables the PWM outputs, and selects the output phase and operating speed.

Bit	Bit Name	Initial Value	R/W	Description
7	—	0	R/W	Reserved The initial value should not be changed.
6	PWME	0	R/W	PWMX Enable Starts or stops the PWM D/A counter (DACNT). 0: DACNT operates as a 14-bit up-counter 1: DACNT halts at H'0003
5, 4	—	All 1	R	Reserved These bits are always read as 1 and cannot be modified.
3	OEB	0	R/W	Output Enable B Enables or disables output on PWMX (D/A) channel B. 0: PWMX (D/A) channel B output (at the PWX1, PWX3 pins) is disabled 1: PWMX (D/A) channel B output (at the PWX1, PWX3 pins) is enabled
2	OEA	0	R/W	Output Enable A Enables or disables output on PWMX (D/A) channel A. 0: PWMX (D/A) channel A output (at the PWX0, PWX2 pin) is disabled 1: PWMX (D/A) channel A output (at the PWX0, PWX2 pins) is enabled
1	OS	0	R/W	Output Select Selects the phase of the PWMX (D/A) output. 0: Direct PWMX (D/A) output 1: Inverted PWMX (D/A) output
0	CKS	0	R/W	Clock Select Selects the PWMX (D/A) resolution. Eight kinds of resolution can be selected. 0: Operates at resolution (T) = system clock cycle time (t_{cyc}) 1: Operates at resolution (T) = system clock cycle time (t_{cyc}) × 2, × 64, × 128, × 256, × 1024, × 4096, and × 16384.

10.3.4 Peripheral Clock Select Register (PCSR)

PCSR and the CKS bit of DACR select the operating speed.

Bit	Bit Name	Initial Value	R/W	Description
7	PWCKX1B	0	R/W	PWMX_1 Clock Select
6	PWCKX1A	0	R/W	These bits select a clock cycle with the CKS bit of DACR of PWMX_1 being 1. See table 10.2.
5	PWCKX0B	0	R/W	PWMX_0 Clock Select
4	PWCKX0A	0	R/W	These bits select a clock cycle with the CKS bit of DACR of PWMX_0 being 1. See table 10.2.
3	PWCKX1C	0	R/W	PWMX_1 Clock Select This bit selects a clock cycle with the CKS bit of DACR of PWMX_1 being 1. See table 10.2.
2	PWCKB	0	R/W	PWM Clock Select B and A
1	PWCKA	0	R/W	See section 9.3.5, Peripheral Clock Select Register (PCSR).
0	PWCKX0C	0	R/W	PWMX_0 Clock Select This bit selects a clock cycle with the CKS bit of DACR of PWMX_0 being 1. See table 10.2.

Table 10.2 Clock Select of PWMX_1 and PWMX_0

PWCKX0C PWCKX1C	PWCKX0B PWCKX1B	PWCKX0A PWCKX1A	Resolution (T)
0	0	0	Operates on the system clock cycle (t_{cyc}) x 2
0	0	1	Operates on the system clock cycle (t_{cyc}) x 64
0	1	0	Operates on the system clock cycle (t_{cyc}) x 128
0	1	1	Operates on the system clock cycle (t_{cyc}) x 256
1	0	0	Operates on the system clock cycle (t_{cyc}) x 1024
1	0	1	Operates on the system clock cycle (t_{cyc}) x 4096
1	1	0	Operates on the system clock cycle (t_{cyc}) x 16384
1	1	1	Setting prohibited

10.4 Bus Master Interface

DACNT, DADRA, and DADRB are 16-bit registers. The data bus linking the bus master and the on-chip peripheral modules, however, is only 8 bits wide. When the bus master accesses these registers, it therefore uses an 8-bit temporary register (TEMP).

These registers are written to and read from as follows.

- **Write**
When the upper byte is written to, the upper-byte write data is stored in TEMP. Next, when the lower byte is written to, the lower-byte write data and TEMP value are combined, and the combined 16-bit value is written in the register.
- **Read**
When the upper byte is read from, the upper-byte value is transferred to the CPU and the lower-byte value is transferred to TEMP. Next, when the lower byte is read from, the lower-byte value in TEMP is transferred to the CPU.

These registers should always be accessed 16 bits at a time with a MOV instruction, and the upper byte should always be accessed before the lower byte. Correct data will not be transferred if only the upper byte or only the lower byte is accessed. Also note that a bit manipulation instruction cannot be used to access these registers.

Example 1: Write to DACNT

```
MOV.W R0, @DACNT ; Write R0 contents to DACNT
```

Example 2: Read DADRA

```
MOV.W @DADRA, R0 ; Copy contents of DADRA to R0
```

10.5 Operation

A PWM waveform like the one shown in figure 10.2 is output from the PWX pin. DA13 to DA0 in DADR corresponds to the total width (T_L) of the low (0) pulses output in one conversion cycle (256 pulses when CFS = 0, 64 pulses when CFS = 1). When OS = 0, this waveform is directly output. When OS = 1, the output waveform is inverted, and DA13 to DA0 in DADR value corresponds to the total width (T_H) of the high (1) output pulses. Figures 10.3 and 10.4 show the types of waveform output available.

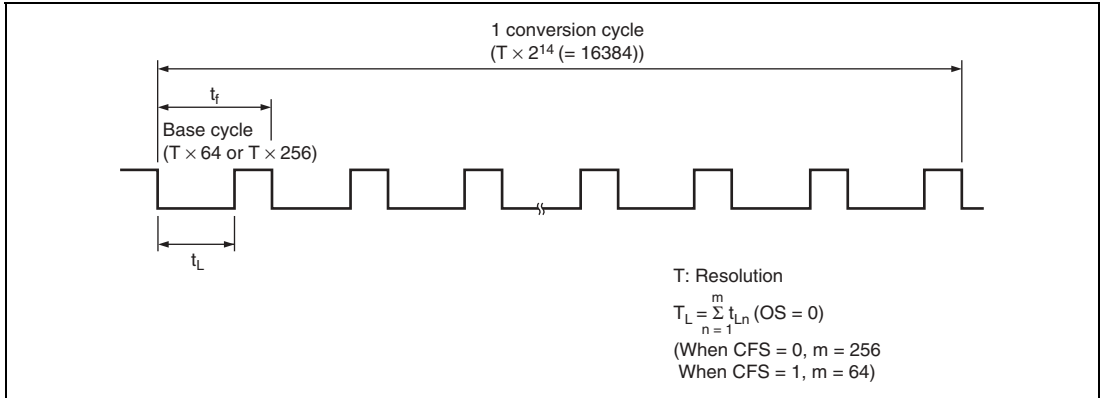

Figure 10.2 PWMX (D/A) Operation

Table 10.3 summarizes the relationships between the CKS and CFS bit settings and the resolution, base cycle, and conversion cycle. The PWM output remains fixed unless DA13 to DA0 in DADR contain at least a certain minimum value. The relationship between the OS bit and the output waveform is shown in figures 10.3 and 10.4.

Table 10.3 Settings and Operation (Examples when $\phi = 33$ MHz)

PCSR					Fixed DADR Bits									
PWCKX0 PWCKX1			Reso- lution T (μ s)	Base CFS Cycle	Conver- sion Cycle	TL/TH (OS = 0/OS = 1)	Accuracy (Bits)	Bit Data				Conversion Cycle (ms)*		
C	B	A						CKS	DA3	DA2	DA1		DA0	
—	—	—	0	0.03	0	1.94 (μ s)	496.48 (μ s)	Always low/high output DA13 to 0 = H'0000 to H'00FF (Data value) \times T	14					0.50
								DA13 to 0 = H'0100 to H'3FFF	12		0	0		0.12
									10	0	0	0	0	0.03
					1	7.76 (μ s)	496.48 (μ s)	Always low/high output DA13 to 0 = H'0000 to H'003F (Data value) \times T	14					0.50
								DA13 to 0 = H'0040 to H'3FFF	12		0	0		0.12
			(ϕ)			/128.9kHz			10	0	0	0	0	0.03
0	0	0	1	0.06	0	3.88 (μ s)	0.99 (ms)	Always low/high output DA13 to 0 = H'0000 to H'00FF (Data value) \times T	14					0.99
								DA13 to 0 = H'0100 to H'3FFF	12		0	0		0.25
									10	0	0	0	0	0.06
					1	15.52 (μ s)	0.99 (ms)	Always low/high output DA13 to 0 = H'0000 to H'003F (Data value) \times T	14					0.99
								DA13 to 0 = H'0040 to H'3FFF	12		0	0		0.25
			($\phi/2$)			/64.5kHz			10	0	0	0	0	0.06
0	0	1	1	1.94	0	124.12 (μ s)	31.78 (ms)	Always low/high output DA13 to 0 = H'0000 to H'00FF (Data value) \times T	14					31.78
								DA13 to 0 = H'0100 to H'3FFF	12		0	0		7.94
									10	0	0	0	0	1.99
					1	496.48 (μ s)	31.78 (ms)	Always low/high output DA13 to 0 = H'0000 to H'003F (Data value) \times T	14					31.78
								DA13 to 0 = H'0040 to H'3FFF	12		0	0		7.94
			($\phi/64$)			/2.0kHz			10	0	0	0	0	1.99
0	1	0	1	3.88	0	248.24 (μ s)	63.55 (ms)	Always low/high output DA13 to 0 = H'0000 to H'00FF (Data value) \times T	14					63.55
								DA13 to 0 = H'0100 to H'3FFF	12		0	0		15.89
									10	0	0	0	0	3.97
					1	992.97 (μ s)	63.55 (ms)	Always low/high output DA13 to 0 = H'0000 to H'003F (Data value) \times T	14					63.55
								DA13 to 0 = H'0040 to H'3FFF	12		0	0		15.89
			($\phi/128$)			/1.0kHz			10	0	0	0	0	3.97

PCSR				Fixed DADR Bits										
PWCKX0 PWCKX1				Reso- lution T (μ s)	Base		Conver- sion Cycle	TL/TH (OS = 0/OS = 1)	Accuracy (Bits)	Bit Data				Conversion Cycle (ms)*
C	B	A	CKS		CFS	Cycle				DA3	DA2	DA1	DA0	
0	1	1	1	7.76	0	496.48	127.10	Always low/high output	14					127.10
						(μ s)	(ms)	DA13 to 0 = H'0000 to H'00FF (Data value) \times T	12		0	0	31.78	
						/2.0kHz	DA13 to 0 = H'0100 to H'3FFF	10	0	0	0	0	7.94	
					1	1985.94	127.10	Always low/high output	14				127.10	
						(μ s)	(ms)	DA13 to 0 = H'0000 to H'003F (Data value) \times T	12		0	0	31.78	
						(ϕ /256)	/0.5kHz	DA13 to 0 = H'0040 to H'3FFF	10	0	0	0	0	7.94
1	0	0	1	31.03	0	1.99	508.40	Always low/high output	14				508.40	
						(ms)	(ms)	DA13 to 0 = H'0000 to H'00FF (Data value) \times T	12		0	0	127.10	
						/503.5Hz	DA13 to 0 = H'0100 to H'3FFF	10	0	0	0	0	31.78	
					1	7.94	508.40	Always low/high output	14				508.40	
						(ms)	(ms)	DA13 to 0 = H'0000 to H'003F (Data value) \times T	12		0	0	127.10	
						(ϕ /1024)	/125.9Hz	DA13 to 0 = H'0040 to H'3FFF	10	0	0	0	0	31.78
1	0	1	1	124.12	0	7.94	2.03	Always low/high output	14				2033.60	
						(ms)	(s)	DA13 to 0 = H'0000 to H'00FF (Data value) \times T	12		0	0	508.40	
						/125.9Hz	DA13 to 0 = H'0100 to H'3FFF	10	0	0	0	0	127.10	
					1	31.78	2.03	Always low/high output	14				2033.60	
						(ms)	(s)	DA13 to 0 = H'0000 to H'003F (Data value) \times T	12		0	0	508.40	
						(ϕ /4096)	/31.5Hz	DA13 to 0 = H'0040 to H'3FFF	10	0	0	0	0	127.10
1	1	0	1	496.48	0	31.78	8.13	Always low/high output	14				8134.41	
						(ms)	(s)	DA13 to 0 = H'0000 to H'00FF (Data value) \times T	12		0	0	2033.60	
						/31.5Hz	DA13 to 0 = H'0100 to H'3FFF	10	0	0	0	0	508.40	
					1	127.10	8.13	Always low/high output	14				8134.41	
						(ms)	(s)	DA13 to 0 = H'0000 to H'003F (Data value) \times T	12		0	0	2033.60	
						(ϕ /16384)	/7.9Hz	DA13 to 0 = H'0040 to H'3FFF	10	0	0	0	0	508.40
1	1	1	1	Setting prohibited	—	—	—	—	—	—	—	—	—	

Note: * Indicates the conversion cycle when specific DA3 to DA0 bits are fixed.

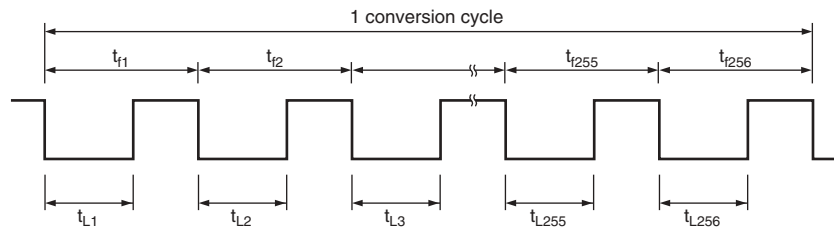

$$t_{f1} = t_{f2} = t_{f3} = \dots = t_{f255} = t_{f256} = T \times 64$$

$$t_{L1} + t_{L2} + t_{L3} + \dots + t_{L255} + t_{L256} = T_L$$

a. CFS = 0 [base cycle = resolution (T) × 64]

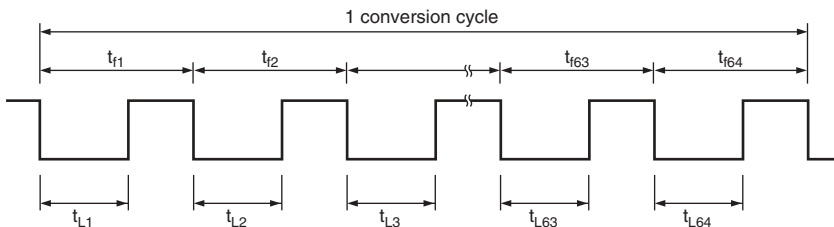

$$t_{f1} = t_{f2} = t_{f3} = \dots = t_{f63} = t_{f64} = T \times 256$$

$$t_{L1} + t_{L2} + t_{L3} + \dots + t_{L63} + t_{L64} = T_L$$

b. CFS = 1 [base cycle = resolution (T) × 256]

Figure 10.3 Output Waveform (OS = 0, DADR corresponds to T_L)

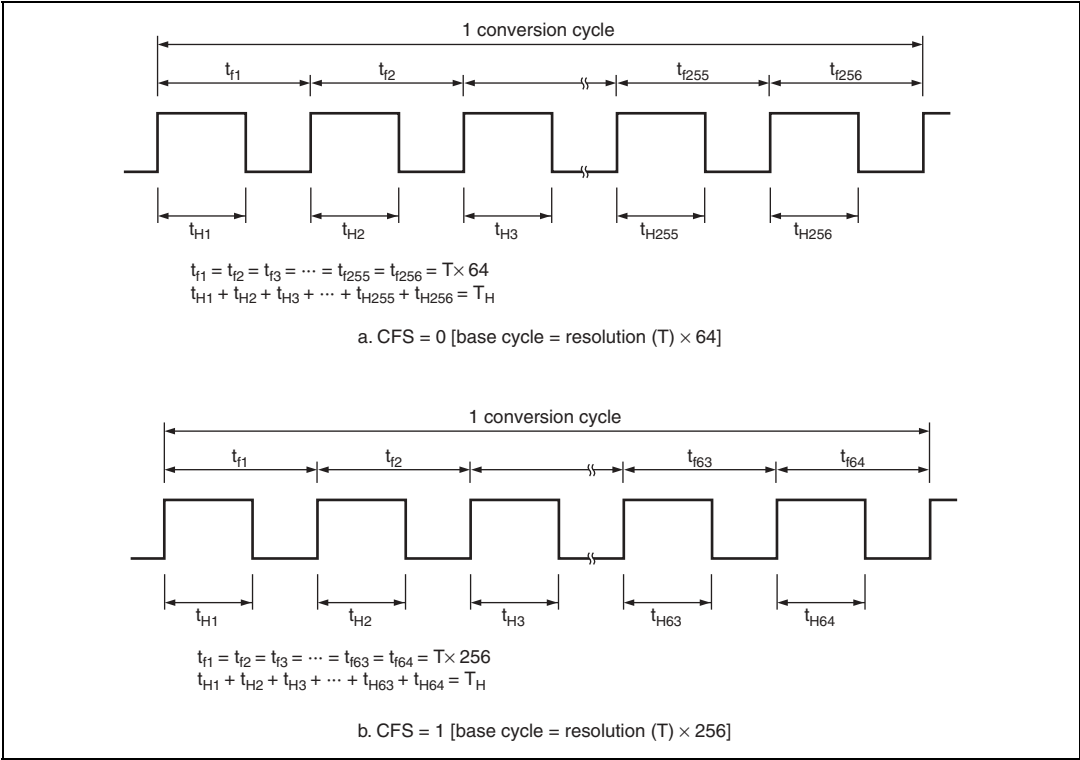

Figure 10.4 Output Waveform (OS = 1, DADR corresponds to T_H)

An example of the additional pulses when CFS = 1 (base cycle = resolution (T) × 256) and OS = 1 (inverted PWM output) is described below. When CFS = 1, the upper eight bits (DA13 to DA6) in DADR determine the duty cycle of the base pulse while the subsequent six bits (DA5 to DA0) determine the locations of the additional pulses as shown in figure 10.5.

Table 10.4 lists the locations of the additional pulses.

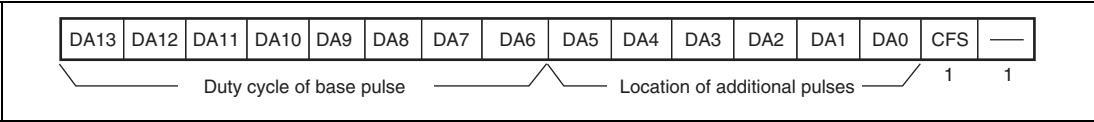

Figure 10.5 D/A Data Register Configuration when CFS = 1

In this example, DADR = H'0207 (B'0000 0010 0000 0111). The output waveform is shown in figure 10.6. Since CFS = 1 and the value of the upper eight bits is B'0000 0010, the high width of the base pulse duty cycle is $2/256 \times (T)$.

Since the value of the subsequent six bits is B'0000 01, an additional pulse is output only at the location of base pulse No. 63 according to table 10.4. Thus, an additional pulse of $1/256 \times (T)$ is to be added to the base pulse.

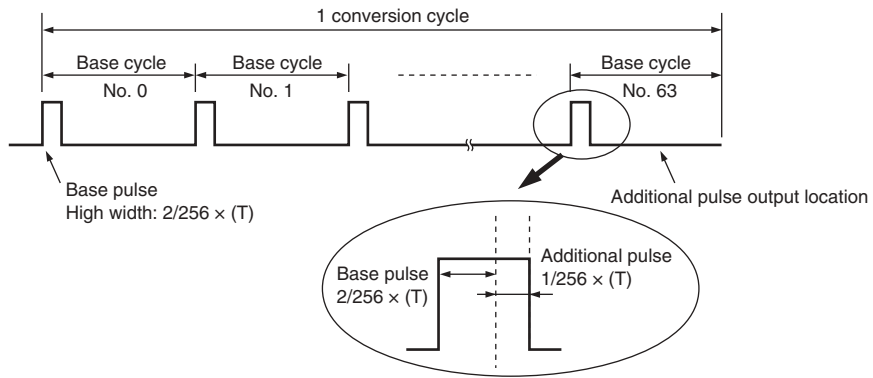

Figure 10.6 Output Waveform when DADR = H'0207 (OS = 1)

However, when CFS = 0 (base cycle = resolution $(T) \times 64$), the duty cycle of the base pulse is determined by the upper six bits and the locations of the additional pulses by the subsequent eight bits with a method similar to as above.

Section 11 16-Bit Free-Running Timer (FRT)

This LSI has an on-chip 16-bit free-running timer (FRT). The FRT operates on the basis of the 16-bit free-running counter (FRC), and outputs two independent waveforms, and measures the input pulse width and external clock periods.

11.1 Features

- Selection of four clock sources
 - One of the three internal clocks ($\phi/2$, $\phi/8$, or $\phi/32$), or an external clock input can be selected (enabling use as an external event counter).
- Two independent comparators
 - Two independent waveforms can be output.
- Four independent input capture channels
 - The rising or falling edge can be selected.
 - Buffer modes can be specified.
- Counter clearing
 - The free-running counters can be cleared on compare-match A.
- Seven independent interrupts
 - Two compare-match interrupts, four input capture interrupts, and one overflow interrupt can be requested independently.
- Special functions provided by automatic addition function
 - The contents of OCRAR and OCRAF can be added to the contents of OCRA automatically, enabling a periodic waveform to be generated without software intervention. The contents of ICRD can be added automatically to the contents of OCRDM $\times 2$, enabling input capture operations in this interval to be restricted.

Figure 11.1 shows a block diagram of the FRT.

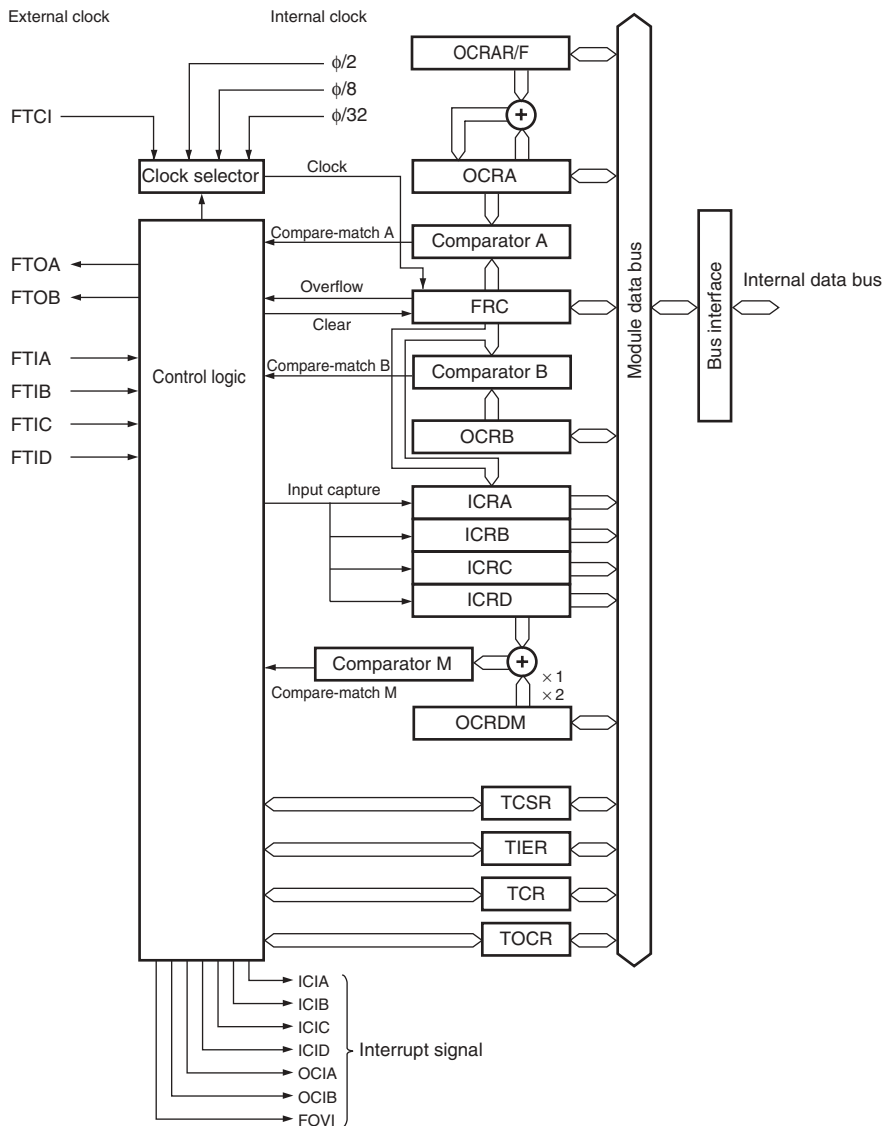

[Legend]

- OCRA, OCRB: Output compare register A, B (16-bit)
- OCRAR, OCRAF: Output compare register AR, AF (16-bit)
- OCRDM: Output compare register DM (16-bit)
- FRC: Free-running counter (16-bit)
- ICRA to D: Input capture registers A to D (16-bit)
- TCSR: Timer control/status register (8-bit)
- TIER: Timer interrupt enable register (8-bit)
- TCR: Timer control register (8-bit)
- TOCR: Timer output compare control register (8-bit)

Figure 11.1 Block Diagram of 16-Bit Free-Running Timer

11.2 Input/Output Pins

Table 11.1 lists the FRT input and output pins.

Table 11.1 Pin Configuration

Name	Abbreviation	I/O	Function
Counter clock input pin	FTCI	Input	FRC counter clock input
Output compare A output pin	FTOA	Output	Output compare A output
Output compare B output pin	FTOB	Output	Output compare B output
Input capture A input pin	FTIA	Input	Input capture A input
Input capture B input pin	FTIB	Input	Input capture B input
Input capture C input pin	FTIC	Input	Input capture C input
Input capture D input pin	FTID	Input	Input capture D input

11.3 Register Descriptions

The FRT has the following registers.

- Free-running counter (FRC)
- Output compare register A (OCRA)
- Output compare register B (OCRB)
- Input capture register A (ICRA)
- Input capture register B (ICRB)
- Input capture register C (ICRC)
- Input capture register D (ICRD)
- Output compare register AR (OCRAR)
- Output compare register AF (OCRAF)
- Output compare register DM (OCRDM)
- Timer interrupt enable register (TIER)
- Timer control/status register (TCSR)
- Timer control register (TCR)
- Timer output compare control register (TOCR)

Note: OCRA and OCRB share the same address. Register selection is controlled by the OCRS bit in TOCR. ICRA, ICRB, and ICRC share the same addresses with OCRAR, OCRAF, and OCRDM. Register selection is controlled by the ICRS bit in TOCR.

11.3.1 Free-Running Counter (FRC)

FRC is a 16-bit readable/writable up-counter. The clock source is selected by bits CKS1 and CKS0 in TCR. FRC can be cleared by compare-match A. When FRC overflows from H'FFFF to H'0000, the overflow flag bit (OVF) in TCSR is set to 1. FRC should always be accessed in 16-bit units; cannot be accessed in 8-bit units. FRC is initialized to H'0000.

11.3.2 Output Compare Registers A and B (OCRA and OCRB)

The FRT has two output compare registers, OCRA and OCRB, each of which is a 16-bit readable/writable register whose contents are continually compared with the value in FRC. When a match is detected (compare-match), the corresponding output compare flag (OCFA or OCFB) is set to 1 in TCSR. If the OEA or OEB bit in TOCR is set to 1, when the OCR and FRC values match, the output level selected by the OLVLA or OLVLB bit in TOCR is output at the output compare output pin (FTOA or FTOB). Following a reset, the FTOA and FTOB output levels are 0 until the first compare-match. OCR should always be accessed in 16-bit units; cannot be accessed in 8-bit units. OCR is initialized to H'FFFF.

11.3.3 Input Capture Registers A to D (ICRA to ICRD)

The FRT has four input capture registers, ICRA to ICRD, each of which is a 16-bit read-only register. When the rising or falling edge of the signal at an input capture input pin (FTIA to FTID) is detected, the current FRC value is transferred to the corresponding input capture register (ICRA to ICRD). At the same time, the corresponding input capture flag (ICFA to ICFD) in TCSR is set to 1. The FRC contents are transferred to ICR regardless of the value of ICF. The input capture edge is selected by the input edge select bits (IEDGA to IEDGD) in TCR.

ICRC and ICRD can be used as ICRA and ICRB buffer registers, respectively, by means of buffer enable bits A and B (BUFEA and BUFEB) in TCR. For example, if an input capture occurs when ICRC is specified as the ICRA buffer register, the FRC contents are transferred to ICRA, and then transferred to the buffer register ICRC. When IEDGA and IEDGC bits in TCR are set to different values, both rising and falling edges can be specified as the change of the external input signal.

To ensure input capture, the input capture pulse width should be at least 1.5 system clocks (ϕ) for a single edge. When triggering is enabled on both edges, the input capture pulse width should be at least 2.5 system clocks (ϕ).

ICRA to ICRD should always be accessed in 16-bit units; cannot be accessed in 8-bit units. ICR is initialized to H'0000.

11.3.4 Output Compare Registers AR and AF (OCRAR and OCRAF)

OCRAR and OCRAF are 16-bit readable/writable registers. When the OCRAMS bit in TOCR is set to 1, the operation of OCRA is changed to include the use of OCRAR and OCRAF. The contents of OCRAR and OCRAF are automatically added alternately to OCRA, and the result is written to OCRA. The write operation is performed on the occurrence of compare-match A. In the 1st compare-match A after setting the OCRAMS bit to 1, OCRAF is added. The operation due to compare-match A varies according to whether the compare-match follows addition of OCRAR or OCRAF. The value of the OLVLA bit in TOCR is ignored, and 1 is output on a compare-match A following addition of OCRAF, while 0 is output on a compare-match A following addition of OCRAR.

When using the OCRA automatic addition function, do not select internal clock $\phi/2$ as the FRC input clock together with a set value of H'0001 or less for OCRAR (or OCRAF).

OCRAR and OCRAF should always be accessed in 16-bit units; cannot be accessed in 8-bit units. OCRAR and OCRAF are initialized to H'FFFF.

11.3.5 Output Compare Register DM (OCRDM)

OCRDM is a 16-bit readable/writable register in which the upper eight bits are fixed at H'00. When the ICRDMS bit in TOCR is set to 1 and the contents of OCRDM are other than H'0000, the operation of ICRD is changed to include the use of OCRDM. The point at which input capture D occurs is taken as the start of a mask interval. Next, twice the contents of OCRDM is added to the contents of ICRD, and the result is compared with the FRC value. The point at which the values match is taken as the end of the mask interval. New input capture D events are disabled during the mask interval. A mask interval is not generated when the contents of OCRDM are H'0000 while the ICRDMS bit is set to 1.

OCRDM should always be accessed in 16-bit units; cannot be accessed in 8-bit units. OCRDM is initialized to H'0000.

11.3.6 Timer Interrupt Enable Register (TIER)

TIER enables and disables interrupt requests.

Bit	Bit Name	Initial Value	R/W	Description
7	ICIAE	0	R/W	<p>Input Capture Interrupt A Enable</p> <p>Selects whether to enable input capture interrupt A request (ICIA) when input capture flag A (ICFA) in TCSR is set to 1.</p> <p>0: ICIA requested by ICFA is disabled 1: ICIA requested by ICFA is enabled</p>
6	ICIBE	0	R/W	<p>Input Capture Interrupt B Enable</p> <p>Selects whether to enable input capture interrupt B request (ICIB) when input capture flag B (ICFB) in TCSR is set to 1.</p> <p>0: ICIB requested by ICFB is disabled 1: ICIB requested by ICFB is enabled</p>
5	ICICE	0	R/W	<p>Input Capture Interrupt C Enable</p> <p>Selects whether to enable input capture interrupt C request (ICIC) when input capture flag C (ICFC) in TCSR is set to 1.</p> <p>0: ICIC requested by ICFC is disabled 1: ICIC requested by ICFC is enabled</p>
4	ICIDE	0	R/W	<p>Input Capture Interrupt D Enable</p> <p>Selects whether to enable input capture interrupt D request (ICID) when input capture flag D (ICFD) in TCSR is set to 1.</p> <p>0: ICID requested by ICFD is disabled 1: ICID requested by ICFD is enabled</p>
3	OCIAE	0	R/W	<p>Output Compare Interrupt A Enable</p> <p>Selects whether to enable output compare interrupt A request (OCIA) when output compare flag A (OCFA) in TCSR is set to 1.</p> <p>0: OCIA requested by OCFA is disabled 1: OCIA requested by OCFA is enabled</p>

Bit	Bit Name	Initial Value	R/W	Description
2	OCIBE	0	R/W	<p>Output Compare Interrupt B Enable</p> <p>Selects whether to enable output compare interrupt B request (OCIB) when output compare flag B (OCFB) in TCSR is set to 1.</p> <p>0: OCIB requested by OCFB is disabled 1: OCIB requested by OCFB is enabled</p>
1	OVIE	0	R/W	<p>Timer Overflow Interrupt Enable</p> <p>Selects whether to enable a free-running timer overflow request interrupt (FOVI) when the timer overflow flag (OVF) in TCSR is set to 1.</p> <p>0: FOVI requested by OVF is disabled 1: FOVI requested by OVF is enabled</p>
0	—	0	R	<p>Reserved</p> <p>This bit is always read as 1 and cannot be modified.</p>

11.3.7 Timer Control/Status Register (TCSR)

TCSR is used for counter clear selection and control of interrupt request signals.

Bit	Bit Name	Initial Value	R/W	Description
7	ICFA	0	R/(W)*	<p>Input Capture Flag A</p> <p>This status flag indicates that the FRC value has been transferred to ICRA by means of an input capture signal. When BUFEA = 1, ICFA indicates that the old ICRA value has been moved into ICRC and the new FRC value has been transferred to ICRA.</p> <p>[Setting condition]</p> <p>When an input capture signal causes the FRC value to be transferred to ICRA</p> <p>[Clearing condition]</p> <p>Read ICFA when ICFA = 1, then write 0 to ICFA</p>

Bit	Bit Name	Initial Value	R/W	Description
6	ICFB	0	R/(W)*	<p>Input Capture Flag B</p> <p>This status flag indicates that the FRC value has been transferred to ICRB by means of an input capture signal. When BUFEB = 1, ICFB indicates that the old ICRB value has been moved into ICRD and the new FRC value has been transferred to ICRB.</p> <p>[Setting condition]</p> <p>When an input capture signal causes the FRC value to be transferred to ICRB</p> <p>[Clearing condition]</p> <p>Read ICFB when ICFB = 1, then write 0 to ICFB</p>
5	ICFC	0	R/(W)*	<p>Input Capture Flag C</p> <p>This status flag indicates that the FRC value has been transferred to ICRC by means of an input capture signal. When BUFEA = 1, on occurrence of an input capture signal specified by the IEDGC bit at the FTIC input pin, ICFC is set but data is not transferred to ICRC. In buffer operation, ICFC can be used as an external interrupt signal by setting the ICICE bit to 1.</p> <p>[Setting condition]</p> <p>When an input capture signal is received</p> <p>[Clearing condition]</p> <p>Read ICFC when ICFC = 1, then write 0 to ICFC</p>
4	ICFD	0	R/(W)*	<p>Input Capture Flag D</p> <p>This status flag indicates that the FRC value has been transferred to ICRD by means of an input capture signal. When BUFEB = 1, on occurrence of an input capture signal specified by the IEDGD bit at the FTID input pin, ICFD is set but data is not transferred to ICRD. In buffer operation, ICFD can be used as an external interrupt signal by setting the ICIDE bit to 1.</p> <p>[Setting condition]</p> <p>When an input capture signal is received</p> <p>[Clearing condition]</p> <p>Read ICFD when ICFD = 1, then write 0 to ICFD</p>

Bit	Bit Name	Initial Value	R/W	Description
3	OCFA	0	R/(W)*	<p>Output Compare Flag A</p> <p>This status flag indicates that the FRC value matches the OCRA value.</p> <p>[Setting condition] When FRC = OCRA</p> <p>[Clearing condition] Read OCFA when OCFA = 1, then write 0 to OCFA</p>
2	OCFB	0	R/(W)*	<p>Output Compare Flag B</p> <p>This status flag indicates that the FRC value matches the OCRB value.</p> <p>[Setting condition] When FRC = OCRB</p> <p>[Clearing condition] Read OCFB when OCFB = 1, then write 0 to OCFB</p>
1	OVF	0	R/(W)*	<p>Overflow Flag</p> <p>This status flag indicates that the FRC has overflowed.</p> <p>[Setting condition] When FRC overflows (changes from H'FFFF to H'0000)</p> <p>[Clearing condition] Read OVF when OVF = 1, then write 0 to OVF</p>
0	CCLRA	0	R/W	<p>Counter Clear A</p> <p>This bit selects whether the FRC is to be cleared at compare-match A (when the FRC and OCRA values match).</p> <p>0: FRC clearing is disabled 1: FRC is cleared at compare-match A</p>

Note: * Only 0 can be written to clear the flag.

11.3.8 Timer Control Register (TCR)

TCR selects the rising or falling edge of the input capture signals, enables the input capture buffer mode, and selects the FRC clock source.

Bit	Bit Name	Initial Value	R/W	Description
7	IEDGA	0	R/W	Input Edge Select A Selects the rising or falling edge of the input capture A signal (FTIA). 0: Capture on the falling edge of FTIA 1: Capture on the rising edge of FTIA
6	IEDGB	0	R/W	Input Edge Select B Selects the rising or falling edge of the input capture B signal (FTIB). 0: Capture on the falling edge of FTIB 1: Capture on the rising edge of FTIB
5	IEDGC	0	R/W	Input Edge Select C Selects the rising or falling edge of the input capture C signal (FTIC). 0: Capture on the falling edge of FTIC 1: Capture on the rising edge of FTIC
4	IEDGD	0	R/W	Input Edge Select D Selects the rising or falling edge of the input capture D signal (FTID). 0: Capture on the falling edge of FTID 1: Capture on the rising edge of FTID
3	BUFEA	0	R/W	Buffer Enable A Selects whether ICRC is to be used as a buffer register for ICRA. 0: ICRC is not used as a buffer register for ICRA 1: ICRC is used as a buffer register for ICRA
2	BUFEB	0	R/W	Buffer Enable B Selects whether ICRD is to be used as a buffer register for ICRB. 0: ICRD is not used as a buffer register for ICRB 1: ICRD is used as a buffer register for ICRB

Bit	Bit Name	Initial Value	R/W	Description
1	CKS1	0	R/W	Clock Select 1 and 0
0	CKS0	0	R/W	Select clock source for FRC. 00: $\phi/2$ internal clock source 01: $\phi/8$ internal clock source 10: $\phi/32$ internal clock source 11: External clock source (counting at FTCl rising edge)

11.3.9 Timer Output Compare Control Register (TOCR)

TOCR enables output from the output compare pins, selects the output levels, switches access between output compare registers A and B, controls the ICRD and OCRA operating modes, and switches access to input capture registers A, B, and C.

Bit	Bit Name	Initial Value	R/W	Description
7	ICRDMS	0	R/W	Input Capture D Mode Select Specifies whether ICRD is used in the normal operating mode or in the operating mode using OCRDM. 0: The normal operating mode is specified for ICRD 1: The operating mode using OCRDM is specified for ICRD
6	OCRAMS	0	R/W	Output Compare A Mode Select Specifies whether OCRA is used in the normal operating mode or in the operating mode using OCRAR and OCRAF. 0: The normal operating mode is specified for OCRA 1: The operating mode using OCRAR and OCRAF is specified for OCRA
5	ICRS	0	R/W	Input Capture Register Select The same addresses are shared by ICRA and OCRAR, by ICRB and OCRAF, and by ICRC and OCRDM. The ICRS bit determines which registers are selected when the shared addresses are read from or written to. The operation of ICRA, ICRB, and ICRC is not affected. 0: ICRA, ICRB, and ICRC are selected 1: OCRAR, OCRAF, and OCRDM are selected

Bit	Bit Name	Initial Value	R/W	Description
4	OCRS	0	R/W	<p>Output Compare Register Select</p> <p>OCRA and OCRB share the same address. When this address is accessed, the OCRS bit selects which register is accessed. The operation of OCRA or OCRB is not affected.</p> <p>0: OCRA is selected</p> <p>1: OCRB is selected</p>
3	OEA	0	R/W	<p>Output Enable A</p> <p>Enables or disables output of the output compare A output pin (FTOA).</p> <p>0: Output compare A output is disabled</p> <p>1: Output compare A output is enabled</p>
2	OEB	0	R/W	<p>Output Enable B</p> <p>Enables or disables output of the output compare B output pin (FTOB).</p> <p>0: Output compare B output is disabled</p> <p>1: Output compare B output is enabled</p>
1	OLVLA	0	R/W	<p>Output Level A</p> <p>Selects the level to be output at the output compare A output pin (FTOA) in response to compare-match A (signal indicating a match between the FRC and OCRA values). When the OCRAMS bit is 1, this bit is ignored.</p> <p>0: 0 is output at compare-match A</p> <p>1: 1 is output at compare-match A</p>
0	OLVLB	0	R/W	<p>Output Level B</p> <p>Selects the level to be output at the output compare B output pin (FTOB) in response to compare-match B (signal indicating a match between the FRC and OCRB values).</p> <p>0: 0 is output at compare-match B</p> <p>1: 1 is output at compare-match B</p>

11.4 Operation

11.4.1 Pulse Output

Figure 11.2 shows an example of 50%-duty pulses output with an arbitrary phase difference. When a compare match occurs while the CCLRA bit in TCSR is set to 1, the OLVLA and OLVLB bits are inverted by software.

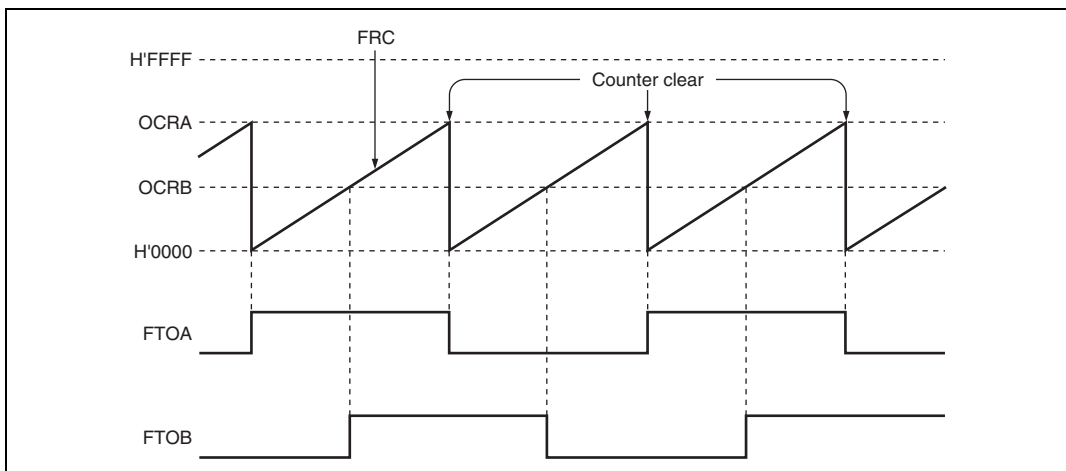

Figure 11.2 Example of Pulse Output

11.5 Operation Timing

11.5.1 FRC Increment Timing

Figure 11.3 shows the FRC increment timing with an internal clock source. Figure 11.4 shows the increment timing with an external clock source. The pulse width of the external clock signal must be at least 1.5 system clocks (ϕ). The counter will not increment correctly if the pulse width is shorter than 1.5 system clocks (ϕ).

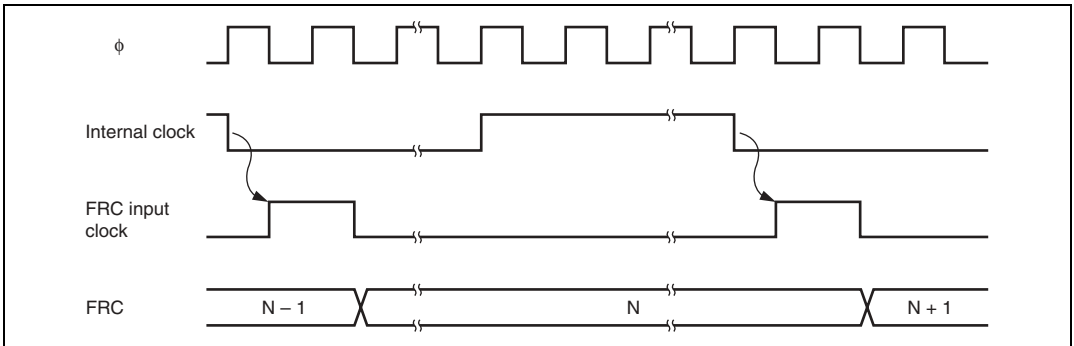

Figure 11.3 Increment Timing with Internal Clock Source

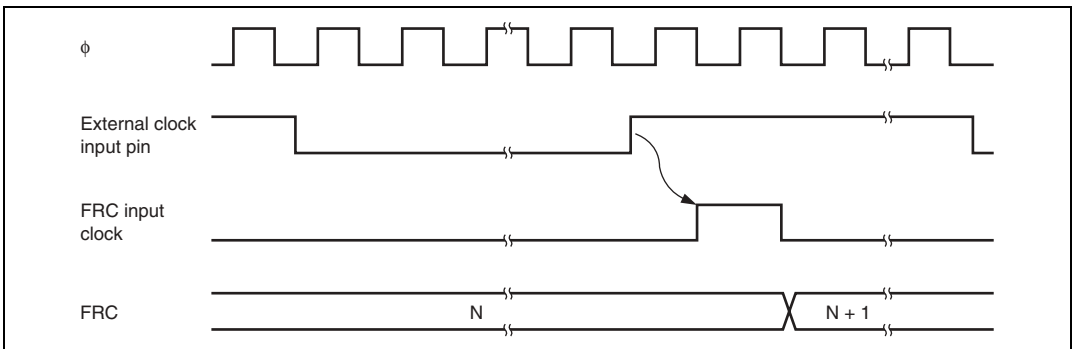

Figure 11.4 Increment Timing with External Clock Source

11.5.2 Output Compare Output Timing

A compare-match signal occurs at the last state when the FRC and OCR values match (at the timing when the FRC updates the counter value). When a compare-match signal occurs, the level selected by the OLVL bit in TOCR is output at the output compare pin (FTOA or FTOB). Figure 11.5 shows the timing of this operation for compare-match A.

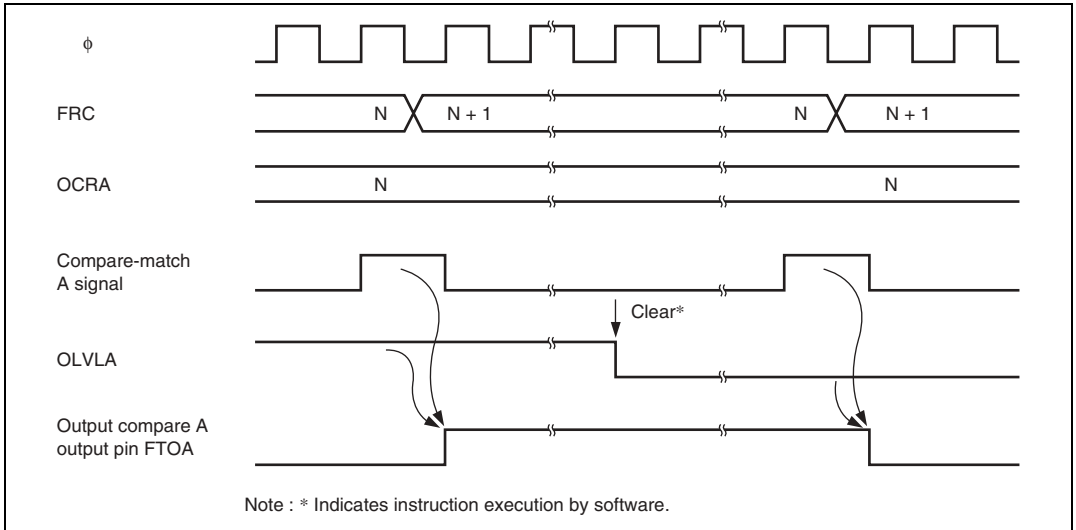

Figure 11.5 Timing of Output Compare A Output

11.5.3 FRC Clear Timing

FRC can be cleared when compare-match A occurs. Figure 11.6 shows the timing of this operation.

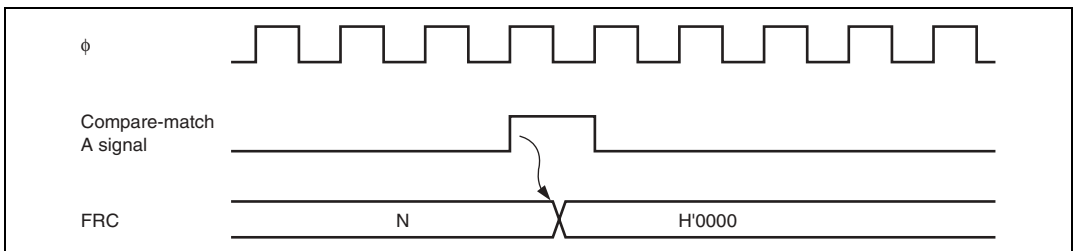

Figure 11.6 Clearing of FRC by Compare-Match A Signal

11.5.4 Input Capture Input Timing

The rising or falling edge can be selected for the input capture input timing by the IEDGA to IEDGD bits in TCR. Figure 11.7 shows the usual input capture timing when the rising edge is selected.

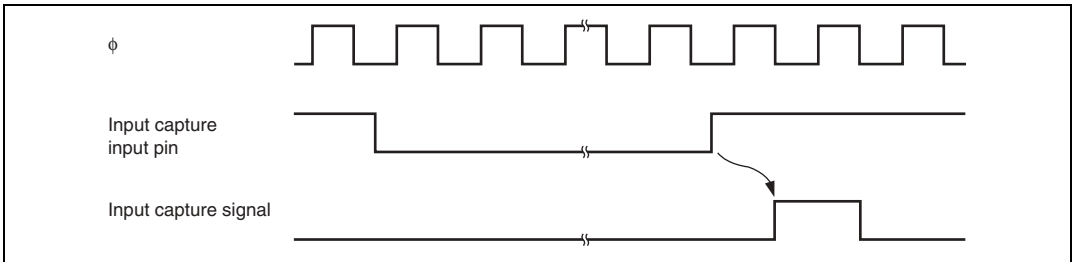

Figure 11.7 Input Capture Input Signal Timing (Usual Case)

If ICRA to ICRD are read when the corresponding input capture signal arrives, the internal input capture signal is delayed by one system clock (ϕ). Figure 11.8 shows the timing for this case.

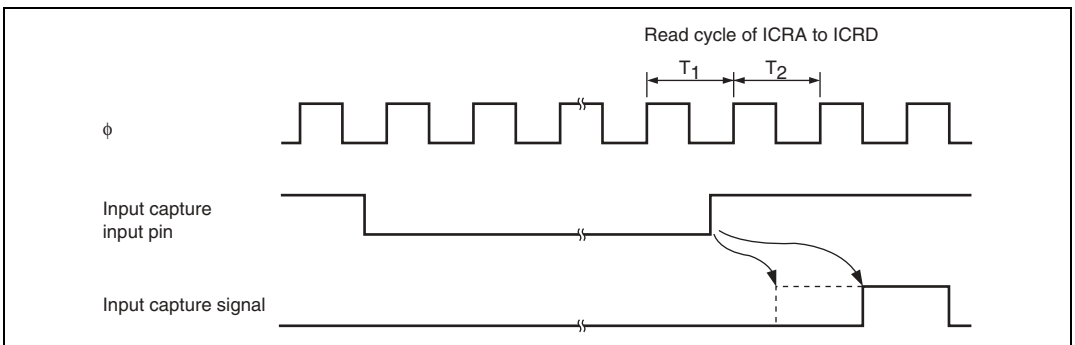

Figure 11.8 Input Capture Input Signal Timing (When ICRA to ICRD is Read)

11.5.5 Buffered Input Capture Input Timing

ICRC and ICRD can operate as buffers for ICRA and ICRB, respectively. Figure 11.9 shows how input capture operates when ICRC is used as ICRA's buffer register (BUFEA = 1) and IEDGA and IEDGC are set to different values (IEDGA = 0 and IEDGC = 1, or IEDGA = 1 and IEDGC = 0), so that input capture is performed on both the rising and falling edges of FTIA.

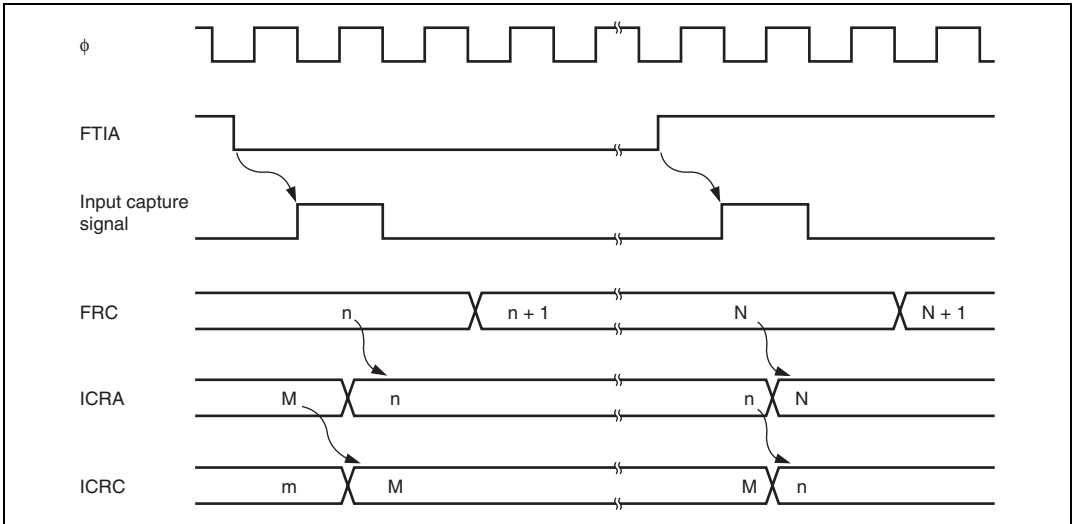

Figure 11.9 Buffered Input Capture Timing

Even when ICRC or ICRD is used as a buffer register, its input capture flag is set by the selected transition of its input capture signal. For example, if ICRC is used to buffer ICRA, when the edge transition selected by the IEDGC bit occurs on the FTIC input capture line, ICFC will be set, and if the ICICE bit is set at this time, an interrupt will be requested. The FRC value will not be transferred to ICRC, however. In buffered input capture, if either set of two registers to which data will be transferred (ICRA and ICRC, or ICRB and ICRD) is being read when the input capture input signal arrives, input capture is delayed by one system clock (ϕ). Figure 11.10 shows the timing when BUFEA = 1.

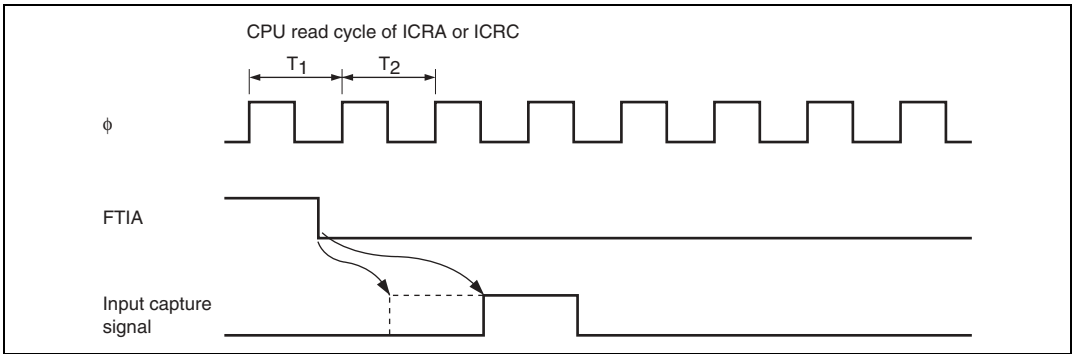

Figure 11.10 Buffered Input Capture Timing (BUFEA = 1)

11.5.6 Timing of Input Capture Flag (ICF) Setting

The input capture flag, ICFA to ICFD, is set to 1 by the input capture signal. The FRC value is simultaneously transferred to the corresponding input capture register (ICRA to ICRD). Figure 11.11 shows the timing of setting the ICFA to ICFD flag.

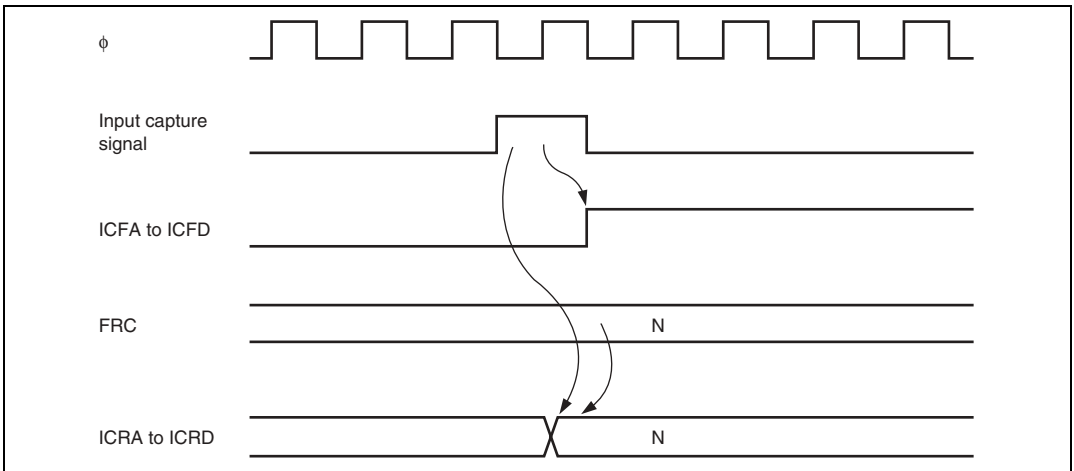

Figure 11.11 Timing of Input Capture Flag (ICFA to ICFD) Setting

11.5.7 Timing of Output Compare Flag (OCF) setting

The output compare flag, OCFA or OCFB, is set to 1 by a compare-match signal generated when the FRC value matches the OCRA or OCRB value. This compare-match signal is generated at the last state in which the two values match, just before FRC increments to a new value. When the FRC and OCRA or OCRB value match, the compare-match signal is not generated until the next cycle of the clock source. Figure 11.12 shows the timing of setting the OCFA or OCFB flag.

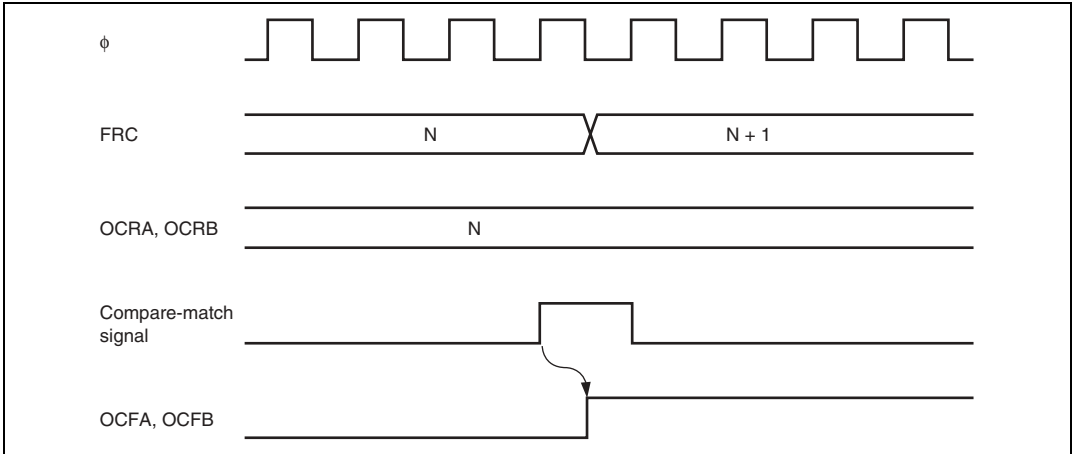

Figure 11.12 Timing of Output Compare Flag (OCFA or OCFB) Setting

11.5.8 Timing of FRC Overflow Flag (OVF) Setting

The FRC overflow flag (OVF) is set to 1 when FRC overflows (changes from H'FFFF to H'0000). Figure 11.13 shows the timing of setting the OVF flag.

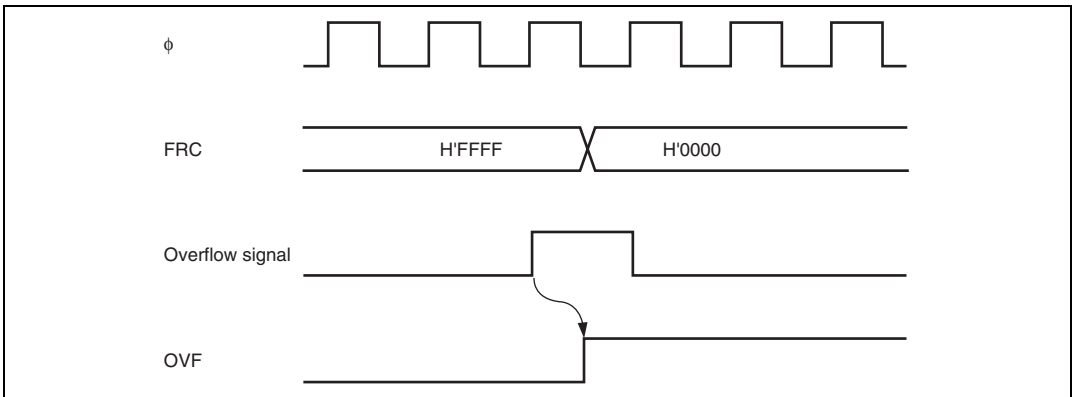

Figure 11.13 Timing of Overflow Flag (OVF) Setting

11.5.9 Automatic Addition Timing

When the OCRAMS bit in TOCR is set to 1, the contents of OCRAR and OCRAF are automatically added to OCRA alternately, and when an OCRA compare-match occurs a write to OCRA is performed. Figure 11.14 shows the OCRA write timing.

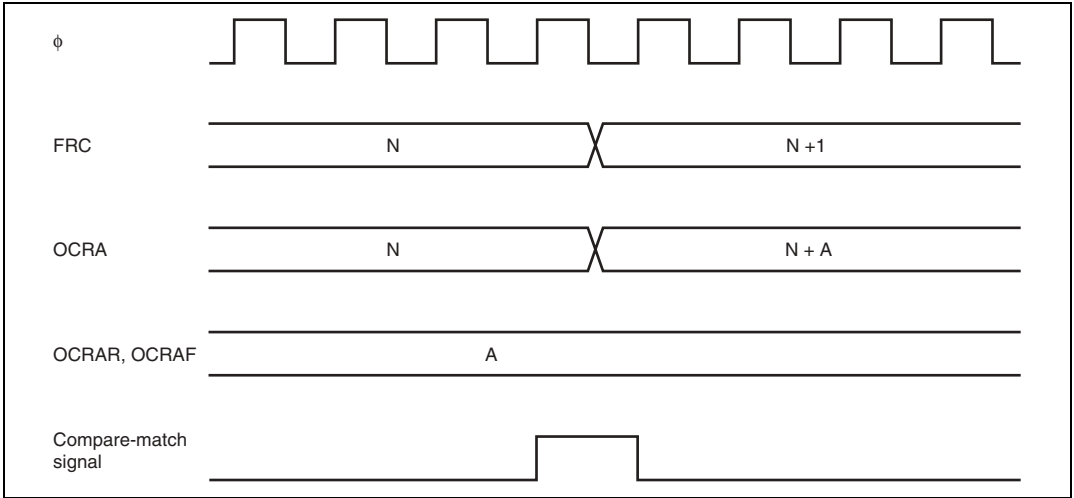

Figure 11.14 OCRA Automatic Addition Timing

11.5.10 Mask Signal Generation Timing

When the ICRDMS bit in TOCR is set to 1 and the contents of OCRDM are other than H'0000, a signal that masks the ICRD input capture signal is generated. The mask signal is set by the input capture signal. The mask signal is cleared by the sum of the ICRD contents and twice the OCRDM contents, and an FRC compare-match. Figure 11.15 shows the timing of setting the mask signal. Figure 11.16 shows the timing of clearing the mask signal.

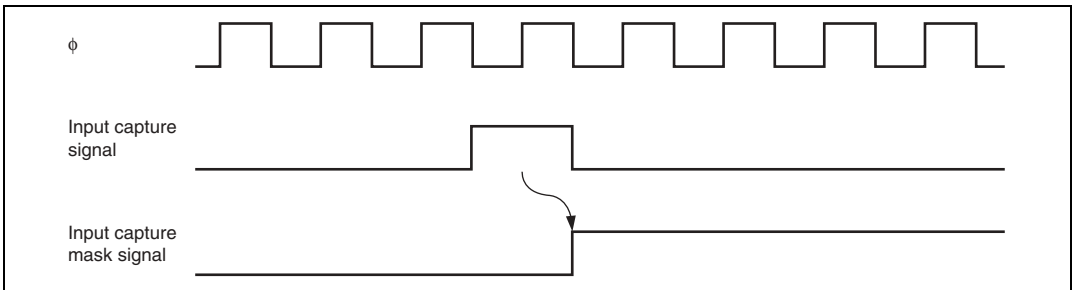

Figure 11.15 Timing of Input Capture Mask Signal Setting

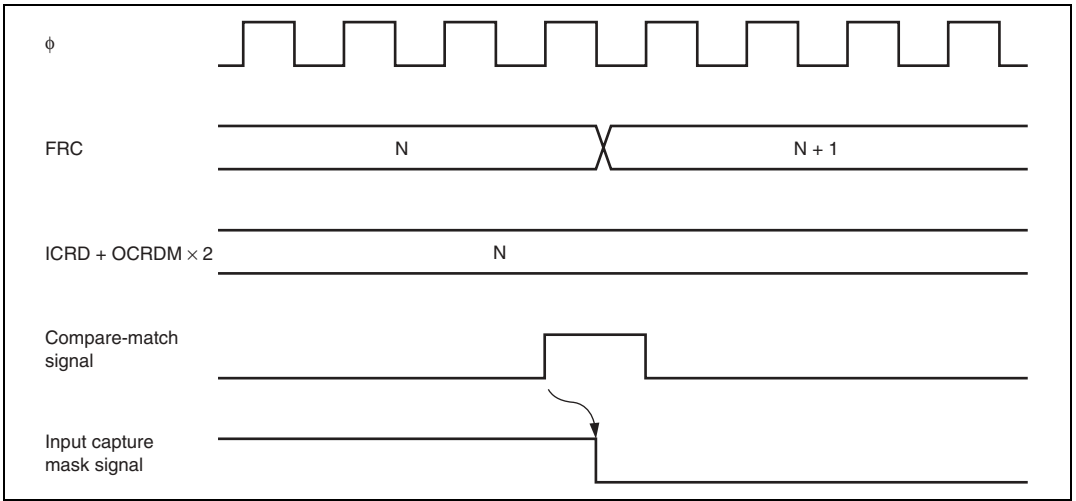



Figure 11.16 Timing of Input Capture Mask Signal Clearing

11.6 Interrupt Sources

The free-running timer can request seven interrupts: ICIA to ICID, OCIA, OCIB, and FOVI. Each interrupt can be enabled or disabled by an enable bit in TIER. Independent signals are sent to the interrupt controller for each interrupt. Table 11.2 lists the sources and priorities of these interrupts.

The ICIA, ICIB, OCIA, and OCIB interrupts can be used as the on-chip DTC activation sources.

Table 11.2 FRT Interrupt Sources

Interrupt	Interrupt Source	Interrupt Flag	DTC Activation	Priority
ICIA	Input capture of ICRA	ICFA	Possible	High
ICIB	Input capture of ICRB	ICFB	Possible	
ICIC	Input capture of ICRC	ICFC	Not possible	
ICID	Input capture of ICRD	ICFD	Not possible	
OCIA	Compare match of OCRA	OCFA	Possible	
OCIB	Compare match of OCRB	OCFB	Possible	
FOVI	Overflow of FRC	OVF	Not possible	

11.7 Usage Notes

11.7.1 Conflict between FRC Write and Clear

If an internal counter clear signal is generated during the state after an FRC write cycle, the clear signal takes priority and the write is not performed. Figure 11.17 shows the timing for this type of conflict.

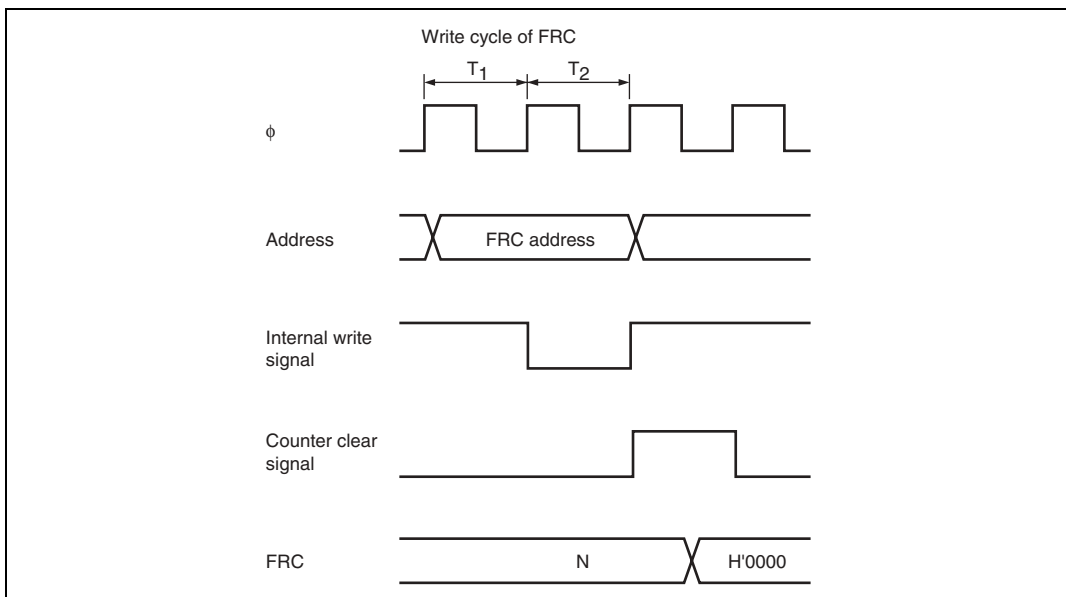

Figure 11.17 Conflict between FRC Write and Clear

11.7.2 Conflict between FRC Write and Increment

If an FRC increment pulse is generated during the state after an FRC write cycle, the write takes priority and FRC is not incremented. Figure 11.18 shows the timing for this type of conflict.

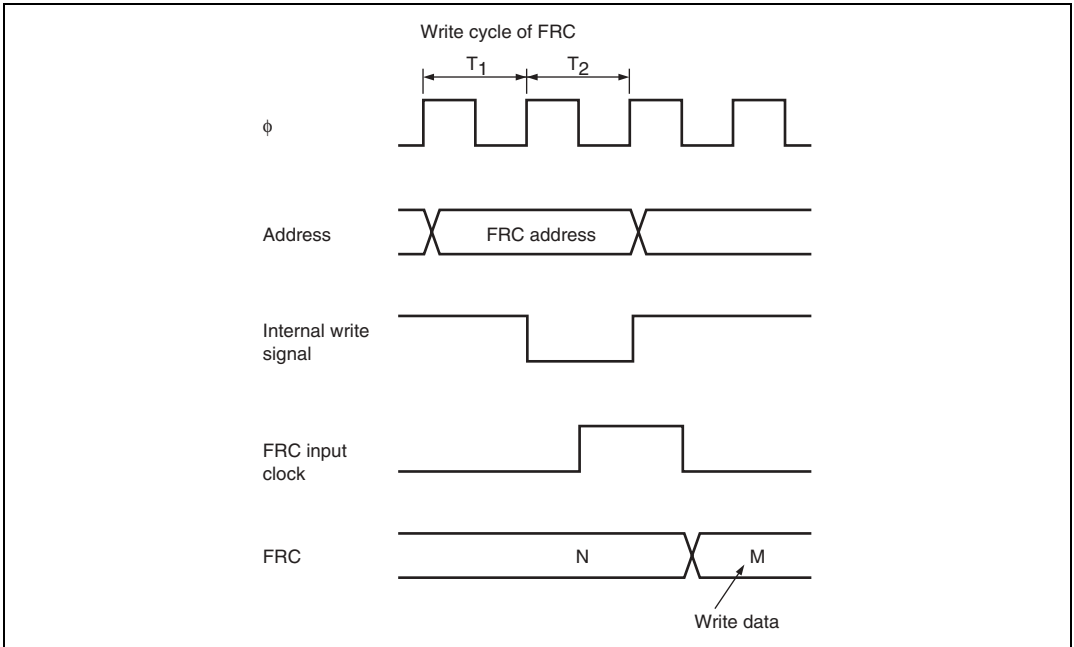
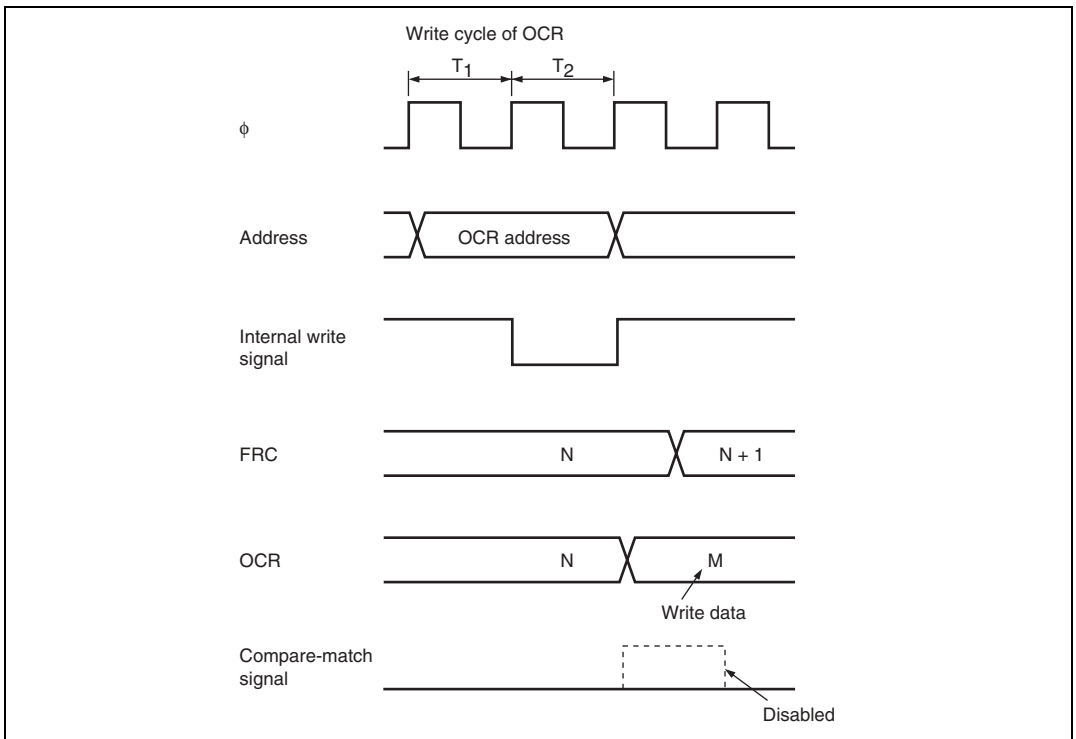

Figure 11.18 Conflict between FRC Write and Increment

11.7.3 Conflict between OCR Write and Compare-Match

If a compare-match occurs during the state after an OCRA or OCRB write cycle, the write takes priority and the compare-match signal is disabled. Figure 11.19 shows the timing for this type of conflict.

If automatic addition of OCRAR and OCRAF to OCRA is selected, and a compare-match occurs in the cycle following the OCRA, OCRAR, and OCRAF write cycle, the OCRA, OCRAR and OCRAF write takes priority and the compare-match signal is disabled. Consequently, the result of the automatic addition is not written to OCRA. Figure 11.20 shows the timing for this type of conflict.



**Figure 11.19 Conflict between OCR Write and Compare-Match
(When Automatic Addition Function is Not Used)**

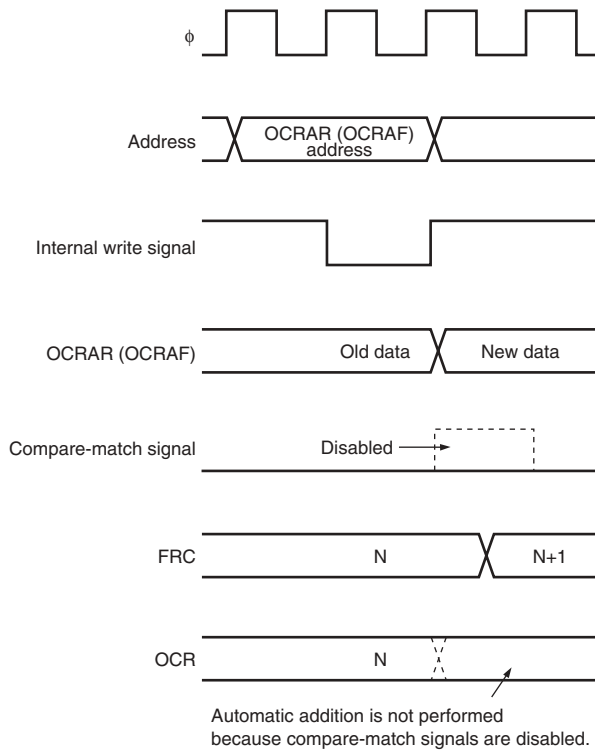

**Figure 11.20 Conflict between OCR Write and Compare-Match
(When Automatic Addition Function is Used)**

11.7.4 Switching of Internal Clock and FRC Operation

When the internal clock is changed, the changeover may source FRC to increment. This depends on the time at which the clock is switched (bits CKS1 and CKS0 are rewritten), as shown in table 11.3.

When an internal clock is used, the FRC clock is generated on detection of the falling edge of the internal clock scaled from the system clock (ϕ). If the clock is changed when the old source is high and the new source is low, as in case no. 3 in table 11.3, the changeover is regarded as a falling edge that triggers the FRC clock, and FRC is incremented. Switching between an internal clock and external clock can also source FRC to increment.

Table 11.3 Switching of Internal Clock and FRC Operation

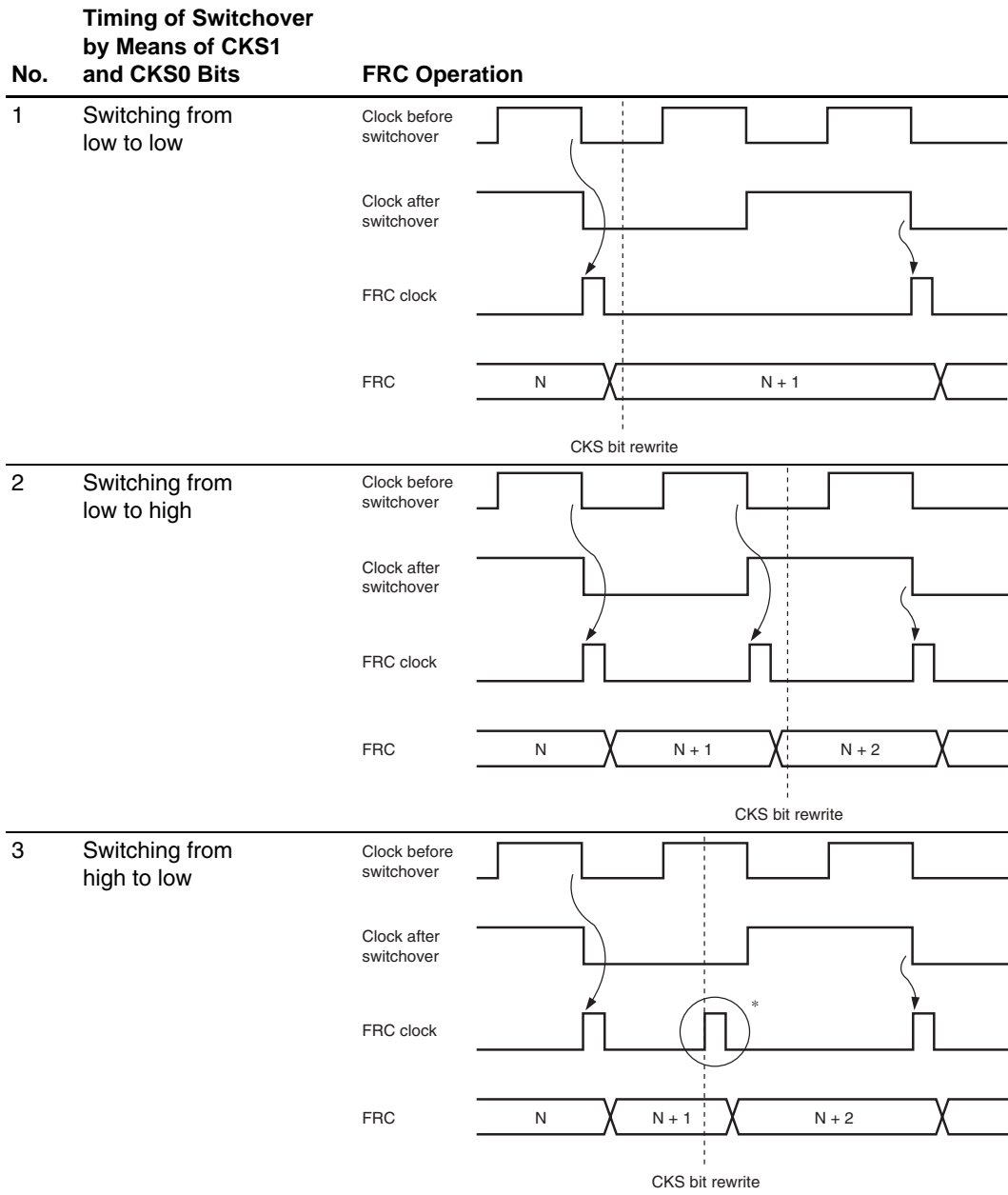
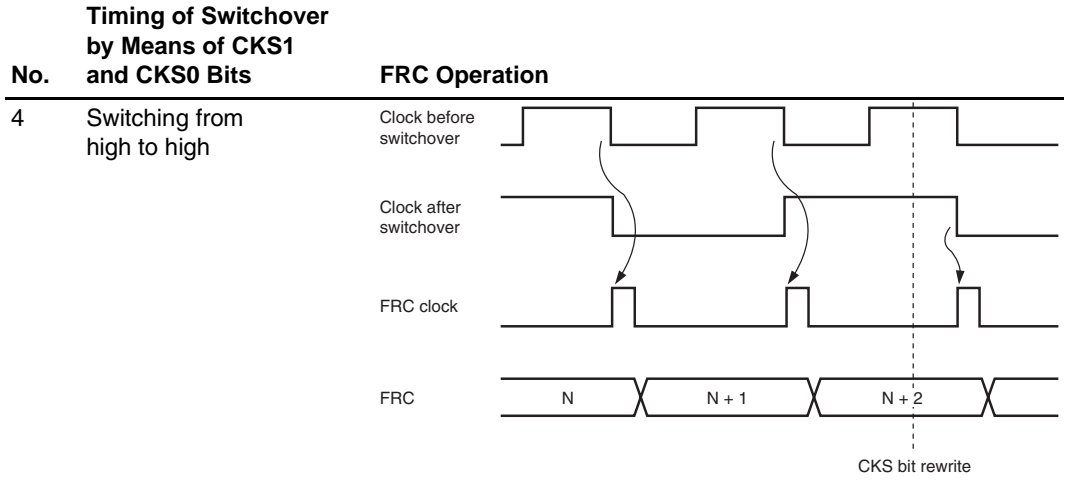

Table 11.3 Switching of Internal Clock and FRC Operation (cont)



Note: * Generated on the assumption that the switchover is a falling edge; FRC is incremented.

Section 12 8-Bit Timer (TMR)

This LSI has an on-chip 8-bit timer module (TMR_0 and TMR_1) with two channels operating on the basis of an 8-bit counter. The 8-bit timer module can be used as a multifunction timer in a variety of applications, such as generation of counter reset, interrupt requests, and pulse output with an arbitrary duty cycle using a compare-match signal with two registers.

This LSI also has a similar on-chip 8-bit timer module (TMR_Y and TMR_X) with two channels.

12.1 Features

- Selection of clock sources
 - TMR_0, TMR_1: The counter input clock can be selected from six internal clocks and an external clock
 - TMR_Y, TMR_X: The counter input clock can be selected from three internal clocks and an external clock
- Selection of three ways to clear the counters
 - The counters can be cleared on compare-match A, compare-match B, or by an external reset signal.
- Timer output controlled by two compare-match signals
 - The timer output signal in each channel is controlled by two independent compare-match signals, enabling the timer to be used for various applications, such as the generation of pulse output or PWM output with an arbitrary duty cycle.
- Cascading of TMR_0 and TMR_1
(Cascading of TMR_Y and TMR_X is not allowed)
 - Operation as a 16-bit timer can be performed using TMR_0 as the upper half and TMR_1 as the lower half (16-bit count mode). TMR_1 can be used to count TMR_0 compare match occurrences (compare-match count mode).
- Multiple interrupt sources for each channel
 - TMR_0, TMR_1,
and TMR_Y: Three types of interrupts: Compare-match A, compare-match B, and overflow
 - TMR_X: Four types of interrupts: Compare-match A, compare-match B, overflow, and input capture

Figures 12.1 and 12.2 show block diagrams of 8-bit timers.

An input capture function is added to TMR_X.

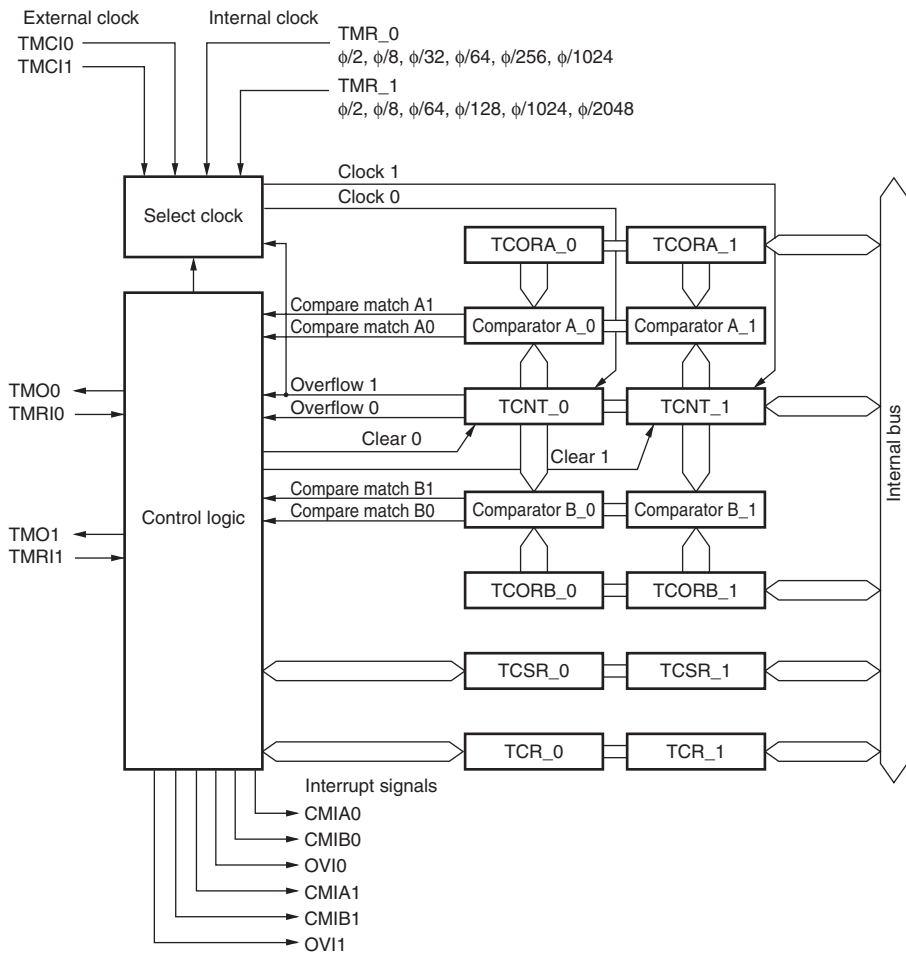

[Legend]

TCORA_0: Time constant register A_0

TCORB_0: Time constant register B_0

TCNT_0: Timer counter_0

TCSR_0: Timer control/status register_0

TCR_0: Timer control register_0

TCORA_1: Time constant register A_1

TCORB_1: Time constant register B_1

TCNT_1: Timer counter_1

TCSR_1: Timer control/status register_1

TCR_1: Timer control register_1

Figure 12.1 Block Diagram of 8-Bit Timer (TMR_0 and TMR_1)

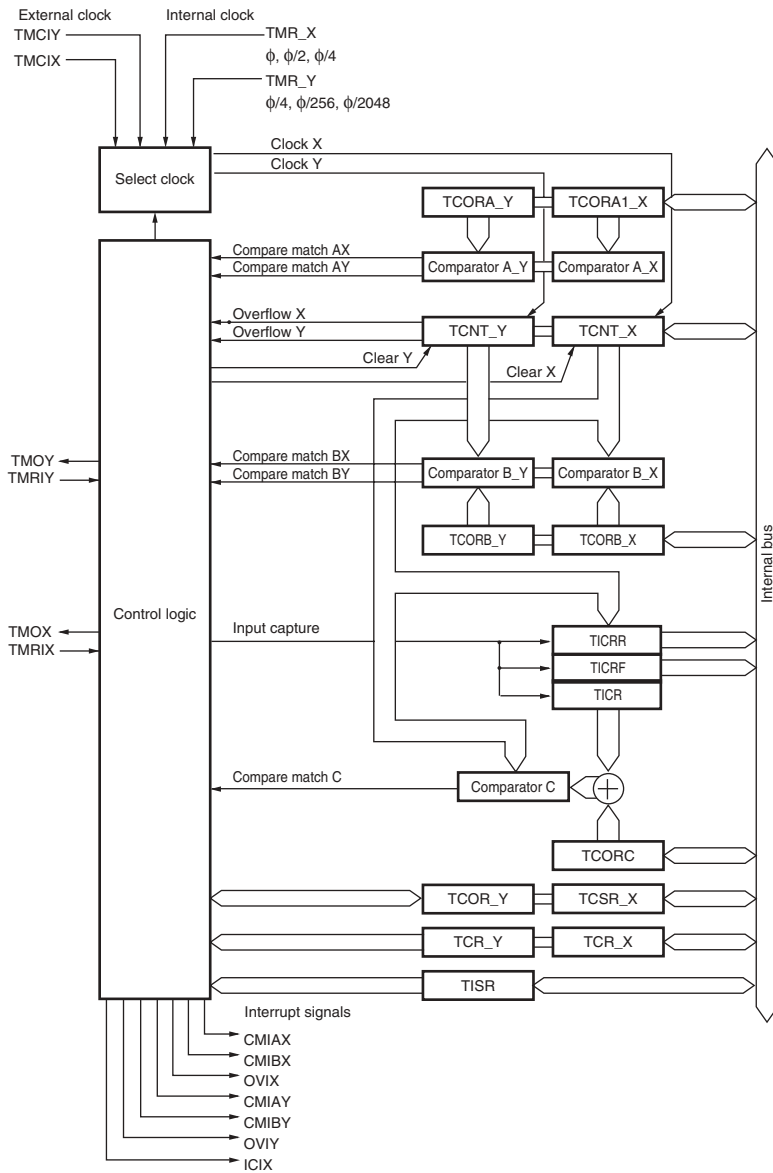

[Legend]

TCORA_Y: Time constant register A_Y
 TCORB_Y: Time constant register B_Y
 TCNT_Y: Timer counter_Y
 TCSR_Y: Timer control / status register_Y
 TCR_Y: Timer control register_Y
 TISR: Timer input select register

TCORA_X: Time constant register A_X
 TCORB_X: Time constant register B_X
 TCNT_X: Timer counter_X
 TCSR_X: Timer control / status register_X
 TCR_X: Timer control register_X
 TICR: Input capture register
 TCORC: Time constant register C
 TICRR: Input capture register R
 TICRF: Input capture register F

Figure 12.2 Block Diagram of 8-Bit Timer (TMR_Y and TMR_X)

12.2 Input/Output Pins

Table 12.1 summarizes the input and output pins of the TMR.

Table 12.1 Pin Configuration

Channel	Name	Symbol	I/O	Function
TMR_0	Timer output	TMO0	Output	Output controlled by compare-match
	Timer clock/reset input	TMIO/ExTMIO	Input	External clock input (TMCI0)/external reset input (TMRI0) for the counter
TMR_1	Timer output	TMO1	Output	Output controlled by compare-match
	Timer clock/reset input	TMI1/ExTMI1	Input	External clock input (TMCI1)/external reset input (TMRI1) for the counter
TMR_Y	Timer output	TMOY	Output	Output controlled by compare-match
	Timer clock/reset input	TMIY/ExTMIY	Input	External clock input (TMCIY)/external reset input (TMRIY) for the counter
TMR_X	Timer output	TMOX	Output	Output controlled by compare-match
	Timer clock/reset input	TMIX/ExTMIX	Input	External clock input (TMCIX)/external reset input (TMRIX) for the counter

12.3 Register Descriptions

The TMR has the following registers for each channel. For details on the serial timer control register, see section 3.2.3, Serial Timer Control Register (STCR).

- Timer counter (TCNT)
- Time constant register A (TCORA)
- Time constant register B (TCORB)
- Timer control register (TCR)
- Timer control/status register (TCSR)
- Input capture register (TICR)*¹
- Time constant register C (TCORC)*¹
- Input capture register R (TICRR)*¹
- Input capture register F (TICRF)*¹
- Timer input select register (TISR)*²
- Timer connection register I (TCONRI)*¹
- Timer connection register S (TCONRS)*¹

Notes: Some of the registers of TMR_X and TMR_Y use the same address. The registers can be switched by the TMRX/Y bit in TCONRS.

1. Only for the TMR_X
2. Only for the TMR_Y

12.3.1 Timer Counter (TCNT)

Each TCNT is an 8-bit readable/writable up-counter. TCNT_0 and TCNT_1 comprise a single 16-bit register, so they can be accessed together by word access. The clock source is selected by the CKS2 to CKS0 bits in TCR. TCNT can be cleared by an external reset input signal, compare-match A signal or compare-match B signal. The method of clearing can be selected by the CCLR1 and CCLR0 bits in TCR. When TCNT overflows (changes from H'FF to H'00), the OVF bit in TCSR is set to 1. TCNT is initialized to H'00.

TCNT_Y can be accessed when the KINWUE bit in SYSCR is 0 and the TMRX/Y bit in TCONRS is 1. TCNT_X can be accessed when the KINWUE bit in SYSCR is 0 and the TMRX/Y bit in TCONRS is 0. See section 3.2.2, System Control Register (SYSCR), and section 12.3.11, Timer Connection Register S (TCONRS).

12.3.2 Time Constant Register A (TCORA)

TCORA is an 8-bit readable/writable register. TCORA_0 and TCORA_1 comprise a single 16-bit register, so they can be accessed together by word access. TCORA is continually compared with the value in TCNT. When a match is detected, the corresponding compare-match flag A (CMFA) in TCSR is set to 1. Note however that comparison is disabled during the T2 state of a TCORA write cycle. The timer output from the TMO pin can be freely controlled by these compare-match A signals and the settings of output select bits OS1 and OS0 in TCSR. TCORA is initialized to H'FF.

TCORA_Y can be accessed when the KINWUE bit in SYSCR is 0 and the TMRX/Y bit in TCONRS is 1. TCORA_X can be accessed when the KINWUE bit in SYSCR is 0 and the TMRX/Y bit in TCONRS is 0. See section 3.2.2, System Control Register (SYSCR), and section 12.3.11, Timer Connection Register S (TCONRS).

12.3.3 Time Constant Register B (TCORB)

TCORB is an 8-bit readable/writable register. TCORB_0 and TCORB_1 comprise a single 16-bit register, so they can be accessed together by word access. TCORB is continually compared with the value in TCNT. When a match is detected, the corresponding compare-match flag B (CMFB) in TCSR is set to 1. Note however that comparison is disabled during the T2 state of a TCORB write cycle. The timer output from the TMO pin can be freely controlled by these compare-match B signals and the settings of output select bits OS3 and OS2 in TCSR. TCORB is initialized to H'FF.

TCORB_Y can be accessed when the KINWUE bit in SYSCR is 0 and the TMRX/Y bit in TCONRS is 1. TCORB_X can be accessed when the KINWUE bit in SYSCR is 0 and the TMRX/Y bit in TCONRS is 0. See section 3.2.2, System Control Register (SYSCR), and section 12.3.11, Timer Connection Register S (TCONRS).

12.3.4 Timer Control Register (TCR)

TCR selects the TCNT clock source and the condition by which TCNT is cleared, and enables/disables interrupt requests.

TCR_Y can be accessed when the KINWUE bit in SYSCR is 0 and the TMRX/Y bit in TCONRS is 1. TCR_X can be accessed when the KINWUE bit in SYSCR is 0 and the TMRX/Y bit in TCONRS is 0. See section 3.2.2, System Control Register (SYSCR), and section 12.3.11, Timer Connection Register S (TCONRS).

Bit	Bit Name	Initial Value	R/W	Description
7	CMIEB	0	R/W	Compare-Match Interrupt Enable B Selects whether the CMFB interrupt request (CMIB) is enabled or disabled when the CMFB flag in TCSR is set to 1. 0: CMFB interrupt request (CMIB) is disabled 1: CMFB interrupt request (CMIB) is enabled
6	CMIEA	0	R/W	Compare-Match Interrupt Enable A Selects whether the CMFA interrupt request (CMIA) is enabled or disabled when the CMFA flag in TCSR is set to 1. 0: CMFA interrupt request (CMIA) is disabled 1: CMFA interrupt request (CMIA) is enabled
5	OVIE	0	R/W	Timer Overflow Interrupt Enable Selects whether the OVF interrupt request (OVI) is enabled or disabled when the OVF flag in TCSR is set to 1. 0: OVF interrupt request (OVI) is disabled 1: OVF interrupt request (OVI) is enabled
4	CCLR1	0	R/W	Counter Clear 1 and 0
3	CCLR0	0	R/W	These bits select the method by which the timer counter is cleared. 00: Clearing is disabled 01: Cleared on compare-match A 10: Cleared on compare-match B 11: Cleared on rising edge of external reset input
2 to 0	CKS2 to CKS0	All 0	R/W	Clock Select 2 to 0 These bits select the clock input to TCNT and count condition, together with the ICKS1 and ICKS0 bits in STCR. For details, see table 12.2.

Table 12.2 Clock Input to TCNT and Count Condition

Channel	TCR			STCR		Description
	CKS2	CKS1	CKS0	ICKS1	ICKS0	
TMR_0	0	0	0	—	—	Disables clock input
	0	0	1	—	0	Increments at falling edge of internal clock $\phi/8$
	0	0	1	—	1	Increments at falling edge of internal clock $\phi/2$
	0	1	0	—	0	Increments at falling edge of internal clock $\phi/64$
	0	1	0	—	1	Increments at falling edge of internal clock $\phi/32$
	0	1	1	—	0	Increments at falling edge of internal clock $\phi/1024$
	0	1	1	—	1	Increments at falling edge of internal clock $\phi/256$
	1	0	0	—	—	Increments at overflow signal from TCNT_1*
TMR_1	0	0	0	—	—	Disables clock input
	0	0	1	0	—	Increments at falling edge of internal clock $\phi/8$
	0	0	1	1	—	Increments at falling edge of internal clock $\phi/2$
	0	1	0	0	—	Increments at falling edge of internal clock $\phi/64$
	0	1	0	1	—	Increments at falling edge of internal clock $\phi/128$
	0	1	1	0	—	Increments at falling edge of internal clock $\phi/1024$
	0	1	1	1	—	Increments at falling edge of internal clock $\phi/2048$
	1	0	0	—	—	Increments at compare-match A from TCNT_0*
	TMR_Y	0	0	0	—	—
0		0	1	—	—	Increments at falling edge of internal clock $\phi/4$
0		1	0	—	—	Increments at falling edge of internal clock $\phi/256$

Table 12.2 Clock Input to TCNT and Count Condition (cont)

Channel	TCR			STCR		Description
	CKS2	CKS1	CKS0	ICKS1	ICKS0	
TMR_Y	0	1	1	—	—	Increments at falling edge of internal clock $\phi/2048$
	1	0	0	—	—	Setting prohibited
TMR_X	0	0	0	—	—	Disables clock input
	0	0	1	—	—	Increments at falling edge of internal clock ϕ
	0	1	0	—	—	Increments at falling edge of internal clock $\phi/2$
	0	1	1	—	—	Increments at falling edge of internal clock $\phi/4$
	1	0	0	—	—	Setting prohibited
Common	1	0	1	—	—	Increments at rising edge of external clock
	1	1	0	—	—	Increments at falling edge of external clock
	1	1	1	—	—	Increments at both rising and falling edges of external clock.

Note: * If the TMR_0 clock input is set as the TCNT_1 overflow signal and the TMR_1 clock input is set as the TCNT_0 compare-match signal simultaneously, a count-up clock cannot be generated. Simultaneous setting of these conditions should therefore be avoided.

12.3.5 Timer Control/Status Register (TCSR)

TCSR indicates the status flags and controls compare-match output. About the TCSR_Y and TCSR_X accesses see section 3.2.2, System Control Register (SYSCR).

- TCSR_0

Bit	Bit Name	Initial Value	R/W	Description
7	CMFB	0	R/(W)*	Compare-Match Flag B [Setting condition] When the values of TCNT_0 and TCORB_0 match [Clearing condition] Read CMFB when CMFB = 1, then write 0 in CMFB
6	CMFA	0	R/(W)*	Compare-Match Flag A [Setting condition] When the values of TCNT_0 and TCORA_0 match [Clearing condition] Read CMFA when CMFA = 1, then write 0 in CMFA
5	OVF	0	R/(W)*	Timer Overflow Flag [Setting condition] When TCNT_0 overflows from H'FF to H'00 [Clearing condition] Read OVF when OVF = 1, then write 0 in OVF
4	ADTE	0	R/W	A/D Trigger Enable Enables or disables A/D converter start requests by compare-match A. 0: A/D converter start requests by compare-match A are disabled 1: A/D converter start requests by compare-match A are enabled
3	OS3	0	R/W	Output Select 3 and 2 These bits specify how the TMO0 pin output level is to be changed by compare-match B of TCORB_0 and TCNT_0. 00: No change 01: 0 is output 10: 1 is output 11: Output is inverted (toggle output)
2	OS2	0	R/W	

Bit	Bit Name	Initial Value	R/W	Description
1	OS1	0	R/W	Output Select 1 and 0
0	OS0	0	R/W	These bits specify how the TMO0 pin output level is to be changed by compare-match A of TCORA_0 and TCNT_0. 00: No change 01: 0 is output 10: 1 is output 11: Output is inverted (toggle output)

Note: * Only 0 can be written, for flag clearing.

- TCSR_1

Bit	Bit Name	Initial Value	R/W	Description
7	CMFB	0	R/(W)*	Compare-Match Flag B [Setting condition] When the values of TCNT_1 and TCORB_1 match [Clearing condition] Read CMFB when CMFB = 1, then write 0 in CMFB
6	CMFA	0	R/(W)*	Compare-Match Flag A [Setting condition] When the values of TCNT_1 and TCORA_1 match [Clearing condition] Read CMFA when CMFA = 1, then write 0 in CMFA
5	OVF	0	R/(W)*	Timer Overflow Flag [Setting condition] When TCNT_1 overflows from H'FF to H'00 [Clearing condition] Read OVF when OVF = 1, then write 0 in OVF
4	—	1	R	Reserved This bit is always read as 1 and cannot be modified.

Bit	Bit Name	Initial Value	R/W	Description
3	OS3	0	R/W	Output Select 3 and 2
2	OS2	0	R/W	These bits specify how the TMO1 pin output level is to be changed by compare-match B of TCORB_1 and TCNT_1. 00: No change 01: 0 is output 10: 1 is output 11: Output is inverted (toggle output)
1	OS1	0	R/W	Output Select 1 and 0
0	OS0	0	R/W	These bits specify how the TMO1 pin output level is to be changed by compare-match A of TCORA_1 and TCNT_1. 00: No change 01: 0 is output 10: 1 is output 11: Output is inverted (toggle output)

Note: * Only 0 can be written, for flag clearing.

- TCSR_Y

This register can be accessed when the KINWUE bit in SYSCR is 0 and the TMRX/Y bit in TCONRS is 1.

Bit	Bit Name	Initial Value	R/W	Description
7	CMFB	0	R/(W)*	Compare-Match Flag B [Setting condition] When the values of TCNT_Y and TCORB_Y match [Clearing condition] Read CMFB when CMFB = 1, then write 0 in CMFB
6	CMFA	0	R/(W)*	Compare-Match Flag A [Setting condition] When the values of TCNT_Y and TCORA_Y match [Clearing condition] Read CMFA when CMFA = 1, then write 0 in CMFA

Bit	Bit Name	Initial Value	R/W	Description
5	OVF	0	R/(W)*	Timer Overflow Flag [Setting condition] When TCNT_Y overflows from H'FF to H'00 [Clearing condition] Read OVF when OVF = 1, then write 0 in OVF
4	ICIE	0	R/W	Input Capture Interrupt Enable [Setting condition] Enables or disables the ICF interrupt request (ICIX) when the ICF bit in TCSR_X is set to 1. 0: ICF interrupt request (ICIX) is disabled 1: ICF interrupt request (ICIX) is enabled
3	OS3	0	R/W	Output Select 3 and 2
2	OS2	0	R/W	These bits specify how the TMOY pin output level is to be changed by compare-match B of TCORB_Y and TCNT_Y. 00: No change 01: 0 is output 10: 1 is output 11: Output is inverted (toggle output)
1	OS1	0	R/W	Output Select 1 and 0
0	OS0	0	R/W	These bits specify how the TMOY pin output level is to be changed by compare-match A of TCORA_Y and TCNT_Y. 00: No change 01: 0 is output 10: 1 is output 11: Output is inverted (toggle output)

Table: * Only 0 can be written, for flag clearing.

- TCSR_X

This register can be accessed when the KINWUE bit in SYSCR is 0 and the TMRX/Y bit in TCONRS is 0.

Bit	Bit Name	Initial Value	R/W	Description
7	CMFB	0	R/(W)*	Compare-Match Flag B [Setting condition] When the values of TCNT_X and TCORB_X match [Clearing condition] Read CMFB when CMFB = 1, then write 0 in CMFB
6	CMFA	0	R/(W)*	Compare-Match Flag A [Setting condition] When the values of TCNT_X and TCORA_X match [Clearing condition] Read CMFA when CMFA = 1, then write 0 in CMFA
5	OVF	0	R/(W)*	Timer Overflow Flag [Setting condition] When TCNT_X overflows from H'FF to H'00 [Clearing condition] Read OVF when OVF = 1, then write 0 in OVF
4	ICF	0	R/(W)*	Input Capture Flag [Setting condition] When a rising edge and falling edge is detected in the external reset signal in that order. [Clearing condition] Read ICF when ICF = 1, then write 0 in ICF
3	OS3	0	R/W	Output Select 3 and 2 These bits specify how the TMOX pin output level is to be changed by compare-match B of TCORB_X and TCNT_X. 00: No change 01: 0 is output 10: 1 is output 11: Output is inverted (toggle output)
2	OS2	0	R/W	

Bit	Bit Name	Initial Value	R/W	Description
1	OS1	0	R/W	Output Select 1 and 0
0	OS0	0	R/W	These bits specify how the TMOX pin output level is to be changed by compare-match A of TCORA_X and TCNT_X. 00: No change 01: 0 is output 10: 1 is output 11: Output is inverted (toggle output)

Note: * Only 0 can be written, for flag clearing.

12.3.6 Input Capture Register (TICR)

TICR is an 8-bit register. The contents of TCNT are transferred to TICR at the rising edge of the external reset input. TICR cannot be directly accessed by the CPU.

12.3.7 Time Constant Register C (TCORC)

TCORC is an 8-bit readable/writable register. The sum of contents of TCORC and TICR is always compared with TCNT. When a match is detected, a compare-match C signal is generated. However, comparison at the T2 state in the write cycle to TCORC and at the input capture cycle of TICR is disabled. TCORC is initialized to H'FF.

12.3.8 Input Capture Registers R and F (TICRR and TICRF)

TICRR and TICRF are 8-bit read-only registers. While the ICST bit in TCONRI is set to 1, the contents of TCNT are transferred at the rising edge and falling edge of the external reset input in that order. The ICST bit is cleared to 0 when one capture operation ends. TICRR and TICRF are initialized to H'00.

TICRR and TICRF can be accessed when the KINWUE bit in SYSCR is 0 and the TMRX/Y bit in TCONRS is 0. See section 3.2.2, System Control Register (SYSCR).

12.3.9 Timer Input Select Register (TISR)

TISR selects a signal source of external clock/reset input for the counter.

Bit	Bit Name	Initial Value	R/W	Description
7 to 1	—	All 1	R/W	Reserved The initial values should not be modified.
0	IS	0	R/W	Input Select Selects TMIY or ExTMIY as the signal source of external clock/reset input for the TMR_Y counter. When external reset input is selected for the CCLR0 and CCLR1 in TCR_Y or external clock is selected for the CKS2 to CKS0 in TCR_Y, set this bit to 1. 0: TMIY or ExTMIY (TMCY/TMRIY) is not selected 1: TMIY or ExTMIY (TMCY/TMRIY) is selected

12.3.10 Timer Connection Register I (TCONRI)

TCONRI controls TMR_X input capture.

Bit	Bit Name	Initial Value	R/W	Description
7 to 5	—	All 0	R/W	Reserved The initial values should not be modified.
4	ICST	0	R/W	Input Capture Start Bit TMR_X has input capture registers (TICR, TICRR, and TICRF). TICRR and TICRF can measure the width of a pulse by means of a single capture operation under the control of the ICST bit. When a rising edge followed by a falling edge is detected on TMRX after the ICST bit is set to 1, the contents of TCNT at those points are captured into TICRR and TICRF, respectively, and the ICST bit is cleared to 0. [Clearing condition] When a rising edge followed by a falling edge is detected on TMRX [Setting condition] When 1 is written in ICST after reading ICST = 0
3 to 0	—	All 0	R/W	Reserved The initial values should not be modified.

12.3.11 Timer Connection Register S (TCONRS)

TCONRS selects whether to access TMR_X or TMR_Y registers.

Bit	Bit Name	Initial Value	R/W	Description
7	TMRX/Y	0	R/W	TMR_X/TMR_Y Access Select For details, see table 12.3. 0: The TMR_X registers are accessed at addresses H'FFFFFF0 to H'FFFFFF5 1: The TMR_Y registers are accessed at addresses H'FFFFFF0 to H'FFFFFF5
6 to 0		All 0	R/W	Reserved The initial values should not be modified.

Table 12.3 Registers Accessible by TMR_X/TMR_Y

TMRX/Y	H'FFFFFF0	H'FFFFFF1	H'FFFFFF2	H'FFFFFF3	H'FFFFFF4	H'FFFFFF5	H'FFFFFF6	H'FFFFFF7
0	TMR_X	TMR_X	TMR_X	TMR_X	TMR_X	TMR_X	TMR_X	TMR_X
	TCR_X	TCSR_X	TICRR	TICRF	TCNT_X	TCORC	TCORA_X	TCORB_X
1	TMR_Y	TMR_Y	TMR_Y	TMR_Y	TMR_Y	TMR_Y		
	TCR_Y	TCSR_Y	TCORA_Y	TCORB_Y	TCNT_Y	TISR		

12.4 Operation

12.4.1 Pulse Output

Figure 12.3 shows an example for outputting an arbitrary duty pulse.

1. Clear the CCLR1 bit to 0 and set the CCLR0 bit to 1 in TCR so that TCNT is cleared according to the compare match of TCORA.
2. Set the OS3 to OS0 bits in TCSR to B'0110 so that 1 is output according to the compare match of TCORA and 0 is output according to the compare match of TCORB.

According to the above settings, the waveforms with the TCORA cycle and TCORB pulse width can be output without the intervention of software.

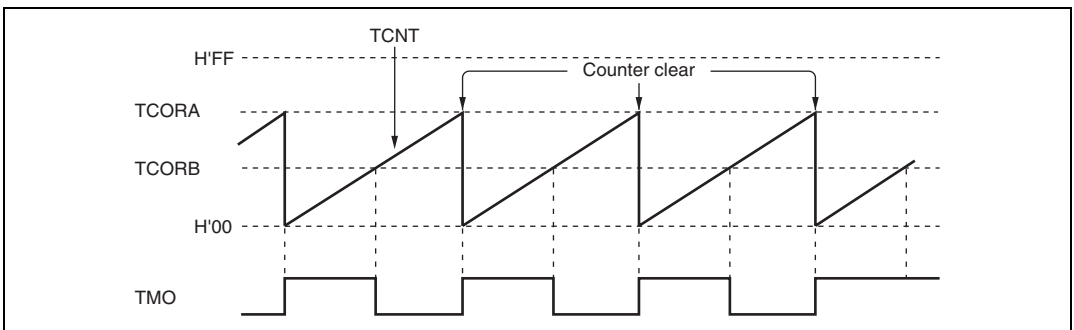

Figure 12.3 Pulse Output Example

12.5 Operation Timing

12.5.1 TCNT Count Timing

Figure 12.4 shows the TCNT count timing with an internal clock source. Figure 12.5 shows the TCNT count timing with an external clock source. The pulse width of the external clock signal must be at least 1.5 system clocks (ϕ) for a single edge and at least 2.5 system clocks (ϕ) for both edges. The counter will not increment correctly if the pulse width is less than these values.

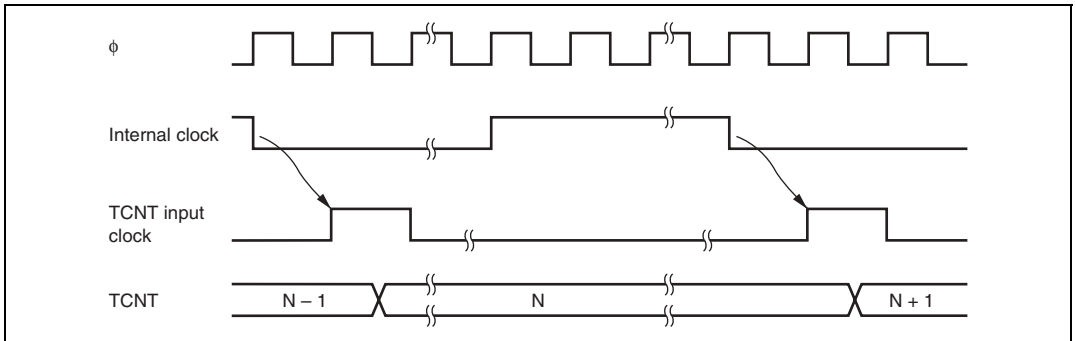

Figure 12.4 Count Timing for Internal Clock Input

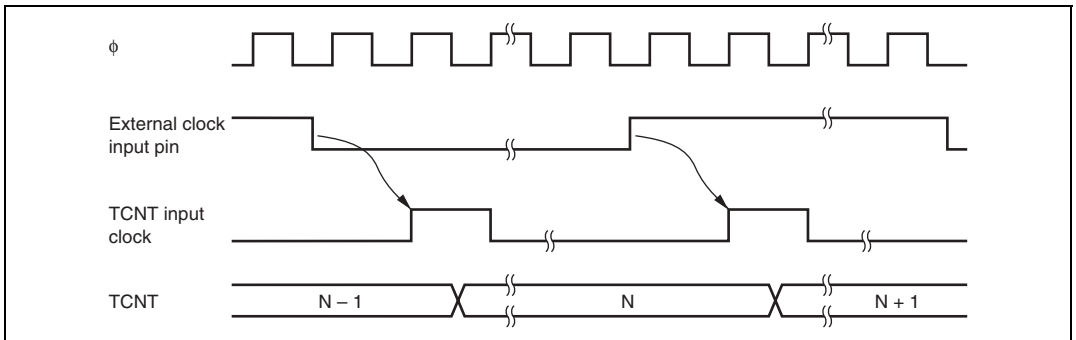

Figure 12.5 Count Timing for External Clock Input

12.5.2 Timing of CMFA and CMFB Setting at Compare-Match

The CMFA and CMFB flags in TCSR are set to 1 by a compare-match signal generated when the TCNT and TCOR values match. The compare-match signal is generated at the last state in which the match is true, just when the timer counter is updated. Therefore, when TCNT and TCOR match, the compare-match signal is not generated until the next TCNT input clock. Figure 12.6 shows the timing of CMF flag setting.

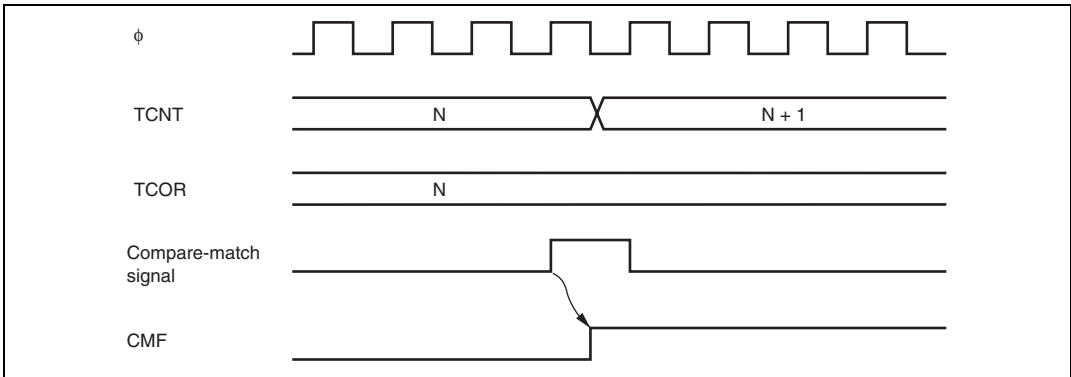

Figure 12.6 Timing of CMF Setting at Compare-Match

12.5.3 Timing of Timer Output at Compare-Match

When a compare-match signal occurs, the timer output changes as specified by the OS3 to OS0 bits in TCSR. Figure 12.7 shows the timing of timer output when the output is set to toggle by a compare-match A signal.

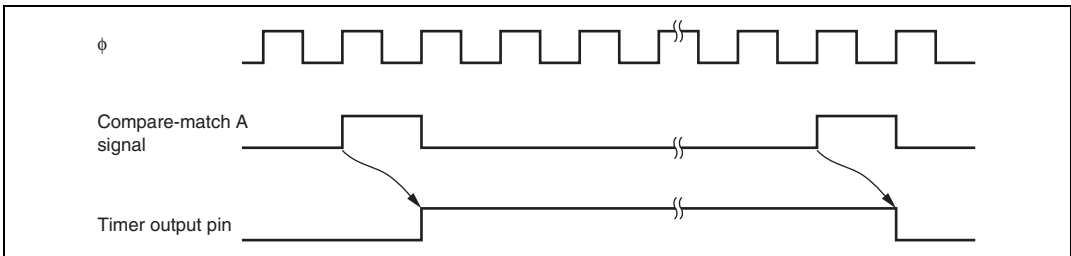

Figure 12.7 Timing of Toggled Timer Output by Compare-Match A Signal

12.5.4 Timing of Counter Clear at Compare-Match

TCNT is cleared when compare-match A or compare-match B occurs, depending on the setting of the CCLR1 and CCLR0 bits in TCR. Figure 12.8 shows the timing of clearing the counter by a compare-match.

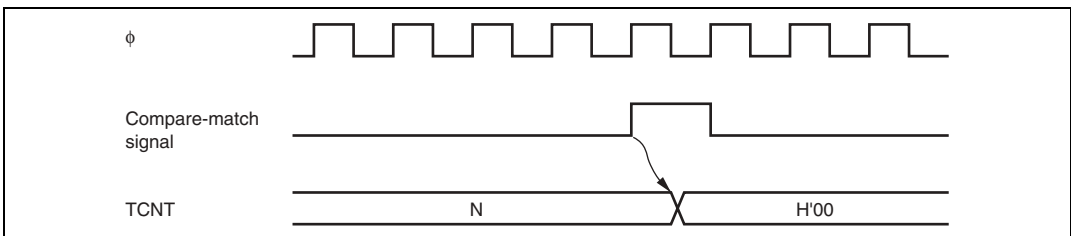

Figure 12.8 Timing of Counter Clear by Compare-Match

12.5.5 TCNT External Reset Timing

TCNT is cleared at the rising edge of an external reset input, depending on the settings of the CCLR1 and CCLR0 bits in TCR. The width of the clearing pulse must be at least 1.5 states. Figure 12.9 shows the timing of clearing the counter by an external reset input.

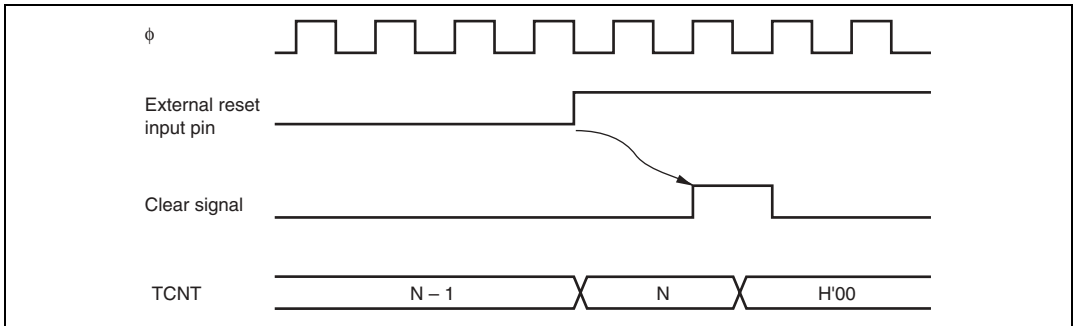

Figure 12.9 Timing of Counter Clear by External Reset Input

12.5.6 Timing of Overflow Flag (OVF) Setting

The OVF bit in TCSR is set to 1 when the TCNT overflows (changes from $H'FF$ to $H'00$). Figure 12.10 shows the timing of OVF flag setting.

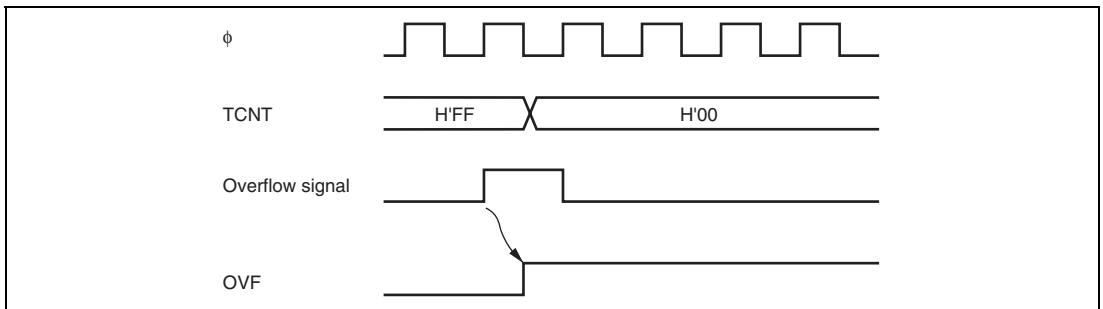

Figure 12.10 Timing of OVF Flag Setting

12.6 TMR_0 and TMR_1 Cascaded Connection

If bits CKS2 to CKS0 in either TCR_0 or TCR_1 are set to B'100, the 8-bit timers of the two channels are cascaded. With this configuration, 16-bit count mode or compare-match count mode can be selected.

12.6.1 16-Bit Count Mode

When bits CKS2 to CKS0 in TCR_0 are set to B'100, the timer functions as a single 16-bit timer with TMR_0 occupying the upper eight bits and TMR_1 occupying the lower eight bits.

- Setting of compare-match flags
 - The CMF flag in TCSR_0 is set to 1 when a 16-bit compare-match occurs.
 - The CMF flag in TCSR_1 is set to 1 when a lower 8-bit compare-match occurs.
- Counter clear specification
 - If the CCLR1 and CCLR0 bits in TCR_0 have been set for counter clear at compare-match, the 16-bit counter (TCNT_0 and TCNT_1 together) is cleared when a 16-bit compare-match occurs. The 16-bit counter (TCNT_0 and TCNT_1 together) is also cleared when counter clear by the TMI0 pin has been set.
 - The settings of the CCLR1 and CCLR0 bits in TCR_1 are ignored. The lower 8 bits cannot be cleared independently.
- Pin output
 - Control of output from the TMO0 pin by bits OS3 to OS0 in TCSR_0 is in accordance with the 16-bit compare-match conditions.
 - Control of output from the TMO1 pin by bits OS3 to OS0 in TCSR_1 is in accordance with the lower 8-bit compare-match conditions.

12.6.2 Compare-Match Count Mode

When bits CKS2 to CKS0 in TCR_1 are B'100, TCNT_1 counts the occurrence of compare-match A for TMR_0. TMR_0 and TMR_1 are controlled independently. Conditions such as setting of the CMF flag, generation of interrupts, output from the TMO pin, and counter clearing are in accordance with the settings for each channel.

12.7 Input Capture Operation

TMR_X has input capture registers (TICR, TICRR and TICRF). A narrow pulse width can be measured with TICRR and TICRF, using a single capture. If the falling edge of TMRIX (TMR_X input capture input signal) is detected after its rising edge has been detected, the value of TCNT_X at that time is transferred to both TICRR and TICRF.

Input Capture Signal Input Timing: Figure 12.11 shows the timing of the input capture operation.

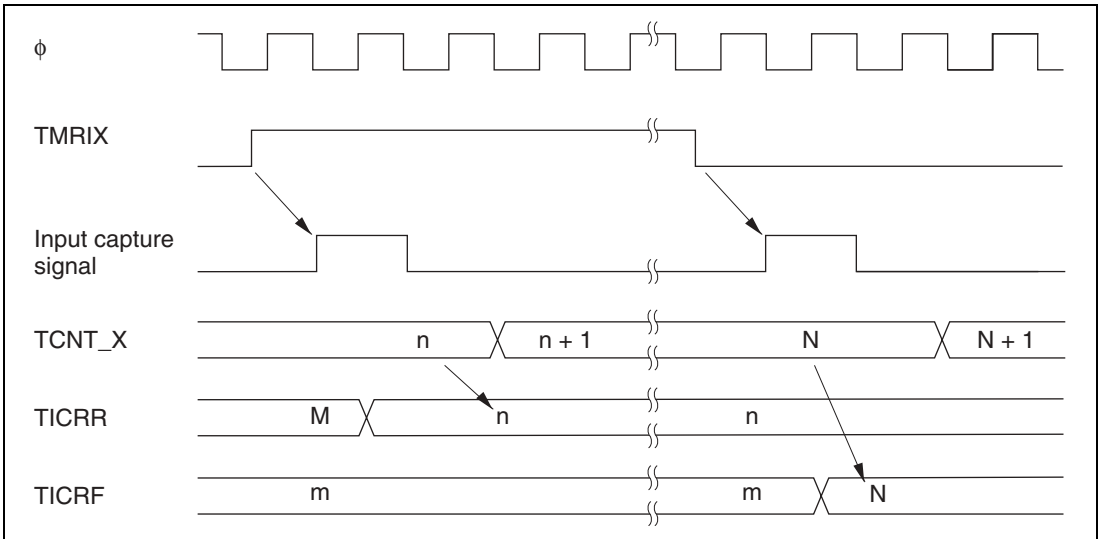

Figure 12.11 Timing of Input Capture Operation

If the input capture signal is input while TICRR and TICRF are being read, the input capture signal is delayed by one system clock (ϕ) cycle. Figure 12.12 shows the timing of this operation.

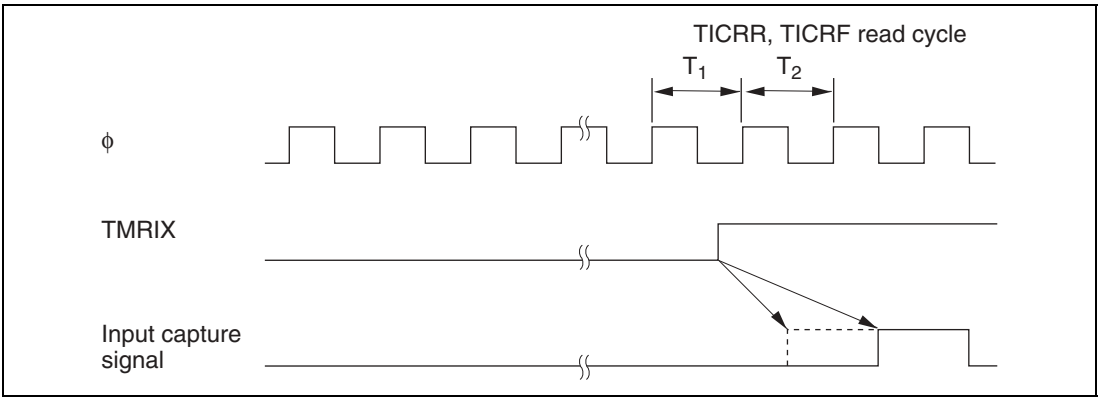

Figure 12.12 Timing of Input Capture Signal
(Input capture signal is input during TICRR and TICRF read)

Selection of Input Capture Signal Input: TMRX (input capture input signal of TMR_X) is switched according to the setting of the ICST bits in TCONR1. Input capture signal selections are shown in table 12.4.

Table 12.4 Input Capture Signal Selection

TCONR1

Bit 4

ICST	Description
0	Input capture function not used
1	TMUX pin input selection

12.8 Interrupt Sources

TMR_0, TMR_1, and TMR_Y can generate three types of interrupts: CMIA, CMIB, and OVI. TMR_X can generate four types of interrupts: CMIA, CMIB, OVI, and ICIX.

Table 12.5 shows the interrupt sources and priorities. Each interrupt source can be enabled or disabled independently by interrupt enable bits in TCR or TCSR. Independent signals are sent to the interrupt controller for each interrupt.

The CMIA and CMIB interrupts can be used as DTC activation interrupt sources.

Table 12.5 Interrupt Sources of 8-Bit Timers TMR_0, TMR_1, TMR_Y, and TMR_X

Channel	Name	Interrupt Source	Interrupt Flag	DTC Activation	Interrupt Priority
TMR_X	CMIA_X	TCORA_X compare-match	CMFA	Possible	High ↑ Low
	CMIB_X	TCORB_X compare-match	CMFB	Possible	
	OVI_X	TCNT_X overflow	OVF	Not possible	
	ICIX	Input capture	ICF	Not possible	
TMR_0	CMIA0	TCORA_0 compare-match	CMFA	Possible	
	CMIB0	TCORB_0 compare-match	CMFB	Possible	
	OVI0	TCNT_0 overflow	OVF	Not possible	
TMR_1	CMIA1	TCORA_1 compare-match	CMFA	Possible	
	CMIB1	TCORB_1 compare-match	CMFB	Possible	
	OVI1	TCNT_1 overflow	OVF	Not possible	
TMR_Y	CMIA_Y	TCORA_Y compare-match	CMFA	Possible	
	CMIB_Y	TCORB_Y compare-match	CMFB	Possible	
	OVI_Y	TCNT_Y overflow	OVF	Not possible	

12.9 Usage Notes

12.9.1 Conflict between TCNT Write and Counter Clear

If a counter clear signal is generated during the T_2 state of a TCNT write cycle as shown in figure 12.13, the counter clear takes priority and the write is not performed.

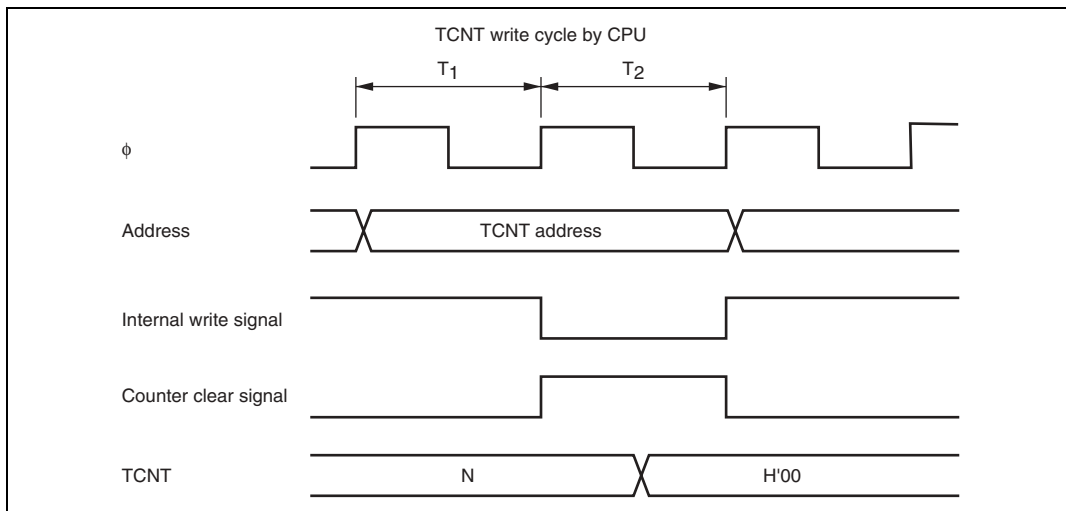

Figure 12.13 Conflict between TCNT Write and Counter Clear

12.9.2 Conflict between TCNT Write and Increment

If a TCNT input clock is generated during the T_2 state of a TCNT write cycle as shown in figure 12.14, the write takes priority and the counter is not incremented.

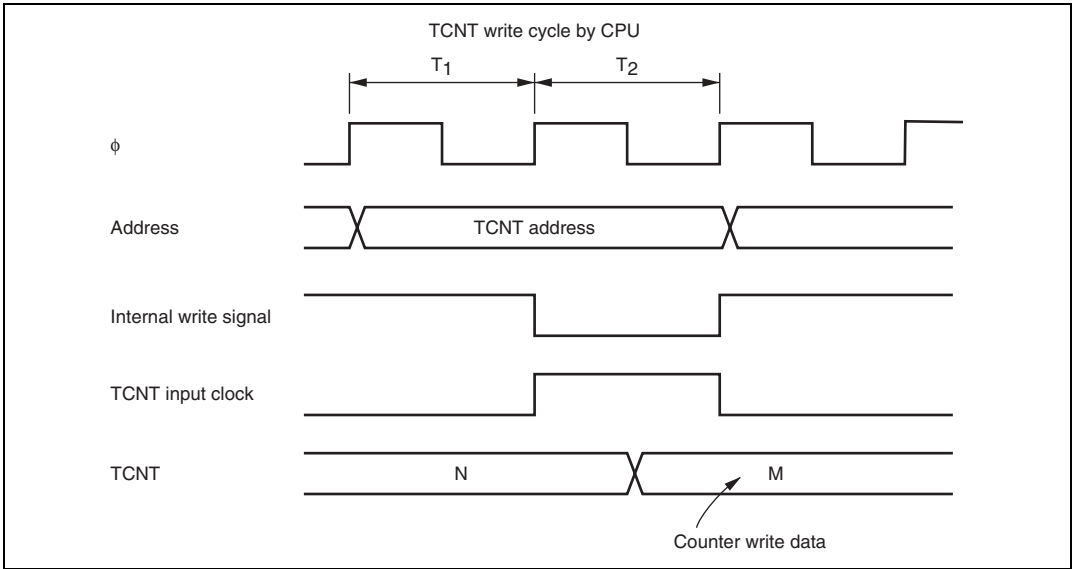

Figure 12.14 Conflict between TCNT Write and Increment

12.9.3 Conflict between TCOR Write and Compare-Match

If a compare-match occurs during the T_2 state of a TCOR write cycle as shown in figure 12.15, the TCOR write takes priority and the compare-match signal is disabled. With TMR_X, a T1CR input capture conflicts with a compare-match in the same way as with a write to TCORC. In this case also, the input capture takes priority and the compare-match signal is disabled.

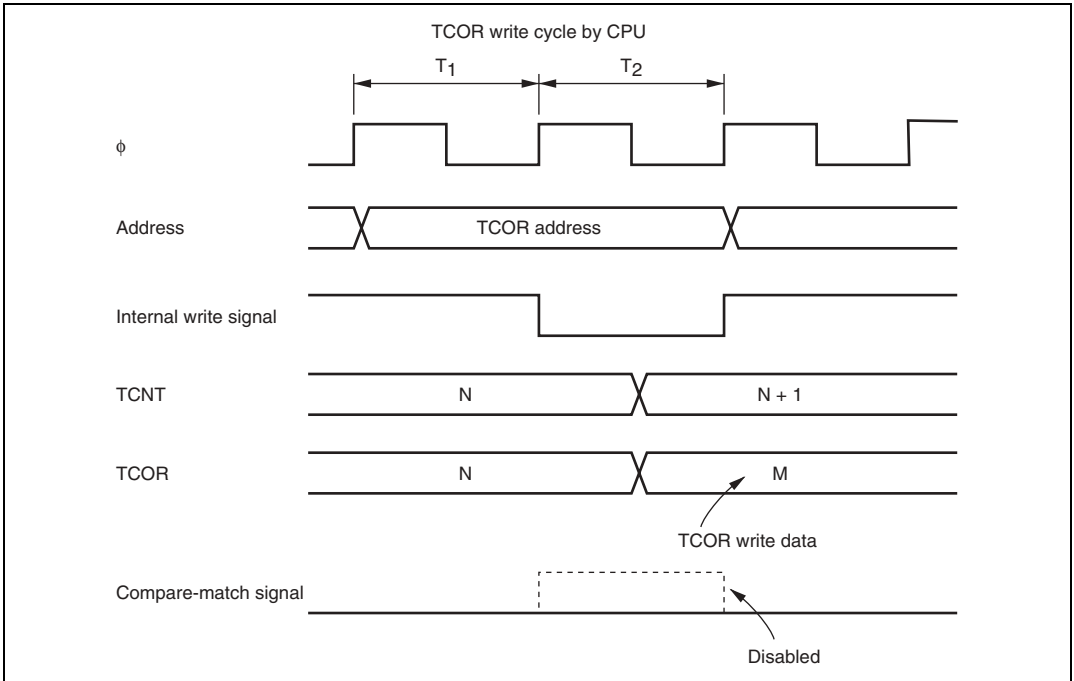

Figure 12.15 Conflict between TCOR Write and Compare-Match

12.9.4 Conflict between Compare-Matches A and B

If compare-matches A and B occur at the same time, the 8-bit timer operates in accordance with the priorities for the output states set for compare-match A and compare-match B, as shown in table 12.6.

Table 12.6 Timer Output Priorities

Output Setting	Priority
Toggle output	High
1 output	↑
0 output	
No change	Low

12.9.5 Switching of Internal Clocks and TCNT Operation

TCNT may increment erroneously when the internal clock is switched over. Table 12.7 shows the relationship between the timing at which the internal clock is switched (by writing to the CKS1 and CKS0 bits) and the TCNT operation.

When the TCNT clock is generated from an internal clock, the falling edge of the internal clock pulse is detected. If clock switching causes a change from high to low level, as shown in no. 3 in table 12.7, a TCNT clock pulse is generated on the assumption that the switchover is a falling edge, and TCNT is incremented.

Erroneous incrementation can also happen when switching between internal and external clocks.

Table 12.7 Switching of Internal Clocks and TCNT Operation

No.	Timing of Switchover by Means of CKS1 and CKS0 Bits	TCNT Clock Operation
1	Clock switching from low to low level* ¹	

Table 12.7 Switching of Internal Clocks and TCNT Operation (cont)

No.	Timing of Switchover by Means of CKS1 and CKS0 Bits	TCNT Clock Operation
2	Clock switching from low to high level* ²	
3	Clock switching from high to low level* ³	
4	Clock switching from high to high level	

- Notes:
1. Includes switching from low to stop, and from stop to low.
 2. Includes switching from stop to high.
 3. Includes switching from high to stop.
 4. Generated on the assumption that the switchover is a falling edge; TCNT is incremented.

12.9.6 Mode Setting with Cascaded Connection

If the 16-bit count mode and compare-match count mode are set simultaneously, the input clock pulses for TCNT_0 and TCNT_1 are not generated, and thus the counters will stop operating. Simultaneous setting of these two modes should therefore be avoided.

Section 13 Watchdog Timer (WDT)

This LSI incorporates two watchdog timer channels (WDT_0 and WDT_1). The watchdog timer can output an overflow signal ($\overline{\text{RESO}}$) externally if a system crash prevents the CPU from writing to the timer counter, thus allowing it to overflow. Simultaneously, it can generate an internal reset signal or an internal NMI interrupt signal.

When this watchdog function is not needed, the WDT can be used as an interval timer. In interval timer operation, an interval timer interrupt is generated each time the counter overflows. A block diagram of the WDT_0 and WDT_1 are shown in figure 13.1.

13.1 Features

- Selectable from eight (WDT_0) or 16 (WDT_1) counter input clocks.
- Switchable between watchdog timer mode and interval timer mode

Watchdog Timer Mode:

- If the counter overflows, an internal reset or an internal NMI interrupt is generated.
- When the LSI is selected to be internally reset at counter overflow, a low level signal is output from the $\overline{\text{RESO}}$ pin if the counter overflows.

Internal Timer Mode:

- If the counter overflows, an internal timer interrupt (WOVI) is generated.

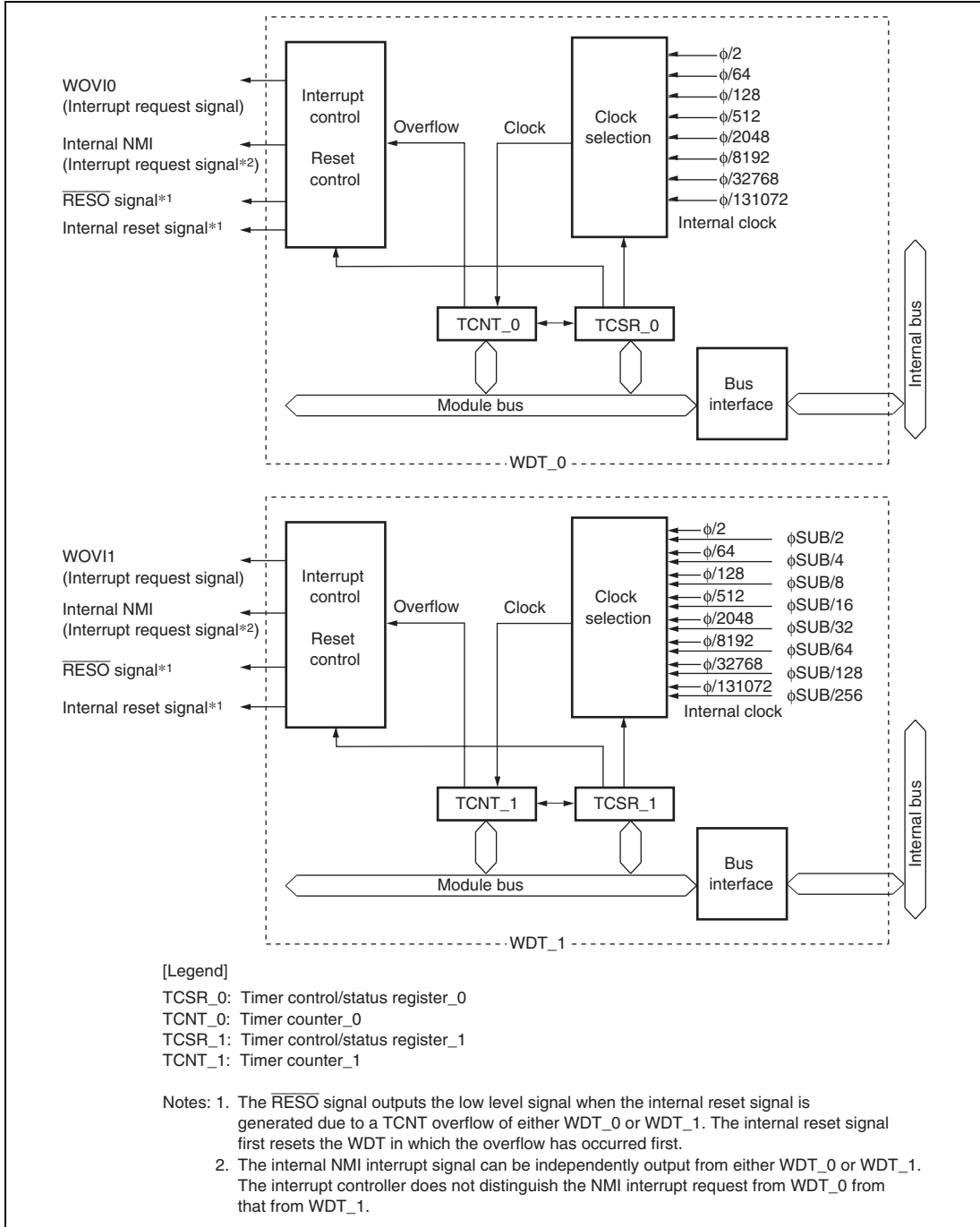

Figure 13.1 Block Diagram of WDT

13.2 Input/Output Pins

The WDT has the pins listed in table 13.1.

Table 13.1 Pin Configuration

Name	Symbol	I/O	Function
Reset output pin	$\overline{\text{RESO}}$	Output	Outputs the counter overflow signal in watchdog timer mode
External sub-clock input pin	EXCL	Input	Inputs the clock pulses to the WDT_1 prescaler counter

13.3 Register Descriptions

The WDT has the following registers. To prevent accidental overwriting, TCSR and TCNT have to be written to in a method different from normal registers. For details, see section 13.6.1, Notes on Register Access. For details on the system control register, see section 3.2.2, System Control Register (SYSCR).

- Timer counter (TCNT)
- Timer control/status register (TCSR)

13.3.1 Timer Counter (TCNT)

TCNT is an 8-bit readable/writable up-counter.

TCNT is initialized to H'00 when the TME bit in timer control/status register (TCSR) is cleared to 0.

13.3.2 Timer Control/Status Register (TCSR)

TCSR selects the clock source to be input to TCNT, and the timer mode.

- TCSR_0

Bit	Bit Name	Initial Value	R/W	Description
7	OVF	0	R/(W)*	<p>Overflow Flag</p> <p>Indicates that TCNT has overflowed (changes from H'FF to H'00).</p> <p>[Setting conditions]</p> <ul style="list-style-type: none">• When TCNT overflows (changes from H'FF to H'00)• When internal reset request generation is selected in watchdog timer mode, OVF is cleared automatically by the internal reset. <p>[Clearing conditions]</p> <ul style="list-style-type: none">• When TCSR is read when OVF = 1, then 0 is written to OVF• When 0 is written to TME
6	WT/ \bar{I} T	0	R/W	<p>Timer Mode Select</p> <p>Selects whether the WDT is used as a watchdog timer or interval timer.</p> <p>0: Interval timer mode 1: Watchdog timer mode</p>

Bit	Bit Name	Initial Value	R/W	Description
5	TME	0	R/W	<p>Timer Enable</p> <p>When this bit is set to 1, TCNT starts counting.</p> <p>When this bit is cleared, TCNT stops counting and is initialized to H'00.</p>
4	—	0	R/W	<p>Reserved</p> <p>The initial value should not be changed.</p>
3	RST/ $\overline{\text{NMI}}$	0	R/W	<p>Reset or NMI</p> <p>Selects to request an internal reset or an NMI interrupt when TCNT has overflowed.</p> <p>0: An NMI interrupt is requested</p> <p>1: An internal reset is requested</p>
2 to 0	CKS2 to CKS0	All 0	R/W	<p>Clock Select 2 to 0</p> <p>Select the clock source to be input to TCNT. The overflow frequency for $\phi = 33$ MHz is enclosed in parentheses.</p> <p>000: $\phi/2$ (frequency: 15.5 μs)</p> <p>001: $\phi/64$ (frequency: 496.5 μs)</p> <p>010: $\phi/128$ (frequency: 993.0 μs)</p> <p>011: $\phi/512$ (frequency: 4.0 ms)</p> <p>100: $\phi/2048$ (frequency: 15.9 ms)</p> <p>101: $\phi/8192$ (frequency: 63.6 ms)</p> <p>110: $\phi/32768$ (frequency: 254.2 ms)</p> <p>111: $\phi/131072$ (frequency: 1.02 s)</p>

Note: * Only 0 can be written, to clear the flag.

- TCSR_1

Bit	Bit Name	Initial Value	R/W	Description
7	OVF	0	R/(W)* ¹	<p>Overflow Flag</p> <p>Indicates that TCNT has overflowed (changes from H'FF to H'00).</p> <p>[Setting conditions]</p> <ul style="list-style-type: none"> • When TCNT overflows (changes from H'FF to H'00) • When internal reset request generation is selected in watchdog timer mode, OVF is cleared automatically by the internal reset. <p>[Clearing conditions]</p> <ul style="list-style-type: none"> • When TCSR is read when $OVF = 1^{*2}$, then 0 is written to OVF • When 0 is written to TME
6	WT/ \overline{IT}	0	R/W	<p>Timer Mode Select</p> <p>Selects whether the WDT is used as a watchdog timer or interval timer.</p> <p>0: Interval timer mode 1: Watchdog timer mode</p>
5	TME	0	R/W	<p>Timer Enable</p> <p>When this bit is set to 1, TCNT starts counting.</p> <p>When this bit is cleared, TCNT stops counting and is initialized to H'00.</p>
4	PSS	0	R/W	<p>Prescaler Select</p> <p>Selects the clock source to be input to TCNT.</p> <p>0: Counts the divided cycle of ϕ-based prescaler (PSM) 1: Counts the divided cycle of ϕSUB-based prescaler (PSS)</p>
3	RST/NMI	0	R/W	<p>Reset or NMI</p> <p>Selects to request an internal reset or an NMI interrupt when TCNT has overflowed.</p> <p>0: An NMI interrupt is requested 1: An internal reset is requested</p>

Bit	Bit Name	Initial Value	R/W	Description
2 to 0	CKS2 to CKS0	All 0	R/W	<p>Clock Select 2 to 0</p> <p>Select the clock source to be input to TCNT. The overflow cycle for $\phi = 33$ MHz and $\phi_{SUB} = 32.768$ kHz is enclosed in parentheses.</p> <p>When PSS = 0:</p> <p>000: $\phi/2$ (frequency: 15.5 μs) 001: $\phi/64$ (frequency: 496.5 μs) 010: $\phi/128$ (frequency: 993.0 μs) 011: $\phi/512$ (frequency: 4.0 ms) 100: $\phi/2048$ (frequency: 15.9 ms) 101: $\phi/8192$ (frequency: 63.6 ms) 110: $\phi/32768$ (frequency: 254.2 ms) 111: $\phi/131072$ (frequency: 1.02 s)</p> <p>When PSS = 1:</p> <p>000: $\phi_{SUB}/2$ (cycle: 15.6 ms) 001: $\phi_{SUB}/4$ (cycle: 31.3 ms) 010: $\phi_{SUB}/8$ (cycle: 62.5 ms) 011: $\phi_{SUB}/16$ (cycle: 125 ms) 100: $\phi_{SUB}/32$ (cycle: 250 ms) 101: $\phi_{SUB}/64$ (cycle: 500 ms) 110: $\phi_{SUB}/128$ (cycle: 1 s) 111: $\phi_{SUB}/256$ (cycle: 2 s)</p>

- Notes:
1. Only 0 can be written, to clear the flag.
 2. When OVF is polled with the interval timer interrupt disabled, OVF = 1 must be read at least twice.

13.4 Operation

13.4.1 Watchdog Timer Mode

To use the WDT as a watchdog timer, set the $\overline{WT/\overline{IT}}$ bit and the TME bit in TCSR to 1. While the WDT is used as a watchdog timer, if TCNT overflows without being rewritten because of a system malfunction or another error, an internal reset or NMI interrupt request is generated. TCNT does not overflow while the system is operating normally. Software must prevent TCNT overflows by rewriting the TCNT value (normally by writing H'00) before overflows occurs.

If the $\overline{RST/\overline{NMI}}$ bit of TCSR is set to 1, when the TCNT overflows, an internal reset signal for this LSI is issued for 518 system clocks, and the low level signal is simultaneously output from the $\overline{RES0}$ pin for 132 states, as shown in figure 13.2. If the $\overline{RST/\overline{NMI}}$ bit is cleared to 0, when the TCNT overflows, an NMI interrupt request is generated. Here, the output from the $\overline{RES0}$ pin remains high.

An internal reset request from the watchdog timer and a reset input from the \overline{RES} pin are processed in the same vector. Reset source can be identified by the XRST bit status in SYSCR. If a reset caused by a signal input to the \overline{RES} pin occurs at the same time as a reset caused by a WDT overflow, the \overline{RES} pin reset has priority and the XRST bit in SYSCR is set to 1.

An NMI interrupt request from the watchdog timer and an interrupt request from the NMI pin are processed in the same vector. Do not handle an NMI interrupt request from the watchdog timer and an interrupt request from the NMI pin at the same time.

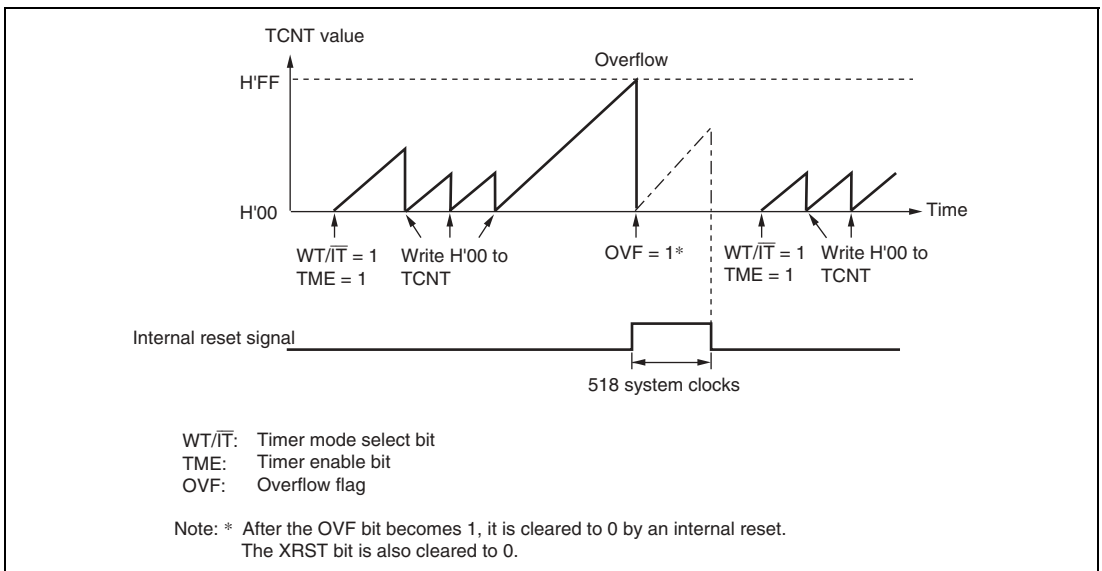

Figure 13.2 Watchdog Timer Mode ($\overline{RST/\overline{NMI}} = 1$) Operation

13.4.2 Interval Timer Mode

When the WDT is used as an interval timer, an interval timer interrupt (WOVI) is generated each time the TCNT overflows, as shown in figure 13.3. Therefore, an interrupt can be generated at intervals. When the TCNT overflows in interval timer mode, an interval timer interrupt (WOVI) is requested at the same time the OVF bit of TCSR is set to 1. The timing is shown figure 13.4.

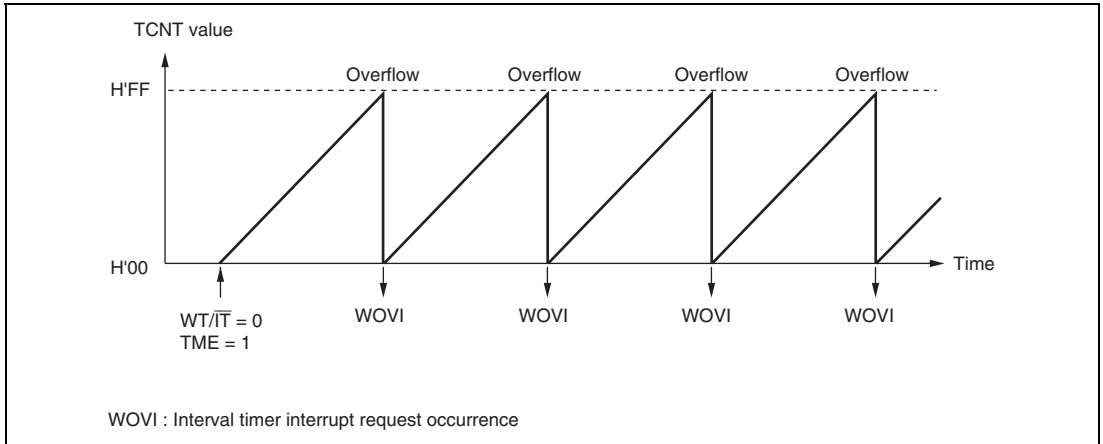

Figure 13.3 Interval Timer Mode Operation

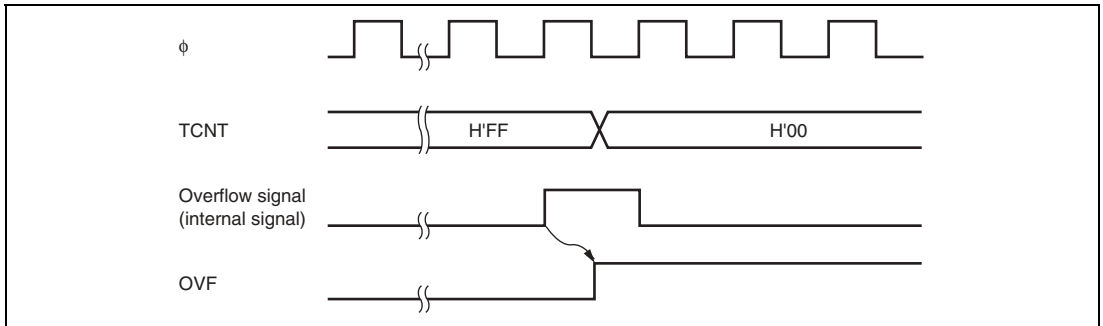

Figure 13.4 OVF Flag Set Timing

13.4.3 $\overline{\text{RESO}}$ Signal Output Timing

When TCNT overflows in watchdog timer mode, the OVF bit in TCSR is set to 1. When the RST/NMI bit is 1 here, the internal reset signal is generated for the entire LSI. At the same time, the low level signal is output from the $\overline{\text{RESO}}$ pin. The timing is shown in figure 13.5.

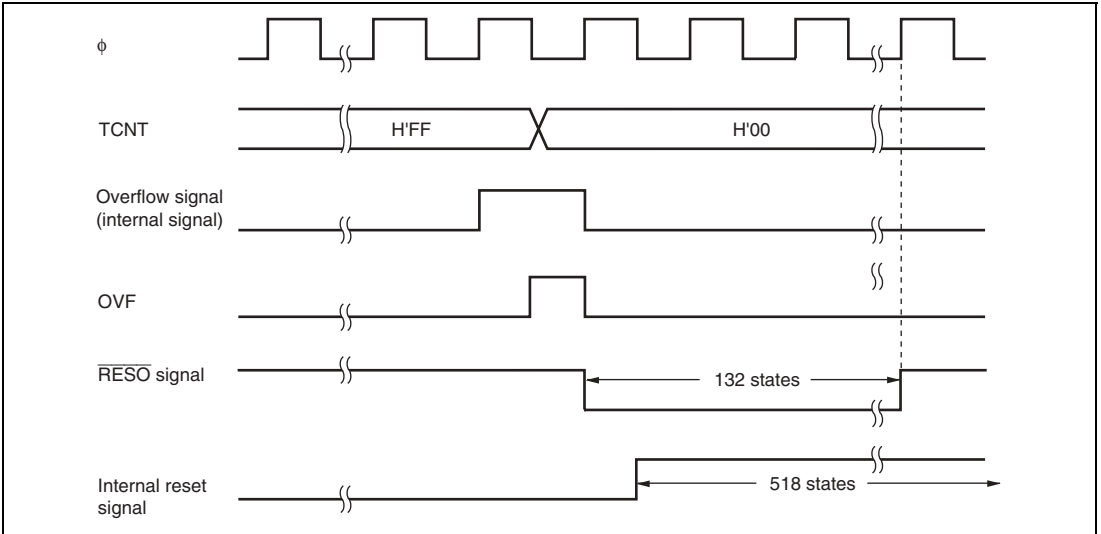

Figure 13.5 Output Timing of $\overline{\text{RESO}}$ signal

13.5 Interrupt Sources

During interval timer mode operation, an overflow generates an interval timer interrupt (WOVI). The interval timer interrupt is requested whenever the OVF flag is set to 1 in TCSR. OVF must be cleared to 0 in the interrupt handling routine.

When the NMI interrupt request is selected in watchdog timer mode, an NMI interrupt request is generated by an overflow

Table 13.2 WDT Interrupt Source

Name	Interrupt Source	Interrupt Flag	DTC Activation
WOVI	TCNT overflow	OVF	Not possible

13.6 Usage Notes

13.6.1 Notes on Register Access

The watchdog timer's registers, TCNT and TCSR differ from other registers in being more difficult to write to. The procedures for writing to and reading from these registers are given below.

Writing to TCNT and TCSR (Example of WDT_0):

These registers must be written to by a word transfer instruction. They cannot be written to by a byte transfer instruction.

TCNT and TCSR both have the same write address. Therefore, satisfy the relative condition shown in figure 13.6 to write to TCNT or TCSR. To write to TCNT, the higher bytes must contain the value H'5A and the lower bytes must contain the write data. To write to TCSR, the higher bytes must contain the value H'A5 and the lower bytes must contain the write data.

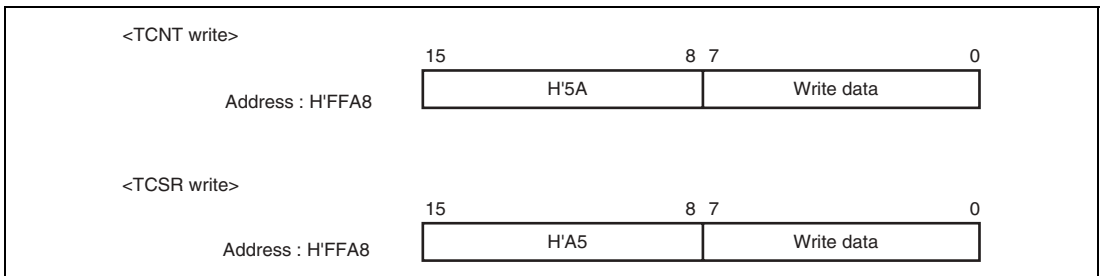

Figure 13.6 Writing to TCNT and TCSR (WDT_0)

Reading from TCNT and TCSR (Example of WDT_0):

These registers are read in the same way as other registers. The read address is H'FFA8 for TCSR and H'FFA9 for TCNT.

13.6.2 Conflict between Timer Counter (TCNT) Write and Increment

If a timer counter clock pulse is generated during the T_2 state of a TCNT write cycle, the write takes priority and the timer counter is not incremented. Figure 13.7 shows this operation.

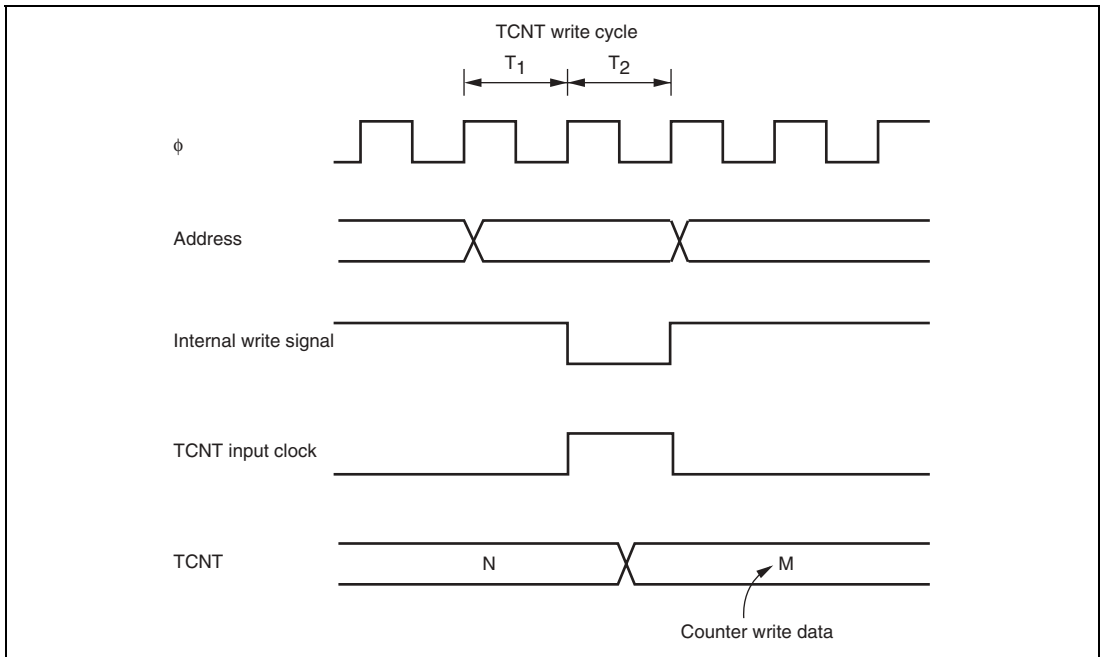

Figure 13.7 Conflict between TCNT Write and Increment

13.6.3 Changing Values of CKS2 to CKS0 Bits

If CKS2 to CKS0 bits in TCSR are written to while the WDT is operating, errors could occur in the incrementation. Software must stop the watchdog timer (by clearing the TME bit to 0) before changing the values of CKS2 to CKS0 bits.

13.6.4 Changing Value of PSS Bit

If the PSS bit in TCSR_1 is written to while the WDT is operating, errors could occur in the operation. Stop the watchdog timer (by clearing the TME bit to 0) before changing the values of PSS bit.

13.6.5 Switching between Watchdog Timer Mode and Interval Timer Mode

If the mode is switched from/to watchdog timer to/from interval timer, while the WDT is operating, errors could occur in the operation. Software must stop the watchdog timer (by clearing the TME bit to 0) before switching the mode.

13.6.6 System Reset by $\overline{\text{RESO}}$ Signal

Inputting the $\overline{\text{RESO}}$ output signal to the $\overline{\text{RES}}$ pin of this LSI prevents the LSI from being initialized correctly; the $\overline{\text{RESO}}$ signal must not be logically connected to the $\overline{\text{RES}}$ pin of the LSI. To reset the entire system by the $\overline{\text{RESO}}$ signal, use the circuit as shown in figure 13.8.

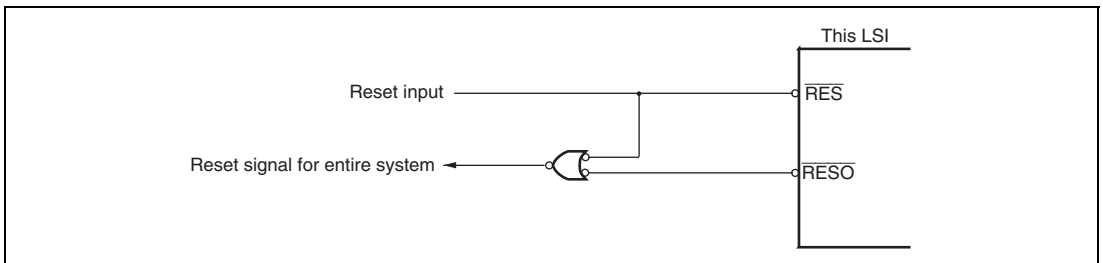

Figure 13.8 Sample Circuit for Resetting the System by the $\overline{\text{RESO}}$ Signal

Section 14 Serial Communication Interface (SCI, IrDA, and CRC)

This LSI has three independent serial communication interface (SCI) channels. The SCI can handle both asynchronous and clock synchronous serial communication. Asynchronous serial data communication can be carried out with standard asynchronous communication chips such as a Universal Asynchronous Receiver/Transmitter (UART) or Asynchronous Communication Interface Adapter (ACIA). A function is also provided for serial communication between processors (multiprocessor communication function). The SCI also supports the smart card (IC card) interface based on ISO/IEC 7816-3 (Identification Card) as an enhanced asynchronous communication function.

SCI_1 can handle communication using the waveform based on the Infrared Data Association (IrDA) standard version 1.0. SCI_0 and SCI_2 provide high-speed communication at an average transfer rate of a specific system clock frequency. Reliable fast data transfers are secured using the internal cyclic redundancy check (CRC) operation circuit. Since the CRC operation circuit is not connected to the SCI, data is transferred to the circuit using the MOV instruction to be operated there.

14.1 Features

- Choice of asynchronous or clock synchronous serial communication mode
- Full-duplex communication capability
The transmitter and receiver are mutually independent, enabling transmission and reception to be executed simultaneously. Double-buffering is used in both the transmitter and the receiver, enabling continuous transmission and continuous reception of serial data.
- On-chip baud rate generator allows any bit rate to be selected
The external clock can be selected as a transfer clock source (except for the smart card interface).
- Choice of LSB-first or MSB-first transfer (except in the case of asynchronous mode 7-bit data)
- Four interrupt sources
Four interrupt sources — transmit-end, transmit-data-empty, receive-data-full, and receive error — that can issue requests.
The transmit-data-empty and receive-data-full interrupt sources can activate DTC.
- Module stop mode availability

Asynchronous Mode:

- Data length: 7 or 8 bits
- Stop bit length: 1 or 2 bits
- Parity: Even, odd, or none
- Receive error detection: Parity, overrun, and framing errors
- Break detection: Break can be detected by reading the RxD pin level directly in case of a framing error
- Average transfer rate generator (SCI_0 and SCI_2): 460.606 kbps or 115.152 kbps selectable at 10.667-MHz operation; 720 kbps, 460.784 kbps, 230.392 kbps, or 115.196 kbps selectable at 16- or 24-MHz operation; 230.392 kbps or 115.196 kbps selectable at 20-MHz operation; and 720 kbps selectable at 32-MHz operation

Clock Synchronous Mode:

- Data length: 8 bits
- Receive error detection: Overrun errors
- SCI channel selectable (SCI_0 and SCI_2): When SSE0I = 1, TxD0 = high-impedance state and SCK0 = fixed to high input; when SSE2I = 1, TxD2 = high-impedance state and SCK2 = fixed to high input

Smart Card Interface:

- An error signal can be automatically transmitted on detection of a parity error during reception
- Data can be automatically re-transmitted on detection of a error signal during transmission
- Both direct convention and inverse convention are supported

Figure 14.1 shows a block diagram of SCI_1, and figure 14.2 shows a block diagram of SCI_0 and SCI_2.

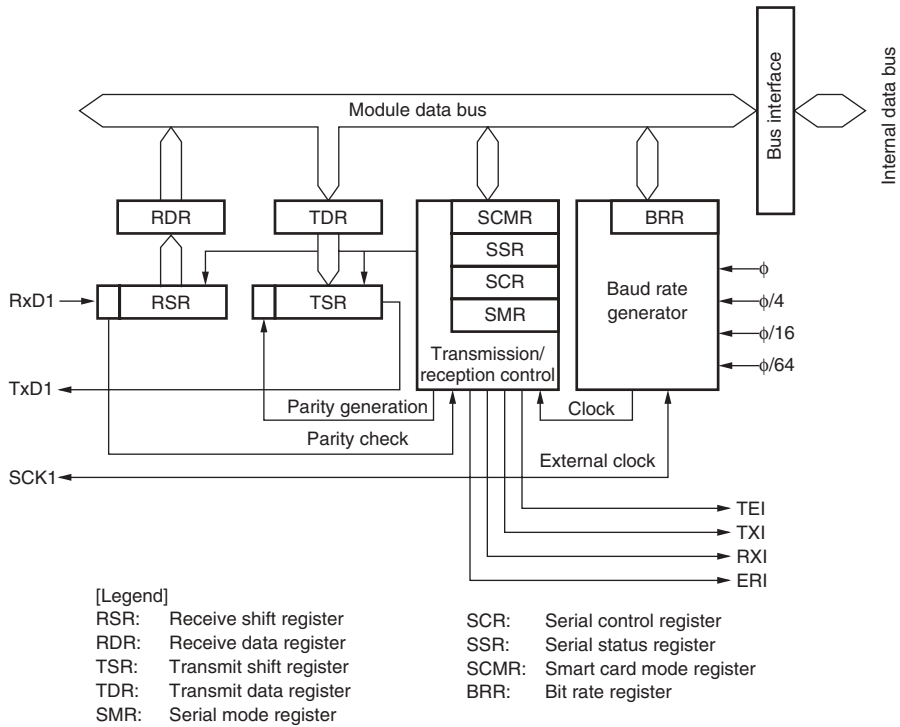

Figure 14.1 Block Diagram of SCI_1

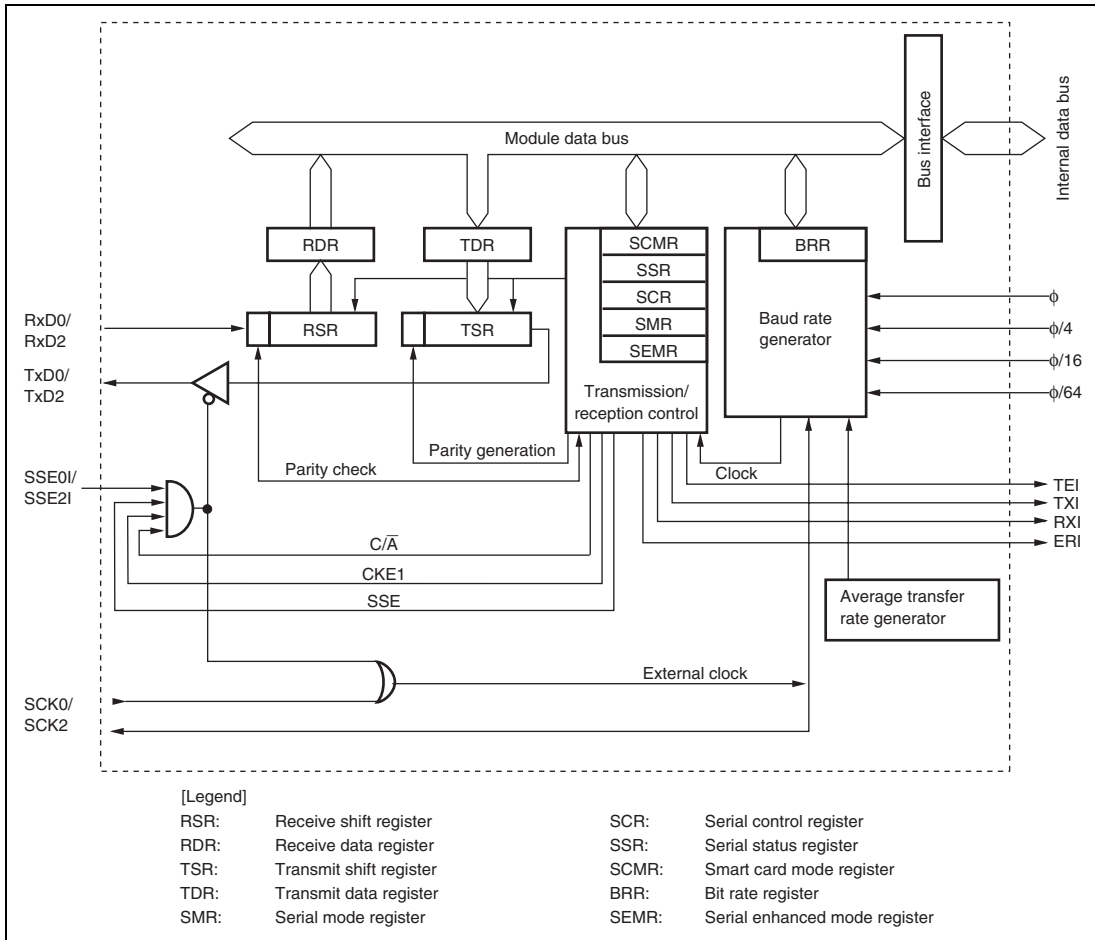

Figure 14.2 Block Diagram of SCI_0 and SCI_2

14.2 Input/Output Pins

Table 14.1 shows the input/output pins for each SCI channel.

Table 14.1 Pin Configuration

Channel	Symbol*	Input/Output	Function
0	SCK0	Input/Output	Channel 0 clock input/output
	RxD0	Input	Channel 0 receive data input
	TxD0	Output	Channel 0 transmit data output
	SSE0I	Input	Channel 0 stop input
1	SCK1	Input/Output	Channel 1 clock input/output
	RxD1/IrRxD	Input	Channel 1 receive data input (normal/IrDA)
	TxD1/IrTxD	Output	Channel 1 transmit data output (normal/IrDA)
2	SCK2	Input/Output	Channel 2 clock input/output
	RxD2	Input	Channel 2 receive data input
	TxD2	Output	Channel 2 transmit data output
	SSE2I	Input	Channel 2 stop input

Note: * Pin names SCK, RxD, and TxD are used in the text for all channels, omitting the channel designation.

14.3 Register Descriptions

The SCI has the following registers for each channel. Some bits in the serial mode register (SMR), serial status register (SSR), and serial control register (SCR) have different functions in different modes—normal serial communication interface mode and smart card interface mode; therefore, the bits are described separately for each mode in the corresponding register sections. . The SCI registers are allocated to the same address. Selecting register is carried out by means of the IICE bit in the serial timer control register (STCR).

- Receive shift register (RSR)
- Receive data register (RDR)
- Transmit data register (TDR)
- Transmit shift register (TSR)
- Serial mode register (SMR)
- Serial control register (SCR)
- Serial status register (SSR)
- Smart card mode register (SCMR)
- Bit rate register (BRR)
- Serial interface control register (SCICR)*¹
- Serial enhanced mode register (SEMR)*²

Notes: 1. SCICR is not available in SCI_0 or SCI_2.
2. SEMR is not available in SCI_1.

14.3.1 Receive Shift Register (RSR)

RSR is a shift register used to receive serial data that converts it into parallel data. When one frame of data has been received, it is transferred to RDR automatically. RSR cannot be directly accessed by the CPU.

14.3.2 Receive Data Register (RDR)

RDR is an 8-bit register that stores receive data. When the SCI has received one frame of serial data, it transfers the received serial data from RSR to RDR where it is stored. After this, RSR can receive the next data. Since RSR and RDR function as a double buffer in this way, continuous receive operations be performed. After confirming that the RDRF bit in SSR is set to 1, read RDR for only once. RDR cannot be written to by the CPU.

14.3.3 Transmit Data Register (TDR)

TDR is an 8-bit register that stores transmit data. When the SCI detects that TSR is empty, it transfers the transmit data written in TDR to TSR and starts transmission. The double-buffered structures of TDR and TSR enables continuous serial transmission. If the next transmit data has already been written to TDR when one frame of data is transmitted, the SCI transfers the written data to TSR to continue transmission. Although TDR can be read from or written to by the CPU at all times, to achieve reliable serial transmission, write transmit data to TDR for only once after confirming that the TDRE bit in SSR is set to 1.

14.3.4 Transmit Shift Register (TSR)

TSR is a shift register that transmits serial data. To perform serial data transmission, the SCI first transfers transmit data from TDR to TSR, then sends the data to the TxD pin. TSR cannot be directly accessed by the CPU.

14.3.5 Serial Mode Register (SMR)

SMR is used to set the SCI's serial transfer format and select the baud rate generator clock source. Some bits in SMR have different functions in normal mode and smart card interface mode.

- Bit Functions in Normal Serial Communication Interface Mode (when SMIF in SCMR = 0)

Bit	Bit Name	Initial Value	R/W	Description
7	C/ \bar{A}	0	R/W	Communication Mode 0: Asynchronous mode 1: Clock synchronous mode
6	CHR	0	R/W	Character Length (enabled only in asynchronous mode) 0: Selects 8 bits as the data length. 1: Selects 7 bits as the data length. LSB-first is fixed and the MSB of TDR is not transmitted in transmission. In clock synchronous mode, a fixed data length of 8 bits is used.
5	PE	0	R/W	Parity Enable (enabled only in asynchronous mode) When this bit is set to 1, the parity bit is added to transmit data before transmission, and the parity bit is checked in reception. For a multiprocessor format, parity bit addition and checking are not performed regardless of the PE bit setting.
4	O/ \bar{E}	0	R/W	Parity Mode (enabled only when the PE bit is 1 in asynchronous mode) 0: Selects even parity. 1: Selects odd parity.
3	STOP	0	R/W	Stop Bit Length (enabled only in asynchronous mode) Selects the stop bit length in transmission. 0: 1 stop bit 1: 2 stop bits In reception, only the first stop bit is checked. If the second stop bit is 0, it is treated as the start bit of the next transmit frame.
2	MP	0	R/W	Multiprocessor Mode (enabled only in asynchronous mode) When this bit is set to 1, the multiprocessor communication function is enabled. The PE bit and O/E bit settings are invalid in multiprocessor mode.

Bit	Bit Name	Initial Value	R/W	Description
1	CKS1	0	R/W	Clock Select 1 and 0
0	CKS0	0	R/W	<p>These bits select the clock source for the baud rate generator.</p> <p>00: ϕ clock ($n = 0$)</p> <p>01: $\phi/4$ clock ($n = 1$)</p> <p>10: $\phi/16$ clock ($n = 2$)</p> <p>11: $\phi/64$ clock ($n = 3$)</p> <p>For the relation between the bit rate register setting and the baud rate, see section 14.3.9, Bit Rate Register (BRR). n is the decimal display of the value of n in BRR (see section 14.3.9, Bit Rate Register (BRR)).</p>

- Bit Functions in Smart Card Interface Mode (when SMIF in SCMR = 1)

Bit	Bit Name	Initial Value	R/W	Description
7	GM	0	R/W	<p>GSM Mode</p> <p>Setting this bit to 1 allows GSM mode operation. In GSM mode, the TEND set timing is put forward to 11.0 etu* from the start and the clock output control function is appended. For details, see section 14.7.8, Clock Output Control.</p>
6	BLK	0	R/W	<p>Setting this bit to 1 allows block transfer mode operation. For details, see section 14.7.3, Block Transfer Mode.</p>
5	PE	0	R/W	<p>Parity Enable (valid only in asynchronous mode)</p> <p>When this bit is set to 1, the parity bit is added to transmit data before transmission, and the parity bit is checked in reception. Set this bit to 1 in smart card interface mode.</p>
4	O/E	0	R/W	<p>Parity Mode (valid only when the PE bit is 1 in asynchronous mode)</p> <p>0: Selects even parity</p> <p>1: Selects odd parity</p> <p>For details on the usage of this bit in smart card interface mode, see section 14.7.2, Data Format (Except in Block Transfer Mode).</p>

Bit	Bit Name	Initial Value	R/W	Description
3	BCP1	0	R/W	Basic Clock Pulse 1 and 0
2	BCP0	0	R/W	<p>These bits select the number of basic clock cycles in a 1-bit data transfer time in smart card interface mode.</p> <p>00: 32 clock cycles (S = 32)</p> <p>01: 64 clock cycles (S = 64)</p> <p>10: 372 clock cycles (S = 372)</p> <p>11: 256 clock cycles (S = 256)</p> <p>For details, see section 14.7.4, Receive Data Sampling Timing and Reception Margin. S is described in section 14.3.9, Bit Rate Register (BRR).</p>
1	CKS1	0	R/W	Clock Select 1 and 0
0	CKS0	0	R/W	<p>These bits select the clock source for the baud rate generator.</p> <p>00: ϕ clock (n = 0)</p> <p>01: $\phi/4$ clock (n = 1)</p> <p>10: $\phi/16$ clock (n = 2)</p> <p>11: $\phi/64$ clock (n = 3)</p> <p>For the relation between the bit rate register setting and the baud rate, see section 14.3.9, Bit Rate Register (BRR). n is the decimal display of the value of n in BRR (see section 14.3.9, Bit Rate Register (BRR)).</p>

Note: * etu: Element Time Unit (time taken to transfer one bit)

14.3.6 Serial Control Register (SCR)

SCR is a register that performs enabling or disabling of SCI transfer operations and interrupt requests, and selection of the transfer clock source. For details on interrupt requests, see section 14.9, Interrupt Sources. Some bits in SCR have different functions in normal mode and smart card interface mode.

- Bit Functions in Normal Serial Communication Interface Mode (when SMIF in SCMR = 0)

Bit	Bit Name	Initial Value	R/W	Description
7	TIE	0	R/W	Transmit Interrupt Enable When this bit is set to 1, a TXI interrupt request is enabled.
6	RIE	0	R/W	Receive Interrupt Enable When this bit is set to 1, RXI and ERI interrupt requests are enabled.
5	TE	0	R/W	Transmit Enable When this bit is set to 1, transmission is enabled.
4	RE	0	R/W	Receive Enable When this bit is set to 1, reception is enabled.
3	MPIE	0	R/W	Multiprocessor Interrupt Enable (enabled only when the MP bit in SMR is 1 in asynchronous mode) When this bit is set to 1, receive data in which the multiprocessor bit is 0 is skipped, and setting of the RDRF, FER, and ORER status flags in SSR is disabled. On receiving data in which the multiprocessor bit is 1, this bit is automatically cleared and normal reception is resumed. For details, see section 14.5, Multiprocessor Communication Function.
2	TEIE	0	R/W	Transmit End Interrupt Enable When this bit is set to 1, a TEI interrupt request is enabled.

Bit	Bit Name	Initial Value	R/W	Description
1	CKE1	0	R/W	Clock Enable 1 and 0
0	CKE0	0	R/W	<p>These bits select the clock source and SCK pin function.</p> <p>Asynchronous mode:</p> <p>00: Internal clock (SCK pin functions as I/O port.)</p> <p>01: Internal clock (Outputs a clock of the same frequency as the bit rate from the SCK pin.)</p> <p>1*: External clock (Inputs a clock with a frequency 16 times the bit rate from the SCK pin.)</p> <p>Clock synchronous mode:</p> <p>0*: Internal clock (SCK pin functions as clock output.)</p> <p>1*: External clock (SCK pin functions as clock input.)</p>

[Legend]

*: Don't care

- Bit Functions in Smart Card Interface Mode (when SMIF in SCMR = 1)

Bit	Bit Name	Initial Value	R/W	Description
7	TIE	0	R/W	Transmit Interrupt Enable When this bit is set to 1, a TXI interrupt request is enabled.
6	RIE	0	R/W	Receive Interrupt Enable When this bit is set to 1, RXI and ERI interrupt requests are enabled.
5	TE	0	R/W	Transmit Enable When this bit is set to 1, transmission is enabled.
4	RE	0	R/W	Receive Enable When this bit is set to 1, reception is enabled.
3	MPIE	0	R/W	Multiprocessor Interrupt Enable (enabled only when the MP bit in SMR is 1 in asynchronous mode) Write 0 to this bit in smart card interface mode.
2	TEIE	0	R/W	Transmit End Interrupt Enable Write 0 to this bit in smart card interface mode.
1	CKE1	0	R/W	Clock Enable 1 and 0
0	CKE0	0	R/W	These bits control the clock output from the SCK pin. In GSM mode, clock output can be dynamically switched. For details, see section 14.7.8, Clock Output Control. When GM in SMR = 0 00: Output disabled (SCK pin functions as I/O port.) 01: Clock output 1*: Reserved When GM in SMR = 1 00: Output fixed to low 01: Clock output 10: Output fixed to high 11: Clock output

[Legend]

*: Don't care.

14.3.7 Serial Status Register (SSR)

SSR is a register containing status flags of the SCI and multiprocessor bits for transfer. TDRE, RDRF, ORER, PER, and FER can only be cleared. Some bits in SSR have different functions in normal mode and smart card interface mode.

- Bit Functions in Normal Serial Communication Interface Mode (when SMIF in SCMR = 0)

Bit	Bit Name	Initial Value	R/W	Description
7	TDRE	1	R/(W)*	<p>Transmit Data Register Empty</p> <p>Indicates whether TDR contains transmit data.</p> <p>[Setting conditions]</p> <ul style="list-style-type: none"> • When the TE bit in SCR is 0 • When data is transferred from TDR to TSR and TDR is ready for data write <p>[Clearing conditions]</p> <ul style="list-style-type: none"> • When 0 is written to TDRE after reading TDRE = 1 • When a TXI interrupt request is issued allowing DTC to write data to TDR
6	RDRF	0	R/(W)*	<p>Receive Data Register Full</p> <p>Indicates that receive data is stored in RDR.</p> <p>[Setting condition]</p> <ul style="list-style-type: none"> • When serial reception ends normally and receive data is transferred from RSR to RDR <p>[Clearing conditions]</p> <ul style="list-style-type: none"> • When 0 is written to RDRF after reading RDRF = 1 • When an RXI interrupt request is issued allowing DTC to read data from RDR <p>The RDRF flag is not affected and retains its previous value when the RE bit in SCR is cleared to 0.</p>

Bit	Bit Name	Initial Value	R/W	Description
5	ORER	0	R/(W)*	<p>Overrun Error</p> <p>[Setting condition]</p> <p>When the next serial reception is completed while RDRF = 1</p> <p>[Clearing condition]</p> <p>When 0 is written to ORER after reading ORER = 1</p>
4	FER	0	R/(W)*	<p>Framing Error</p> <p>[Setting condition]</p> <p>When the stop bit is 0</p> <p>[Clearing condition]</p> <p>When 0 is written to FER after reading FER = 1</p> <p>In 2-stop-bit mode, only the first stop bit is checked.</p>
3	PER	0	R/(W)*	<p>Parity Error</p> <p>[Setting condition]</p> <p>When a parity error is detected during reception</p> <p>[Clearing condition]</p> <p>When 0 is written to PER after reading PER = 1</p>
2	TEND	1	R	<p>Transmit End</p> <p>[Setting conditions]</p> <ul style="list-style-type: none"> • When the TE bit in SCR is 0 • When TDRE = 1 at transmission of the last bit of a 1-byte serial transmit character <p>[Clearing conditions]</p> <ul style="list-style-type: none"> • When 0 is written to TDRE after reading TDRE = 1 • When a TXI interrupt request is issued allowing DTC to write data to TDR
1	MPB	0	R	<p>Multiprocessor Bit</p> <p>MPB stores the multiprocessor bit in the receive frame. When the RE bit in SCR is cleared to 0 its previous state is retained.</p>
0	MPBT	0	R/W	<p>Multiprocessor Bit Transfer</p> <p>MPBT stores the multiprocessor bit to be added to the transmit frame.</p>

Note: * Only 0 can be written, to clear the flag.

- Bit Functions in Smart Card Interface Mode (when SMIF in SCMR = 1)

Bit	Bit Name	Initial Value	R/W	Description
7	TDRE	1	R/(W)*	<p>Transmit Data Register Empty</p> <p>Indicates whether TDR contains transmit data.</p> <p>[Setting conditions]</p> <ul style="list-style-type: none"> • When the TE bit in SCR is 0 • When data is transferred from TDR to TSR, and TDR can be written to. <p>[Clearing conditions]</p> <ul style="list-style-type: none"> • When 0 is written to TDRE after reading TDRE = 1 • When a TXI interrupt request is issued allowing DTC to write data to TDR
6	RDRF	0	R/(W)* ¹	<p>Receive Data Register Full</p> <p>Indicates that receive data is stored in RDR.</p> <p>[Setting condition]</p> <ul style="list-style-type: none"> • When serial reception ends normally and receive data is transferred from RSR to RDR <p>[Clearing conditions]</p> <ul style="list-style-type: none"> • When 0 is written to RDRF after reading RDRF = 1 • When an RXI interrupt request is issued allowing DTC to read data from RDR <p>The RDRF flag is not affected and retains its previous value when the RE bit in SCR is cleared to 0.</p>
5	ORER	0	R/(W)* ¹	<p>Overrun Error</p> <p>[Setting condition]</p> <p>When the next serial reception is completed while RDRF = 1</p> <p>[Clearing condition]</p> <p>When 0 is written to ORER after reading ORER = 1</p>
4	ERS	0	R/(W)* ¹	<p>Error Signal Status</p> <p>[Setting condition]</p> <p>When a low error signal is sampled</p> <p>[Clearing condition]</p> <p>When 0 is written to ERS after reading ERS = 1</p>

Bit	Bit Name	Initial Value	R/W	Description
3	PER	0	R/(W)* ¹	Parity Error [Setting condition] When a parity error is detected during reception [Clearing condition] When 0 is written to PER after reading PER = 1
2	TEND	1	R	Transmit End TEND is set to 1 when the receiving end acknowledges no error signal and the next transmit data is ready to be transferred to TDR. [Setting conditions] <ul style="list-style-type: none"> • When both TE in SCR and ERS are 0 • When ERS = 0 and TDRE = 1 after a specified time passed after the start of 1-byte data transfer. The set timing depends on the register setting as follows. When GM = 0 and BLK = 0, 2.5 etu*² after transmission start When GM = 0 and BLK = 1, 1.5 etu*² after transmission start When GM = 1 and BLK = 0, 1.0 etu*² after transmission start When GM = 1 and BLK = 1, 1.0 etu*² after transmission start [Clearing conditions] <ul style="list-style-type: none"> • When 0 is written to TDRE after reading TDRE = 1 • When a TXI interrupt request is issued allowing DTC to write the next data to TDR
1	MPB	0	R	Multiprocessor Bit Not used in smart card interface mode.
0	MPBT	0	R/W	Multiprocessor Bit Transfer Write 0 to this bit in smart card interface mode.

Notes: 1. Only 0 can be written, to clear the flag.

2. etu: Element Time Unit (time taken to transfer one bit)

14.3.8 Smart Card Mode Register (SCMR)

SCMR selects smart card interface mode and its format.

Bit	Bit Name	Initial Value	R/W	Description
7 to 4	—	All 1	R	Reserved These bits are always read as 1 and cannot be modified.
3	SDIR	0	R/W	Smart Card Data Transfer Direction Selects the serial/parallel conversion format. 0: TDR contents are transmitted with LSB-first. Stores receive data as LSB first in RDR. 1: TDR contents are transmitted with MSB-first. Stores receive data as MSB first in RDR. The SDIR bit is valid only when the 8-bit data format is used for transmission/reception; when the 7-bit data format is used, data is always transmitted/received with LSB-first.
2	SINV	0	R/W	Smart Card Data Invert Specifies inversion of the data logic level. The SINV bit does not affect the logic level of the parity bit. When the parity bit is inverted, invert the O/\bar{E} bit in SMR. 0: TDR contents are transmitted as they are. Receive data is stored as it is in RDR. 1: TDR contents are inverted before being transmitted. Receive data is stored in inverted form in RDR.
1	—	1	R	Reserved This bit is always read as 1 and cannot be modified.
0	SMIF	0	R/W	Smart Card Interface Mode Select When this bit is set to 1, smart card interface mode is selected. 0: Normal asynchronous or clock synchronous mode 1: Smart card interface mode

14.3.9 Bit Rate Register (BRR)

BRR is an 8-bit register that adjusts the bit rate. As the SCI performs baud rate generator control independently for each channel, different bit rates can be set for each channel. Table 14.2 shows the relationships between the N setting in BRR and bit rate B for normal asynchronous mode and clock synchronous mode, and smart card interface mode. The initial value of BRR is H'FF, and it can be read from or written to by the CPU at all times.

Table 14.2 Relationships between N Setting in BRR and Bit Rate B

Mode	Bit Rate	Error
Asynchronous mode	$B = \frac{\phi \times 10^6}{64 \times 2^{2n-1} \times (N+1)}$	$\text{Error (\%)} = \left\{ \frac{\phi \times 10^6}{B \times 64 \times 2^{2n-1} \times (N+1)} - 1 \right\} \times 100$
Clock synchronous mode	$B = \frac{\phi \times 10^6}{8 \times 2^{2n-1} \times (N+1)}$	—
Smart card interface mode	$B = \frac{\phi \times 10^6}{S \times 2^{2n+1} \times (N+1)}$	$\text{Error (\%)} = \left\{ \frac{\phi \times 10^6}{B \times S \times 2^{2n+1} \times (N+1)} - 1 \right\} \times 100$

[Legend]

B: Bit rate (bit/s)

N: BRR setting for baud rate generator ($0 \leq N \leq 255$)

ϕ : Operating frequency (MHz)

n and S: Determined by the SMR settings shown in the following table.

SMR Setting			SMR Setting		
CKS1	CKS0	n	BCP1	BCP0	S
0	0	0	0	0	32
0	1	1	0	1	64
1	0	2	1	0	372
1	1	3	1	1	256

Table 14.3 shows sample N settings in BRR in normal asynchronous mode. Table 14.4 shows the maximum bit rate settable for each frequency. Table 14.6 and 14.8 show sample N settings in BRR in clock synchronous mode and smart card interface mode, respectively. In smart card interface mode, the number of basic clock cycles S in a 1-bit data transfer time can be selected. For details, see section 14.7.4, Receive Data Sampling Timing and Reception Margin. Tables 14.5 and 14.7 show the maximum bit rates with external clock input.

Table 14.3 Examples of BRR Settings for Various Bit Rates (Asynchronous Mode) (1)

Bit Rate (bit/s)	Operating Frequency ϕ (MHz)														
	5			6			6.144			7.3728			8		
	n	N	Error (%)	n	N	Error (%)	n	N	Error (%)	n	N	Error (%)	n	N	Error (%)
110	2	88	-0.25	2	106	-0.44	2	108	0.08	2	130	-0.07	2	141	0.03
150	2	64	0.16	2	77	0.16	2	79	0.00	2	95	0.00	2	103	0.16
300	1	129	0.16	1	155	0.16	1	159	0.00	1	191	0.00	1	207	0.16
600	1	64	0.16	1	77	0.16	1	79	0.00	1	95	0.00	1	103	0.16
1200	0	129	0.16	0	155	0.16	0	159	0.00	0	191	0.00	0	207	0.16
2400	0	64	0.16	0	77	0.16	0	79	0.00	0	95	0.00	0	103	0.16
4800	0	32	-1.36	0	38	0.16	0	39	0.00	0	47	0.00	0	51	0.16
9600	0	15	1.73	0	19	-2.34	0	19	0.00	0	23	0.00	0	25	0.16
19200	0	7	1.73	0	9	-2.34	0	9	0.00	0	11	0.00	0	12	0.16
31250	0	4	0.00	0	5	0.00	0	5	2.40	—	—	—	0	7	0.00
38400	0	3	1.73	0	4	-2.34	0	4	0.00	0	5	0.00	—	—	—

Bit Rate (bit/s)	Operating Frequency ϕ (MHz)											
	9.8304			10			12			12.288		
	n	N	Error (%)	n	N	Error (%)	n	N	Error (%)	n	N	Error (%)
110	2	174	-0.26	2	177	-0.25	2	212	0.03	2	217	0.08
150	2	127	0.00	2	129	0.16	2	155	0.16	2	159	0.00
300	1	255	0.00	2	64	0.16	2	77	0.16	2	79	0.00
600	1	127	0.00	1	129	0.16	1	155	0.16	1	159	0.00
1200	0	255	0.00	1	64	0.16	1	77	0.16	1	79	0.00
2400	0	127	0.00	0	129	0.16	0	155	0.16	0	159	0.00
4800	0	63	0.00	0	64	0.16	0	77	0.16	0	79	0.00
9600	0	31	0.00	0	32	-1.36	0	38	0.16	0	39	0.00
19200	0	15	0.00	0	15	1.73	0	19	-2.34	0	19	0.00
31250	0	9	-1.70	0	9	0.00	0	11	0.00	0	11	2.40
38400	0	7	0.00	0	7	1.73	0	9	-2.34	0	9	0.00

[Legend]

—: Can be set, but there will be a degree of error.

Note: * Make the settings so that the error does not exceed 1%.

Table 14.3 Examples of BRR Settings for Various Bit Rates (Asynchronous Mode) (2)

Bit Rate (bit/s)	Operating Frequency ϕ (MHz)											
	14			14.7456			16			17.2032		
	n	N	Error (%)	n	N	Error (%)	n	N	Error (%)	n	N	Error (%)
110	2	248	-0.17	3	64	0.70	3	70	0.03	3	75	0.48
150	2	181	0.16	2	191	0.00	2	207	0.16	2	223	0.00
300	2	90	0.16	2	95	0.00	2	103	0.16	2	111	0.00
600	1	181	0.16	1	191	0.00	1	207	0.16	1	223	0.00
1200	1	90	0.16	1	95	0.00	1	103	0.16	1	111	0.00
2400	0	181	0.16	0	191	0.00	0	207	0.16	0	223	0.00
4800	0	90	0.16	0	95	0.00	0	103	0.16	0	111	0.00
9600	0	45	-0.93	0	47	0.00	0	51	0.16	0	55	0.00
19200	0	22	-0.93	0	23	0.00	0	25	0.16	0	27	0.00
31250	0	13	0.00	0	14	-1.70	0	15	0.00	0	16	1.20
38400	—	—	—	0	11	0.00	0	12	0.16	0	16	0.00

Bit Rate (bit/s)	Operating Frequency ϕ (MHz)														
	18			19.6608			20			25			33		
	n	N	Error (%)	n	N	Error (%)	n	N	Error (%)	n	N	Error (%)	n	N	Error (%)
110	3	79	-0.12	3	86	0.31	3	88	-0.25	3	110	-0.02	3	145	0.33
150	2	233	0.16	2	255	0.00	3	64	0.16	3	80	-0.47	3	106	0.39
300	2	116	0.16	2	127	0.00	2	129	0.16	2	162	0.15	2	214	-0.07
600	1	233	0.16	1	255	0.00	2	64	0.16	2	80	-0.47	2	106	0.39
1200	1	116	0.16	1	127	0.00	1	129	0.16	1	162	0.15	1	214	-0.07
2400	0	233	0.16	0	255	0.00	1	64	0.16	1	80	-0.47	1	106	0.39
4800	0	116	0.16	0	127	0.00	0	129	0.16	0	162	0.15	0	214	-0.07
9600	0	58	-0.69	0	63	0.00	0	64	0.16	0	80	-0.47	0	106	0.39
19200	0	28	1.02	0	31	0.00	0	32	-1.36	0	40	-0.76	0	53	-0.54
31250	0	17	0.00	0	19	-1.70	0	19	0.00	0	24	0.00	0	32	0.00
38400	0	14	-2.34	0	15	0.00	0	15	1.73	0	19	1.73	0	26	-0.54

[Legend]

—: Can be set, but there will be a degree of error.

Note: * Make the settings so that the error does not exceed 1%.

Table 14.4 Maximum Bit Rate for Each Frequency (Asynchronous Mode)

ϕ (MHz)	Maximum Bit Rate (bit/s)	n	N	ϕ (MHz)	Maximum Bit Rate (bit/s)	n	N
5	156250	0	0	14	437500	0	0
6	187500	0	0	14.7456	460800	0	0
6.144	192000	0	0	16	500000	0	0
7.3728	230400	0	0	17.2032	537600	0	0
8	250000	0	0	18	562500	0	0
9.8304	307200	0	0	19.6608	614400	0	0
10	312500	0	0	20	625000	0	0
12	375000	0	0	25	781250	0	0
12.288	384000	0	0	33	1031250	0	0

Table 14.5 Maximum Bit Rate with External Clock Input (Asynchronous Mode)

ϕ (MHz)	External Input Clock (MHz)	Maximum Bit Rate (bit/s)	ϕ (MHz)	External Input Clock (MHz)	Maximum Bit Rate (bit/s)
5	1.2500	78125	14	3.5000	218750
6	15.000	93750	14.7456	3.6864	230400
6.144	1.5360	96000	16	4.0000	250000
7.3728	1.8432	115200	17.2032	4.3008	268800
8	2.0000	125000	18	4.5000	281250
9.8304	2.4576	153600	19.6608	4.9152	307200
10	2.5000	156250	20	5.0000	312500
12	3.0000	187500	25	6.2500	390625
12.288	3.0720	192000	33	8.2500	515625

Table 14.6 BRR Settings for Various Bit Rates (Clock Synchronous Mode)

Bit Rate (bit/s)	Operating Frequency ϕ (MHz)												
	8		10		16		20		24		32		
	n	N	n	N	n	N	n	N	n	N	n	N	
110	/												
250	3	124	—	—	3	249	/						
500	2	249	—	—	3	124	—	—	—	—	3	249	
1k	2	124	—	—	2	249	—	—	—	—	3	124	
2.5k	1	199	1	249	2	99	2	124	2	149	2	199	
5k	1	99	1	124	1	199	1	249	2	74	2	99	
10k	0	199	0	249	1	99	1	124	1	149	1	199	
25k	0	79	0	99	0	159	0	199	0	239	0	179	
50k	0	39	0	49	0	79	0	99	0	119	0	159	
100k	0	19	0	24	0	39	0	49	0	59	0	79	
250k	0	7	0	9	0	15	0	19	0	23	0	31	
500k	0	3	0	4	0	7	0	9	0	11	0	15	
1M	0	1	/		0	3	0	4	0	5	0	7	
2.5M	/		0	0*	/			0	1	/			
5M	/						0	0*	/				

[Legend]

- : Setting prohibited.
 —: Can be set, but there will be a degree of error.
 *: Continuous transfer or reception is not possible.

Table 14.7 Maximum Bit Rate with External Clock Input (Clock Synchronous Mode)

ϕ (MHz)	External Input Clock (MHz)	Maximum Bit Rate (bit/s)	ϕ (MHz)	External Input Clock (MHz)	Maximum Bit Rate (bit/s)
6	1.0000	1000000.0	16	2.6667	2666666.7
8	1.3333	1333333.3	18	3.0000	3000000.0
10	1.6667	1666666.7	20	3.3333	3333333.3
12	2.0000	2000000.0	25	4.1667	4166666.7
14	2.3333	2333333.3	33	5.5000	5500000.0

Table 14.8 BRR Settings for Various Bit Rates (Smart Card Interface Mode, n = 0, s = 372)

Bit Rate (bit/s)	Operating Frequency ϕ (MHz)															
	7.1424			10.00			13.00			14.2848			16.00			
	n	N	Error (%)	n	N	Error (%)	n	N	Error (%)	n	N	Error (%)	n	N	Error (%)	
9600	0	0	0.00	0	1	30	0	1	-8.99	0	1	0.00	0	1	12.01	

Bit Rate (bit/s)	Operating Frequency ϕ (MHz)															
	18.00			20.00			21.4272			25			33			
	n	N	Error (%)	n	N	Error (%)	n	N	Error (%)	n	N	Error (%)	n	N	Error (%)	
9600	0	2	-15.99	0	2	-6.65	0	2	0.00	0	3	-12.49	0	4	-7.59	

Table 14.9 Maximum Bit Rate for Each Frequency (Smart Card Interface Mode, S = 372)

ϕ (MHz)	Maximum Bit Rate			ϕ (MHz)	Maximum Bit Rate		
	(bit/s)	n	N		(bit/s)	n	N
7.1424	9600	0	0	18.00	24194	0	0
10.00	13441	0	0	20.00	26882	0	0
13.00	17473	0	0	21.4272	28800	0	0
14.2848	19200	0	0	25.00	33602	0	0
16.00	21505	0	0	33.00	44355	0	0

14.3.10 Serial Interface Control Register (SCICR)

SCICR controls IrDA operation of SCI_1.

Bit	Bit Name	Initial Value	R/W	Description	
7	IrE	0	R/W	IrDA Enable Specifies SCI_1 I/O pins for either normal SCI or IrDA. 0: TxD1/IrTxD and RxD1/IrRxD pins function as TxD1 and RxD1 pins, respectively 1: TxD1/IrTxD and RxD1/IrRxD pins function as IrTxD and IrRxD pins, respectively	
6	IrCKS2	0	R/W	IrDA Clock Select 2 to 0	
5	IrCKS1	0	R/W	These bits specify the high-level width of the clock pulse during IrTxD output pulse encoding when the IrDA function is enabled. 000: $B \times 3/16$ (three sixteenths of the bit rate) 001: $\phi/2$ 010: $\phi/4$ 011: $\phi/8$ 100: $\phi/16$ 101: $\phi/32$ 110: $\phi/64$ 111: $\phi/128$	
4	IrCKS0	0	R/W		
3, 2	—	All 0	R/W		Reserved The initial value should no be changed.
1, 0	—	All 0	R		Reserved These bits are always read as 0 and cannot be modified.

14.3.11 Serial Enhanced Mode Register_0 and 2 (SEMR_0 and SEMR_2)

SEMR_0 and SEMR_2 select the SCI_0 and SCI_2 functions, respectively, and the clock source in asynchronous mode. The basic clock is automatically specified when the average transfer rate operation is selected.

Bit	Bit Name	Initial Value	R/W	Description
7	SSE	0	R/W	<p>SCI Select Enable</p> <p>Enables/disables the external pins to select the SCI functions when the external clock is supplied in clock synchronous mode.</p> <p>0: Disables the external pins to select the SCI functions (normal)</p> <p>1: Enables the external pins to select the SCI functions</p> <ul style="list-style-type: none"> • SCI_0 <p>SSE0 pin input = 0 (selected state): SCI_0 operates normally</p> <p>SSE0 pin input = 1 (non-selected state): SCI_0 halts operation (TxD0 = high-impedance state, SCK0 = fixed to high)</p> <ul style="list-style-type: none"> • SCI_2 <p>SSE2 pin input = 0 (selected state): SCI_2 operates normally</p> <p>SSE2 pin input = 1 (non-selected state): SCI_2 halts operation (TxD2 = high-impedance state, SCK2 = fixed to high)</p>
6, 5	—	All 0	R	<p>Reserved</p> <p>These bits are always read as 0 and cannot be modified.</p>
3	ABCS	0	R/W	<p>Asynchronous Mode Basic Clock Select</p> <p>Specifies the basic clock for a 1-bit cycle in asynchronous mode.</p> <p>This bit is valid only in asynchronous mode (C/\bar{A} bit in SMR is 0).</p> <p>0: The basic clock has a frequency 16 times the transfer clock frequency (normal operation)</p> <p>1: The basic clock has a frequency 8 times the transfer clock frequency (double-speed operation)</p>

Bit	Bit Name	Initial Value	R/W	Description
4	ACS4	0	R/W	Asynchronous Mode Clock Source Select
2	ACS2	0	R/W	Specify the clock source and the average transfer rate in asynchronous mode. These bits are valid only when external clock is supplied in asynchronous mode.
1	ACS1	0	R/W	
0	ACS0	0	R/W	
				0000: Normal operation with external clock input and average transfer rate operation not used (operated using the basic clock with a frequency 16 or 8 times the transfer clock frequency)
				0001: Average transfer rate operation at 115.152 kbps when the system clock frequency is 10.667 MHz (operated using the basic clock with a frequency 16 times the transfer clock frequency)
				0010: Average transfer rate operation at 460.606 kbps when the system clock frequency is 10.667 MHz (operated using the basic clock with a frequency 8 times the transfer clock frequency)
				0011: Average transfer rate operation at 720 kbps when the system clock frequency is 32 MHz (operated using the basic clock with a frequency 16 times the transfer clock frequency)
				0100: Reserved
				0101: Average transfer rate operation at 115.196 kbps when the system clock frequency is 16 MHz (operated using the basic clock with a frequency 16 times the transfer clock frequency)
				0110: Average transfer rate operation at 460.784 kbps when the system clock frequency is 16 MHz (operated using the basic clock with a frequency 16 times the transfer clock frequency)
				0111: Average transfer rate operation at 720 kbps when the system clock frequency is 16 MHz (operated using the basic clock with a frequency 8 times the transfer clock frequency)
				1000: Average transfer rate operation at 115.196 kbps when the system clock frequency is 16 MHz (operated using the basic clock with a frequency 16 times the transfer clock frequency)
				1001: Average transfer rate operation at 230.392 kbps when the system clock frequency is 16 MHz (operated using the basic clock with a frequency 16 times the transfer clock frequency)

Bit	Bit Name	Initial Value	R/W	Description
4	ACS4	0	R/W	1010: Average transfer rate operation at 115.196 kbps
2	ACS2	0	R/W	when the system clock frequency is 20 MHz
1	ACS1	0	R/W	(operated using the basic clock with a frequency
0	ACS0	0	R/W	16 times the transfer clock frequency)
				1011: Average transfer rate operation at 230.392 kbps
				when the system clock frequency is 20 MHz
				(operated using the basic clock with a frequency
				16 times the transfer clock frequency)
				1100: Average transfer rate operation at 115.196 kbps
				when the system clock frequency is 24 MHz
				(operated using the basic clock with a frequency
				16 times the transfer clock frequency)
				1101: Average transfer rate operation at 230.392 kbps
				when the system clock frequency is 24 MHz
				(operated using the basic clock with a frequency
				16 times the transfer clock frequency)
				1110: Average transfer rate operation at 460.784 kbps
				when the system clock frequency is 24 MHz
				(operated using the basic clock with a frequency
				16 times the transfer clock frequency)
				1111: Average transfer rate operation at 720 kbps when
				the system clock frequency is 24 MHz (operated
				using the basic clock with a frequency 8 times the
				transfer clock frequency)

Table 14.10 Asynchronous Mode Clock Source Select

ACS 4	ACS 2	ACS 1	ACS 0	Average Transfer Rate	System Clock (ϕ)	Operating Clock
0	0	0	0	None	External clock input, normal operation	Transfer rate \times 16 or Transfer rate \times 8
0	0	0	1	115.152 kbps	10.667 MHz	Transfer rate \times 16
0	0	1	0	460.606 kbps	10.667 MHz	Transfer rate \times 8
0	0	1	1	Reserved	Reserved	Reserved
0	1	0	0	Reserved	Reserved	Reserved
0	1	0	1	115.196 kbps	16 MHz	Transfer rate \times 16
0	1	1	0	460.784 kbps	16 MHz	Transfer rate \times 16
0	1	1	1	720 kbps	16 MHz	Transfer rate \times 8
1	0	0	0	115.196 kbps	16 MHz	Transfer rate \times 16
1	0	0	1	230.392 kbps	16 MHz	Transfer rate \times 16
1	0	1	0	115.196 kbps	20 MHz	Transfer rate \times 16

ACS 4	ACS 2	ACS 1	ACS 0	Average Transfer Rate	System Clock (ϕ)	Operating Clock
1	0	1	1	230.392 kbps	20 MHz	Transfer rate \times 16
1	1	0	0	115.196 kbps	24 MHz	Transfer rate \times 16
1	1	0	1	230.392 kbps	24 MHz	Transfer rate \times 16
1	1	1	0	460.784 kbps	24 MHz	Transfer rate \times 16
1	1	1	1	720 kbps	24 MHz	Transfer rate \times 8

14.4 Operation in Asynchronous Mode

Figure 14.3 shows the general format for asynchronous serial communication. One frame consists of a start bit (low level), followed by transmit/receive data, a parity bit, and finally stop bits (high level). In asynchronous serial communication, the transmission line is usually held in the mark state (high level). The SCI monitors the transmission line, and when it goes to the space state (low level), recognizes a start bit and starts serial communication. Inside the SCI, the transmitter and receiver are independent units, enabling full-duplex communication. Both the transmitter and the receiver also have a double-buffered structure, so that data can be read or written during transmission or reception, enabling continuous data transfer and reception.

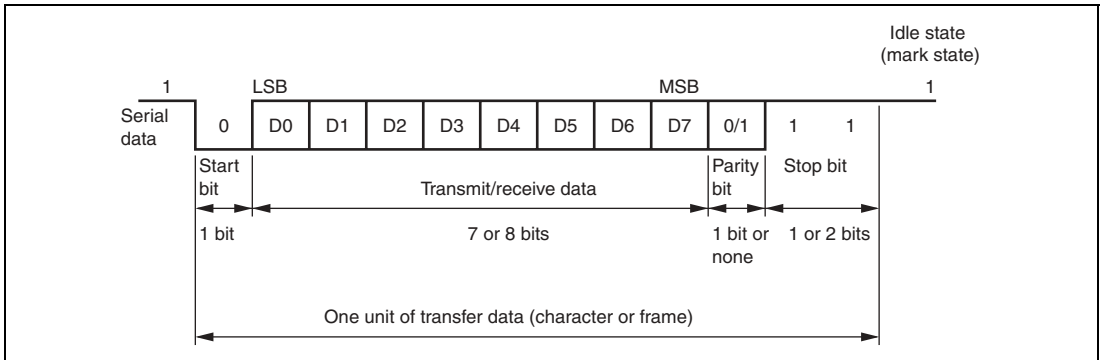

**Figure 14.3 Data Format in Asynchronous Communication
(Example with 8-Bit Data, Parity, Two Stop Bits)**

14.4.1 Data Transfer Format

Table 14.11 shows the data transfer formats that can be used in asynchronous mode. Any of 12 transfer formats can be selected according to the SMR setting. For details on the multiprocessor bit, see section 14.5, Multiprocessor Communication Function.

Table 14.11 Serial Transfer Formats (Asynchronous Mode)

SMR Settings				Serial Transmit/Receive Format and Frame Length													
CHR	PE	MP	STOP	1	2	3	4	5	6	7	8	9	10	11	12		
0	0	0	0	S	8-bit data								STOP				
0	0	0	1	S	8-bit data								STOP	STOP			
0	1	0	0	S	8-bit data								P	STOP			
0	1	0	1	S	8-bit data								P	STOP	STOP		
1	0	0	0	S	7-bit data							STOP					
1	0	0	1	S	7-bit data							STOP	STOP				
1	1	0	0	S	7-bit data							P	STOP				
1	1	0	1	S	7-bit data							P	STOP	STOP			
0	—	1	0	S	8-bit data								MPB	STOP			
0	—	1	1	S	8-bit data								MPB	STOP	STOP		
1	—	1	0	S	7-bit data							MPB	STOP				
1	—	1	1	S	7-bit data							MPB	STOP	STOP			

[Legend]

S: Start bit

STOP: Stop bit

P: Parity bit

MPB: Multiprocessor bit

14.4.2 Receive Data Sampling Timing and Reception Margin in Asynchronous Mode

In asynchronous mode, the SCI operates on a basic clock with a frequency of 16 times the bit rate. In reception, the SCI samples the falling edge of the start bit using the basic clock, and performs internal synchronization. Since receive data is latched internally at the rising edge of the 8th pulse of the basic clock, data is latched at the middle of each bit, as shown in figure 14.4. Thus the reception margin in asynchronous mode is determined by formula (1) below.

$$M = \left\{ \left(0.5 - \frac{1}{2N} \right) - \frac{D - 0.5}{N} (1 + F) - (L - 0.5) F \right\} \times 100 \quad [\%] \quad \cdots \text{Formula (1)}$$

- M: Reception margin (%)
- N: Ratio of bit rate to clock (N = 16)
- D: Clock duty (D = 0.5 to 1.0)
- L: Frame length (L = 9 to 12)
- F: Absolute value of clock rate deviation

Assuming values of F = 0 and D = 0.5 in formula (1), the reception margin is determined by the formula below.

$$M = \left\{ 0.5 - 1 / (2 \times 16) \right\} \times 100 \quad [\%] = 46.875 \%$$

However, this is only the computed value, and a margin of 20% to 30% should be allowed in system design.

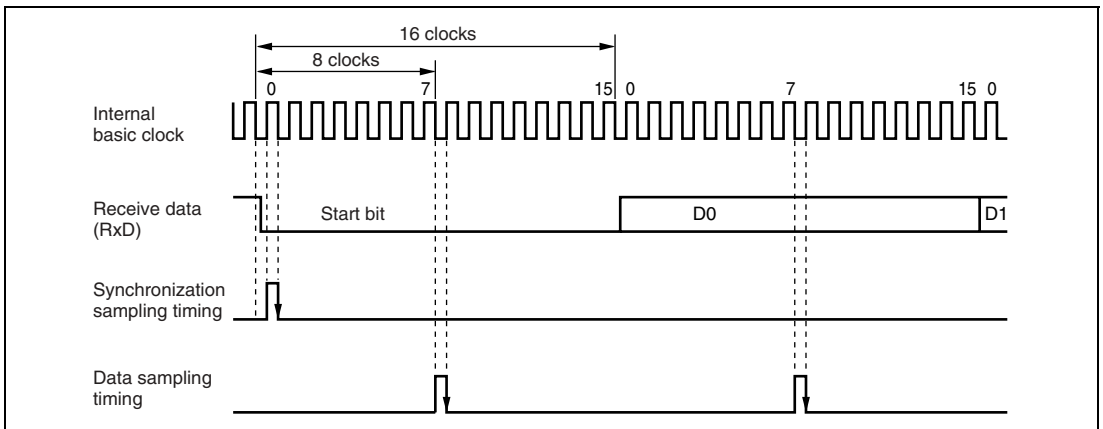

Figure 14.4 Receive Data Sampling Timing in Asynchronous Mode

14.4.3 Clock

Either an internal clock generated by the on-chip baud rate generator or an external clock input at the SCK pin can be selected as the SCI's transfer clock, according to the setting of the C/\bar{A} bit in SMR and the CKE1 and CKE0 bits in SCR. When an external clock is input at the SCK pin, the clock frequency should be 16 times the bit rate used.

When the SCI is operated on an internal clock, the clock can be output from the SCK pin. The frequency of the clock output in this case is equal to the bit rate, and the phase is such that the rising edge of the clock is in the middle of the transmit data, as shown in figure 14.5.

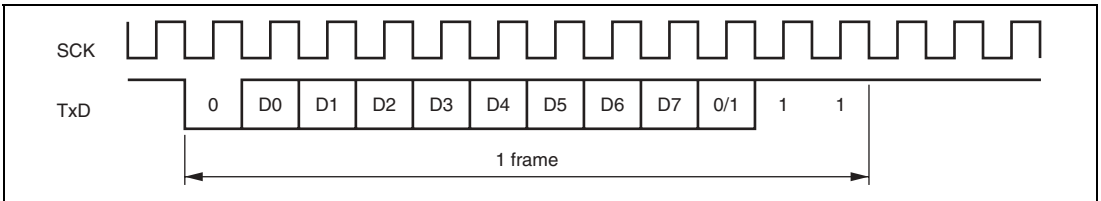

Figure 14.5 Relation between Output Clock and Transmit Data Phase (Asynchronous Mode)

14.4.4 Serial Enhanced Mode Clock

SCI_0 and SCI_2 can be operated not only based on the clocks described in section 14.4.3, Clock, but based on the following clocks, which are specified by the serial enhanced mode registers, SEMR_0 and SEMR_2.

Double-Speed Operation: Operations that are usually achieved using the clock with frequency 16 times the normal bit rate can be achieved using the clock with frequency 8 times the bit rate in this mode. That is, double transfer rate can be achieved using a single basic clock.

Double-speed operation can be specified by the ABCS bit in SEMR and is available for both clock sources of an internal clock generated by the on-chip baud rate generator and an external clock input at the SCK pin. However, double-speed operation cannot be specified when the average transfer rate operation is selected.

Average Transfer Rate Operation: The SCI can be operated based on the clock with an average transfer rate generated from the system clock instead of the external clock input at the SCK pin. In this case, the SCK pin is fixed to input.

Average transfer rate operation can be specified by the ACS4 and ACS2 to ACS0 bits in SEMR. Double-speed operation may be selected by clearing the ACS4 and ACS2 to ACS0 bits to 0.

Figures 14.6 and 14.7 show some examples of internal basic clock operations when average transfer rate operation is selected.

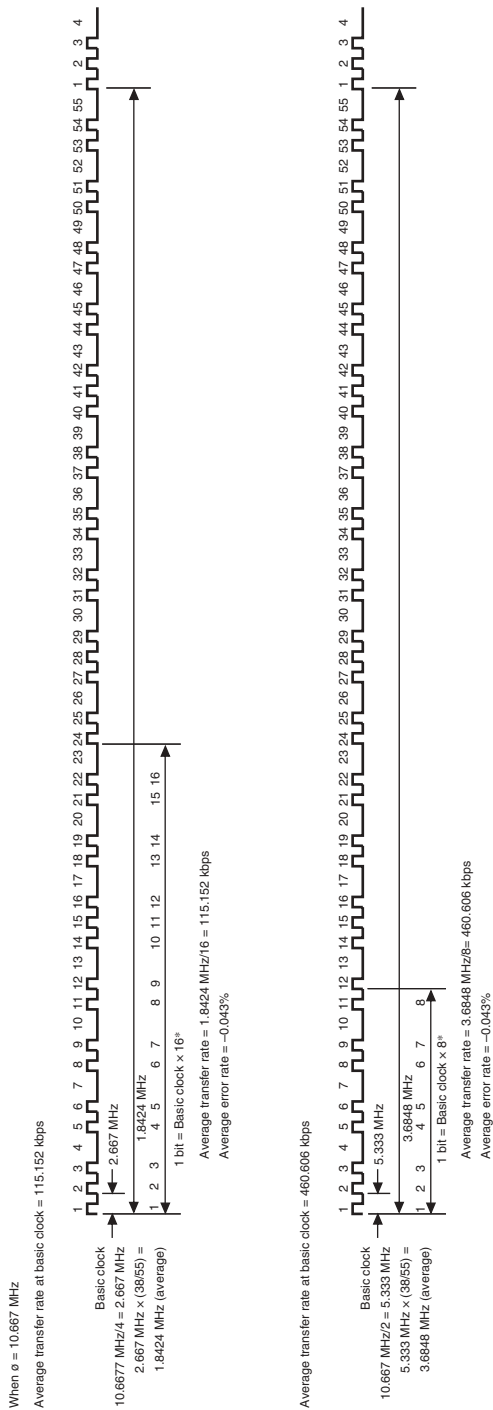

Note: * 1-bit length depends on the changes in basic clock synchronization.

Figure 14.6 Basic Clock Examples When Average Transfer Rate is Selected (1)

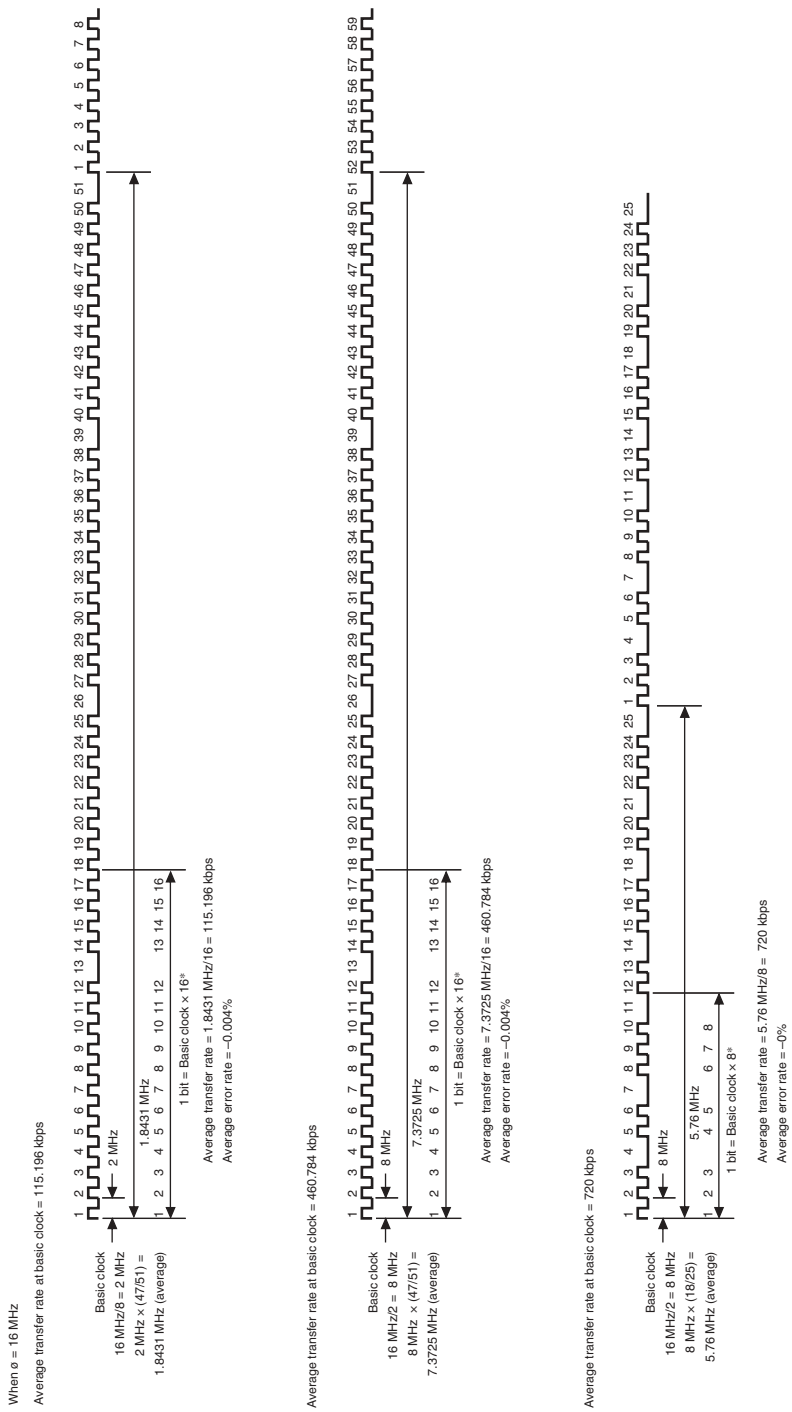

Note: * 1-bit length depends on the changes in basic clock synchronization.

Figure 14.7 Basic Clock Examples When Average Transfer Rate is Selected (2)

14.4.5 SCI Initialization (Asynchronous Mode)

Before transmitting and receiving data, you should first clear the TE and RE bits in SCR to 0, then initialize the SCI as shown in figure 14.8. When the operating mode, transfer format, etc., is changed, the TE and RE bits must be cleared to 0 before making the change using the following procedure. When the TE bit is cleared to 0, the TDRE flag in SSR is set to 1. Note that clearing the RE bit to 0 does not initialize the contents of the RDRF, PER, FER, and ORER flags in SSR, or the contents of RDR. When the external clock is used in asynchronous mode, the clock must be supplied even during initialization.

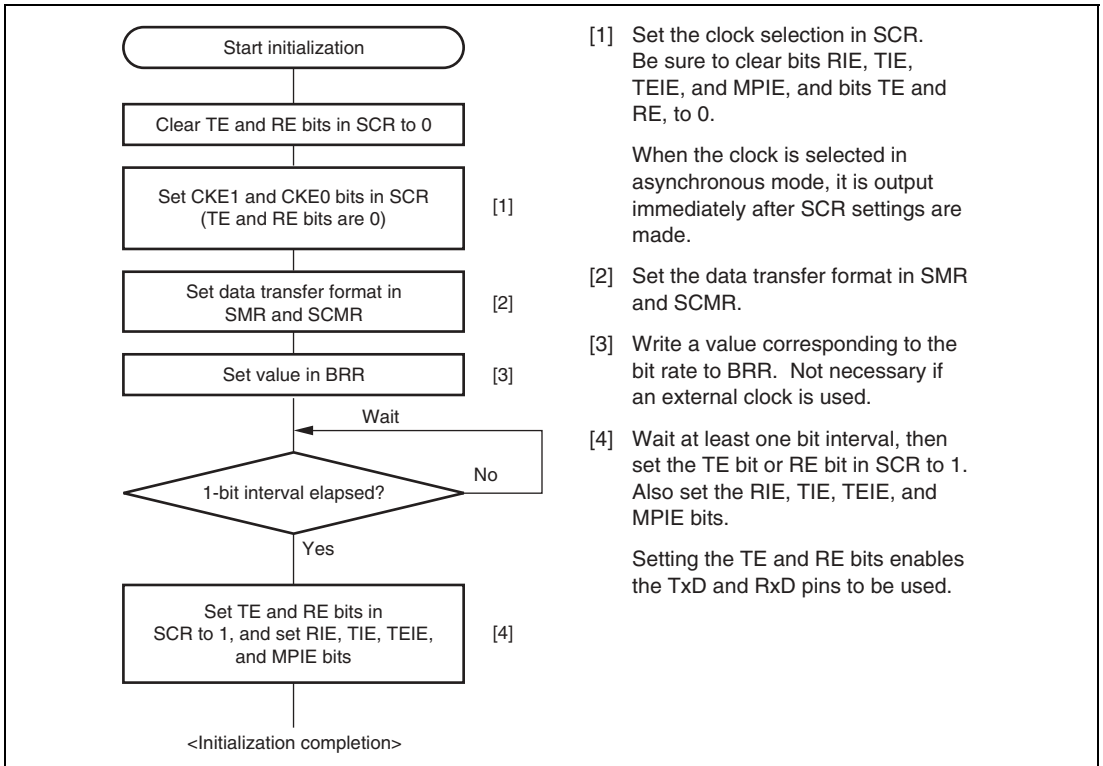

Figure 14.8 Sample SCI Initialization Flowchart

14.4.6 Serial Data Transmission (Asynchronous Mode)

Figure 14.9 shows an example of the operation for transmission in asynchronous mode. In transmission, the SCI operates as described below.

1. The SCI monitors the TDRE flag in SSR, and if it is cleared to 0, recognizes that data has been written to TDR, and transfers the data from TDR to TSR.
2. After transferring data from TDR to TSR, the SCI sets the TDRE flag to 1 and starts transmission. If the TIE bit in SCR is set to 1 at this time, a transmit data empty interrupt request (TXI) is generated. Because the TXI interrupt routine writes the next transmit data to TDR before transmission of the current transmit data has finished, continuous transmission can be enabled.
3. Data is sent from the TxD pin in the following order: start bit, transmit data, parity bit or multiprocessor bit (may be omitted depending on the format), and stop bit.
4. The SCI checks the TDRE flag at the timing for sending the stop bit.
5. If the TDRE flag is 0, the data is transferred from TDR to TSR, the stop bit is sent, and then serial transmission of the next frame is started.
6. If the TDRE flag is 1, the TEND flag in SSR is set to 1, the stop bit is sent, and then the “mark state” is entered in which 1 is output. If the TEIE bit in SCR is set to 1 at this time, a TEI interrupt request is generated.

Figure 14.10 shows a sample flowchart for transmission in asynchronous mode.

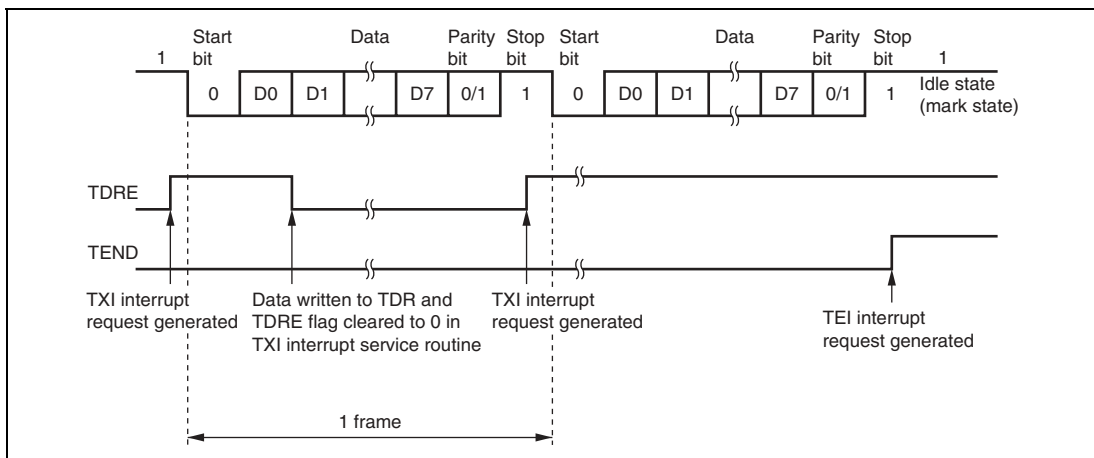
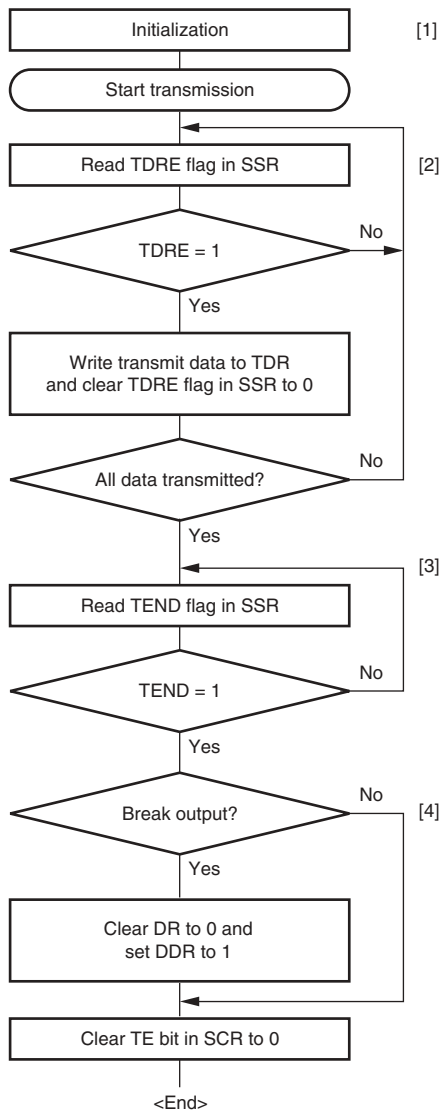

Figure 14.9 Example of Operation in Transmission in Asynchronous Mode (Example with 8-Bit Data, Parity, One Stop Bit)



- [1] SCI initialization:
The TxD pin is automatically designated as the transmit data output pin.
After the TE bit is set to 1, a frame of 1s is output, and transmission is enabled.
- [2] SCI status check and transmit data write:
Read SSR and check that the TDRE flag is set to 1, then write transmit data to TDR and clear the TDRE flag to 0.
- [3] Serial transmission continuation procedure:
To continue serial transmission, read 1 from the TDRE flag to confirm that writing is possible, then write data to TDR, and clear the TDRE flag to 0. However, the TDRE flag is checked and cleared automatically when the DTC is initiated by a transmit data empty interrupt (TXI) request and writes data to TDR.
- [4] Break output at the end of serial transmission:
To output a break in serial transmission, set DDR for the port corresponding to the TxD pin to 1, clear DR to 0, then clear the TE bit in SCR to 0.

Figure 14.10 Sample Serial Transmission Flowchart

14.4.7 Serial Data Reception (Asynchronous Mode)

Figure 14.11 shows an example of the operation for reception in asynchronous mode. In serial reception, the SCI operates as described below.

1. The SCI monitors the communication line, and if a start bit is detected, performs internal synchronization, receives receive data in RSR, and checks the parity bit and stop bit.
2. If an overrun error (when reception of the next data is completed while the RDRF flag in SSR is still set to 1) occurs, the ORER bit in SSR is set to 1. If the RIE bit in SCR is set to 1 at this time, an ERI interrupt request is generated. Receive data is not transferred to RDR. The RDRF flag remains to be set to 1.
3. If a parity error is detected, the PER bit in SSR is set to 1 and receive data is transferred to RDR. If the RIE bit in SCR is set to 1 at this time, an ERI interrupt request is generated.
4. If a framing error (when the stop bit is 0) is detected, the FER bit in SSR is set to 1 and receive data is transferred to RDR. If the RIE bit in SCR is set to 1 at this time, an ERI interrupt request is generated.
5. If reception finishes successfully, the RDRF bit in SSR is set to 1, and receive data is transferred to RDR. If the RIE bit in SCR is set to 1 at this time, an RXI interrupt request is generated. Because the RXI interrupt routine reads the receive data transferred to RDR before reception of the next receive data has finished, continuous reception can be enabled.

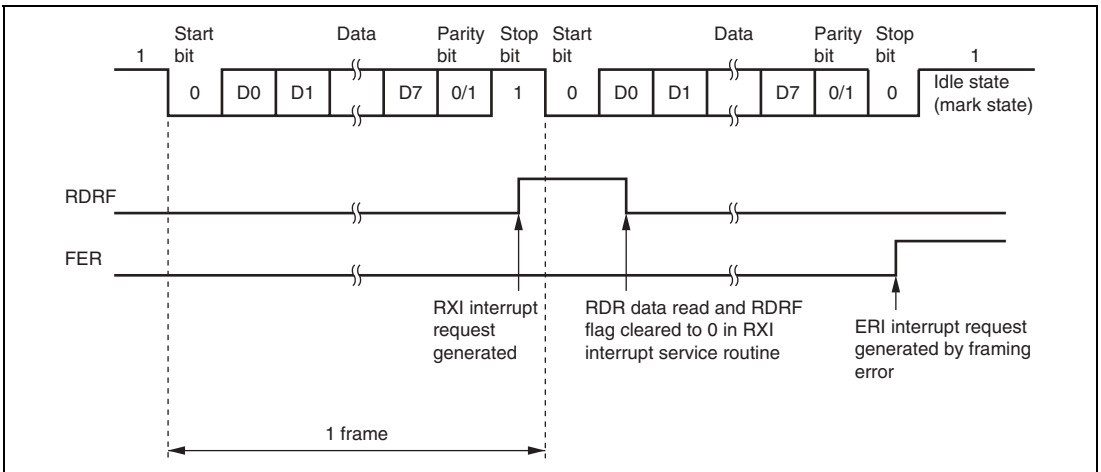

Figure 14.11 Example of SCI Operation in Reception (Example with 8-Bit Data, Parity, One Stop Bit)

Table 14.12 shows the states of the SSR status flags and receive data handling when a receive error is detected. If a receive error is detected, the RDRF flag retains its state before receiving data. Reception cannot be resumed while a receive error flag is set to 1. Accordingly, clear the ORER, FER, PER, and RDRF bits to 0 before resuming reception. Figure 14.12 shows a sample flowchart for serial data reception.

Table 14.12 SSR Status Flags and Receive Data Handling

SSR Status Flag				Receive Data	Receive Error Type
RDRF*	ORER	FER	PER		
1	1	0	0	Lost	Overflow error
0	0	1	0	Transferred to RDR	Framing error
0	0	0	1	Transferred to RDR	Parity error
1	1	1	0	Lost	Overflow error + framing error
1	1	0	1	Lost	Overflow error + parity error
0	0	1	1	Transferred to RDR	Framing error + parity error
1	1	1	1	Lost	Overflow error + framing error + parity error

Note: * The RDRF flag retains the state it had before data reception.

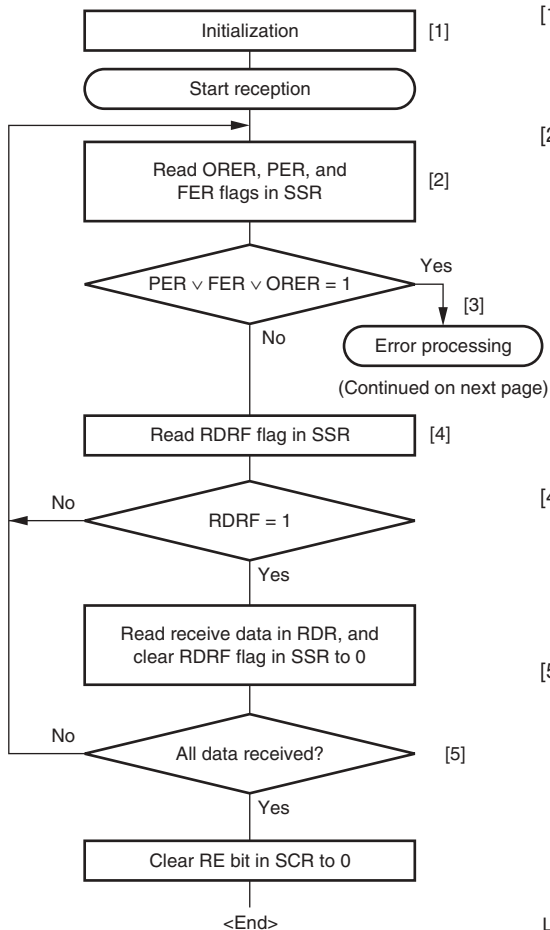

[1] SCI initialization:

The RxD pin is automatically designated as the receive data input pin.

[2] [3] Receive error processing and break detection:

If a receive error occurs, read the ORER, PER, and FER flags in SSR to identify the error. After performing the appropriate error processing, ensure that the ORER, PER, and FER flags are all cleared to 0. Reception cannot be resumed if any of these flags are set to 1. In the case of a framing error, a break can be detected by reading the value of the input port corresponding to the RxD pin.

[4] SCI status check and receive data read: Read SSR and check that RDRF = 1, then read the receive data in RDR and clear the RDRF flag to 0. Transition of the RDRF flag from 0 to 1 can also be identified by an RXI interrupt.

[5] Serial reception continuation procedure: To continue serial reception, before the stop bit for the current frame is received, read the RDRF flag, read RDR, and clear the RDRF flag to 0. However, the RDRF flag is cleared automatically when the DTC is initiated by an RXI interrupt and reads data from RDR.

Legend
 ∨ : Logical add (OR)

Figure 14.12 Sample Serial Reception Flowchart (1)

[3]

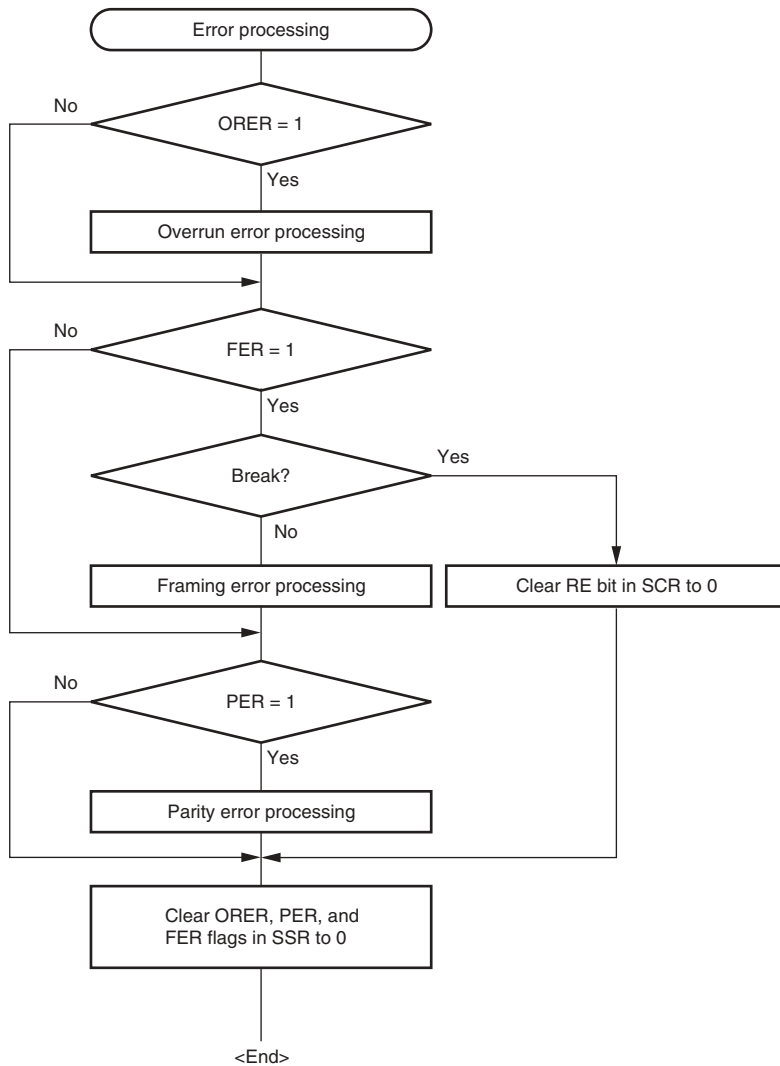

Figure 14.12 Sample Serial Reception Flowchart (2)

14.5 Multiprocessor Communication Function

Use of the multiprocessor communication function enables data transfer to be performed among a number of processors sharing communication lines by means of asynchronous serial communication using the multiprocessor format, in which a multiprocessor bit is added to the transfer data. When multiprocessor communication is carried out, each receiving station is addressed by a unique ID code. The serial communication cycle consists of two component cycles: an ID transmission cycle which specifies the receiving station, and a data transmission cycle for the specified receiving station. The multiprocessor bit is used to differentiate between the ID transmission cycle and the data transmission cycle. If the multiprocessor bit is 1, the cycle is an ID transmission cycle, and if the multiprocessor bit is 0, the cycle is a data transmission cycle. Figure 14.13 shows an example of inter-processor communication using the multiprocessor format. The transmitting station first sends the ID code of the receiving station with which it wants to perform serial communication as data with a 1 multiprocessor bit added. It then sends transmit data as data with a 0 multiprocessor bit added. When data with a 1 multiprocessor bit is received, the receiving station compares that data with its own ID. The station whose ID matches then receives the data sent next. Stations whose ID does not match continue to skip data until data with a 1 multiprocessor bit is again received.

The SCI uses the MPIE bit in SCR to implement this function. When the MPIE bit is set to 1, transfer of receive data from RSR to RDR, error flag detection, and setting the RDRF, FER, and ORER status flags in SSR to 1 are prohibited until data with a 1 multiprocessor bit is received. On reception of a receive character with a 1 multiprocessor bit, the MPB bit in SSR is set to 1 and the MPIE bit is automatically cleared, thus normal reception is resumed. If the RIE bit in SCR is set to 1 at this time, an RXI interrupt is generated.

When the multiprocessor format is selected, the parity bit setting is invalid. All other bit settings are the same as those in normal asynchronous mode. The clock used for multiprocessor communication is the same as that in normal asynchronous mode.

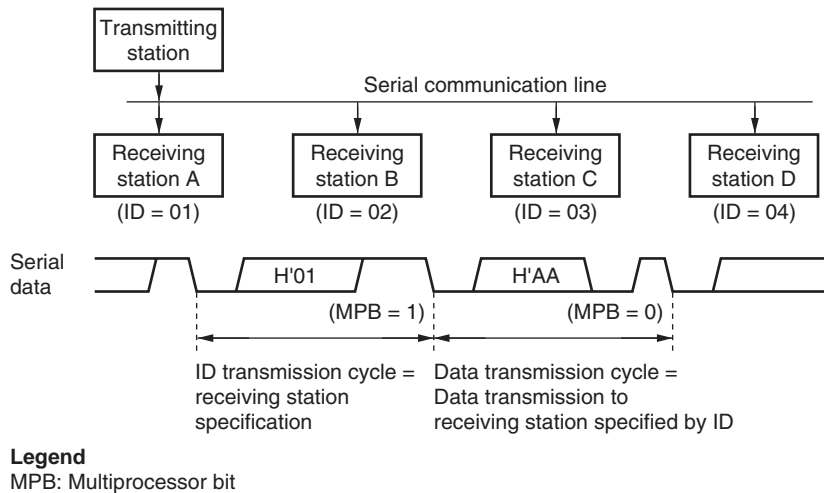

Figure 14.13 Example of Communication Using Multiprocessor Format (Transmission of Data H'AA to Receiving Station A)

14.5.1 Multiprocessor Serial Data Transmission

Figure 14.14 shows a sample flowchart for multiprocessor serial data transmission. For an ID transmission cycle, set the MPBT bit in SSR to 1 before transmission. For a data transmission cycle, clear the MPBT bit in SSR to 0 before transmission. All other SCI operations are the same as those in asynchronous mode.

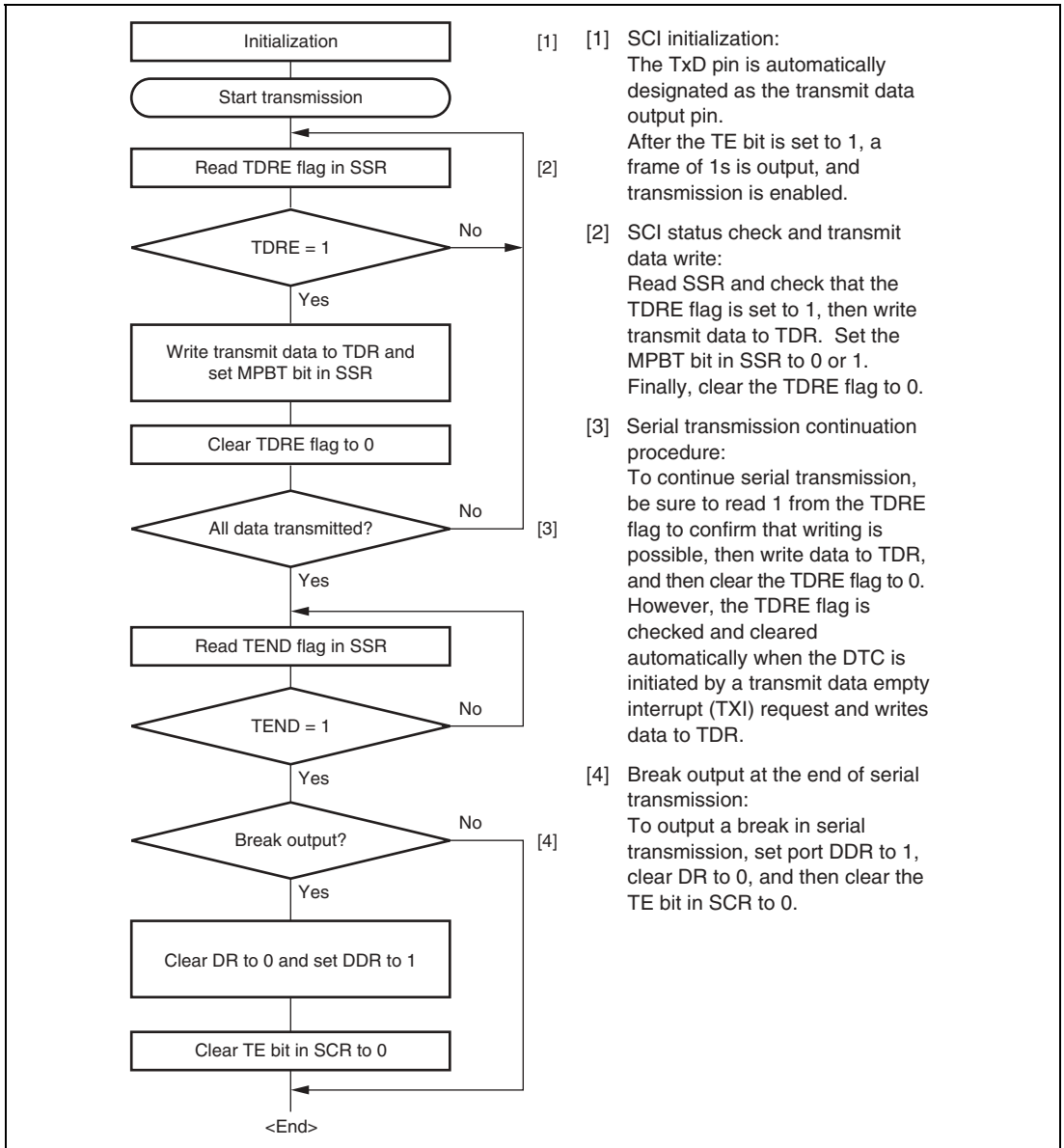

Figure 14.14 Sample Multiprocessor Serial Transmission Flowchart

14.5.2 Multiprocessor Serial Data Reception

Figure 14.16 shows a sample flowchart for multiprocessor serial data reception. If the MPIE bit in SCR is set to 1, data is skipped until data with a 1 multiprocessor bit is sent. On receiving data with a 1 multiprocessor bit, the receive data is transferred to RDR. An RXI interrupt request is generated at this time. All other SCI operations are the same as in asynchronous mode. Figure 14.15 shows an example of SCI operation for multiprocessor format reception.

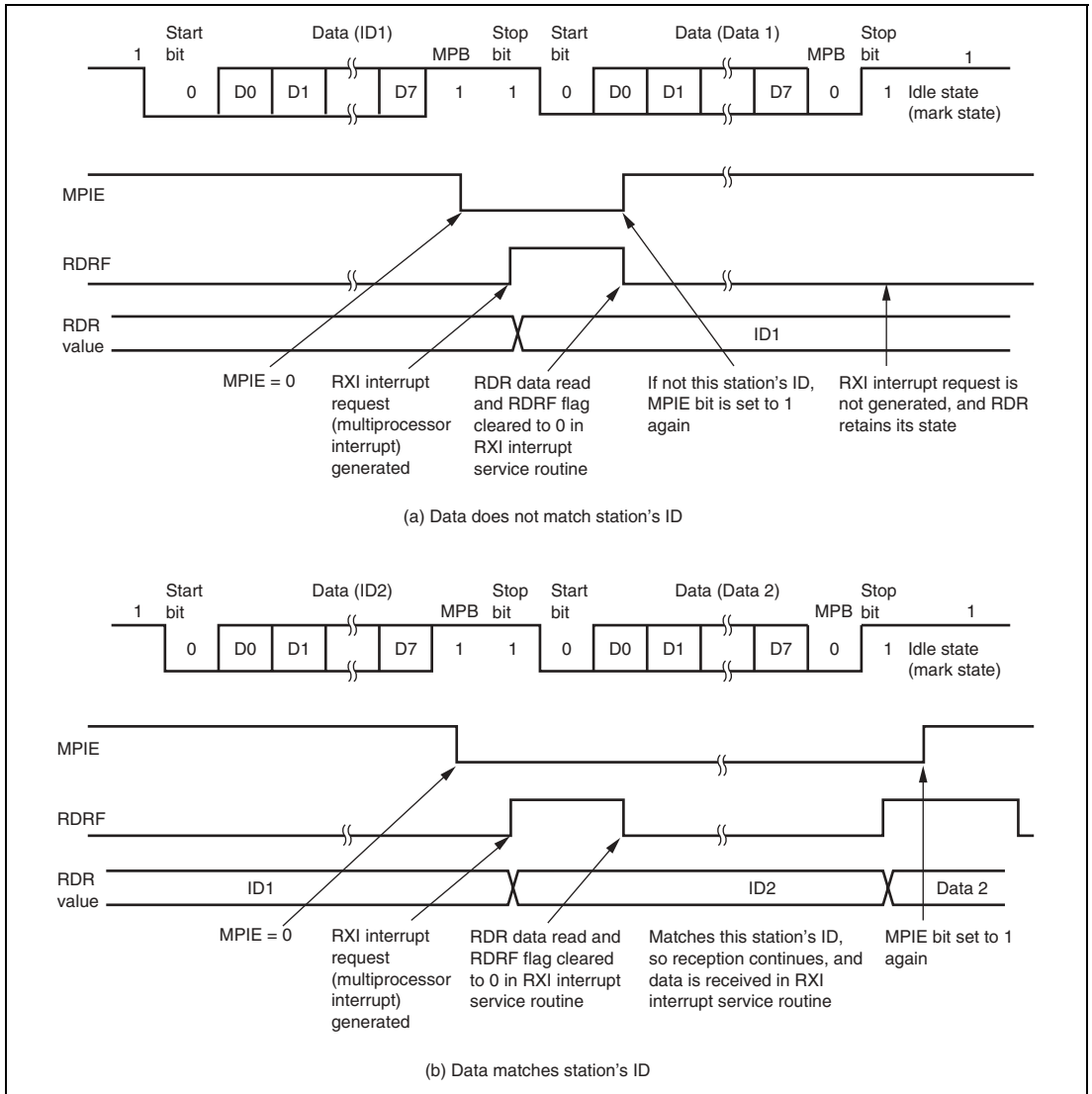
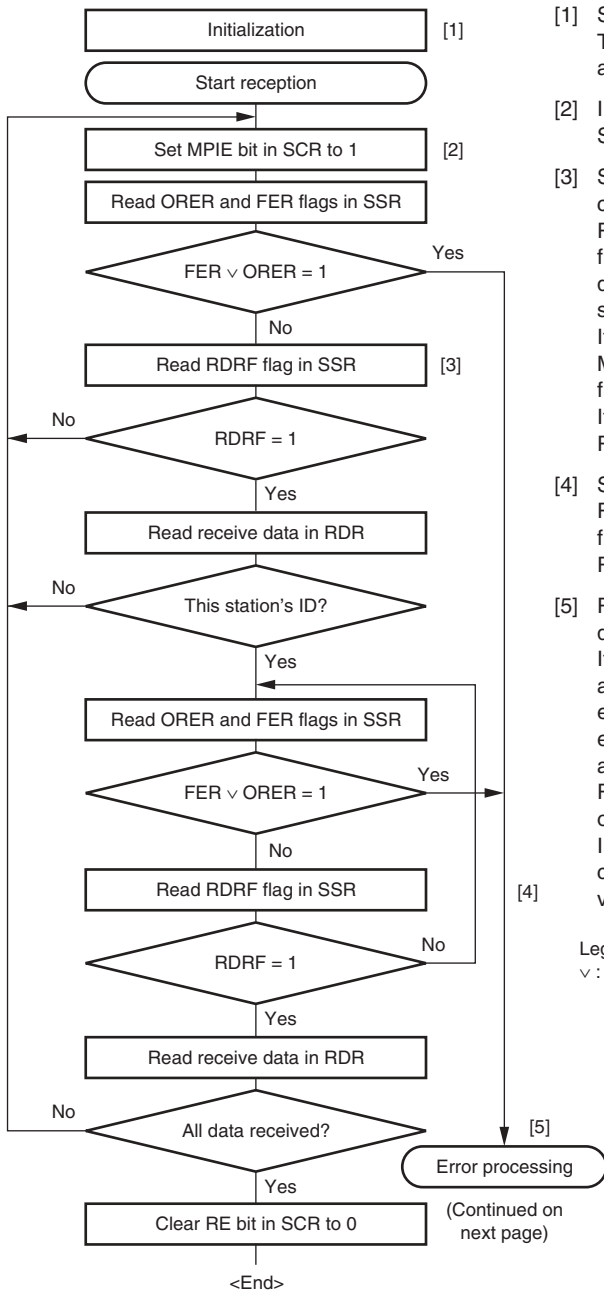

Figure 14.15 Example of SCI Operation in Reception (Example with 8-Bit Data, Multiprocessor Bit, One Stop Bit)



- [1] SCI initialization:
The RxD pin is automatically designated as the receive data input pin.
- [2] ID reception cycle:
Set the MPIE bit in SCR to 1.
- [3] SCI status check, ID reception and comparison:
Read SSR and check that the RDRF flag is set to 1, then read the receive data in RDR and compare it with this station's ID.
If the data is not this station's ID, set the MPIE bit to 1 again, and clear the RDRF flag to 0.
If the data is this station's ID, clear the RDRF flag to 0.
- [4] SCI status check and data reception:
Read SSR and check that the RDRF flag is set to 1, then read the data in RDR.
- [5] Receive error processing and break detection:
If a receive error occurs, read the ORER and FER flags in SSR to identify the error. After performing the appropriate error processing, ensure that the ORER and FER flags are all cleared to 0. Reception cannot be resumed if either of these flags is set to 1.
In the case of a framing error, a break can be detected by reading the RxD pin value.

Legend
 ∨ : Logical add (OR)

(Continued on next page)

Figure 14.16 Sample Multiprocessor Serial Reception Flowchart (1)

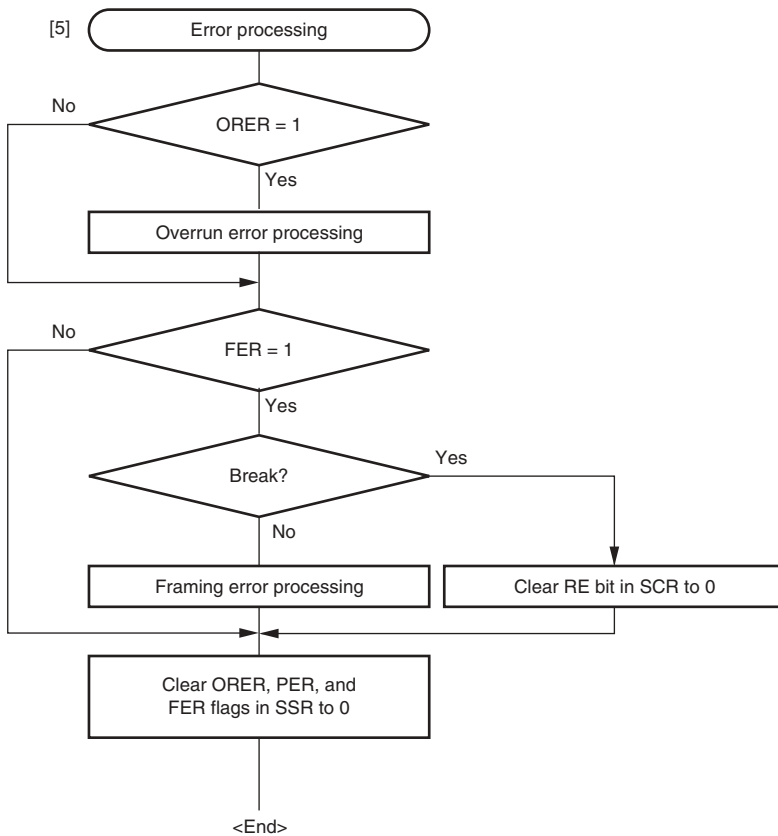

Figure 14.16 Sample Multiprocessor Serial Reception Flowchart (2)

14.6 Operation in Clock Synchronous Mode

Figure 14.17 shows the general format for clock synchronous communication. In clock synchronous mode, data is transmitted or received in synchronization with clock pulses. One character in transfer data consists of 8-bit data. In data transmission, the SCI outputs data from one falling edge of the synchronization clock to the next. In data reception, the SCI receives data in synchronization with the rising edge of the synchronization clock. After 8-bit data is output, the transmission line holds the MSB state. In clock synchronous mode, no parity or multiprocessor bit is added. Inside the SCI, the transmitter and receiver are independent units, enabling full-duplex communication by use of a common clock. Both the transmitter and the receiver also have a double-buffered structure, so that the next transmit data can be written during transmission or the previous receive data can be read during reception, enabling continuous data transfer.

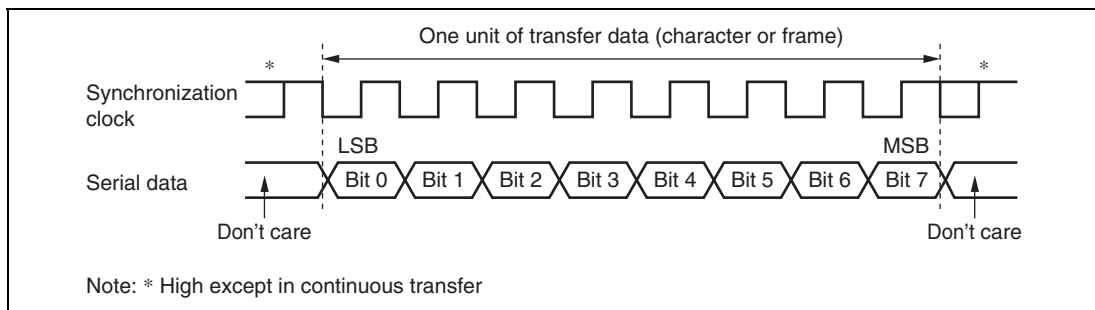

Figure 14.17 Data Format in Synchronous Communication (LSB-First)

14.6.1 Clock

Either an internal clock generated by the on-chip baud rate generator or an external synchronization clock input at the SCK pin can be selected, according to the setting of the CKE1 and CKE0 bits in SCR. When the SCI is operated on an internal clock, the synchronization clock is output from the SCK pin. Eight synchronization clock pulses are output in the transfer of one character, and when no transfer is performed the clock is fixed high.

14.6.2 SCI Initialization (Clock Synchronous Mode)

Before transmitting and receiving data, you should first clear the TE and RE bits in SCR to 0, then initialize the SCI as described in a sample flowchart in figure 14.18. When the operating mode, transfer format, etc., is changed, the TE and RE bits must be cleared to 0 before making the change using the following procedure. When the TE bit is cleared to 0, the TDRE flag in SSR is set to 1. However, clearing the RE bit to 0 does not initialize the RDRF, PER, FER, and ORER flags in SSR, or RDR.

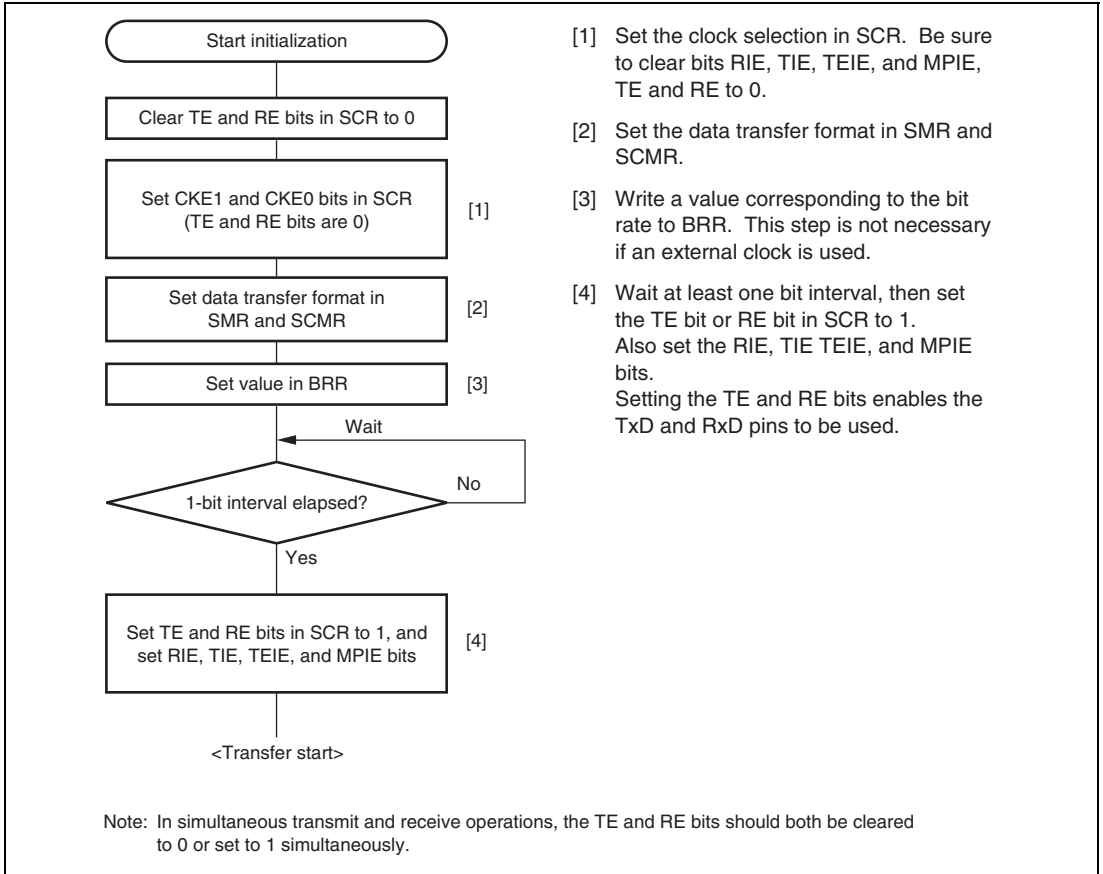

Figure 14.18 Sample SCI Initialization Flowchart

14.6.3 Serial Data Transmission (Clock Synchronous Mode)

Figure 14.19 shows an example of SCI operation for transmission in clock synchronous mode. In serial transmission, the SCI operates as described below.

1. The SCI monitors the TDRE flag in SSR, and if it is 0, recognizes that data has been written to TDR, and transfers the data from TDR to TSR.
2. After transferring data from TDR to TSR, the SCI sets the TDRE flag to 1 and starts transmission. If the TIE bit in SCR is set to 1 at this time, a TXI interrupt request is generated. Because the TXI interrupt routine writes the next transmit data to TDR before transmission of the current transmit data has finished, continuous transmission can be enabled.
3. 8-bit data is sent from the TxD pin synchronized with the output clock when output clock mode has been specified and synchronized with the input clock when use of an external clock has been specified.
4. The SCI checks the TDRE flag at the timing for sending the last bit.
5. If the TDRE flag is cleared to 0, data is transferred from TDR to TSR, and serial transmission of the next frame is started.
6. If the TDRE flag is set to 1, the TEND flag in SSR is set to 1, and the TxD pin maintains the output state of the last bit. If the TEIE bit in SCR is set to 1 at this time, a TEI interrupt request is generated. The SCK pin is fixed high.

Figure 14.20 shows a sample flowchart for serial data transmission. Even if the TDRE flag is cleared to 0, transmission will not start while a receive error flag (ORER, FER, or PER) is set to 1. Make sure to clear the receive error flags to 0 before starting transmission. Note that clearing the RE bit to 0 does not clear the receive error flags.

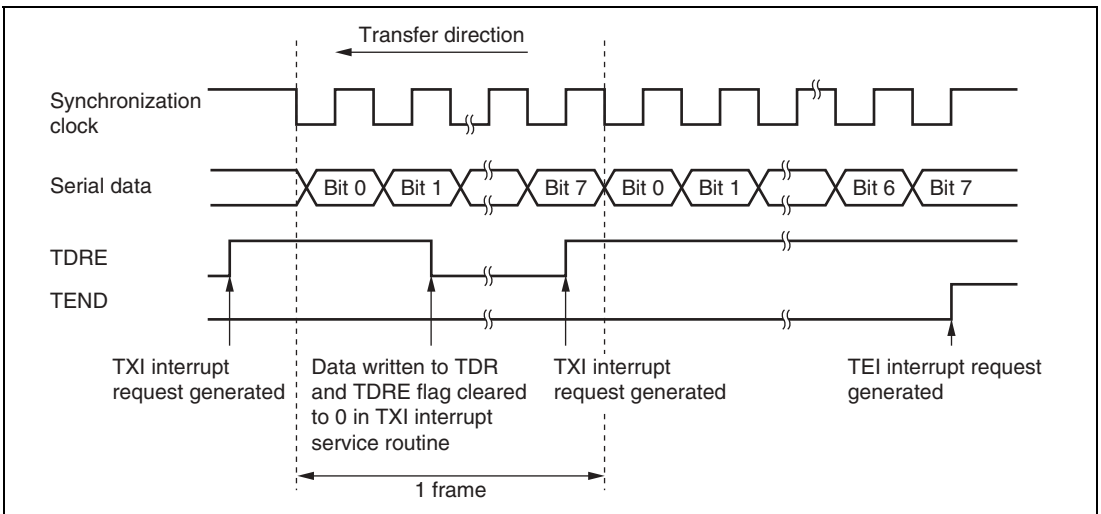
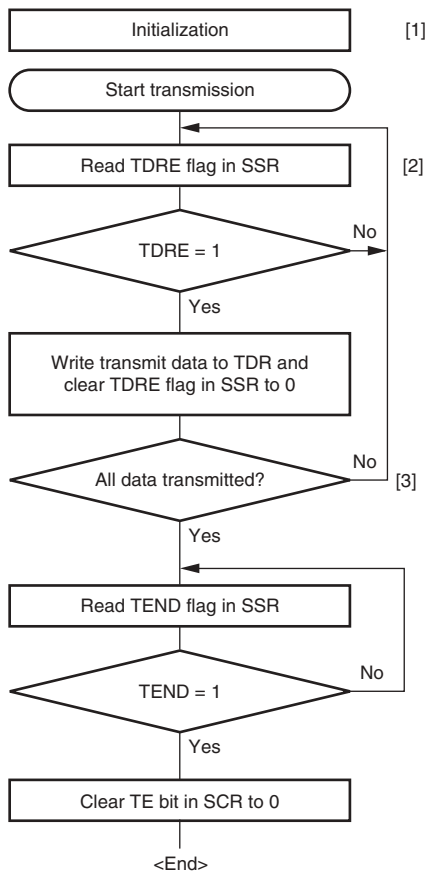

Figure 14.19 Sample SCI Transmission Operation in Clock Synchronous Mode



- [1] SCI initialization:
The TxD pin is automatically designated as the transmit data output pin.
- [2] SCI status check and transmit data write:
Read SSR and check that the TDRE flag is set to 1, then write transmit data to TDR and clear the TDRE flag to 0.
- [3] Serial transmission continuation procedure:
To continue serial transmission, be sure to read 1 from the TDRE flag to confirm that writing is possible, then write data to TDR, and then clear the TDRE flag to 0.
However, the TDRE flag is checked and cleared automatically when the DTC is initiated by a transmit data empty interrupt (TXI) request and writes data to TDR.

Figure 14.20 Sample Serial Transmission Flowchart

14.6.4 Serial Data Reception (Clock Synchronous Mode)

Figure 14.21 shows an example of SCI operation for reception in clock synchronous mode. In serial reception, the SCI operates as described below.

1. The SCI performs internal initialization in synchronization with a synchronization clock input or output, starts receiving data, and stores the receive data in RSR.
2. If an overrun error (when reception of the next data is completed while the RDRF flag is still set to 1) occurs, the ORER bit in SSR is set to 1. If the RIE bit in SCR is set to 1 at this time, an ERI interrupt request is generated. Receive data is not transferred to RDR. The RDRF flag remains to be set to 1.
3. If reception finishes successfully, the RDRF bit in SSR is set to 1, and receive data is transferred to RDR. If the RIE bit in SCR is set to 1 at this time, an RXI interrupt request is generated. Because the RXI interrupt routine reads the receive data transferred to RDR before reception of the next receive data has finished, continuous reception can be enabled.

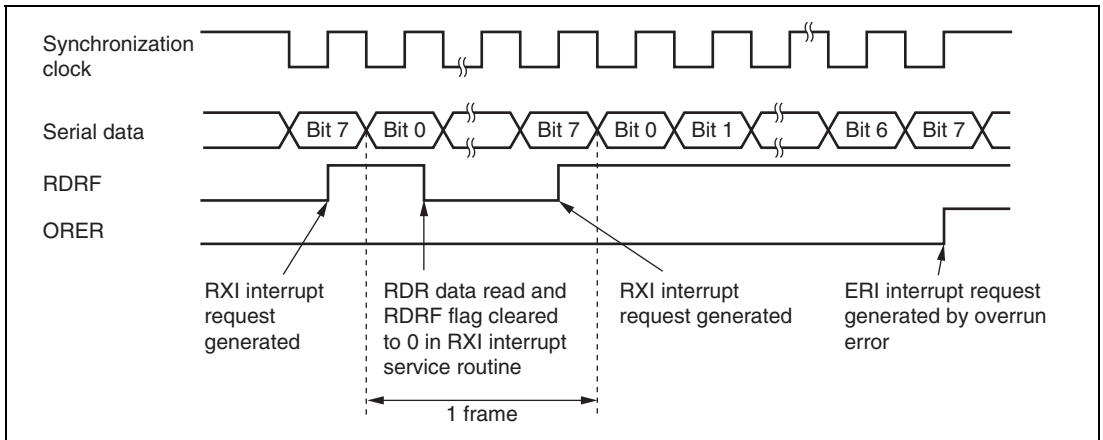
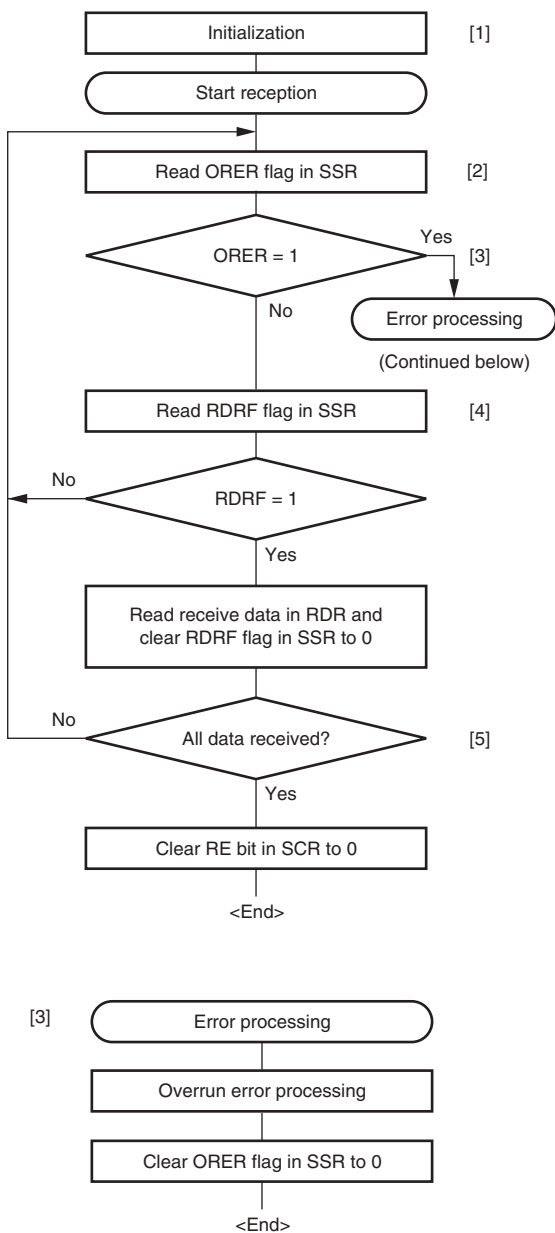

Figure 14.21 Example of SCI Receive Operation in Clock Synchronous Mode

Reception cannot be resumed while a receive error flag is set to 1. Accordingly, clear the ORER, FER, PER, and RDRF bits to 0 before resuming reception. Figure 14.22 shows a sample flowchart for serial data reception.



- [1] SCI initialization:
The Rx/D pin is automatically designated as the receive data input pin.
- [2] [3] Receive error processing:
If a receive error occurs, read the ORER flag in SSR, and after performing the appropriate error processing, clear the ORER flag to 0. Transfer cannot be resumed if the ORER flag is set to 1.
- [4] SCI status check and receive data read:
Read SSR and check that the RDRF flag is set to 1, then read the receive data in RDR and clear the RDRF flag to 0.
Transition of the RDRF flag from 0 to 1 can also be identified by an RXI interrupt.
- [5] Serial reception continuation procedure:
To continue serial reception, before the MSB (bit 7) of the current frame is received, reading the RDRF flag, reading RDR, and clearing the RDRF flag to 0 should be finished. However, the RDRF flag is cleared automatically when the DTC is initiated by a receive data full interrupt (RXI) and reads data from RDR.

Figure 14.22 Sample Serial Reception Flowchart

14.6.5 Simultaneous Serial Data Transmission and Reception (Clock Synchronous Mode)

Figure 14.23 shows a sample flowchart for simultaneous serial transmit and receive operations. After initializing the SCI, the following procedure should be used for simultaneous serial data transmit and receive operations. To switch from transmit mode to simultaneous transmit and receive mode, after checking that the SCI has finished transmission and the TDRE and TEND flags in SSR are set to 1, clear the TE bit in SCR to 0. Then simultaneously set the TE and RE bits to 1 with a single instruction. To switch from receive mode to simultaneous transmit and receive mode, after checking that the SCI has finished reception, clear the RE bit to 0. Then after checking that the RDRF bit in SSR and receive error flags (ORER, FER, and PER) are cleared to 0, simultaneously set the TE and RE bits to 1 with a single instruction.

14.6.6 SCI Selection in Serial Enhanced Mode

SCI_0 and SCI_2 provide the following capability according to the serial enhanced mode registers (SEMR_0 and SEMR_2) settings.

If the SCI is used in clock synchronous mode with clock input, the SCI channel can be enabled/disabled using the input at the external pins. The external pins include PA0/SSE0I (SCI_0) and PA1/SSE2I (SCI_2); therefore, this capability is not available in modes where the PA0 and PA1 pins are automatically set for address output.

When the SCI operation is disabled (not selected) by input at the external pins, TxD output is fixed to the high-impedance state and SCK input is internally fixed to high. One-to-multipoint communication is possible if the master device, which outputs SCK, controls these external pins for chip selection. SCI selection capability is selected using the SSE bits in SEMR.

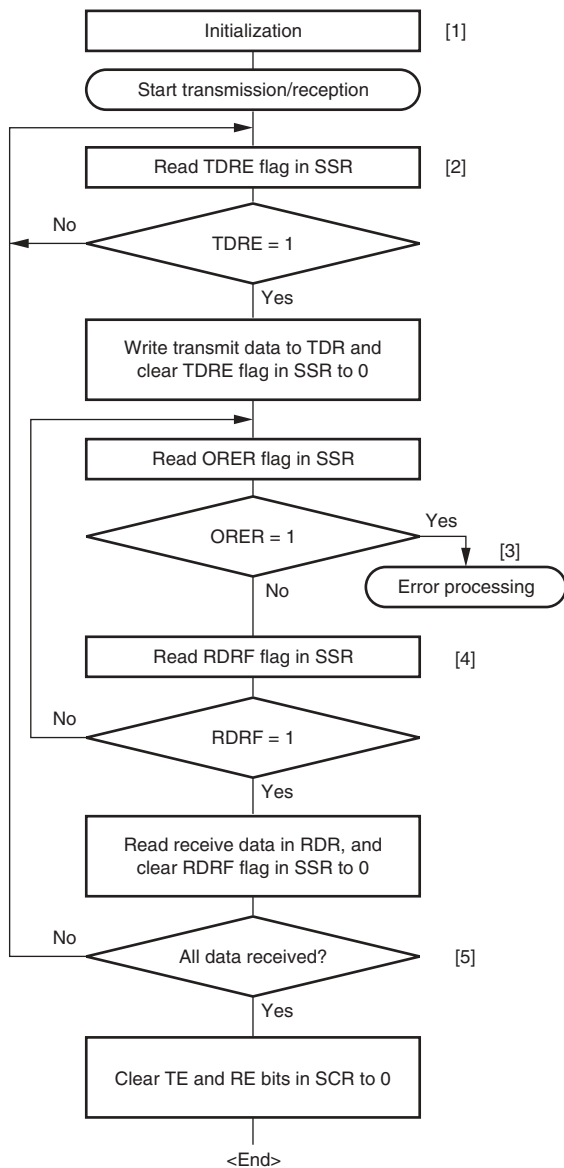

- [1] SCI initialization:
The TxD pin is designated as the transmit data output pin, and the RxD pin is designated as the receive data input pin, enabling simultaneous transmit and receive operations.
- [2] SCI status check and transmit data write:
Read SSR and check that the TDRE flag is set to 1, then write transmit data to TDR and clear the TDRE flag to 0.
Transition of the TDRE flag from 0 to 1 can also be identified by a TXI interrupt.
- [3] Receive error processing:
If a receive error occurs, read the ORER flag in SSR, and after performing the appropriate error processing, clear the ORER flag to 0. Transmission/reception cannot be resumed if the ORER flag is set to 1.
- [4] SCI status check and receive data read:
Read SSR and check that the RDRF flag is set to 1, then read the receive data in RDR and clear the RDRF flag to 0. Transition of the RDRF flag from 0 to 1 can also be identified by an RXI interrupt.
- [5] Serial transmission/reception continuation procedure:
To continue serial transmission/reception, before the MSB (bit 7) of the current frame is received, finish reading the RDRF flag, reading RDR, and clearing the RDRF flag to 0. Also, before the MSB (bit 7) of the current frame is transmitted, read 1 from the TDRE flag to confirm that writing is possible. Then write data to TDR and clear the TDRE flag to 0. However, the TDRE flag is checked and cleared automatically when the DTC is initiated by a transmit data empty interrupt (TXI) request and writes data to TDR. Similarly, the RDRF flag is cleared automatically when the DTC is initiated by a receive data full interrupt (RXI) and reads data from RDR.

Note: When switching from transmit or receive operation to simultaneous transmit and receive operations, first clear the TE bit and RE bit to 0, then set both these bits to 1 simultaneously.

Figure 14.23 Sample Flowchart of Simultaneous Serial Transmission and Reception

14.7 Smart Card Interface Description

The SCI supports the IC card (smart card) interface based on the ISO/IEC 7816-3 (Identification Card) standard as an enhanced serial communication interface function. Smart card interface mode can be selected using the appropriate register.

14.7.1 Sample Connection

Figure 14.24 shows a sample connection between the smart card and this LSI. As in the figure, since this LSI communicates with the IC card using a single transmission line, interconnect the Tx/D and Rx/D pins and pull up the data transmission line to VCC using a resistor. Setting the RE and TE bits in SCR to 1 with the IC card not connected enables closed transmission/reception allowing self diagnosis. To supply the IC card with the clock pulses generated by the SCI, input the SCK pin output to the CLK pin of the IC card. A reset signal can be supplied via the output port of this LSI.

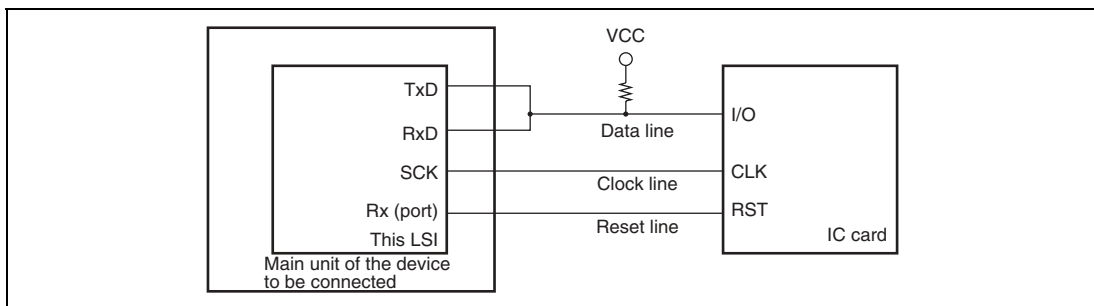

Figure 14.24 Pin Connection for Smart Card Interface

14.7.2 Data Format (Except in Block Transfer Mode)

Figure 14.25 shows the data transfer formats in smart card interface mode.

- One frame contains 8-bit data and a parity bit in asynchronous mode.
- During transmission, at least 2 etu (elementary time unit: time required for transferring one bit) is secured as a guard time after the end of the parity bit before the start of the next frame.
- If a parity error is detected during reception, a low error signal is output for 1 etu after 10.5 etu has passed from the start bit.
- If an error signal is sampled during transmission, the same data is automatically re-transmitted after two or more etu.

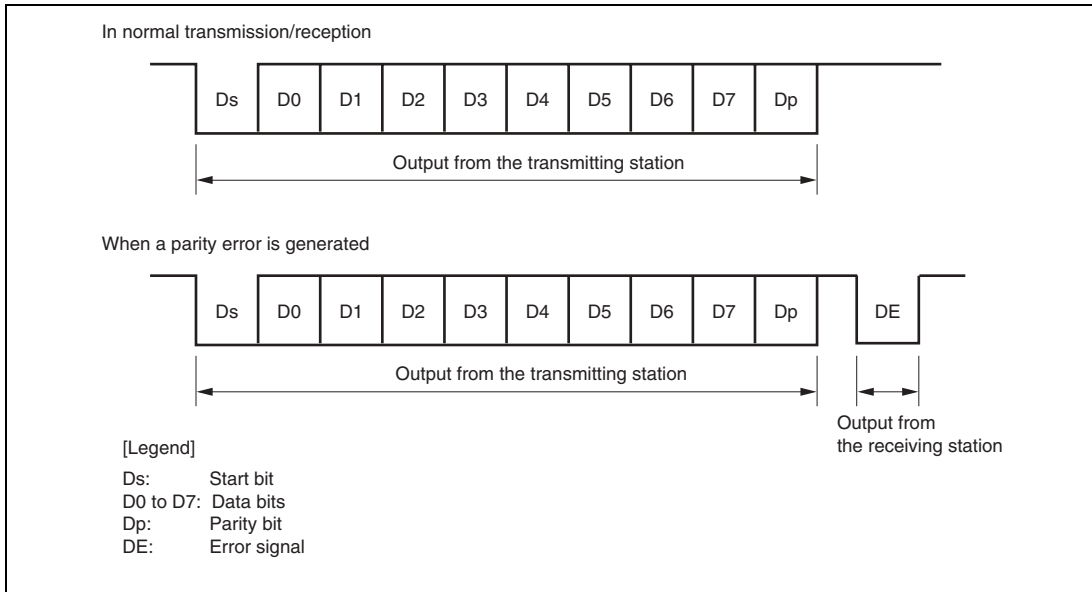

Figure 14.25 Data Formats in Normal Smart Card Interface Mode

For communication with the IC cards of the direct convention and inverse convention types, follow the procedure below.

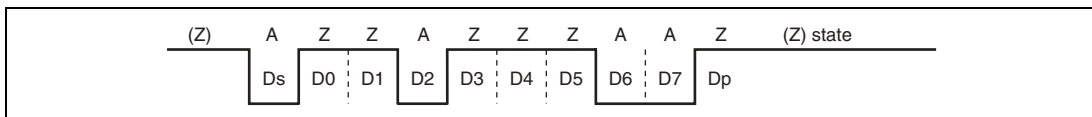

Figure 14.26 Direct Convention (SDIR = SINV = $O/\bar{E} = 0$)

For the direct convention type, logic levels 1 and 0 correspond to states Z and A, respectively, and data is transferred with LSB-first as the start character, as shown in figure 14.26. Therefore, data in the start character in the figure is H'3B. When using the direct convention type, write 0 to both the SDIR and SINV bits in SCMR. Write 0 to the O/\bar{E} bit in SMR in order to use even parity, which is prescribed by the smart card standard.

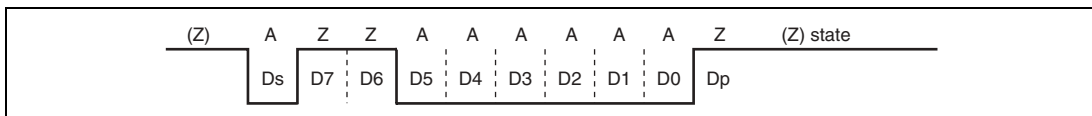

Figure 14.27 Inverse Convention (SDIR = SINV = $O/\bar{E} = 1$)

For the inverse convention type, logic levels 1 and 0 correspond to states A and Z, respectively and data is transferred with MSB-first as the start character, as shown in figure 14.27. Therefore, data in the start character in the figure is H'3F. When using the inverse convention type, write 1 to both the SDIR and SINV bits in SCMR. The parity bit is logic level 0 to produce even parity,

which is prescribed by the smart card standard, and corresponds to state Z. Since the SINV bit of this LSI only inverts data bits D7 to D0, write 1 to the O/E bit in SMR to invert the parity bit in both transmission and reception.

14.7.3 Block Transfer Mode

Block transfer mode is different from normal smart card interface mode in the following respects.

- If a parity error is detected during reception, no error signal is output. Since the PER bit in SSR is set by error detection, clear the bit before receiving the parity bit of the next frame.
- During transmission, at least 1 etu is secured as a guard time after the end of the parity bit before the start of the next frame.
- Since the same data is not re-transmitted during transmission, the TEND flag in SSR is set 11.5 etu after transmission start.
- Although the ERS flag in block transfer mode displays the error signal status as in normal smart card interface mode, the flag is always read as 0 because no error signal is transferred.

14.7.4 Receive Data Sampling Timing and Reception Margin

Only the internal clock generated by the internal baud rate generator can be used as a communication clock in smart card interface mode. In this mode, the SCI can operate using a basic clock with a frequency of 32, 64, 372, or 256 times the bit rate according to the BCP1 and BCP0 settings (the frequency is always 16 times the bit rate in normal asynchronous mode). At reception, the falling edge of the start bit is sampled using the internal basic clock in order to perform internal synchronization. Receive data is sampled at the 16th, 32nd, 186th and 128th rising edges of the basic clock pulses so that it can be latched at the center of each bit as shown in figure 14.28. The reception margin here is determined by the following formula.

$$M = \left| \left(0.5 - \frac{1}{2N} \right) - (L - 0.5) F - \frac{|D - 0.5|}{N} (1 + F) \right| \times 100 [\%] \quad \cdots \text{Formula (1)}$$

M: Reception margin (%)

N: Ratio of bit rate to clock (N = 32, 64, 372, 256)

D: Clock duty (D = 0 to 1.0)

L: Frame length (L = 10)

F: Absolute value of clock rate deviation

Assuming values of F = 0, D = 0.5, and N = 372 in formula (1), the reception margin is determined by the formula below.

$$M = (0.5 - 1/2 \times 372) \times 100 [\%] = 49.866\%$$

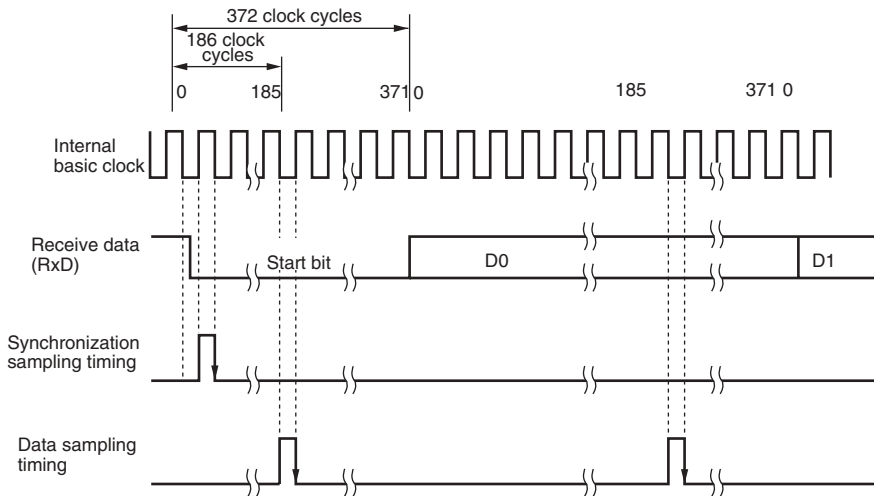

Figure 14.28 Receive Data Sampling Timing in Smart Card Interface Mode (When Clock Frequency is 372 Times the Bit Rate)

14.7.5 Initialization

Before starting transmitting and receiving data, initialize the SCI using the following procedure. Initialization is also necessary before switching from transmission to reception and vice versa.

1. Clear the TE and RE bits in SCR to 0.
2. Clear the error flags ORER, ERS, and PER in SSR to 0.
3. Set the GM, BLK, O/\bar{E} , BCP1, BCP0, CKS1, and CKS0 bits in SMR appropriately. Also set the PE bit to 1.
4. Set the SMIF, SDIR, and SINV bits in SCMR appropriately. When the SMIF bit is set to 1, the TxD and RxD pins are changed from port pins to SCI pins, placing the pins into high impedance state.
5. Set the value corresponding to the bit rate in BRR.
6. Set the CKE1 and CKE0 bits in SCR appropriately. Clear the TIE, RIE, TE, RE, MPIE, and TEIE bits to 0 simultaneously. When the CKE0 bit is set to 1, the SCK pin is allowed to output clock pulses.
7. Set the TIE, RIE, TE, and RE bits in SCR appropriately after waiting for at least 1 bit interval. Setting prohibited the TE and RE bits to 1 simultaneously except for self diagnosis.

To switch from reception to transmission, first verify that reception has completed, and initialize the SCI. At the end of initialization, RE and TE should be set to 0 and 1, respectively. Reception completion can be verified by reading the RDRF flag or PER and ORER flags. To switch from transmission to reception, first verify that transmission has completed, and initialize the SCI. At

the end of initialization, TE and RE should be set to 0 and 1, respectively. Transmission completion can be verified by reading the TEND flag.

14.7.6 Serial Data Transmission (Except in Block Transfer Mode)

Data transmission in smart card interface mode (except in block transfer mode) is different from that in normal serial communication interface mode in that an error signal is sampled and data is re-transmitted. Figure 14.29 shows the data re-transfer operation during transmission.

1. If an error signal from the receiving end is sampled after one frame of data has been transmitted, the ERS bit in SSR is set to 1. Here, an ERI interrupt request is generated if the RIE bit in SCR is set to 1. Clear the ERS bit to 0 before the next parity bit is sampled.
2. For the frame in which an error signal is received, the TEND bit in SSR is not set to 1. Data is re-transferred from TDR to TSR allowing automatic data retransmission.
3. If no error signal is returned from the receiving end, the ERS bit in SSR is not set to 1. In this case, one frame of data is determined to have been transmitted including re-transfer, and the TEND bit in SSR is set to 1. Here, a TXI interrupt request is generated if the TIE bit in SCR is set to 1. Writing transmit data to TDR starts transmission of the next data.

Figure 14.31 shows a sample flowchart for transmission. All the processing steps are automatically performed using a TXI interrupt request to activate the DTC. In transmission, the TEND and TDRE flags in SSR are simultaneously set to 1, thus generating a TXI interrupt request when TIE in SCR is set. This activates the DTC by a TXI request thus allowing transfer of transmit data if the TXI interrupt request is specified as a source of DTC activation beforehand. The TDRE and TEND flags are automatically cleared to 0 at data transfer by the DTC. If an error occurs, the SCI automatically re-transmits the same data. During re-transmission, TEND remains as 0, thus not activating the DTC. Therefore, the SCI and DTC automatically transmit the specified number of bytes, including re-transmission in the case of error occurrence. However, the ERS flag is not automatically cleared; the ERS flag must be cleared by previously setting the RIE bit to 1 to enable an ERI interrupt request to be generated at error occurrence.

When transmitting/receiving data using the DTC, be sure to set and enable it prior to making SCI settings. For DTC settings, see section 7, Data Transfer Controller (DTC).

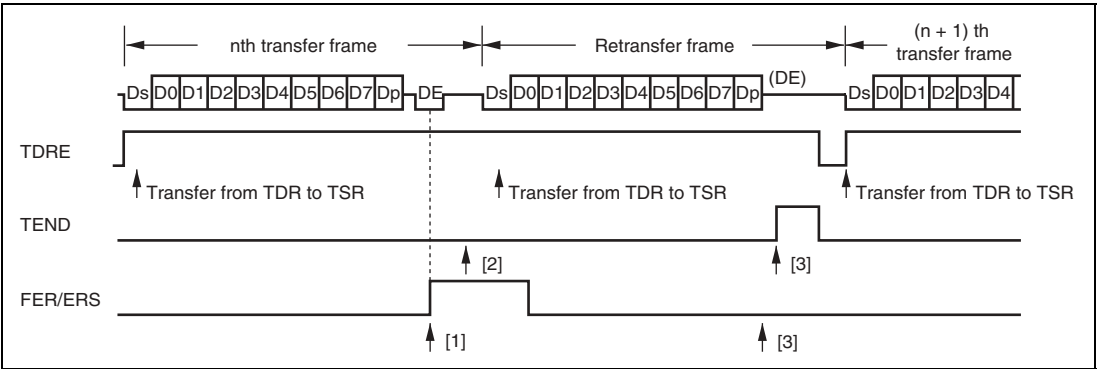

Figure 14.29 Data Re-transfer Operation in SCI Transmission Mode

Note that the TEND flag is set in different timings depending on the GM bit setting in SMR, which is shown in figure 14.30.

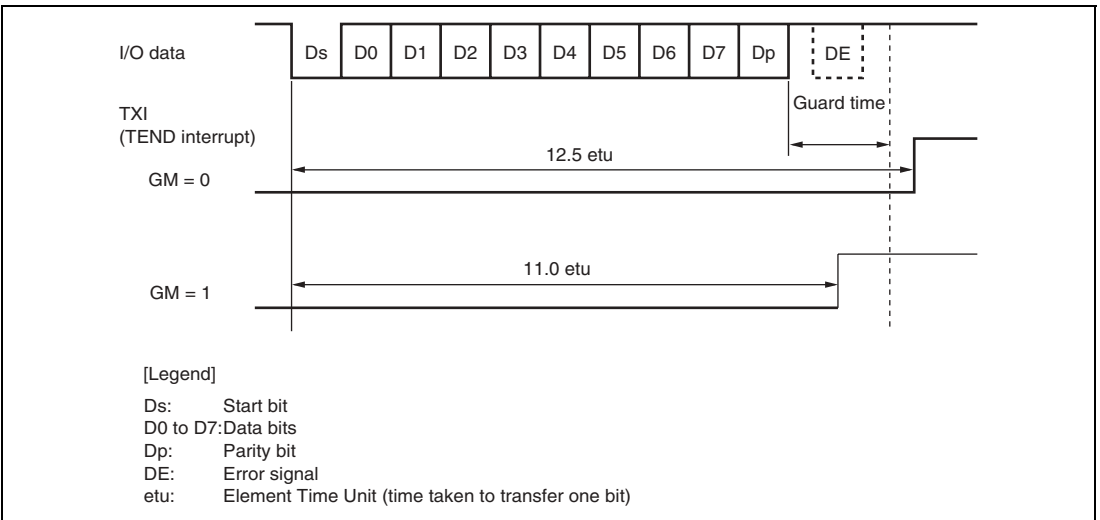

Figure 14.30 TEND Flag Set Timings during Transmission

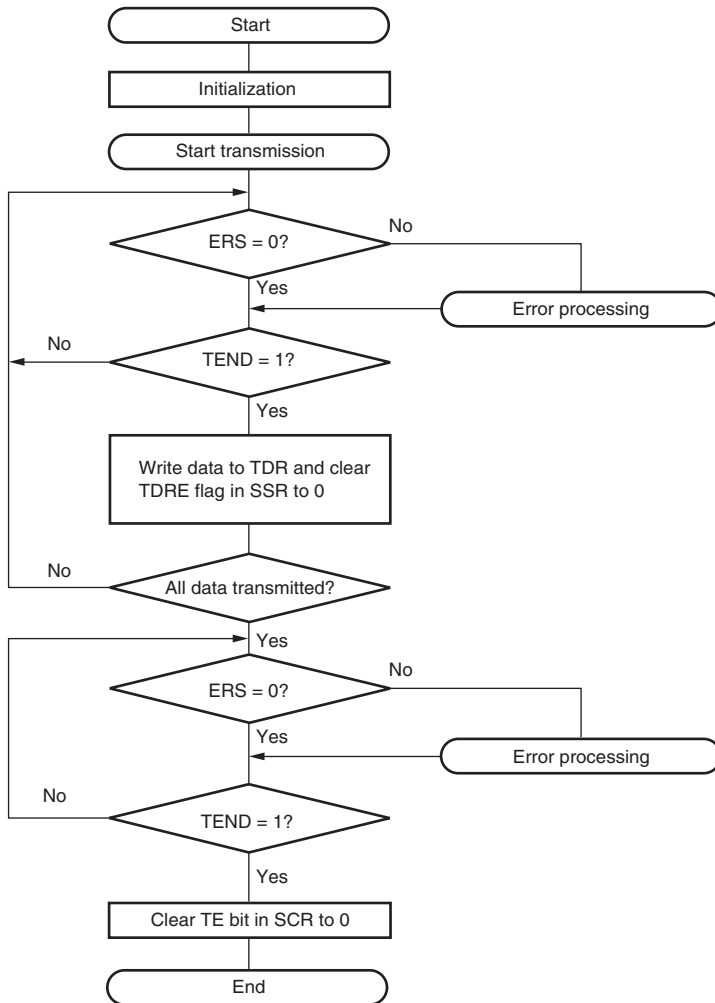

Figure 14.31 Sample Transmission Flowchart

14.7.7 Serial Data Reception (Except in Block Transfer Mode)

Data reception in smart card interface mode is identical to that in normal serial communication interface mode. Figure 14.32 shows the data re-transfer operation during reception.

1. If a parity error is detected in receive data, the PER bit in SSR is set to 1. Here, an ERI interrupt request is generated if the RIE bit in SCR is set to 1. Clear the PER bit to 0 before the next parity bit is sampled.
2. For the frame in which a parity error is detected, the RDRF bit in SSR is not set to 1.
3. If no parity error is detected, the PER bit in SSR is not set to 1. In this case, data is determined to have been received successfully, and the RDRF bit in SSR is set to 1. Here, an RXI interrupt request is generated if the RIE bit in SCR is set.

Figure 14.33 shows a sample flowchart for reception. All the processing steps are automatically performed using an RXI interrupt request to activate the DTC. In reception, setting the RIE bit to 1 allows an RXI interrupt request to be generated when the RDRF flag is set to 1. This activates DTC by an RXI request thus allowing transfer of receive data if the RXI interrupt request is specified as a source of DTC activate beforehand. The RDRF flag is automatically cleared to 0 at data transfer by DTC. If an error occurs during reception, i.e., either the ORE or PER flag is set to 1, a transmit/receive error interrupt (ERI) request is generated and the error flag must be cleared. If an error occurs, DTC is not activated and receive data is skipped, therefore, the number of bytes of receive data specified in DTC are transferred. Even if a parity error occurs and PER is set to 1 in reception, receive data is transferred to RDR, thus allowing the data to be read.

Note: For operations in block transfer mode, see section 14.4, Operation in Asynchronous Mode.

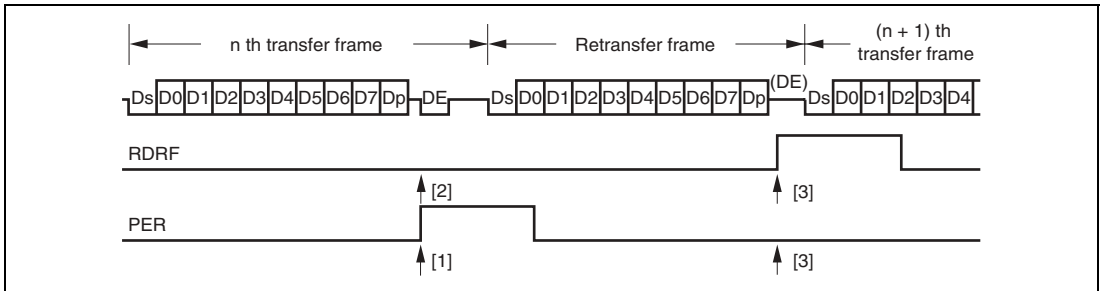

Figure 14.32 Data Re-transfer Operation in SCI Reception Mode

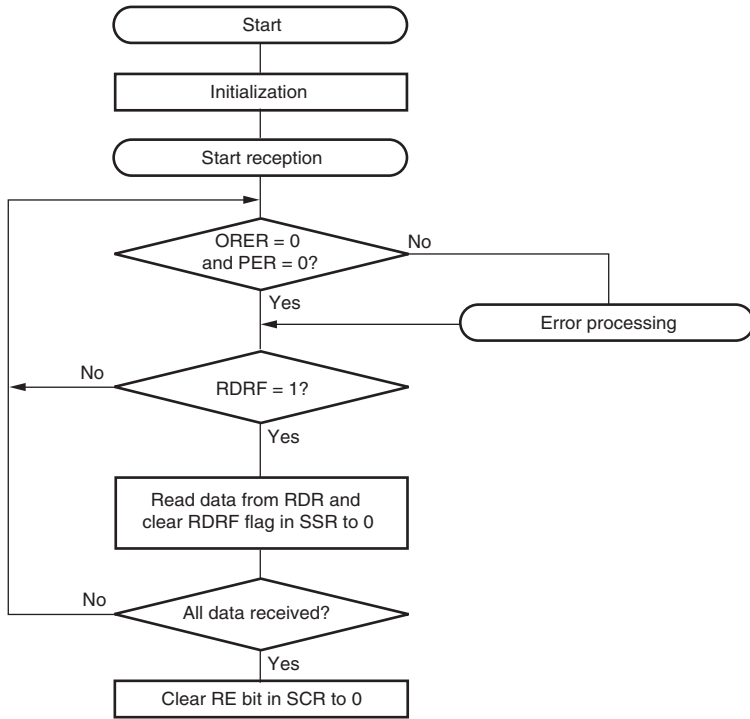

Figure 14.33 Sample Reception Flowchart

14.7.8 Clock Output Control

Clock output can be fixed using the CKE1 and CKE0 bits in SCR when the GM bit in SMR is set to 1. Specifically, the minimum width of a clock pulse can be specified.

Figure 14.34 shows an example of clock output fixing timing when the CKE0 bit is controlled with GM = 1 and CKE1 = 0.

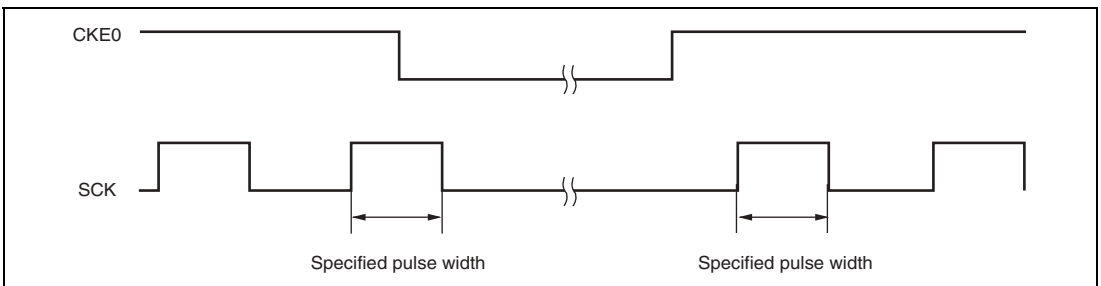

Figure 14.34 Clock Output Fixing Timing

At power-on and transitions to/from software standby mode, use the following procedure to secure the appropriate clock duty ratio.

At Power-On:

To secure the appropriate clock duty ratio simultaneously with power-on, use the following procedure.

1. Initially, port input is enabled in the high-impedance state. To fix the potential level, use a pull-up or pull-down resistor.
2. Fix the SCK pin to the specified output using the CKE1 bit in SCR.
3. Set SMR and SCMR to enable smart card interface mode.
4. Set the CKE0 bit in SCR to 1 to start clock output.

At Transition from Smart Card Interface Mode to Software Standby Mode:

1. Set the port data register (DR) and data direction register (DDR) corresponding to the SCK pins to the values for the output fixed state in software standby mode.
2. Write 0 to the TE and RE bits in SCR to stop transmission/reception. Simultaneously, set the CKE1 bit to the value for the output fixed state in software standby mode.
3. Write 0 to the CKE0 bit in SCR to stop the clock.
4. Wait for one cycle of the serial clock. In the mean time, the clock output is fixed to the specified level with the duty ratio retained.
5. Make the transition to software standby mode.

At Transition from Software Standby Mode to Smart Card Interface Mode:

1. Cancel software standby mode.
2. Write 1 to the CKE0 bit in SCR to start clock output. A clock signal with the appropriate duty ratio is then generated.

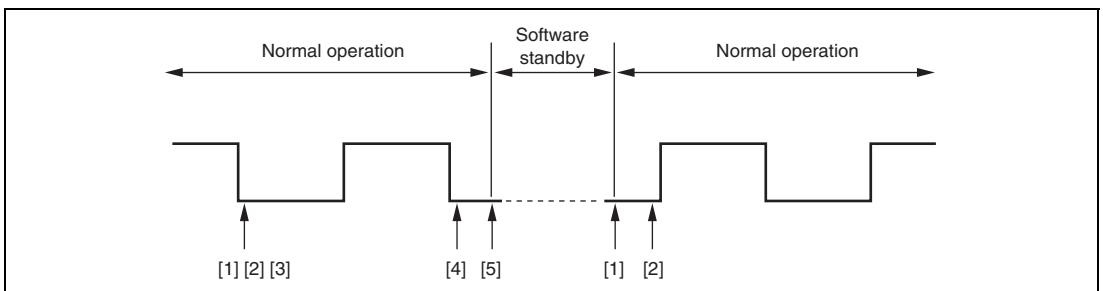

Figure 14.35 Clock Stop and Restart Procedure

14.8 IrDA Operation

IrDA operation can be used with SCI_1. Figure 14.36 shows an IrDA block diagram.

If the IrDA function is enabled using the IrE bit in SCICR, the TxD1 and RxD1 signals for SCI_1 are allowed to encode and decode the waveform based on the IrDA standard version 1.0 (function as the IrTxD and IrRxD pins). Connecting these pins to the infrared data transceiver achieves infrared data communication based on the system defined by the IrDA standard version 1.0.

In the system defined by the IrDA standard version 1.0, communication is started at a transfer rate of 9600 bps, which can be modified as required. The IrDA interface provided by this LSI does not incorporate the capability of automatic modification of the transfer rate; the transfer rate must be modified through programming.

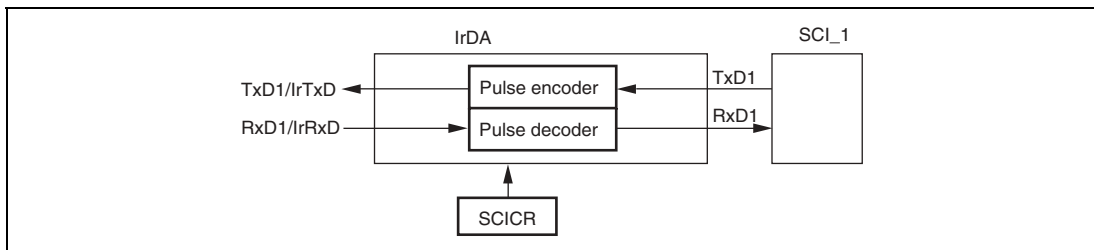

Figure 14.36 IrDA Block Diagram

Transmission: During transmission, the output signals from the SCI (UART frames) are converted to IR frames using the IrDA interface (see figure 14.37).

For serial data of level 0, a high-level pulse having a width of $3/16$ of the bit rate (1-bit interval) is output (initial setting). The high-level pulse can be selected using the IrCKS2 to IrCKS0 bits in SCICR.

The high-level pulse width is defined to be $1.41 \mu\text{s}$ at minimum and $(3/16 + 2.5\%) \times \text{bit rate}$ or $(3/16 \times \text{bit rate}) + 1.08 \mu\text{s}$ at maximum. For example, when the frequency of system clock ϕ is 20 MHz, a high-level pulse width of at least $1.41 \mu\text{s}$ to $1.6 \mu\text{s}$ can be specified.

For serial data of level 1, no pulses are output.

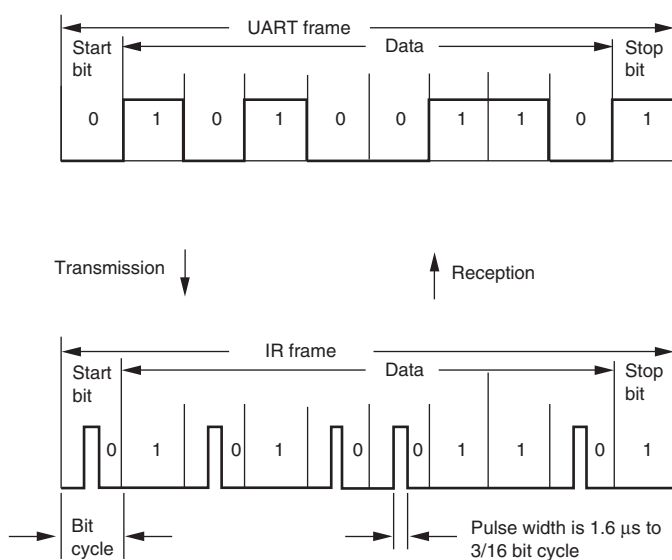

Figure 14.37 IrDA Transmission and Reception

Reception: During reception, IR frames are converted to UART frames using the IrDA interface before inputting to SCI_1.

Data of level 0 is output each time a high-level pulse is detected and data of level 1 is output when no pulse is detected in a bit cycle. If a pulse has a high-level width of less than 1.41 μs, the minimum width allowed, the pulse is recognized as level 0.

High-Level Pulse Width Selection: Table 14.13 shows possible settings for bits IrCKS2 to IrCKS0 (minimum pulse width), and this LSI's operating frequencies and bit rates, for making the pulse width shorter than 3/16 times the bit rate in transmission.

Table 14.13 IrCKS2 to IrCKS0 Bit Settings

Operating Frequency ϕ (MHz)	Bit Rate (bps) (Upper Row) / Bit Interval \times 3/16 (μ s) (Lower Row)					
	2400	9600	19200	38400	57600	115200
	78.13	19.53	9.77	4.88	3.26	1.63
5	011	011	011	011	011	011
6	100	100	100	100	100	100
6.144	100	100	100	100	100	100
7.3728	100	100	100	100	100	100
8	100	100	100	100	100	100
9.8304	100	100	100	100	100	100
10	100	100	100	100	100	100
12	101	101	101	101	101	101
12.288	101	101	101	101	101	101
14	101	101	101	101	101	101
14.7456	101	101	101	101	101	101
16	101	101	101	101	101	101
16.9344	101	101	101	101	101	101
17.2032	101	101	101	101	101	101
18	101	101	101	101	101	101
19.6608	101	101	101	101	101	101
20	101	101	101	101	101	101
25	110	110	110	110	110	110
33	110	110	110	110	110	110

14.9 Interrupt Sources

14.9.1 Interrupts in Normal Serial Communication Interface Mode

Table 14.13 shows the interrupt sources in normal serial communication interface mode. A different interrupt vector is assigned to each interrupt source, and individual interrupt sources can be enabled or disabled using the enable bits in SCR.

When the TDRE flag in SSR is set to 1, a TXI interrupt request is generated. When the TEND flag in SSR is set to 1, a TEI interrupt request is generated. A TXI interrupt can activate the DTC to allow data transfer. The TDRE flag is automatically cleared to 0 at data transfer by the DTC.

When the RDRF flag in SSR is set to 1, an RXI interrupt request is generated. When the ORER, PER, or FER flag in SSR is set to 1, an ERI interrupt request is generated. An RXI interrupt can activate the DTC to allow data transfer. The RDRF flag is automatically cleared to 0 at data transfer by the DTC.

A TEI interrupt is requested when the TEND flag is set to 1 while the TEIE bit is set to 1. If a TEI interrupt and a TXI interrupt are requested simultaneously, the TXI interrupt has priority for acceptance. However, note that if the TDRE and TEND flags are cleared simultaneously by the TXI interrupt routine, the SCI cannot branch to the TEI interrupt routine later.

Table 14.14 SCI Interrupt Sources

Channel	Name	Interrupt Source	Interrupt Flag	DTC Activation	Priority
0	ERI0	Receive error	ORER, FER, PER	Not possible	High ↑
	RXI0	Receive data full	RDRF	Possible	
	TXI0	Transmit data empty	TDRE	Possible	
	TEI0	Transmit end	TEND	Not possible	
1	ERI1	Receive error	ORER, FER, PER	Not possible	↑
	RXI1	Receive data full	RDRF	Possible	
	TXI1	Transmit data empty	TDRE	Possible	
	TEI1	Transmit end	TEND	Not possible	
2	ERI2	Receive error	ORER, FER, PER	Not possible	↑
	RXI2	Receive data full	RDRF	Possible	
	TXI2	Transmit data empty	TDRE	Possible	
	TEI2	Transmit end	TEND	Not possible	

14.10 Usage Notes

14.10.1 Module Stop Mode Setting

SCI operation can be disabled or enabled using the module stop control register. The initial setting is for SCI operation to be halted. Register access is enabled by clearing module stop mode. For details, see section 23, Power-Down Modes.

14.10.2 Break Detection and Processing

When framing error detection is performed, a break can be detected by reading the RxD pin value directly. In a break, the input from the RxD pin becomes all 0s, and so the FER flag in SSR is set, and the PER flag may also be set. Note that, since the SCI continues the receive operation even after receiving a break, even if the FER flag is cleared to 0, it will be set to 1 again.

14.10.3 Mark State and Break Sending

When the TE bit in SCR is 0, the TxD pin is used as an I/O port whose direction (input or output) and level are determined by DR and DDR of the port. This can be used to set the TxD pin to mark state (high level) or send a break during serial data transmission. To maintain the communication line at mark state until TE is set to 1, set both DDR and DR to 1. Since the TE bit is cleared to 0 at this point, the TxD pin becomes an I/O port, and 1 is output from the TxD pin. To send a break during serial transmission, first set DDR to 1 and DR to 0, and then clear the TE bit to 0. When the TE bit is cleared to 0, the transmitter is initialized regardless of the current transmission state, the TxD pin becomes an I/O port, and 0 is output from the TxD pin.

14.10.4 Receive Error Flags and Transmit Operations (Clock Synchronous Mode Only)

Transmission cannot be started when a receive error flag (ORER, FER, or RER) in SSR is set to 1, even if the TDRE flag in SSR is cleared to 0. Be sure to clear the receive error flags to 0 before starting transmission. Note also that the receive error flags cannot be cleared to 0 even if the RE bit in SCR is cleared to 0.

14.10.5 Relation between Writing to TDR and TDRE Flag

Data can be written to TDR irrespective of the TDRE flag status in SSR. However, if the new data is written to TDR when the TDRE flag is 0, that is, when the previous data has not been transferred to TSR yet, the previous data in TDR is lost. Be sure to write transmit data to TDR after verifying that the TDRE flag is set to 1.

14.10.6 Restrictions on Using DTC

When the external clock source is used as a synchronization clock, update TDR by the DTC and wait for at least five ϕ clock cycles before allowing the transmit clock to be input. If the transmit clock is input within four clock cycles after TDR modification, the SCI may malfunction (figure 14.38).

When using the DTC to read RDR, be sure to set the receive end interrupt source (RXI) as a DTC activation source.

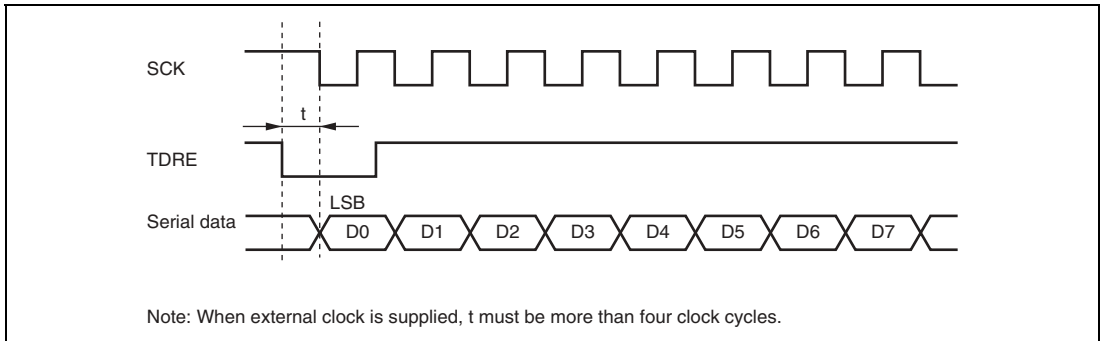

Figure 14.38 Sample Transmission using DTC in Clock Synchronous Mode

14.10.7 SCI Operations during Mode Transitions

Transmission: Before making the transition to module stop, software standby, or sub-sleep mode, stop all transmit operations ($TE = TIE = TEIE = 0$). TSR, TDR, and SSR are reset. The states of the output pins during each mode depend on the port settings, and the pins output a high-level signal after mode cancellation. If the transition is made during data transmission, the data being transmitted will be undefined.

To transmit data in the same transmission mode after mode cancellation, set TE to 1, read SSR, write to TDR, clear TDRE in this order, and then start transmission. To transmit data in a different transmission mode, initialize the SCI first.

Figure 14.39 shows a sample flowchart for mode transition during transmission. Figures 14.40 and 14.41 show the pin states during transmission.

Before making the transition from the transmission mode using DTC transfer to module stop, software standby, or sub-sleep mode, stop all transmit operations ($TE = TIE = TEIE = 0$). Setting TE and TIE to 1 after mode cancellation generates a TXI interrupt request to start transmission using the DTC.

Reception: Before making the transition to module stop, software standby, watch, sub-active, or sub-sleep mode, stop reception ($RE = 0$). RSR, RDR, and SSR are reset. If transition is made during data reception, the data being received will be invalid.

To receive data in the same reception mode after mode cancellation, set RE to 1, and then start reception. To receive data in a different reception mode, initialize the SCI first.

Figure 14.42 shows a sample flowchart for mode transition during reception.

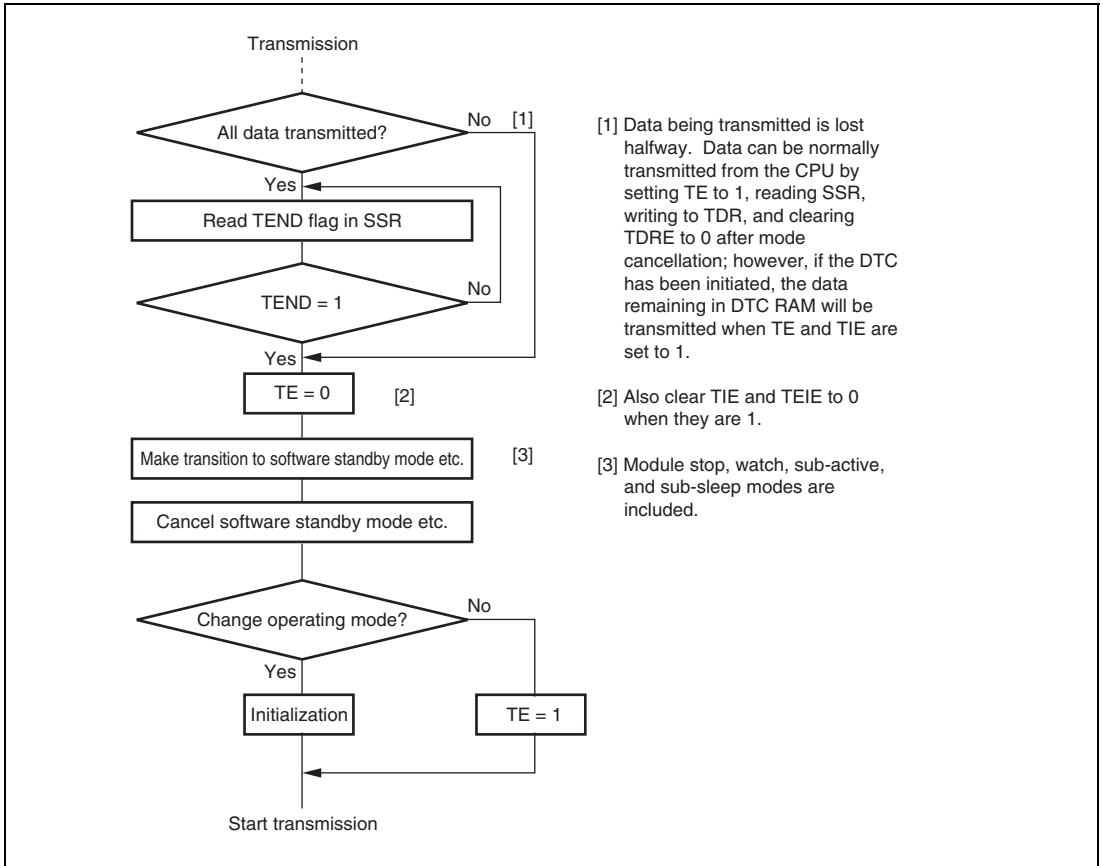

Figure 14.39 Sample Flowchart for Mode Transition during Transmission

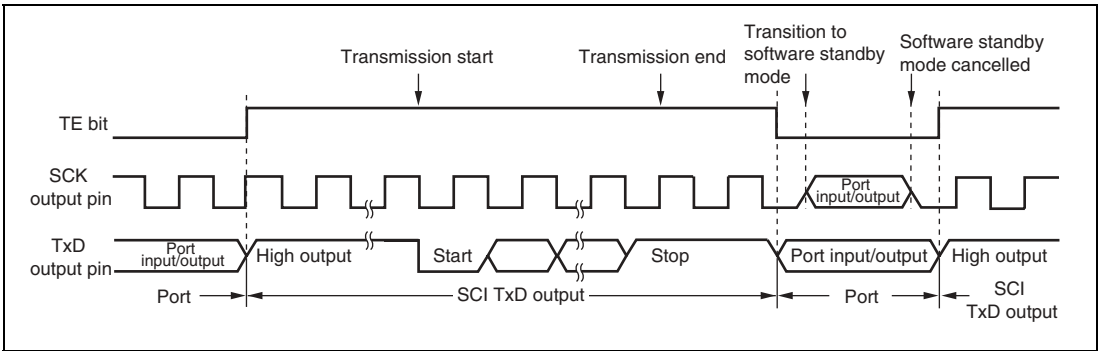

Figure 14.40 Pin States during Transmission in Asynchronous Mode (Internal Clock)

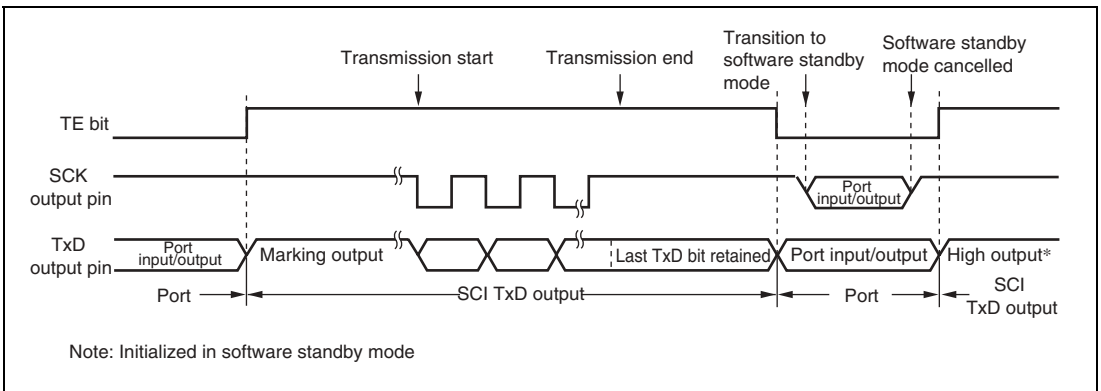

Figure 14.41 Pin States during Transmission in Clock Synchronous Mode (Internal Clock)

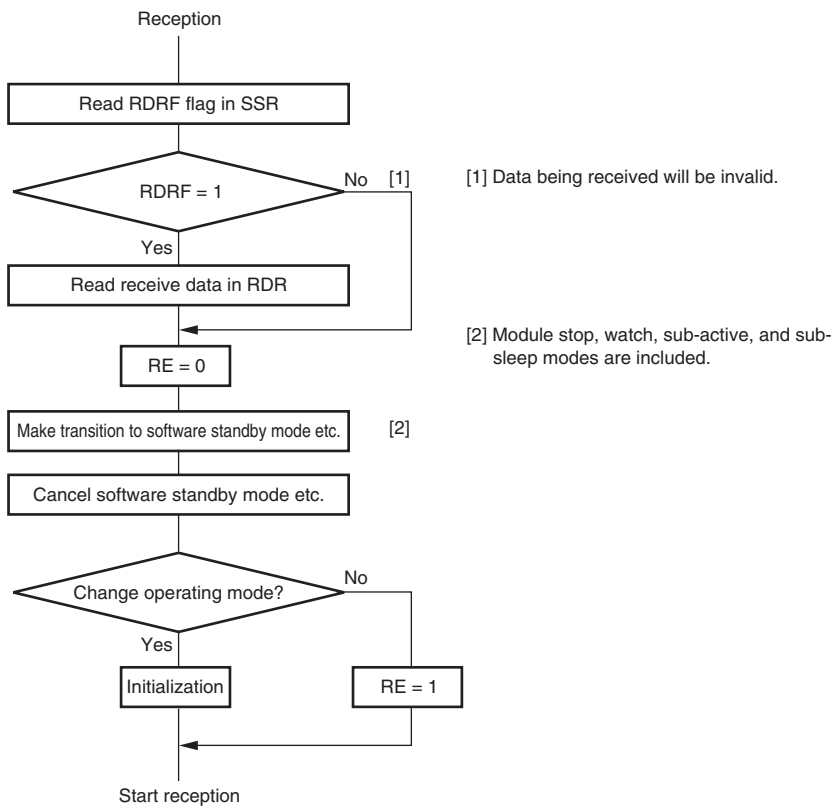

Figure 14.42 Sample Flowchart for Mode Transition during Reception

14.10.8 Notes on Switching from SCK Pins to Port Pins

When SCK pins are switched to port pins after transmission has completed, pins are enabled for port output after outputting a low pulse of half a cycle as shown in figure 14.43.

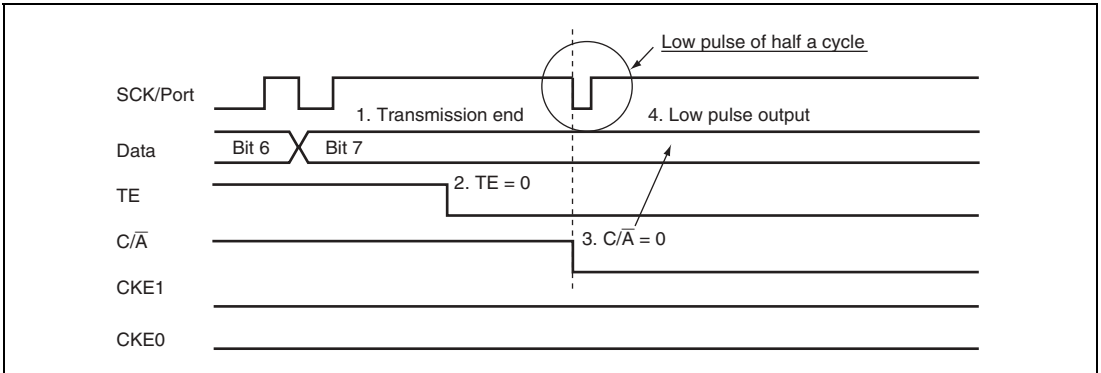

Figure 14.43 Switching from SCK Pins to Port Pins

To prevent the low pulse output that is generated when switching the SCK pins to the port pins, specify the SCK pins for input (pull up the SCK/port pins externally), and follow the procedure below with $DDR = 1$, $DR = 1$, $C/\bar{A} = 1$, $CKE1 = 0$, $CKE1 = 0$, and $TE = 1$.

1. End serial data transmission
2. TE bit = 0
3. CKE1 bit = 1
4. C/\bar{A} bit = 0 (switch to port output)
5. CKE1 bit = 0

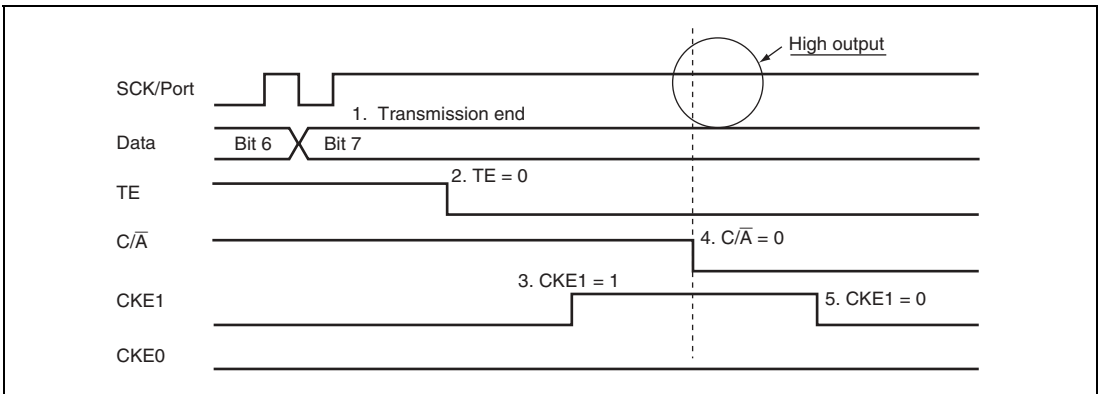

Figure 14.44 Prevention of Low Pulse Output at Switching from SCK Pins to Port Pins

14.11 CRC Operation Circuit

The cyclic redundancy check (CRC) operation circuit detects errors in data blocks.

14.11.1 Features

The features of the CRC operation circuit are listed below.

- CRC code generated for any desired data length in an 8-bit unit
- CRC operation executed on eight bits in parallel
- One of three generating polynomials selectable
- CRC code generation for LSB-first or MSB-first communication selectable

Figure 14.45 shows a block diagram of the CRC operation circuit.

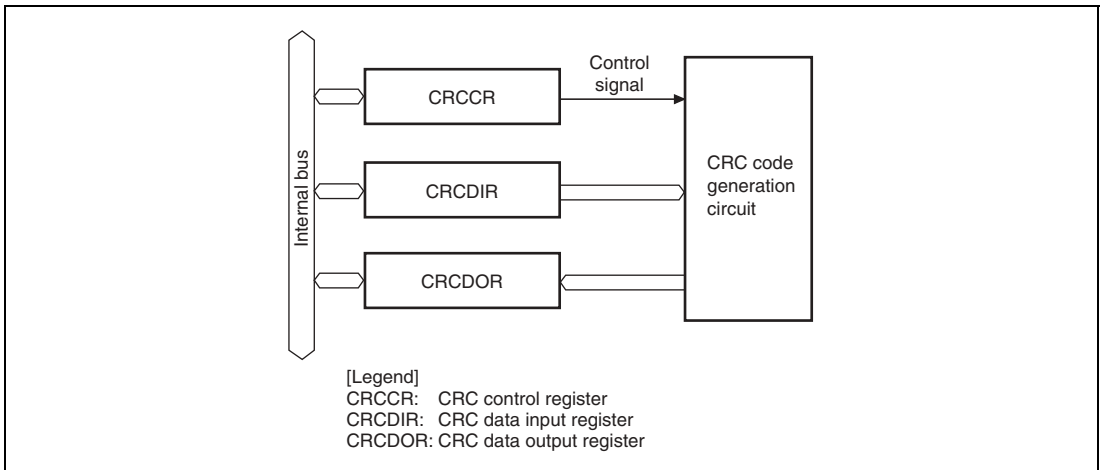

Figure 14.45 Block Diagram of CRC Operation Circuit

14.11.2 Register Descriptions

The CRC operation circuit has the following registers.

- CRC control register (CRCCR)
- CRC data input register (CRCDIR)
- CRC data output register (CRCDOR)

CRC Control Register (CRCCR): CRCCR initializes the CRC operation circuit, switches the operation mode, and selects the generating polynomial.

Bit	Bit Name	Initial Value	R/W	Description
7	DORCLR	0	W	CRCDOR Clear Setting this bit to 1 clears CRCDOR to H'0000.
6 to 3	—	All 0	R	Reserved The initial value should not be changed.
2	LMS	0	R/W	CRC Operation Switch Selects CRC code generation for LSB-first or MSB-first communication. 0: Performs CRC operation for LSB-first communication. The lower byte (bits 7 to 0) is first transmitted when CRCDOR contents (CRC code) are divided into two bytes to be transmitted in two parts. 1: Performs CRC operation for MSB-first communication. The upper byte (bits 15 to 8) is first transmitted when CRCDOR contents (CRC code) are divided into two bytes to be transmitted in two parts.
1	G1	0	R/W	CRC Generating Polynomial Select These bits select the polynomial. 00: Reserved 01: $X^3 + X^2 + X + 1$ 10: $X^{16} + X^{15} + X^2 + 1$ 11: $X^{16} + X^{12} + X^5 + 1$
0	G0	0	R/W	

CRC Data Input Register (CRCDIR): CRCDIR is an 8-bit readable/writable register, to which the bytes to be CRC-operated are written. The result is obtained in CRCDOR.

CRC Data Output Register (CRCDOR): CRCDOR is a 16-bit readable/writable register that contains the result of CRC operation when the bytes to be CRC-operated are written to CRCDIR after CRCDOR is cleared. When the CRC operation result is additionally written to the bytes to which CRC operation is to be performed, the CRC operation result will be H'0000 if the data contains no CRC error. When bits 1 and 0 in CRCCR (G1 and G0 bits) are set to 0 and 1, respectively, the lower byte of this register contains the result.

14.11.3 CRC Operation Circuit Operation

The CRC operation circuit generates a CRC code for LSB-first/MSB-first communications. An example in which a CRC code for hexadecimal data H'F0 is generated using the $X^{16} + X^{12} + X^5 + 1$ polynomial with the G1 and G0 bits in CRCCR set to B'11 is shown below.

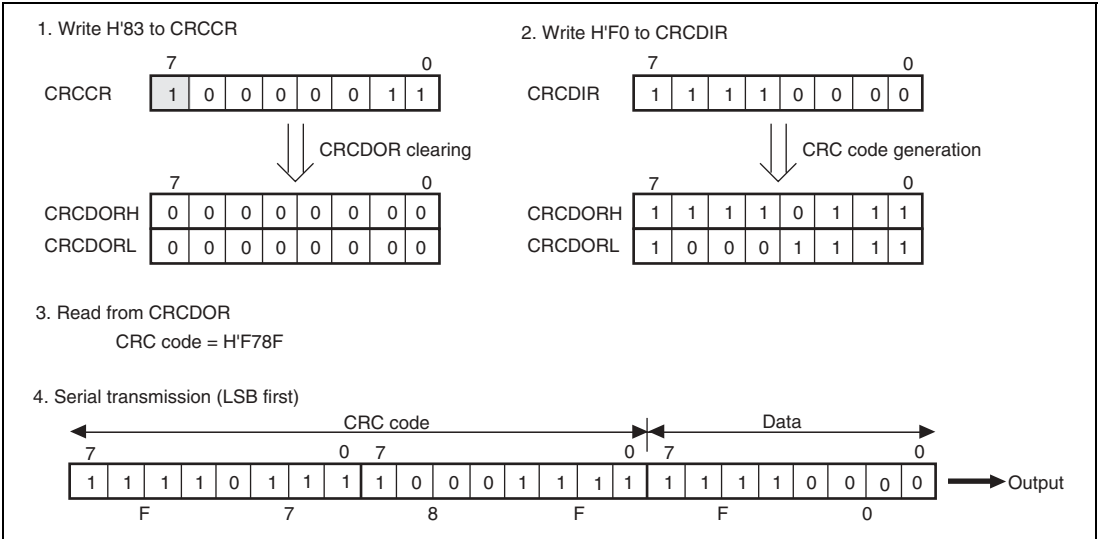

Figure 14.46 LSB-First Data Transmission

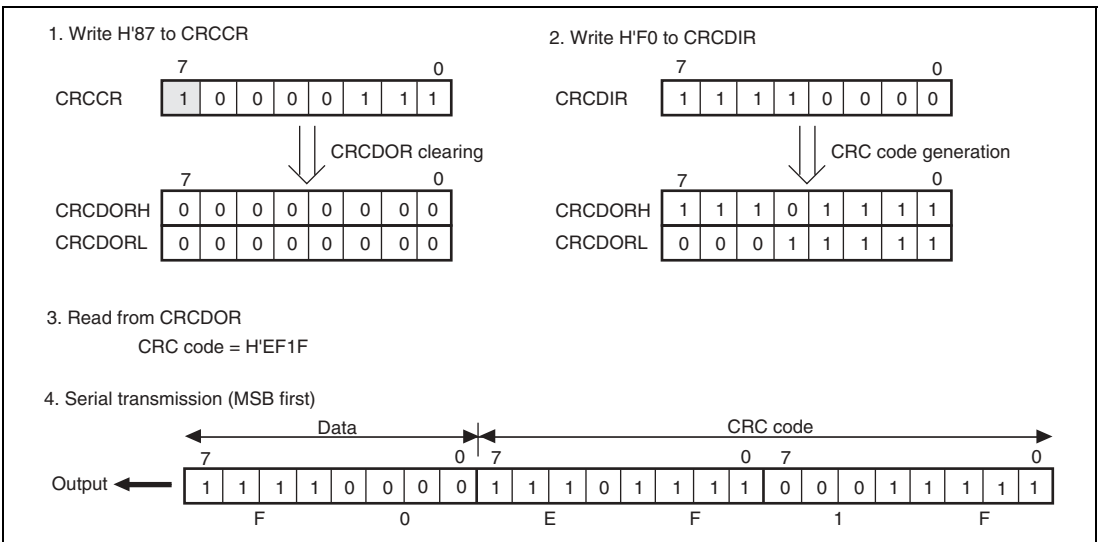
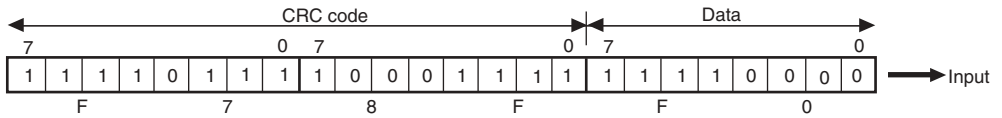
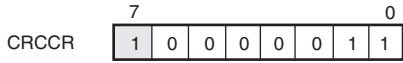

Figure 14.47 MSB-First Data Transmission

1. Serial reception (LSB first)



2. Write H'83 to CRCCR



CRCDOR clearing

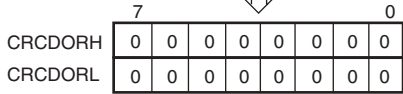

3. Write H'F0 to CRCDIR

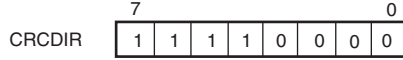

CRC code generation

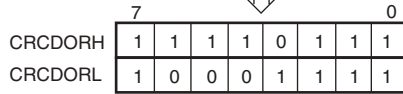

4. Write H'8F to CRCDIR

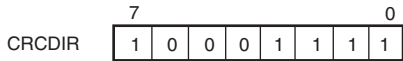

CRC code generation



5. Write H'F7 to CRCDIR

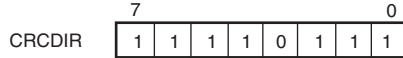

CRC code generation



6. Read from CRCDOR

CRC code = H'0000 → No error

Figure 14.48 LSB-First Data Reception

1. Serial reception (MSB first)

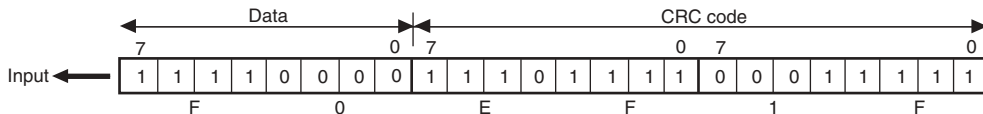

2. Write H'87 to CRCCLR

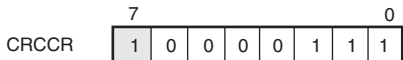

CRCDOR clearing

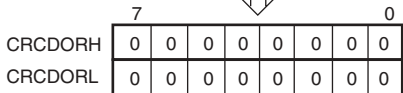

3. Write H'F0 to CRCDIR

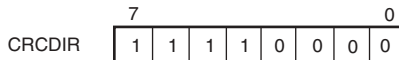

CRC code generation



4. Write H'EF to CRCDIR

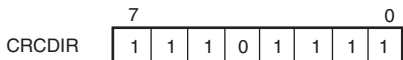

CRC code generation

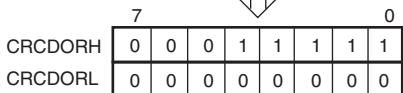

5. Write H'1F to CRCDIR

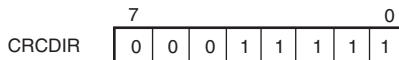

CRC code generation

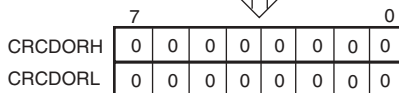

6. Read from CRCDOR

CRC code = H'0000 → No error

Figure 14.49 MSB-First Data Reception

14.11.4 Note on CRC Operation Circuit

Note that the sequence to transmit the CRC code differs between LSB-first transmission and MSB-first transmission.

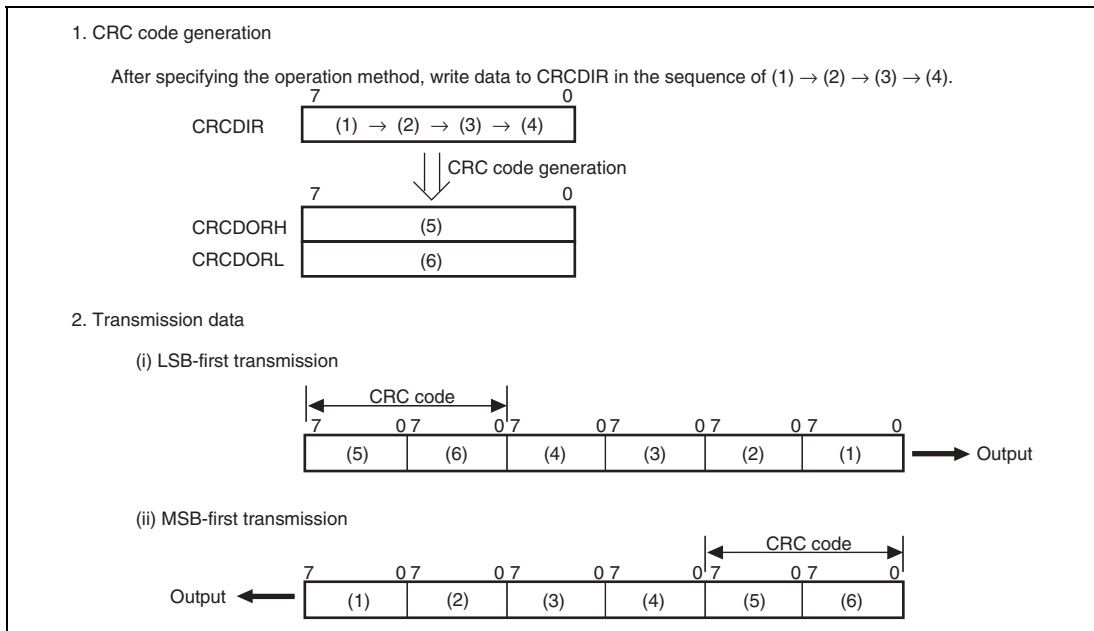

Figure 14.50 LSB-First and MSB-First Transmit Data

Section 15 I²C Bus Interface (IIC)

This LSI has a six-channel I²C bus interface (IIC). The I²C bus interface conforms to and provides a subset of the Philips I²C bus (inter-IC bus) interface functions. The register configuration that controls the I²C bus differs partly from the Philips configuration, however.

15.1 Features

- Selection of addressing format or non-addressing format
 - I²C bus format: addressing format with acknowledge bit, for master/slave operation
 - Clocked synchronous serial format: non-addressing format without acknowledge bit, for master operation only
- Conforms to Philips I²C bus interface (I²C bus format)
- Two ways of setting slave address (I²C bus format)
- Start and stop conditions generated automatically in master mode (I²C bus format)
- Selection of acknowledge output levels when receiving (I²C bus format)
- Automatic loading of acknowledge bit when transmitting (I²C bus format)
- Wait function in master mode (I²C bus format)
 - A wait can be inserted by driving the SCL pin low after data transfer, excluding acknowledgement.
 - The wait can be cleared by clearing the interrupt flag.
- Wait function (I²C bus format)
 - A wait request can be generated by driving the SCL pin low after data transfer.
 - The wait request is cleared when the next transfer becomes possible.
- Interrupt sources
 - Data transfer end (including when a transition to transmit mode with I²C bus format occurs, when ICDR data is transferred, or during a wait state)
 - Address match: when any slave address matches or the general call address is received in slave receive mode with I²C bus format (including address reception after loss of master arbitration)
 - Arbitration loss
 - Start condition detection (in master mode)
 - Stop condition detection (in slave mode)
- Selection of 32 internal clocks (in master mode)
- Direct bus drive
 - Pins—SCL0 to SCL5 and SDA0 to SDA5 —(normally NMOS push-pull outputs) function as NMOS open-drain outputs when the bus drive function is selected.

Figure 15.1 shows a block diagram of the I²C bus interface. Figure 15.2 shows an example of I/O pin connections to external circuits. Since I²C bus interface I/O pins are different in structure from normal port pins, they have different specifications for permissible applied voltages. For details, see section 25, Electrical Characteristics.

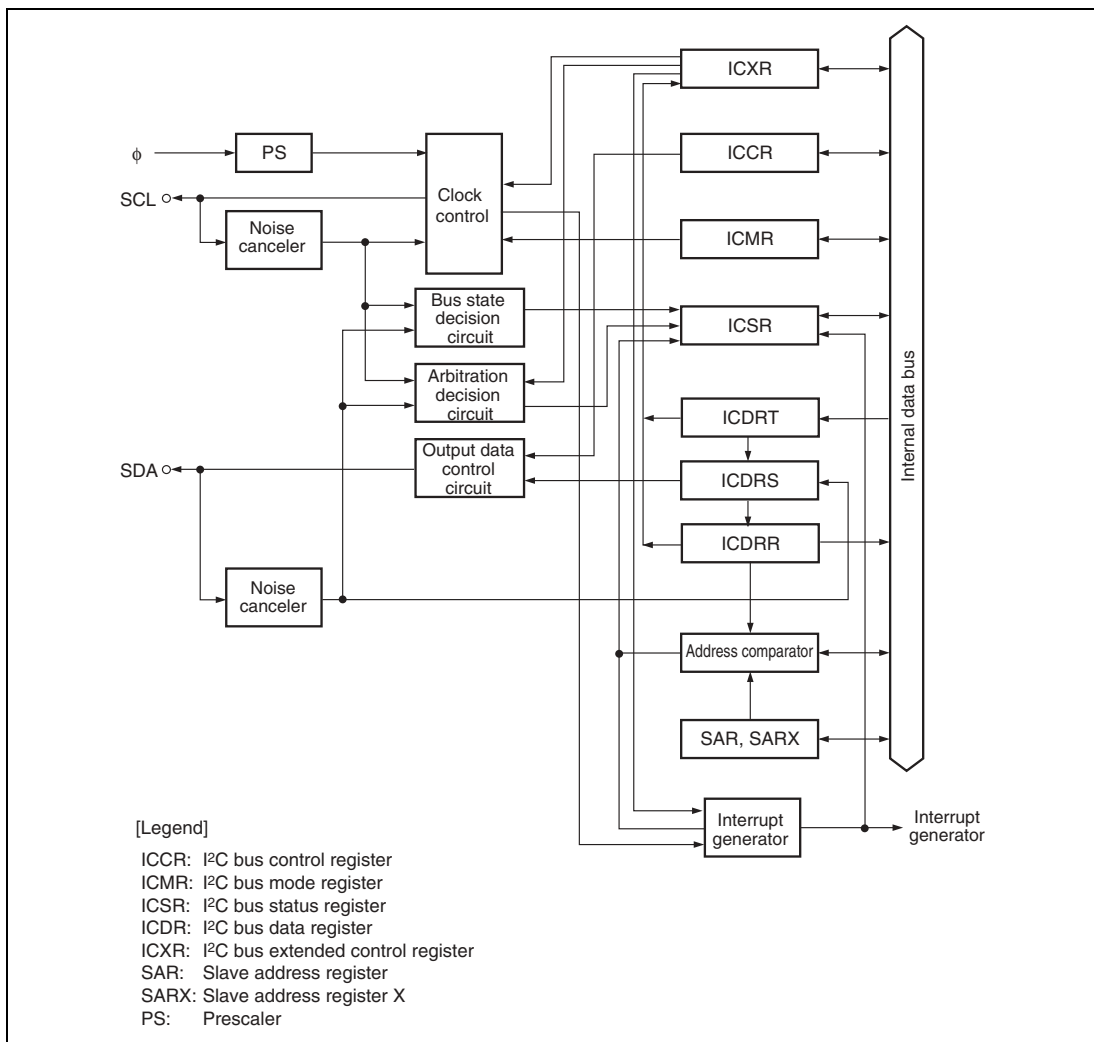

Figure 15.1 Block Diagram of I²C Bus Interface

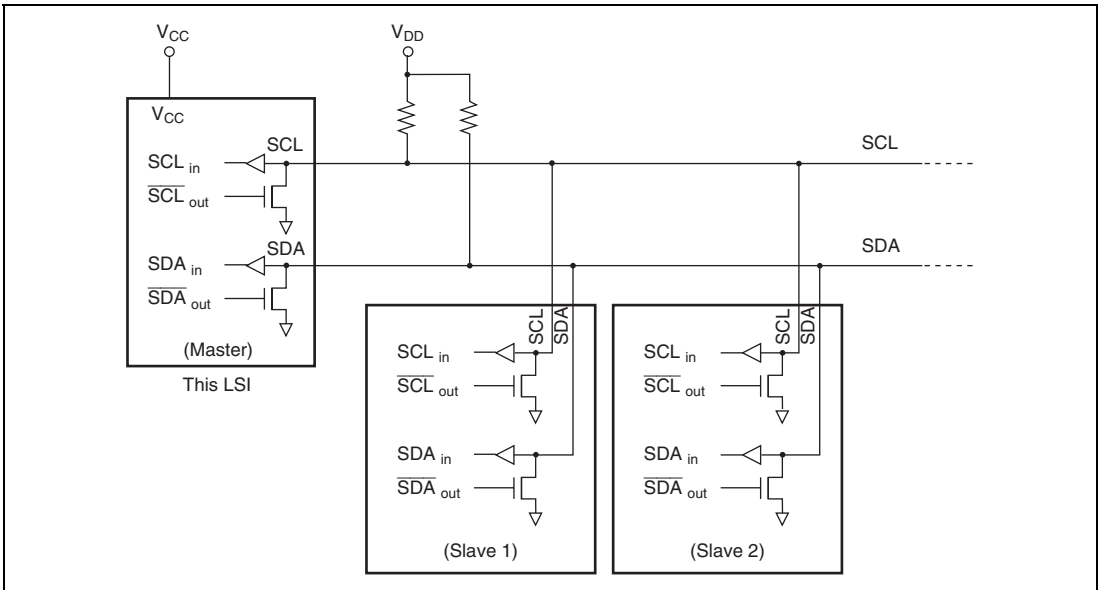

Figure 15.2 I²C Bus Interface Connections (Example: This LSI as Master)

15.2 Input/Output Pins

Table 15.1 summarizes the input/output pins used by the I²C bus interface.

Table 15.1 Pin Configuration

Channel	Symbol*	Input/Output	Function
0	SCL0	Input/Output	Clock input/output pin of channel IIC_0
	SDA0	Input/Output	Data input/output pin of channel IIC_0
1	SCL1	Input/Output	Clock input/output pin of channel IIC_1
	SDA1	Input/Output	Data input/output pin of channel IIC_1
2	SCL2	Input/Output	Clock input/output pin of channel IIC_2
	SDA2	Input/Output	Data input/output pin of channel IIC_2
3	SCL3	Input/Output	Clock input/output pin of channel IIC_3
	SDA3	Input/Output	Data input/output pin of channel IIC_3
4	SCL4	Input/Output	Clock input/output pin of channel IIC_4
	SDA4	Input/Output	Data input/output pin of channel IIC_4
5	SCL5	Input/Output	Clock input/output pin of channel IIC_5
	SDA5	Input/Output	Data input/output pin of channel IIC_5

Note: * In the text, the channel subscript is omitted, and only SCL and SDA are used.

15.3 Register Descriptions

The I²C bus interface has the following registers. Registers ICDR and SARX and registers ICMR and SAR are allocated to the same addresses. Accessible registers differ depending on the ICE bit in ICCR. When the ICE bit is cleared to 0, SAR and SARX can be accessed, and when the ICE bit is set to 1, ICMR and ICDR can be accessed. The IIC registers are allocated to the same address. Selecting register is carried out by means of the IICE bit in the serial timer control register (STCR).

- I²C bus data register (ICDR)
- Slave address register (SAR)
- Second slave address register (SARX)
- I²C bus mode register (ICMR)
- I²C bus transfer rate select register (IICX3)
- I²C bus control register (ICCR)
- I²C bus status register (ICSR)
- I²C bus extended control register (ICXR)
- I²C SMbus control register (ICSMBCR)

15.3.1 I²C Bus Data Register (ICDR)

ICDR is an 8-bit readable/writable register that is used as a transmit data register when transmitting and a receive data register when receiving. ICDR is divided internally into a shift register (ICDRS), receive buffer (ICDRR), and transmit buffer (ICDRT). Data transfers among the three registers are performed automatically in accordance with changes in the bus state, and they affect the status of internal flags such as ICDRE and ICDRF.

In master transmit mode with the I²C bus format, writing transmit data to ICDR should be performed after start condition detection. When the start condition is detected, previous write data is ignored. In slave transmit mode, writing should be performed after the slave addresses match and the TRS bit is automatically changed to 1.

If IIC is in transmit mode (TRS=1) and the next data is in ICDRT (the ICDRE flag is 0), data is transferred automatically from ICDRT to ICDRS, following transmission of one frame of data using ICDRS. When the ICDRE flag is 1 and the next transmit data writing is waited, data is transferred automatically from ICDRT to ICDRS by writing to ICDR. If IIC is in receive mode (TRS=0), no data is transferred from ICDRT to ICDRS. Note that data should not be written to ICDR in receive mode.

Reading receive data from ICDR is performed after data is transferred from ICDRS to ICDRR.

If IIC is in receive mode and no previous data remains in ICDRR (the ICDRF flag is 0), data is transferred automatically from ICDRS to ICDRR, following reception of one frame of data using ICDRS. If additional data is received while the ICDRF flag is 1, data is transferred automatically from ICDRS to ICDRR by reading from ICDR. In transmit mode, no data is transferred from ICDRS to ICDRR. Always set IIC to receive mode before reading from ICDR.

If the number of bits in a frame, excluding the acknowledge bit, is less than eight, transmit data and receive data are stored differently. Transmit data should be written justified toward the MSB side when MLS = 0 in ICMR, and toward the LSB side when MLS = 1. Receive data bits should be read from the LSB side when MLS = 0, and from the MSB side when MLS = 1.

ICDR can be written to and read from only when the ICE bit is set to 1 in ICCR. The initial value of ICDR is undefined.

15.3.2 Slave Address Register (SAR)

SAR sets the slave address and selects the communication format. When the LSI is in slave mode with the I²C bus format selected, if the FS bit is set to 0 and the upper 7 bits of SAR match the upper 7 bits of the first frame received after a start condition, the LSI operates as the slave device specified by the master device. SAR can be accessed only when the ICE bit in ICCR is cleared to 0.

Bit	Bit Name	Initial Value	R/W	Description
7	SVA6	All 0	R/W	Slave Address
6	SVA5			Set a slave address.
5	SVA4			
4	SVA3			
3	SVA2			
2	SVA1			
1	SVA0			
0	FS	0	R/W	
				Selects the communication format together with the FSX bit in SARX. Refer to table 15.2.
				This bit should be set to 0 when general call address recognition is performed.

15.3.3 Second Slave Address Register (SARX)

SARX sets the second slave address and selects the communication format. In slave mode, transmit/receive operations by the DTC are possible when the received address matches the second slave address. When the LSI is in slave mode with the I²C bus format selected, if the FSX bit is set to 0 and the upper 7 bits of SARX match the upper 7 bits of the first frame received after a start condition, the LSI operates as the slave device specified by the master device. SARX can be accessed only when the ICE bit in ICCR is cleared to 0.

Bit	Bit Name	Initial Value	R/W	Description
7	SVAX6	All 0	R/W	Second Slave Address
6	SVAX5			Set the second slave address.
5	SVAX4			
4	SVAX3			
3	SVAX2			
2	SVAX1			
1	SVAX0			
0	FSX	1	R/W	Format Select X Selects the communication format together with the FS bit in SAR. Refer to table 15.2.

Table 15.2 Transfer Format

SAR FS	SARX FSX	Operating Mode
0	0	I ² C bus format <ul style="list-style-type: none"> SAR and SARX slave addresses recognized General call address recognized
	1	I ² C bus format <ul style="list-style-type: none"> SAR slave address recognized SARX slave address ignored General call address recognized
1	0	I ² C bus format <ul style="list-style-type: none"> SAR slave address ignored SARX slave address recognized General call address ignored
	1	Clocked synchronous serial format <ul style="list-style-type: none"> SAR and SARX slave addresses ignored General call address ignored

- I²C bus format: addressing format with acknowledge bit
- Clocked synchronous serial format: non-addressing format without acknowledge bit, for master mode only

15.3.4 I²C Bus Mode Register (ICMR)

ICMR sets the communication format and transfer rate. It can only be accessed when the ICE bit in ICCR is set to 1.

Bit	Bit Name	Initial Value	R/W	Description
7	MLS	0	R/W	MSB-First/LSB-First Select 0: MSB-first 1: LSB-first Set this bit to 0 when the I ² C bus format is used.
6	WAIT	0	R/W	Wait Insertion Bit This bit is valid only in master mode with the I ² C bus format. 0: Data and the acknowledge bit are transferred consecutively with no wait inserted. 1: After the fall of the clock for the final data bit (8th clock), the IRIC flag is set to 1 in ICCR, and a wait state begins (with SCL at the low level). When the IRIC flag is cleared to 0 in ICCR, the wait ends and the acknowledge bit is transferred. For details, refer to section 15.4.7, IRC Setting Timing and SCL Control.
5	CKS2	All 0	R/W	Transfer Clock Select
4	CKS1			These bits are used only in master mode. These bits select the required transfer rate, together with the IICX5 (channel 5), IICX4 (channel 4), and IICX3 (channel 3) bits in IICX3, and the IICX2 (channel 2), IICX1 (channel 1), and IICX0 (channel 0) bits in STCR. Refer to table 15.3.
3	CKS0			

Bit	Bit Name	Initial Value	R/W	Description
2	BC2	All 0	R/W	Bit Counter
1	BC1			These bits specify the number of bits to be transferred next. Bit BC2 to BC0 settings should be made during an interval between transfer frames. If bits BC2 to BC0 are set to a value other than B'000, the setting should be made while the SCL line is low.
0	BC0			
				The bit counter is initialized to B'000 when a start condition is detected. The value returns to B'000 at the end of a data transfer.
				I ² C Bus Format Clocked Synchronous Serial Mode
				B'000: 9 bits B'000: 8 bits
				B'001: 2 bits B'001: 1 bits
				B'010: 3 bits B'010: 2 bits
				B'011: 4 bits B'011: 3 bits
				B'100: 5 bits B'100: 4 bits
				B'101: 6 bits B'101: 5 bits
				B'110: 7 bits B'110: 6 bits
				B'111: 8 bits B'111: 7 bits

15.3.5 I²C Bus Transfer Rate Select Register (IICX3)

IICX3 selects the IIC transfer rate clock and sets the transfer rate of IIC channels 3 to 5.

Bit	Bit Name	Initial Value	R/W	Description
7 to 4	—	—	—	Reserved These bits cannot be modified.
3	TCSS	0	R/W	Transfer Rate Clock Source Select This bit selects a clock rate to be applied to the I ² C bus transfer rate. 0: $\phi/2$ 1: $\phi/4$
2	IICX5	All 0	R/W	IIC Transfer Rate Select
1	IICX4			These bits are used to control IIC operation. These bits select the transfer rate in master mode, together with the CKS2 to CKS0 bits in ICMR. For the transfer rate, see table 15.3. IICX5, IICX4, and IICX3 control IIC_5, IIC_4, and IIC_3, respectively
0	IICX3			

Table 15.3 I²C bus Transfer Rate (1)

- TCSS = 0

IICX3	ICMR			Clock	Transfer Rate (MHz)							
	Bit 5	Bit 4	Bit 3		$\phi = 5$ MHz	$\phi = 8$ MHz	$\phi = 10$ MHz	$\phi = 16$ MHz	$\phi = 20$ MHz	$\phi = 25$ MHz	$\phi = 33$ MHz	
0	0	0	0	$\phi/28$	178.6	285.7	357.1	571.4* ¹	714.3* ¹	892.9* ¹	1178.6* ¹	
			1	$\phi/40$	125.0	200.0	250.0	400.0	500.0* ¹	625.0* ¹	825.0* ¹	
		1	0	$\phi/48$	104.2	166.7	208.3	333.3	416.7* ¹	520.8* ¹	687.5* ¹	
			1	$\phi/64$	78.1	125.0	156.3	250.0	312.5	390.6	515.6* ¹	
	1	0	0	$\phi/80$	62.5	100.0	125.0	200.0	250.0	312.5	412.5* ¹	
			1	$\phi/100$	50.0	80.0	100.0	160.0	200.0	250.0	330.0* ²	
		1	0	$\phi/112$	44.6	71.4	89.3	142.9	178.6	223.2	294.6* ²	
			1	$\phi/128$	39.1	62.5	78.1	125.0	156.3	195.3	257.8* ²	
	1	0	0	0	$\phi/56$	89.3	142.9	178.6	285.7	357.1	446.4* ¹	589.3* ¹
				1	$\phi/80$	62.5	100.0	125.0	200.0	250.0	312.5	412.5* ¹
			1	0	$\phi/96$	52.1	83.3	104.2	166.7	208.3	260.4	343.8
				1	$\phi/128$	39.1	62.5	78.1	125.0	156.3	195.3	257.8
1		0	0	$\phi/160$	31.3	50.0	62.5	100.0	125.0	156.3	206.3	
			1	$\phi/200$	25.0	40.0	50.0	80.0	100.0	125.0	165.0	
		1	0	$\phi/224$	22.3	35.7	44.6	71.4	89.3	111.6	147.3	
			1	$\phi/256$	19.5	31.3	39.1	62.5	78.1	97.7	128.9	

- Notes: 1. The correct operation cannot be guaranteed since the value is outside the I²C bus interface specifications (high-speed mode: max. 400 kHz)
2. When operate IIC in this setting, see 5 in section 15.6, Usage Notes.
(n = 0 to 5)

Table 15.3 I²C bus Transfer Rate (2)

- TCSS = 1

IICX3	ICMR			Clock	Transfer Rate (MHz)							
	Bit 5	Bit 4	Bit 3		$\phi = 5$ MHz	$\phi = 8$ MHz	$\phi = 10$ MHz	$\phi = 16$ MHz	$\phi = 20$ MHz	$\phi = 25$ MHz	$\phi = 33$ MHz	
0	0	0	0	$\phi/56$	89.3	142.9	178.6	285.7	357.1	446.4*	589.3*	
			1	$\phi/80$	62.5	100.0	125.0	200.0	250.0	312.5	412.5*	
		1	0	$\phi/96$	52.1	83.3	104.2	166.7	208.3	260.4	343.8	
			1	$\phi/128$	39.1	62.5	78.1	125.0	156.3	195.3	257.8	
		1	0	0	$\phi/160$	31.3	50.0	62.5	100.0	125.0	156.3	206.3
			1	$\phi/200$	25.0	40.0	50.0	80.0	100.0	125.0	165.0	
	1	0	0	$\phi/224$	22.3	35.7	44.6	71.4	89.3	111.6	147.3	
			1	$\phi/256$	19.5	31.3	39.1	62.5	78.1	97.7	128.9	
		1	0	0	$\phi/112$	44.6	71.4	89.3	142.9	178.6	223.2	294.6
				1	$\phi/160$	31.3	50.0	62.5	100.0	125.0	156.3	206.3
			1	0	$\phi/190$	26.0	41.7	52.1	83.3	104.2	130.2	171.9
				1	$\phi/256$	19.5	31.3	39.1	62.5	78.1	97.7	128.9
1	0	0	$\phi/320$	15.6	25.0	31.3	50.0	62.5	78.1	103.1		
		1	$\phi/400$	12.5	20.0	25.0	40.0	50.0	62.5	82.5		
	1	0	$\phi/448$	11.2	17.9	22.3	35.7	44.6	55.8	73.7		
		1	$\phi/512$	9.8	15.6	19.5	31.3	39.1	48.8	64.5		

Note: * The correct operation cannot be guaranteed since the value is outside the I²C bus interface specifications (high-speed mode: max. 400 kHz)
(n = 0 to 5)

15.3.6 I²C Bus Control Register (ICCR)

ICCR controls the I²C bus interface and performs interrupt flag confirmation.

Bit	Bit Name	Initial Value	R/W	Description
7	ICE	0	R/W	<p>I²C Bus Interface Enable</p> <p>0: I²C bus interface modules are stopped and I²C bus interface module internal state is initialized. SAR and SARX can be accessed.</p> <p>1: I²C bus interface modules can perform transfer and reception, they are connected to the SCL and SDA pins, and the I²C bus can be driven. ICMR and ICDR can be accessed.</p>
6	IEIC	0	R/W	<p>I²C Bus Interface Interrupt Enable</p> <p>0: Disables interrupts from the I²C bus interface to the CPU</p> <p>1: Enables interrupts from the I²C bus interface to the CPU.</p>
5	MST	0	R/W	Master/Slave Select
4	TRS	0	R/W	<p>Transmit/Receive Select</p> <p>00: Slave receive mode</p> <p>01: Slave transmit mode</p> <p>10: Master receive mode</p> <p>11: Master transmit mode</p> <p>Both these bits will be cleared by hardware when they lose in a bus contention in master mode of the I²C bus format. In slave receive mode with I²C bus format, the R/W bit in the first frame immediately after the start condition automatically sets these bits in receive mode or transmit mode by hardware.</p> <p>Modification of the TRS bit during transfer is deferred until transfer is completed, and the changeover is made after completion of the transfer.</p>

Bit	Bit Name	Initial Value	R/W	Description
5	MST	0	R/W	[MST clearing conditions]
4	TRS	0	R/W	<p>(1) When 0 is written by software</p> <p>(2) When lost in bus contention in I²C bus format master mode</p> <p>[MST setting conditions]</p> <p>(1) When 1 is written by software (for MST clearing condition 1)</p> <p>(2) When 1 is written in MST after reading MST = 0 (for MST clearing condition 2)</p> <p>[TRS clearing conditions]</p> <p>(1) When 0 is written by software (except for TRS setting condition 3)</p> <p>(2) When 0 is written in TRS after reading TRS = 1 (for TRS setting condition 3)</p> <p>(3) When lost in bus contention in I²C bus format master mode</p> <p>[TRS setting conditions]</p> <p>(1) When 1 is written by software (except for TRS clearing condition 3)</p> <p>(2) When 1 is written in TRS after reading TRS = 0 (for TRS clearing condition 3)</p> <p>(3) When 1 is received as the R/W bit after the first frame address matching in I²C bus format slave mode</p>
3	ACKE	0	R/W	<p>Acknowledge Bit Decision Selection</p> <p>0: The value of the acknowledge bit is ignored, and continuous transfer is performed. The value of the received acknowledge bit is not indicated by the ACKB bit in ICSR, which is always 0.</p> <p>1: If the acknowledge bit is 1, continuous transfer is halted.</p> <p>Depending on the receiving device, the acknowledge bit may be significant, in indicating completion of processing of the received data, for instance, or may be fixed at 1 and have no significance.</p>

Bit	Bit Name	Initial Value	R/W	Description
2	BBSY	0	R/W* ³	Bus Busy
0	SCP	1	W	Start Condition/Stop Condition Prohibit

In master mode

- Writing 0 in BBSY and 0 in SCP: A stop condition is issued
- Writing 1 in BBSY and 0 in SCP: A start condition and a restart condition are issued

In slave mode

- Writing to the BBSY flag is disabled.

[BBSY setting condition]

- When the SDA level changes from high to low under the condition of SCL = high, assuming that the start condition has been issued.

[BBSY clearing conditions]

- When the SDA level changes from low to high under the condition of SCL = high, assuming that the stop condition has been issued.

To issue a start/stop condition, use the MOV instruction.

The I²C bus interface must be set in master transmit mode before the issue of a start condition. Set MST to 1 and TRS to 1 before writing 1 in BBSY and 0 in SCP.

The BBSY flag can be read to check whether the I²C bus (SCL, SDA) is busy or free.

Bit	Bit Name	Initial Value	R/W	Description
1	IRIC	0	R/(W)* ¹	<p>I²C Bus Interface Interrupt Request Flag</p> <p>Indicates that the I²C bus interface has issued an interrupt request to the CPU.</p> <p>IRIC is set at different times depending on the FS bit in SAR and the WAIT bit in ICMR. See section 15.4.7, IRIC Setting Timing and SCL Control. The conditions under which IRIC is set also differ depending on the setting of the ACKE bit in ICCR.</p> <p>[Setting conditions]</p> <p>I²C bus format master mode:</p> <ul style="list-style-type: none"> • When a start condition is detected in the bus line state after a start condition is issued (when the ICDRE flag is set to 1 because of first frame transmission) • When a wait is inserted between the data and acknowledge bit when the WAIT bit is 1 (fall of the 8th transmit/receive clock) • At the end of data transfer (rise of the 9th transmit/receive clock) • When a slave address is received after bus mastership is lost • If 1 is received as the acknowledge bit (when the ACKB bit in ICSR is set to 1) when the ACKE bit is 1 • When the AL flag is set to 1 after bus mastership is lost while the ALIE bit is 1 <p>I²C bus format slave mode:</p> <ul style="list-style-type: none"> • When the slave address (SVA or SVAX) matches (when the AAS or AASX flag in ICSR is set to 1) and at the end of data transfer up to the subsequent retransmission start condition or stop condition detection (rise of the 9th clock) • When the general call address is detected (when the 0 is received for R/W bit, and ADZ flag in ICSR is set to 1) and at the end of data reception up to the subsequent retransmission start condition or stop condition detection (rise of the 9th receive clock) • When 1 is received as an acknowledge bit while the ACKE bit is 1 (when the ACKB bit is set to 1) • When a stop condition is detected while the STOPIM bit is 0 (when the STOP or ESTP flag in ICSR is set to 1)

Bit	Bit Name	Initial Value	R/W	Description
1	IRIC	0	R/(W)* ¹	<p>At the end of data transfer in clock synchronous serial format (rise of the 8th transmit/receive clock)</p> <p>When a start condition is detected with serial format selected</p> <p>When a condition occurs in which the ICDRE or ICDRF flag is set to 1.</p> <ul style="list-style-type: none"> • When a start condition is detected in transmit mode (when a start condition is detected and the ICDRE flag is set to 1) • When transmitting the data in the ICDR register buffer (when data is transferred from ICDRT to ICDRS in transmit mode and the ICDRE flag is set to 1, or data is transferred from ICDRS to ICDRR in receive mode and the ICDRF flag is set to 1.) <p>[Clearing conditions]</p> <ul style="list-style-type: none"> • When 0 is written in IRIC after reading IRIC = 1 • When ICDR is accessed by DTC *² (This may not be a clearing condition. For details, see the description of the DTC operation on the next page.)

-
- Notes: 1. Only 0 can be written to clear the flag to 0.
2. The DTC does not support IIC_4 and IIC_5.
3. If the BBSY bit is written to, the value of the flag is not changed.

When the DTC is used, IRIC is cleared automatically and transfer can be performed continuously without CPU intervention. The DTC does not support IIC_4 and IIC_5.

When, with the I²C bus format selected, IRIC is set to 1 and an interrupt is generated, other flags must be checked in order to identify the source that set IRIC to 1. Although each source has a corresponding flag, caution is needed at the end of a transfer.

When the ICDRE or ICDRF flag is set, the IRTR flag may or may not be set. The IRTR flag (the DTC start request flag) is not set at the end of a data transfer up to detection of a retransmission start condition or stop condition after a slave address (SVA) or general call address match in I²C bus format slave mode.

Even when the IRIC flag and IRTR flag are set, the ICDRE or ICDRF flag may not be set. The IRIC and IRTR flags are not cleared at the end of the specified number of transfers in continuous transfer using the DTC. The ICDRE or ICDRF flag is cleared, however, since the specified number of ICDR reads or writes have been completed.

Tables 15.4 and 15.5 show the relationship between the flags and the transfer states.

Table 15.4 Flags and Transfer States (Master Mode)

MST	TRS	BBSY	ESTP	STOP	IRTR	AASX	AL	AAS	ADZ	ACKB	ICDRF	ICDRE	State
1	1	0	0	0	0	0↓	0	0↓	0↓	0	—	0	Idle state (flag clearing required)
1	1	1↑	0	0	1↑	0	0	0	0	0	—	1↑	Start condition detected
1	—	1	0	0	—	0	0	0	0	—	—	—	Wait state
1	1	1	0	0	—	0	0	0	0	1↑	—	—	Transmission end (ACKE=1 and ACKB=1)
1	1	1	0	0	1↑	0	0	0	0	0	—	1↑	Transmission end with ICDRE=0
1	1	1	0	0	—	0	0	0	0	0	—	0↓	ICDR write with the above state
1	1	1	0	0	—	0	0	0	0	0	—	1	Transmission end with ICDRE=1
1	1	1	0	0	—	0	0	0	0	0	—	0↓	ICDR write with the above state or after start condition detected
1	1	1	0	0	1↑	0	0	0	0	0	—	1↑	Automatic data transfer from ICDRT to ICDRS with the above state
1	0	1	0	0	1↑	0	0	0	0	—	1↑	—	Reception end with ICDRF=0
1	0	1	0	0	—	0	0	0	0	—	0↓	—	ICDR read with the above state
1	0	1	0	0	—	0	0	0	0	—	1	—	Reception end with ICDRF=1
1	0	1	0	0	—	0	0	0	0	—	0↓	—	ICDR read with the above state
1	0	1	0	0	1↑	0	0	0	0	—	1↑	—	Automatic data transfer from ICDRS to ICDRR with the above state
0↓	0↓	1	0	0	—	0	1↑	0	0	—	—	—	Arbitration lost
1	—	0↓	0	0	—	0	0	0	0	—	—	0↓	Stop condition detected

[Legend]

0: 0-state retained 1: 1-state retained —: Previous state retained

0↓: Cleared to 0 1↑: Set to 1

Table 15.5 Flags and Transfer States (Slave Mode)

MST	TRS	BBSY	ESTP	STOP	IRTR	AASX	AL	AAS	ADZ	ACKB	ICDRF	ICDRE	State
0	0	0	0	0	0	0	0	0	0	0	—	0	Idle state (flag clearing required)
0	0	1↑	0	0	0	0↓	0	0	0	0	—	1↑	Start condition detected
0	1↑/0 *1	1	0	0	0	0	—	1↑	0	0	1↑	1	SAR match in first frame (SARX≠SAR)
0	0	1	0	0	0	0	—	1↑	1↑	0	1↑	1	General call address match in first frame (SARX≠H'00)
0	1↑/0 *1	1	0	0	1↑	1↑	—	0	0	0	1↑	1	SAR match in first frame (SAR≠SARX)
0	1	1	0	0	—	—	—	—	0	1↑	—	—	Transmission end (ACKE=1 and ACKB=1)
0	1	1	0	0	1↑/0 *1	—	—	—	0	0	—	1↑	Transmission end with ICDRE=0
0	1	1	0	0	—	—	0↓	0↓	0	0	—	0↓	ICDR write with the above state
0	1	1	0	0	—	—	—	—	0	0	—	1	Transmission end with ICDRE=1
0	1	1	0	0	—	—	0↓	0↓	0	0	—	0↓	ICDR write with the above state
0	1	1	0	0	1↑/0 *2	—	0	0	0	0	—	1↑	Automatic data transfer from ICDRT to ICDRS with the above state
0	0	1	0	0	1↑/0 *2	—	—	—	—	—	1↑	—	Reception end with ICDRF=0
0	0	1	0	0	—	—	0↓	0↓	0↓	—	0↓	—	ICDR read with the above state

MST	TRS	BBSY	ESTP	STOP	IRTR	AASX	AL	AAS	ADZ	ACKB	ICDRF	ICDRE	State
0	0	1	0	0	—	—	—	—	—	—	1	—	Reception end with ICDRF=1
0	0	1	0	0	—	—	0↓	0↓	0↓	—	0↓	—	ICDR read with the above state
0	0	1	0	0	1↑/0 *2	—	0	0	0	—	1↑	—	Automatic data transfer from ICDRS to ICDRR with the above state
0	—	0↓	1↑/0 *3	0/1↑ *3	—	—	—	—	—	—	—	0↓	Stop condition detected

[Legend]

0: 0-state retained 1: 1-state retained —: Previous state retained

0↓: Cleared to 0 1↑: Set to 1

Notes: 1. Set to 1 when 1 is received as a $R\overline{W}$ bit following an address.

2. Set to 1 when the AASX bit is set to 1.

3. When ESTP=1, STOP is 0, or when STOP=1, ESTP is 0.

15.3.7 I²C Bus Status Register (ICSR)

ICSR consists of status flags. Also see tables 15.4 and 15.5.

Bit	Bit Name	Initial Value	R/W	Description
7	ESTP	0	R/(W)*	<p>Error Stop Condition Detection Flag</p> <p>This bit is valid in I²C bus format slave mode.</p> <p>[Setting condition]</p> <p>When a stop condition is detected during frame transfer.</p> <p>[Clearing conditions]</p> <ul style="list-style-type: none">• When 0 is written in ESTP after reading ESTP = 1• When the IRIC flag in ICCR is cleared to 0
6	STOP	0	R/(W)*	<p>Normal Stop Condition Detection Flag</p> <p>This bit is valid in I²C bus format slave mode.</p> <p>[Setting condition]</p> <p>When a stop condition is detected after frame transfer is completed.</p> <p>[Clearing conditions]</p> <ul style="list-style-type: none">• When 0 is written in STOP after reading STOP = 1• When the IRIC flag is cleared to 0
5	IRTR	0	R/(W)*	<p>I²C Bus Interface Continuous Transfer Interrupt Request Flag</p> <p>Indicates that the I²C bus interface has issued an interrupt request to the CPU, and the source is completion of reception/transmission of one frame in continuous transmission/reception for which DTC activation is possible. When the IRTR flag is set to 1, the IRIC flag is also set to 1 at the same time.</p> <p>[Setting conditions]</p> <p>I²C bus format slave mode:</p> <ul style="list-style-type: none">• When the ICDRE or ICDRF flag in ICDR is set to 1 when AASX = 1 <p>I²C bus format master mode or clocked synchronous serial format mode:</p> <ul style="list-style-type: none">• When the ICDRE or ICDRF flag is set to 1 <p>[Clearing conditions]</p> <ul style="list-style-type: none">• When 0 is written after reading IRTR = 1• When the IRIC flag is cleared to 0 while ICE is 1

Bit	Bit Name	Initial Value	R/W	Description
4	AASX	0	R/(W)*	<p>Second Slave Address Recognition Flag</p> <p>In I²C bus format slave receive mode, this flag is set to 1 if the first frame following a start condition matches bits SVAX6 to SVAX0 in SARX.</p> <p>[Setting condition]</p> <p>When the second slave address is detected in slave receive mode and FSX = 0 in SARX</p> <p>[Clearing conditions]</p> <ul style="list-style-type: none"> • When 0 is written in AASX after reading AASX = 1 • When a start condition is detected • In master mode
3	AL	0	R/(W)*	<p>Arbitration Lost Flag</p> <p>Indicates that arbitration was lost in master mode.</p> <p>[Setting conditions]</p> <p>When ALSL=0</p> <ul style="list-style-type: none"> • If the internal SDA and SDA pin disagree at the rise of SCL in master transmit mode • If the internal SCL line is high at the fall of SCL in master mode <p>When ALSL=1</p> <ul style="list-style-type: none"> • If the internal SDA and SDA pin disagree at the rise of SCL in master transmit mode • If the SDA pin is driven low by another device before the I²C bus interface drives the SDA pin low, after the start condition instruction was executed in master transmit mode <p>[Clearing conditions]</p> <ul style="list-style-type: none"> • When ICDR is written to (transmit mode) or read from (receive mode) • When 0 is written in AL after reading AL = 1

Bit	Bit Name	Initial Value	R/W	Description
2	AAS	0	R/(W)*	<p>Slave Address Recognition Flag</p> <p>In I²C bus format slave receive mode, this flag is set to 1 if the first frame following a start condition matches bits SVA6 to SVA0 in SAR, or if the general call address (H'00) is detected.</p> <p>[Setting condition]</p> <p>When the slave address or general call address (one frame including a R/W bit is H'00) is detected in slave receive mode and FS = 0 in SAR</p> <p>[Clearing conditions]</p> <ul style="list-style-type: none"> • When ICDR is written to (transmit mode) or read from (receive mode) • When 0 is written in AAS after reading AAS = 1 • In master mode
1	ADZ	0	R/(W)*	<p>General Call Address Recognition Flag</p> <p>In I²C bus format slave receive mode, this flag is set to 1 if the first frame following a start condition is the general call address (H'00).</p> <p>[Setting condition]</p> <p>When the general call address (one frame including a R/W bit is H'00) is detected in slave receive mode and FS = 0 or FSX = 0</p> <p>[Clearing conditions]</p> <ul style="list-style-type: none"> • When ICDR is written to (transmit mode) or read from (receive mode) • When 0 is written in ADZ after reading ADZ = 1 • In master mode <p>If a general call address is detected while FS=1 and FSX=0, the ADZ flag is set to 1; however, the general call address is not recognized (AAS flag is not set to 1).</p>

Bit	Bit Name	Initial Value	R/W	Description
0	ACKB	0	R/W	<p>Acknowledge Bit</p> <p>Stores acknowledge data.</p> <p>Transmit mode:</p> <p>[Setting condition]</p> <p>When 1 is received as the acknowledge bit when ACKE=1 in transmit mode</p> <p>[Clearing conditions]</p> <ul style="list-style-type: none"> When 0 is received as the acknowledge bit when ACKE=1 in transmit mode When 0 is written to the ACKE bit <p>Receive mode:</p> <p>0: Returns 0 as acknowledge data after data reception</p> <p>1: Returns 1 as acknowledge data after data reception</p> <p>When this bit is read, the value loaded from the bus line (returned by the receiving device) is read in transmission (when TRS = 1). In reception (when TRS = 0), the value set by internal software is read.</p> <p>When this bit is written, acknowledge data that is returned after receiving is rewritten regardless of the TRS value. If the ICSR register bit is written using bit-manipulation instructions, the acknowledge data should be re-set since the acknowledge data setting is rewritten by the ACKB bit reading value.</p> <p>Write the ACKE bit to 0 to clear the ACKB flag to 0, before transmission is ended and a stop condition is issued in master mode, or before transmission is ended and SDA is released to issue a stop condition by a master device.</p>

Note: * Only 0 can be written to clear the flag.

15.3.8 I²C Bus Extended Control Register (ICXR)

ICXR enables or disables the I²C bus interface interrupt generation and continuous receive operation, and indicates the status of receive/transmit operations.

Bit	Bit Name	Initial Value	R/W	Description
7	STOPIM	0	R/W	<p>Stop Condition Interrupt Source Mask</p> <p>Enables or disables the interrupt generation when the stop condition is detected in slave mode.</p> <p>0: Enables IRIC flag setting and interrupt generation when the stop condition is detected (STOP = 1 or ESTP = 1) in slave mode.</p> <p>1: Disables IRIC flag setting and interrupt generation when the stop condition is detected.</p>
6	HNDS	0	R/W	<p>Handshake Receive Operation Select</p> <p>Enables or disables continuous receive operation in receive mode.</p> <p>0: Enables continuous receive operation</p> <p>1: Disables continuous receive operation</p> <p>When the HNDS bit is cleared to 0, receive operation is performed continuously after data has been received successfully while ICDRF flag is 0.</p> <p>When the HNDS bit is set to 1, SCL is fixed to the low level after data has been received successfully while ICDRF flag is 0; thus disabling the next data to be transferred. The bus line is released and next receive operation is enabled by reading the receive data in ICDR.</p>

Bit	Bit Name	Initial Value	R/W	Description
5	ICDRF	0	R	<p>Receive Data Read Request Flag</p> <p>Indicates the ICDR (ICDRR) status in receive mode.</p> <p>0: Indicates that the data has been already read from ICDR (ICDRR) or ICDR is initialized.</p> <p>1: Indicates that data has been received successfully and transferred from ICDRS to ICDRR, and the data is ready to be read out.</p> <p>[Setting conditions]</p> <ul style="list-style-type: none"> When data is received successfully and transferred from ICDRS to ICDRR. <p>(1) When data is received successfully while ICDRF = 0 (at the rise of the 9th clock pulse).</p> <p>(2) When ICDR is read successfully in receive mode after data was received while ICDRF = 1.</p> <p>[Clearing conditions]</p> <ul style="list-style-type: none"> When ICDR (ICDRR) is read. When 0 is written to the ICE bit. <p>When ICDRF is set due to the condition (2) above, ICDRF is temporarily cleared to 0 when ICDR (ICDRR) is read; however, since data is transferred from ICDRS to ICDRR immediately, ICDRF is set to 1 again.</p> <p>Note that ICDR cannot be read successfully in transmit mode (TRS = 1) because data is not transferred from ICDRS to ICDRR. Be sure to read data from ICDR in receive mode (TRS = 0).</p>

Bit	Bit Name	Initial Value	R/W	Description
4	ICDRE	0	R	<p>Transmit Data Write Request Flag</p> <p>Indicates the ICDR (ICDRT) status in transmit mode.</p> <p>0: Indicates that the data has been already written to ICDR (ICDRT) or ICDR is initialized.</p> <p>1: Indicates that data has been transferred from ICDRT to ICDRS and is being transmitted, or the start condition has been detected or transmission has been complete, thus allowing the next data to be written to.</p> <p>[Setting conditions]</p> <ul style="list-style-type: none"> • When the start condition is detected from the bus line state in I²C bus format or serial format. • When data is transferred from ICDRT to ICDRS. <ol style="list-style-type: none"> 1. When data is transmitted completely while ICDRE = 0 (at the rise of the 9th clock pulse). 2. When data is written to ICDR completely in transmit mode after data was transmitted while ICDRE = 1. <p>[Clearing conditions]</p> <ul style="list-style-type: none"> • When data is written to ICDR (ICDRT). • When the stop condition is detected in I²C bus format or serial format. • When 0 is written to the ICE bit. <p>Note that if the ACKE bit is set to 1 in I²C bus format thus enabling acknowledge bit decision, ICDRE is not set when data is transmitted completely while the acknowledge bit is 1.</p> <p>When ICDRE is set due to the condition (2) above, ICDRE is temporarily cleared to 0 when data is written to ICDR (ICDRT); however, since data is transferred from ICDRT to ICDRS immediately, ICDRF is set to 1 again. Do not write data to ICDR when TRS = 0 because the ICDRE flag value is invalid during the time.</p>

Bit	Bit Name	Initial Value	R/W	Description
3	ALIE	0	R/W	<p>Arbitration Lost Interrupt Enable</p> <p>Enables or disables IRIC flag setting and interrupt request when arbitration is lost.</p> <p>0: Disables interrupt request when arbitration is lost.</p> <p>1: Enables interrupt request when arbitration is lost.</p>
2	ALSL	0	R/W	<p>Arbitration Lost Condition Select</p> <p>Selects the condition under which arbitration is lost.</p> <p>0: If the SDA pin state disagrees with the data that I²C bus interface outputs at the rise of SCL and the SCL pin is driven low by another device.</p> <p>1: If the SDA pin state disagrees with the data that I²C bus interface outputs at the rise of SCL and the SDA line is driven low by another device in idle state or after the start condition instruction was executed.</p>
1	FNC1	0	R/W	Function Bit
0	FNC0	0	R/W	<p>These bits cancel some restrictions on usage. For details, refer to section 15.6, Usage Notes.</p> <p>00: Restrictions on operation remaining in effect</p> <p>01: Setting prohibited</p> <p>10: Setting prohibited</p> <p>11: Restrictions on operation canceled</p>

15.3.9 I²C SMBus Control Register (ICSMBCR)

ICSMBCR is used to support the System Management Bus (SMBus) specifications. To support the SMBus specification, SDA output data hold time should be specified in the range of 300 ns to 1000 ns. Table 15.6 shows the relationship between the ICSMBCR setting and output data hold time.

When the SMBus is not supported, the initial value should not be changed. ICSMBCR is enabled to access when bit MSTP4 is cleared to 0.

Bit	Bit Name	Initial Value	R/W	Description
7	SMB5E	All 0	R/W	SMBus Enable
6	SMB4E			These bits enable/disable to support the SMBus, combining with bits FSEL1 and FSEL0. The SMB5E bit controls IIC_5, the SMB4E bit controls IIC_4, the SMB3E bit controls IIC_3, the SMB2E bit controls IIC_2, the SMB1E bit controls IIC_1, the SMB0E bit controls IIC_0. 0: Disables to support the SMBus 1: Enables to support the SMBus
5	SMB3E			
4	SMB2E			
3	SMB1E			
2	SMB0E			
1	FSEL1	0	R/W	
0	FSEL0	0	R/W	These bits must be specified to match the system clock frequency in order to support the SMBus. For details of the setting, see table 15.7.

Table 15.6 Output Data Hold Time

			Output Data Hold Time (ns)										
SMBnE	FSEL1	FSEL0	Min./	$\phi = 5$	$\phi = 6.6$	$\phi = 8$	$\phi = 10$	$\phi = 13.3$	$\phi = 16$	$\phi = 20$	$\phi = 25$	$\phi = 33$	
			Max.	MHz	MHz	MHz	MHz	MHz	MHz	MHz	MHz	MHz	MHz
0	—	—	Min.	400	303	250*	200*	150*	125*	100*	80*	61*	
			Max.	600	455	375	300	226*	188*	150*	120*	91*	
1	0	0	Min.	600	455	375	300	226*	188*	150*	120*	91*	
			Max.	1000*	758	625	500	376	313	250*	200*	152*	
	1	1	Min.	800	606	500	400	301	250*	200*	160*	121*	
			Max.	1400*	1061*	875	700	526	438	350	280*	212*	
	1	0	1	Min.	1200*	909	750	600	451	375	300	240*	182*
				Max.	2200*	1667*	1375*	1100*	827	688	550	440	333
	1	1	Min.	2000*	1515*	1250*	1000*	752	625	500	400	303	
			Max.	3800*	2879*	2375*	1900*	1429*	1188*	950	760	576	

Notes: n = 0 to 5

* Since the value is outside the SMBus specification, it should not be set.

Table 15.7 ISCMBCR Setting

System Clock	SMBnE	FSEL1	FSEL0
5 to 6.6 MHz	0	0	0
6.6 to 10 MHz	1	0	0
10 to 13.3 MHz	1	0	1
13.3 to 20 MHz	1	1	0
20 to 33 MHz	1	1	1

n = 0 to 5

15.4 Operation

15.4.1 I²C Bus Data Format

The I²C bus interface has an I²C bus format and a serial format.

The I²C bus formats are addressing formats with an acknowledge bit. These are shown in figures 15.3 (a) and (b). The first frame following a start condition always consists of 9 bits.

The serial format is a non-addressing format with no acknowledge bit. This is shown in figure 15.4.

Figure 15.5 shows the I²C bus timing.

The symbols used in figures 15.3 to 15.5 are explained in table 15.8.

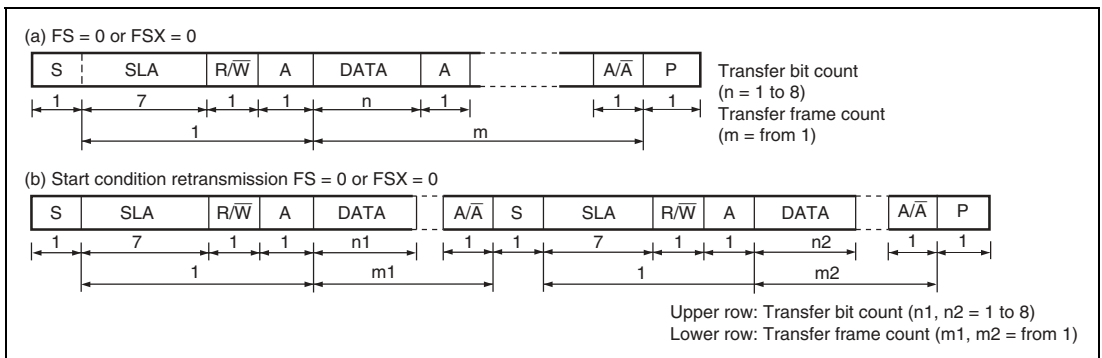

Figure 15.3 I²C Bus Data Formats (I²C Bus Formats)

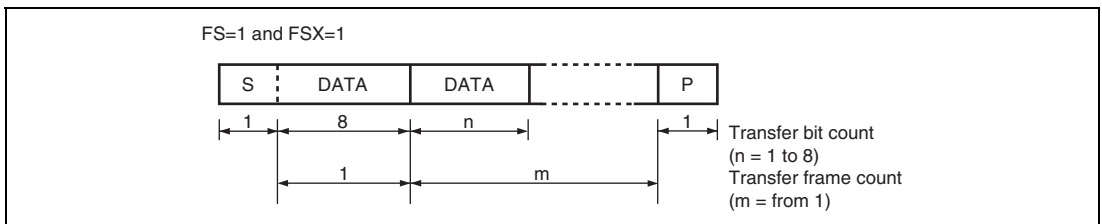

Figure 15.4 I²C Bus Data Formats (Serial Formats)

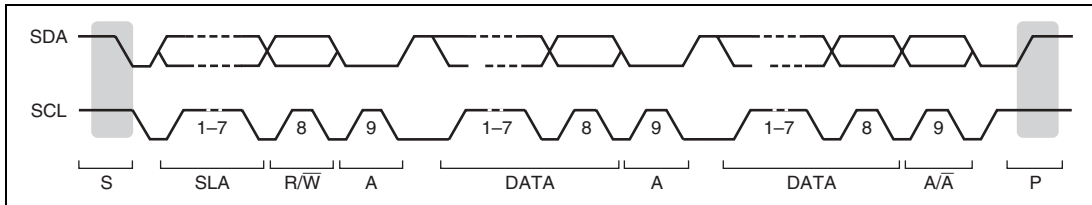

Figure 15.5 I²C Bus Timing

Table 15.8 I²C Bus Data Format Symbols

Symbol	Description
S	Start condition. The master device drives SDA from high to low while SCL is high
SLA	Slave address. The master device selects the slave device.
R/W	Indicates the direction of data transfer: from the slave device to the master device when R/W is 1, or from the master device to the slave device when R/W is 0
A	Acknowledge. The receiving device drives SDA low to acknowledge a transfer. (The slave device returns acknowledge in master transmit mode, and the master device returns acknowledge in master receive mode.)
DATA	Transferred data. The bit length of transferred data is set with the BC2 to BC0 bits in ICMR. The MSB first or LSB first is switched with the MLS bit in ICMR.
P	Stop condition. The master device drives SDA from low to high while SCL is high

15.4.2 Initialization

Initialize the IIC by the procedure shown in figure 15.6 before starting transmission/reception of data.

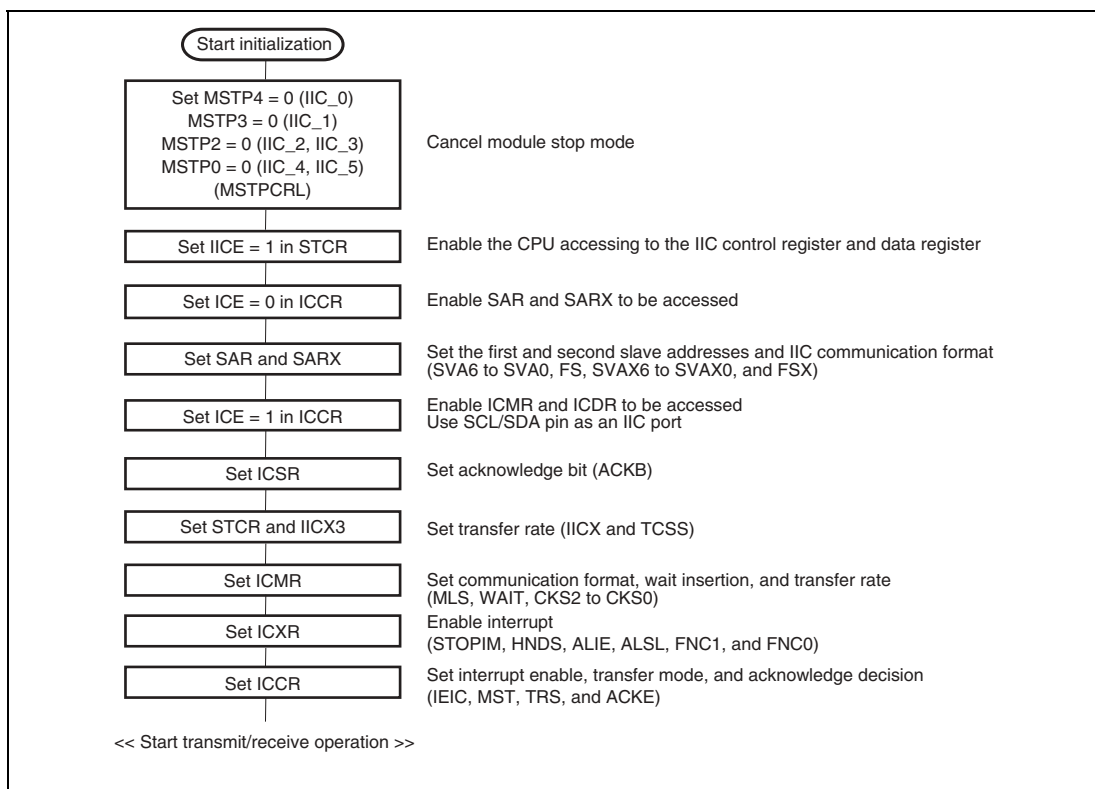

Figure 15.6 Sample Flowchart for IIC Initialization

Note: Be sure to modify the ICMR register after transmit/receive operation has been completed. If the ICMR register is modified during transmit/receive operation, bit counter BC2 to BC0 will be modified erroneously, thus causing incorrect operation.

15.4.3 Master Transmit Operation

In I²C bus format master transmit mode, the master device outputs the transmit clock and transmit data, and the slave device returns an acknowledge signal.

Figure 15.7 shows the sample flowchart for the operations in master transmit mode.

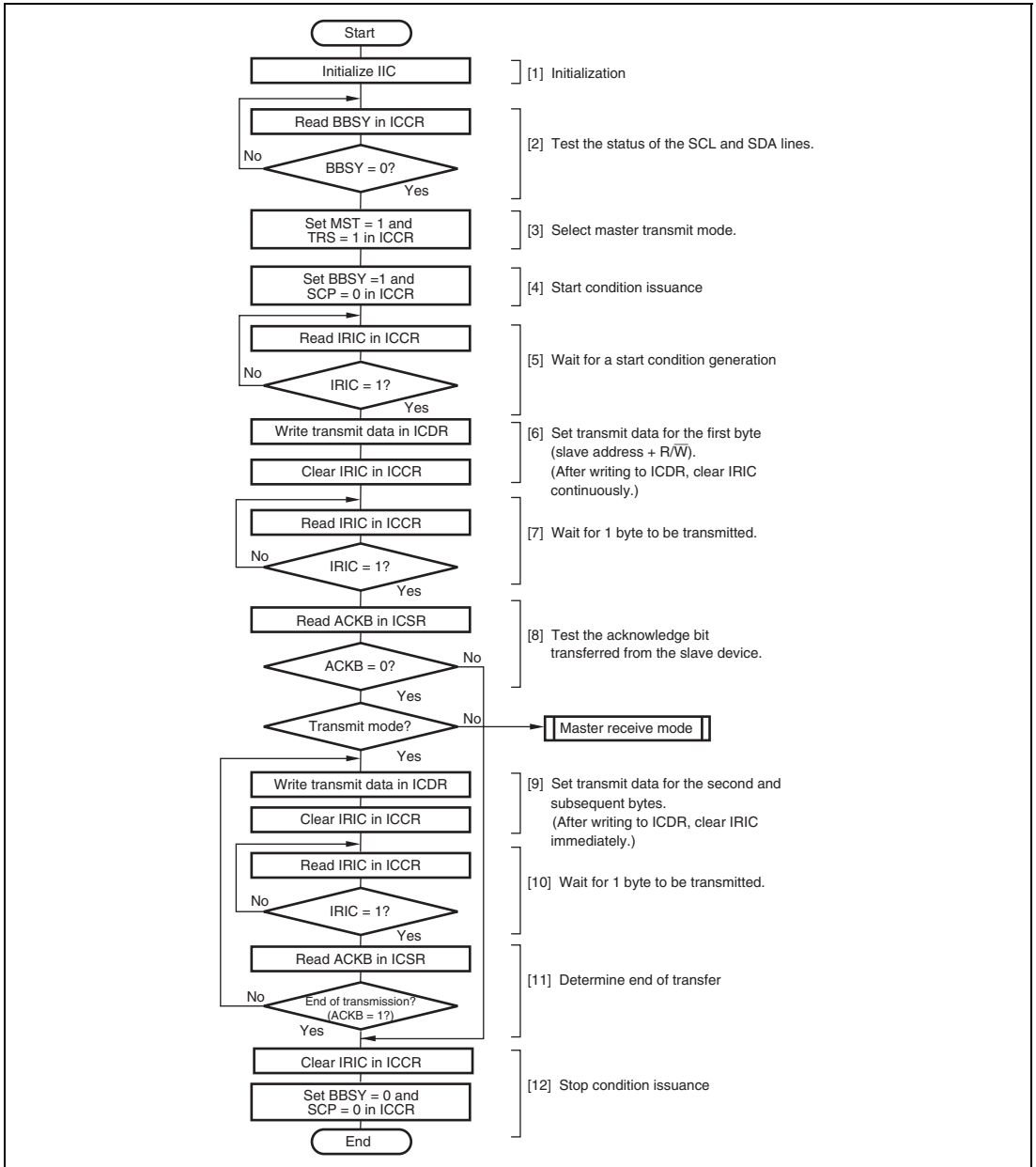

Figure 15.7 Sample Flowchart for Operations in Master Transmit Mode

The transmission procedure and operations by which data is sequentially transmitted in synchronization with ICDR (ICDRT) write operations, are described below.

- [1] Initialize the IIC as described in section 15.4.2, Initialization.
- [2] Read the BBSY flag in ICCR to confirm that the bus is free.
- [3] Set bits MST and TRS to 1 in ICCR to select master transmit mode.
- [4] Write 1 to BBSY and 0 to SCP in ICCR. This changes SDA from high to low when SCL is high, and generates the start condition.
- [5] Then the IRIC and IRTR flags are set to 1. If the IEIC bit in ICCR has been set to 1, an interrupt request is sent to the CPU.
- [6] Write the data (slave address + R/\overline{W}) to ICDR.

With the I²C bus format (when the FS bit in SAR or the FSX bit in SARX is 0), the first frame data following the start condition indicates the 7-bit slave address and transmit/receive direction (R/\overline{W}).

To determine the end of the transfer, the IRIC flag is cleared to 0. After writing to ICDR, clear IRIC continuously so no other interrupt handling routine is executed. If the time for transmission of one frame of data has passed before the IRIC clearing, the end of transmission cannot be determined. The master device sequentially sends the transmission clock and the data written to ICDR. The selected slave device (i.e. the slave device with the matching slave address) drives SDA low at the 9th transmit clock pulse and returns an acknowledge signal.
- [7] When one frame of data has been transmitted, the IRIC flag is set to 1 at the rise of the 9th transmit clock pulse. After one frame has been transmitted, SCL is automatically fixed low in synchronization with the internal clock until the next transmit data is written.
- [8] Read the ACKB bit in ICSR to confirm that ACKB is cleared to 0. When the slave device has not acknowledged (ACKB bit is 1), operate step [12] to end transmission, and retry the transmit operation.
- [9] Write the transmit data to ICDR.

As indicating the end of the transfer, the IRIC flag is cleared to 0. Perform the ICDR write and the IRIC flag clearing sequentially, just as in step [6]. Transmission of the next frame is performed in synchronization with the internal clock.
- [10] When one frame of data has been transmitted, the IRIC flag is set to 1 at the rise of the 9th transmit clock pulse. After one frame has been transmitted, SCL is automatically fixed low in synchronization with the internal clock until the next transmit data is written.
- [11] Read the ACKB bit in ICSR.

Confirm that the slave device has been acknowledged (ACKB bit is 0). When there is still data to be transmitted, go to step [9] to continue the next transmission operation. When the slave device has not acknowledged (ACKB bit is set to 1), operate step [12] to end transmission.
- [12] Clear the IRIC flag to 0.

Write 0 to ACKE in ICCR, to clear received ACKB contents to 0. Write 0 to BBSY and SCP in ICCR. This changes SDA from low to high when SCL is high, and generates the stop condition.

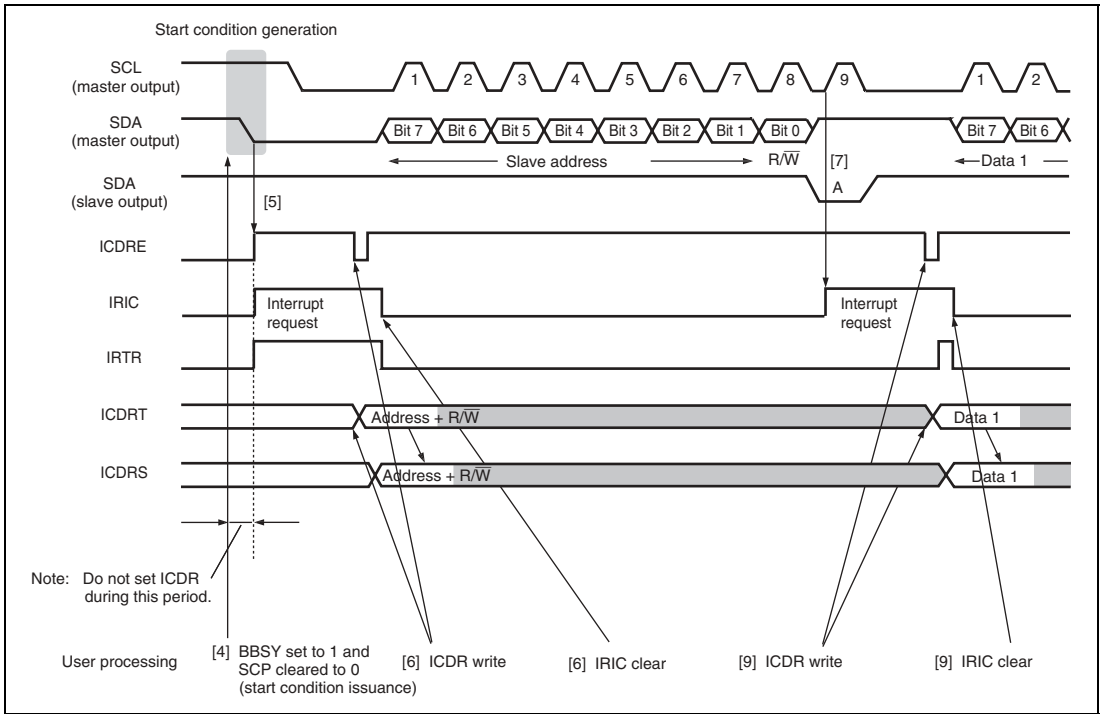

Figure 15.8 Operation Timing Example in Master Transmit Mode (MLS = WAIT = 0)

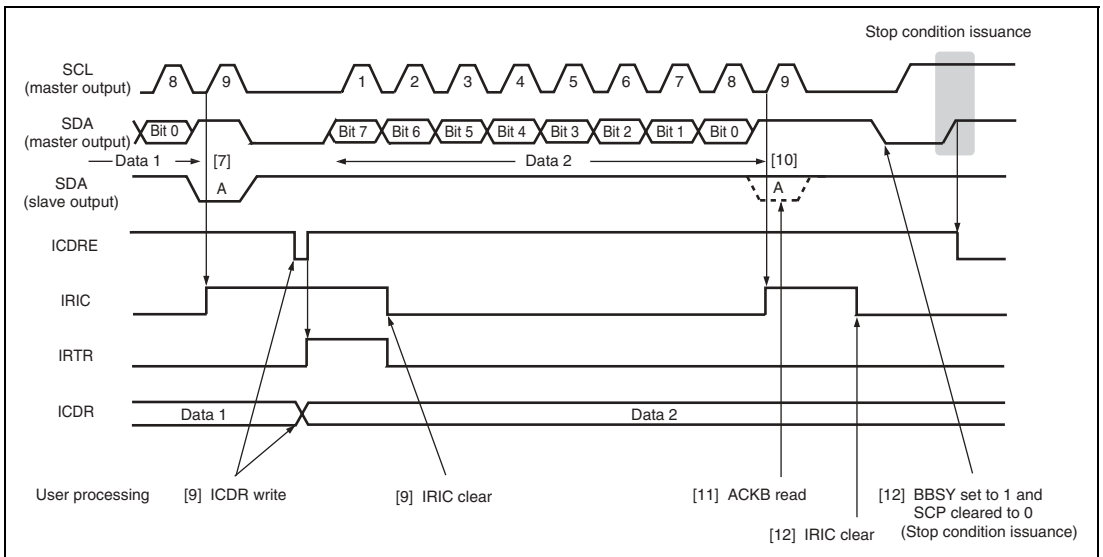

Figure 15.9 Stop Condition Issuance Operation Timing Example in Master Transmit Mode (MLS = WAIT = 0)

15.4.4 Master Receive Operation

In I²C bus format master receive mode, the master device outputs the receive clock, receives data, and returns an acknowledge signal. The slave device transmits data.

The master device transmits data containing the slave address and R/W (1: read) in the first frame following the start condition issuance in master transmit mode, selects the slave device, and then switches the mode for receive operation.

Receive Operation Using the HNDS Function (HNDS = 1):

Figure 15.10 shows the sample flowchart for the operations in master receive mode (HNDS = 1).

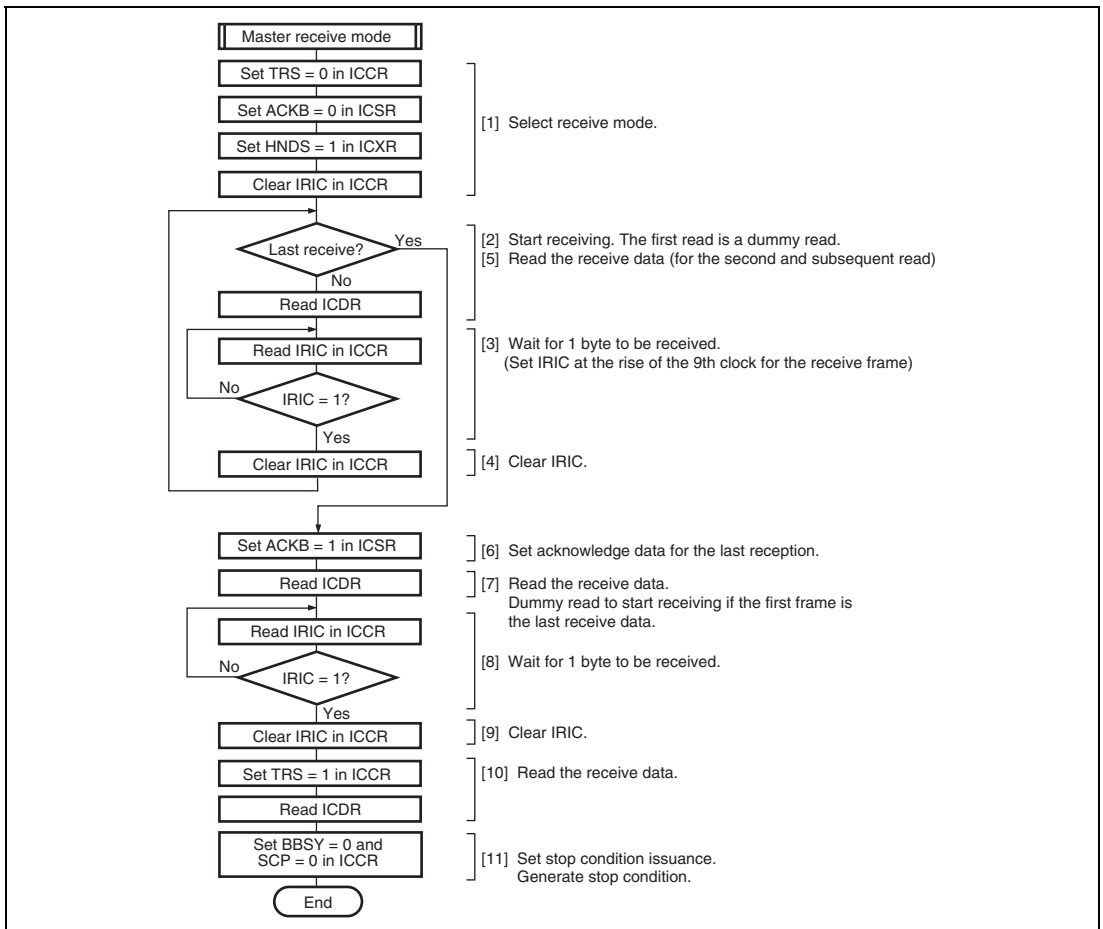

Figure 15.10 Sample Flowchart for Operations in Master Receive Mode (HNDS = 1)

The reception procedure and operations by which the data reception process is provided in 1-byte units with SCL fixed low at each data reception are described below.

- [1] Clear the TRS bit in ICCR to 0 to switch from transmit mode to receive mode.
Clear the ACKB bit in ICSR to 0 (acknowledge data setting).
Set the HNDS bit in ICXR to 1.
Clear the IRIC flag to 0 to determine the end of reception.
Go to step [6] to halt reception operation if the first frame is the last receive data.
- [2] When ICDR is read (dummy data read), reception is started, and the receive clock is output, and data received, in synchronization with the internal clock. (Data from the SDA pin is sequentially transferred to ICDRS in synchronization with the rise of the receive clock pulses.)
- [3] The master device drives SDA low to return the acknowledge data at the 9th receive clock pulse. The receive data is transferred to ICDRR from ICDRS at the rise of the 9th clock pulse, setting the ICDRF, IRIC, and IRTR flags to 1. If the IEIC bit has been set to 1, an interrupt request is sent to the CPU.
The master device drives SCL low from the fall of the 9th receive clock pulse to the ICDR data reading.
- [4] Clear the IRIC flag to determine the next interrupt.
Go to step [6] to halt reception operation if the next frame is the last receive data.
- [5] Read ICDR receive data. This clears the ICDRF flag to 0. The master device outputs the receive clock continuously to receive the next data.
Data can be received continuously by repeating steps [3] to [5].
- [6] Set the ACKB bit to 1 so as to return the acknowledge data for the last reception.
- [7] Read ICDR receive data. This clears the ICDRF flag to 0. The master device outputs the receive clock to receive data.
- [8] When one frame of data has been received, the ICDRF, IRIC, and IRTR flags are set to 1 at the rise of the 9th receive clock pulse.
- [9] Clear the IRIC flag to 0.
- [10] Read ICDR receive data after setting the TRS bit. This clears the ICDRF flag to 0.
- [11] Clear the BBSY bit and SCP bit to 0 in ICCR. This changes SDA from low to high when SCL is high, and generates the stop condition.

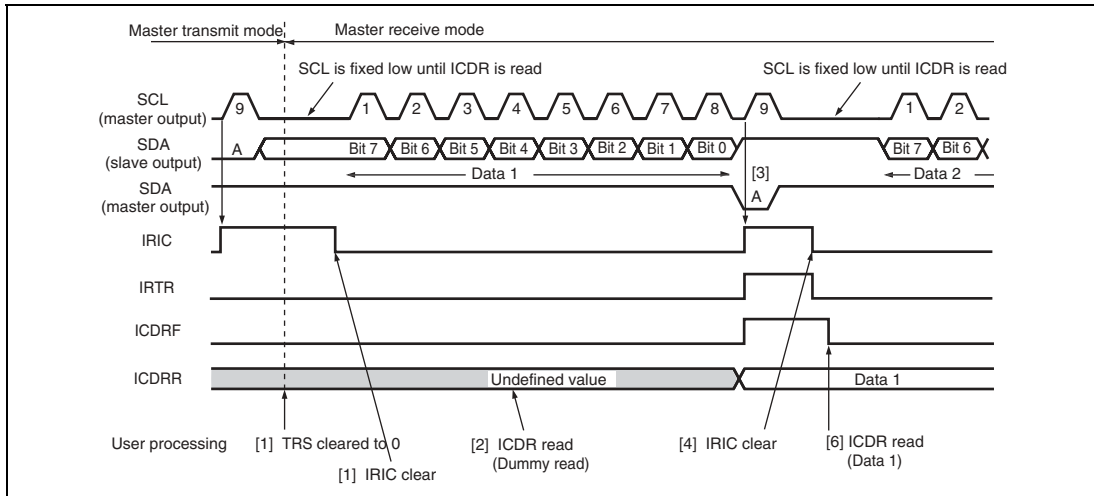

Figure 15.11 Master Receive Mode Operation Timing Example
(MLS = WAIT = 0, HNDS = 1)

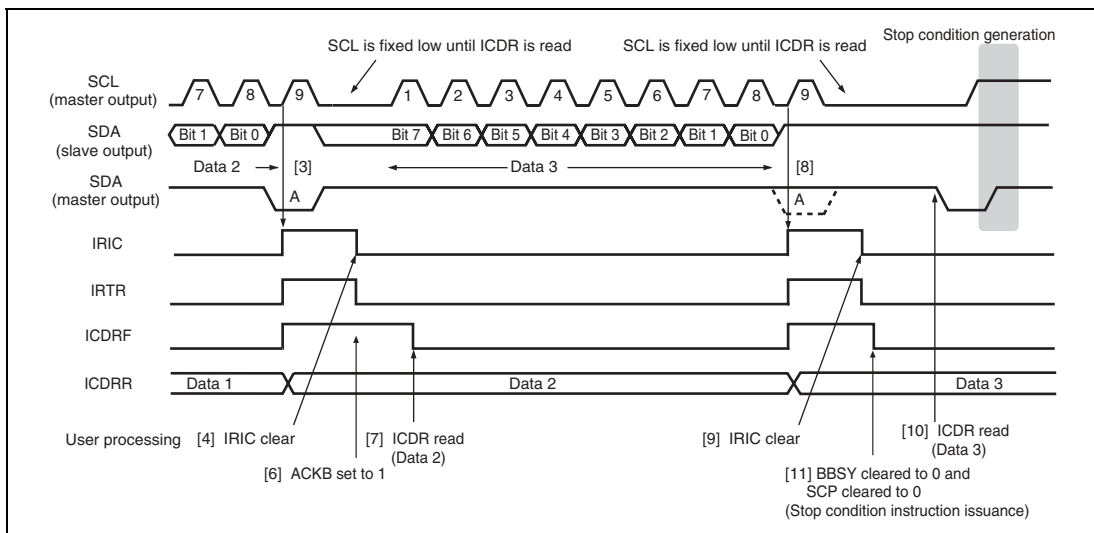

Figure 15.12 Stop Condition Issuance Timing Example in Master Receive Mode
(MLS = WAIT = 0, HNDS = 1)

Receive Operation Using the Wait Function:

Figures 15.13 and 15.14 show the sample flowcharts for the operations in master receive mode (WAIT = 1).

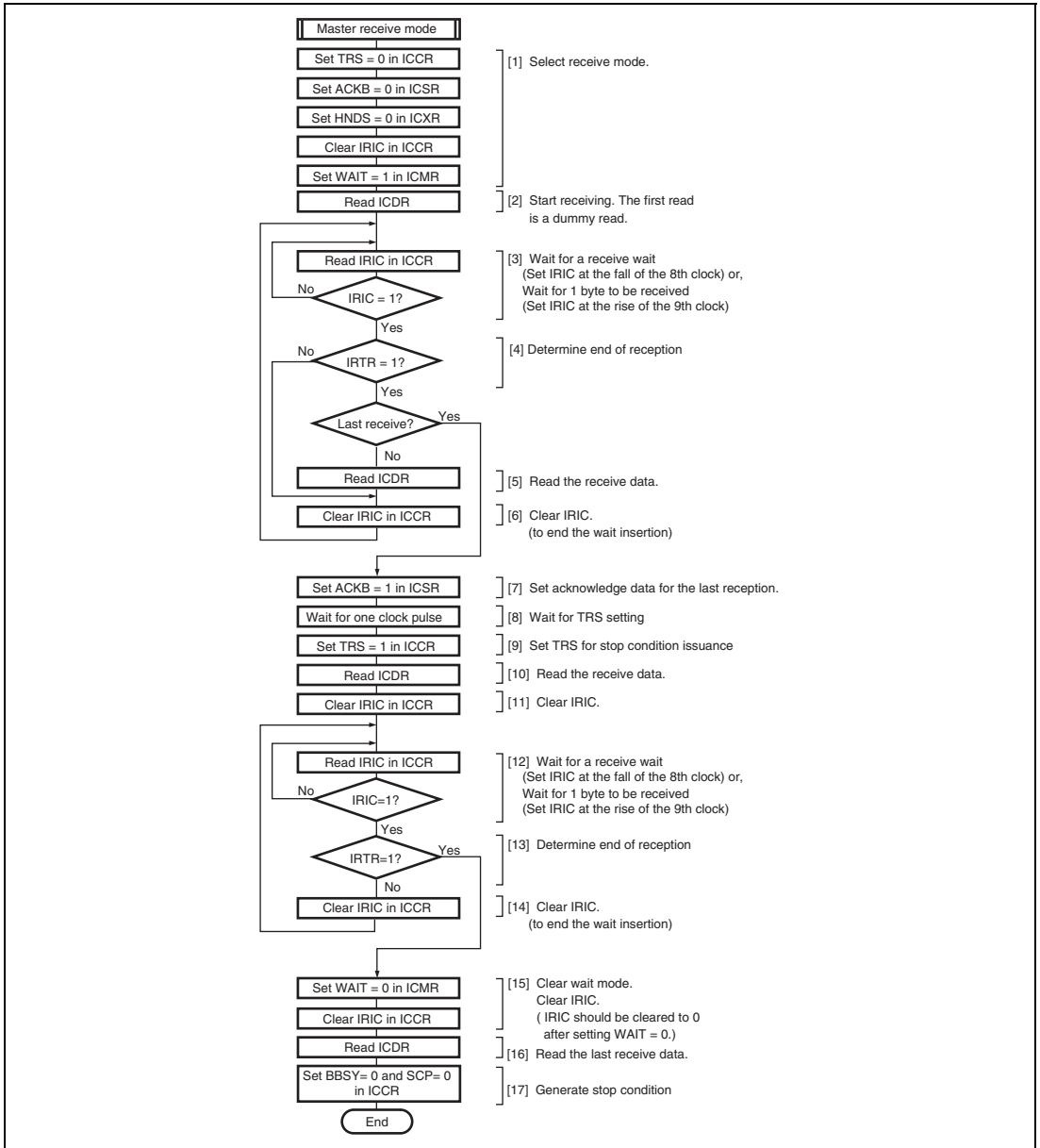

Figure 15.13 Sample Flowchart for Operations in Master Receive Mode (receiving multiple bytes) (WAIT = 1)

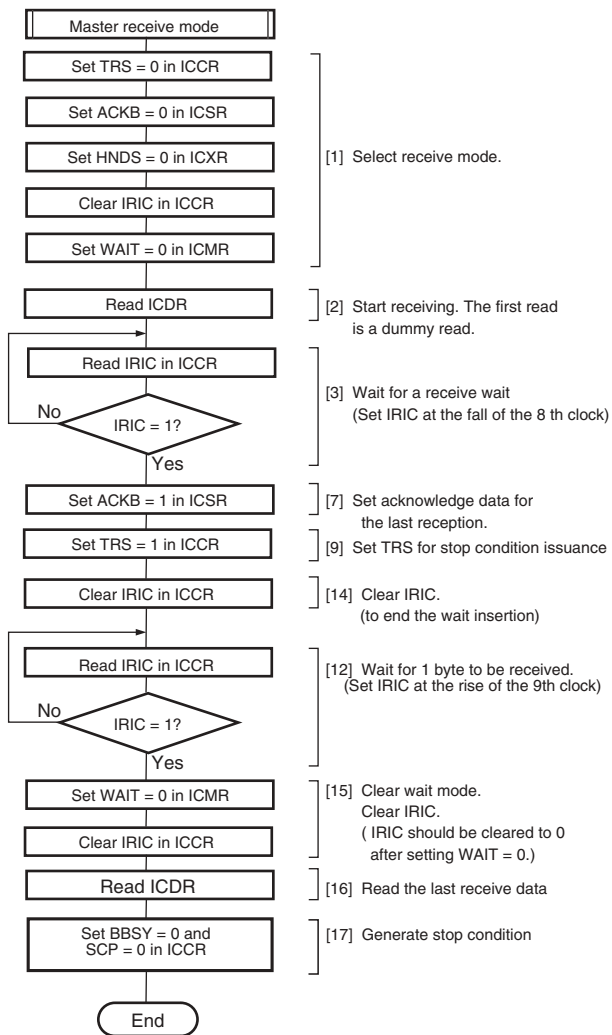

Figure 15.14 Sample Flowchart for Operations in Master Receive Mode (receiving a single byte) (WAIT = 1)

The reception procedure and operations using the wait function (WAIT bit), by which data is sequentially received in synchronization with ICDR (ICDRR) read operations, are described below.

The following describes the multiple-byte reception procedure. In single-byte reception, some steps of the following procedure are omitted. At this time, follow the procedure shown in figure 15.14

- [1] Clear the TRS bit in ICCR to 0 to switch from transmit mode to receive mode.
Clear the ACKB bit in ICSR to 0 to set the acknowledge data.
Clear the HNDS bit in ICXR to 0 to cancel the handshake function.
Clear the IRIC flag to 0, and then set the WAIT bit in ICMR to 1.
- [2] When ICDR is read (dummy data is read), reception is started, and the receive clock is output, and data received, in synchronization with the internal clock.
- [3] The IRIC flag is set to 1 in either of the following cases. If the IEIC bit in ICCR has been set to 1, an interrupt request is sent to the CPU.
- (1) At the fall of the 8th receive clock pulse for one frame
SCL is automatically fixed low in synchronization with the internal clock until the IRIC flag clearing.
 - (2) At the rise of the 9th receive clock pulse for one frame
The IRTR and ICDRF flags are set to 1, indicating that one frame of data has been received. The master device outputs the receive clock continuously to receive the next data.
- [4] Read the IRTR flag in ICSR.
If the IRTR flag is 0, execute step [6] to clear the IRIC flag to 0 to release the wait state.
If the IRTR flag is 1 and the next data is the last receive data, execute step [7] to halt reception.
- [5] If IRTR flag is 1, read ICDR receive data.
- [6] Clear the IRIC flag. When the flag is set as (1) in step [3], the master device outputs the 9th clock and drives SDA low at the 9th receive clock pulse to return an acknowledge signal.
- Data can be received continuously by repeating steps [3] to [6].
- [7] Set the ACKB bit in ICSR to 1 so as to return the acknowledge data for the last reception.
- [8] After the IRIC flag is set to 1, wait for at least one clock pulse until the rise of the first clock pulse for the next receive data.
- [9] Set the TRS bit in ICCR to 1 to switch from receive mode to transmit mode. The TRS bit value becomes valid when the rising edge of the next 9th clock pulse is input.
- [10] Read the ICDR receive data.
- [11] Clear the IRIC flag to 0.
- [12] The IRIC flag is set to 1 in either of the following cases.
- (1) At the fall of the 8th receive clock pulse for one frame
SCL is automatically fixed low in synchronization with the internal clock until the IRIC flag is cleared.
 - (2) At the rise of the 9th receive clock pulse for one frame
The IRTR and ICDRF flags are set to 1, indicating that one frame of data has been received.

- [13] Read the IRTR flag in ICSR.
If the IRTR flag is 0, execute step [14] to clear the IRIC flag to 0 to release the wait state.
If the IRTR flag is 1 and data reception is complete, execute step [15] to issue the stop condition.
- [14] If IRTR flag is 0, clear the IRIC flag to 0 to release the wait state.
Execute step [12] to read the IRIC flag to detect the end of reception.
- [15] Clear the WAIT bit in ICMR to cancel the wait mode.
Clearing of the IRIC flag should be done while WAIT = 0. (If the WAIT bit is cleared to 0 after clearing the IRIC flag and then an instruction to issue a stop condition is executed, the stop condition may not be issued correctly.)
- [16] Read the last ICDR receive data.
- [17] Clear the BBSY bit and SCP bit to 0 in ICCR. This changes SDA from low to high when SCL is high, and generates the stop condition.

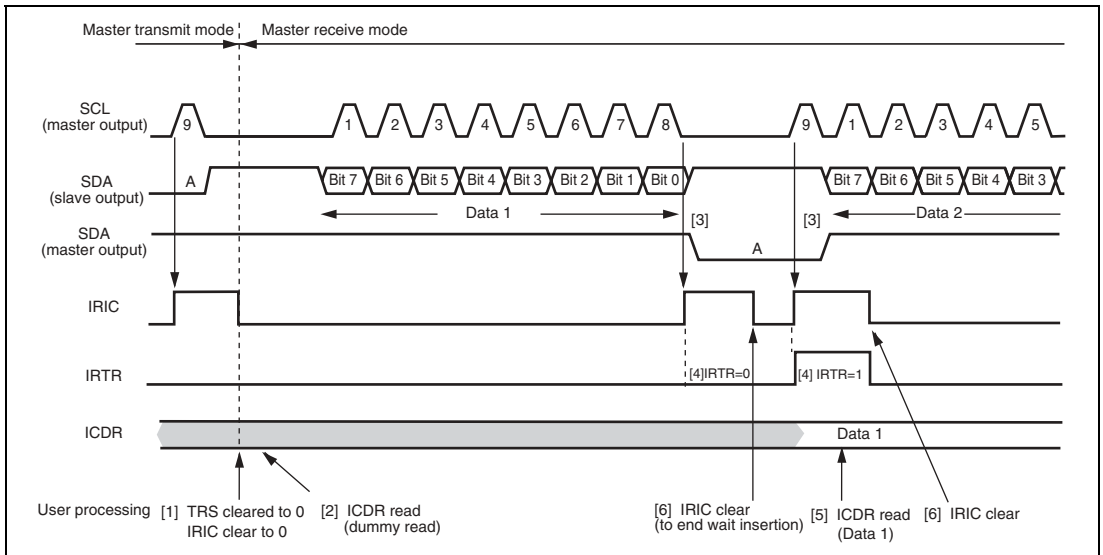

Figure 15.15 Master Receive Mode Operation Timing Example
(MLS = ACKB = 0, WAIT = 1)

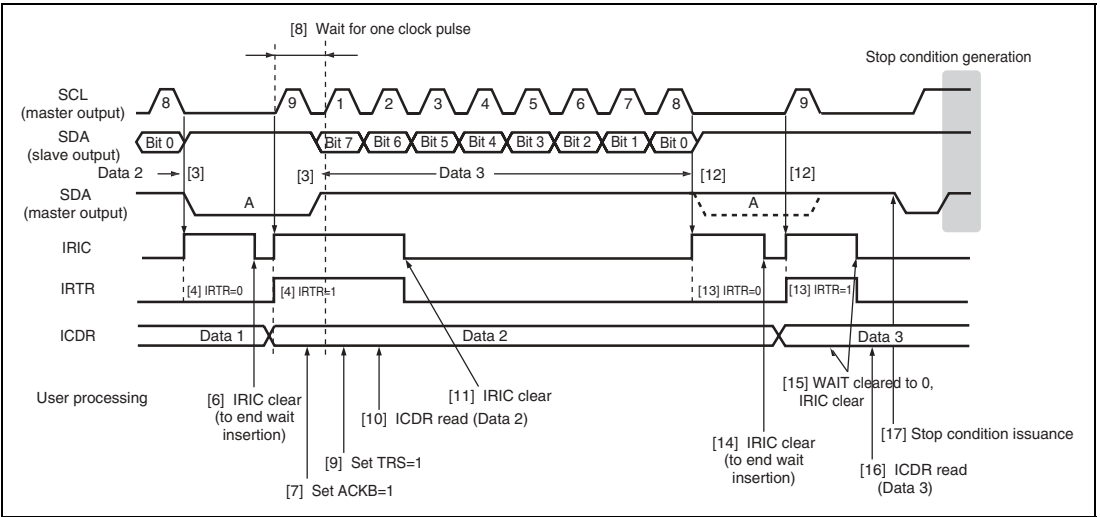

Figure 15.16 Stop Condition Issuance Timing Example in Master Receive Mode (MLS = ACKB = 0, WAIT = 1)

15.4.5 Slave Receive Operation

In I²C bus format slave receive mode, the master device outputs the transmit clock and transmit data, and the slave device returns an acknowledge signal.

The slave device operates as the device specified by the master device when the slave address in the first frame following the start condition that is issued by the master device matches its own address.

Receive Operation Using the HNDS Function (HNDS = 1):

Figure 15.17 shows the sample flowchart for the operations in slave receive mode (HNDS = 1).

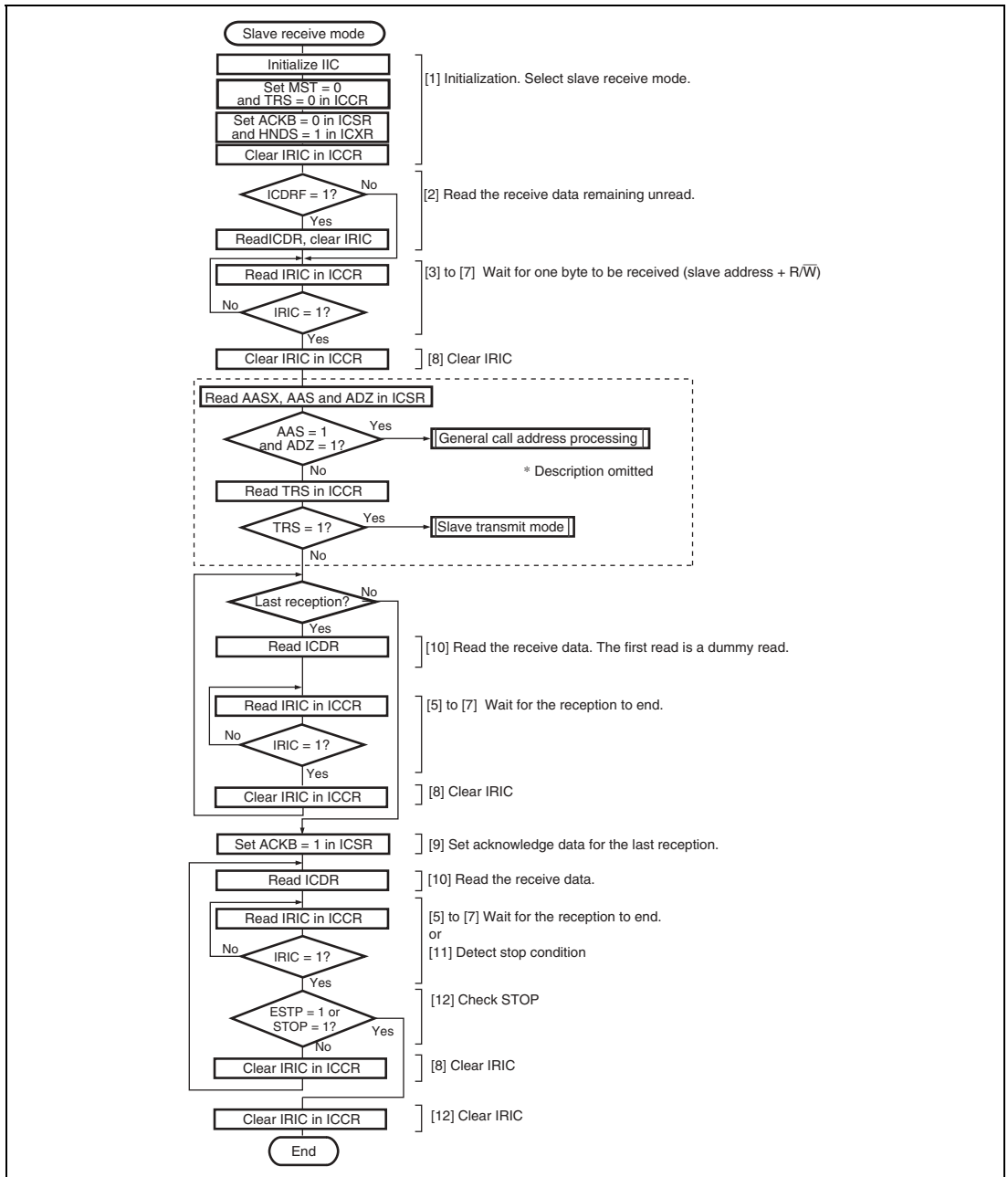

Figure 15.17 Sample Flowchart for Operations in Slave Receive Mode (HNDS = 1)

The reception procedure and operations using the HNDS bit function by which data reception process is provided in 1-byte unit with SCL being fixed low at every data reception, are described below.

- [1] Initialize the IIC as described in section 15.4.2, Initialization.
Clear the MST and TRS bits to 0 to set slave receive mode, and set the HNDS bit to 1 and the ACKB bit to 0. Clear the IRIC flag in ICCR to 0 to see the end of reception.
- [2] Confirm that the ICDRF flag is 0. If the ICDRF flag is set to 1, read the ICDR and then clear the IRIC flag to 0.
- [3] When the start condition output by the master device is detected, the BBSY flag in ICCR is set to 1. The master device then outputs the 7-bit slave address, and transmit/receive direction (R/\bar{W}), in synchronization with the transmit clock pulses.
- [4] When the slave address matches in the first frame following the start condition, the device operates as the slave device specified by the master device. If the 8th data bit (R/\bar{W}) is 0, the TRS bit remains cleared to 0, and slave receive operation is performed. If the 8th data bit (R/\bar{W}) is 1, the TRS bit is set to 1, and slave transmit operation is performed. When the slave address does not match, receive operation is halted until the next start condition is detected.
- [5] At the 9th clock pulse of the receive frame, the slave device returns the data in the ACKB bit as the acknowledge data.
- [6] At the rise of the 9th clock pulse, the IRIC flag is set to 1. If the IEIC bit has been set to 1, an interrupt request is sent to the CPU.
If the AASX bit has been set to 1, IRTR flag is also set to 1.
- [7] At the rise of the 9th clock pulse, the receive data is transferred from ICDRS to ICDRR, setting the ICDRF flag to 1. The slave device drives SCL low from the fall of the 9th receive clock pulse until data is read from ICDR.
- [8] Confirm that the STOP bit is cleared to 0, and clear the IRIC flag to 0.
- [9] If the next frame is the last receive frame, set the ACKB bit to 1.
- [10] If ICDR is read, the ICDRF flag is cleared to 0, releasing the SCL bus line. This enables the master device to transfer the next data.

Receive operations can be performed continuously by repeating steps [5] to [10].

- [11] When the stop condition is detected (SDA is changed from low to high when SCL is high), the BBSY flag is cleared to 0 and the STOP bit is set to 1. If the STOPIM bit has been cleared to 0, the IRIC flag is set to 1.
- [12] Confirm that the STOP bit is set to 1, and clear the IRIC flag to 0.

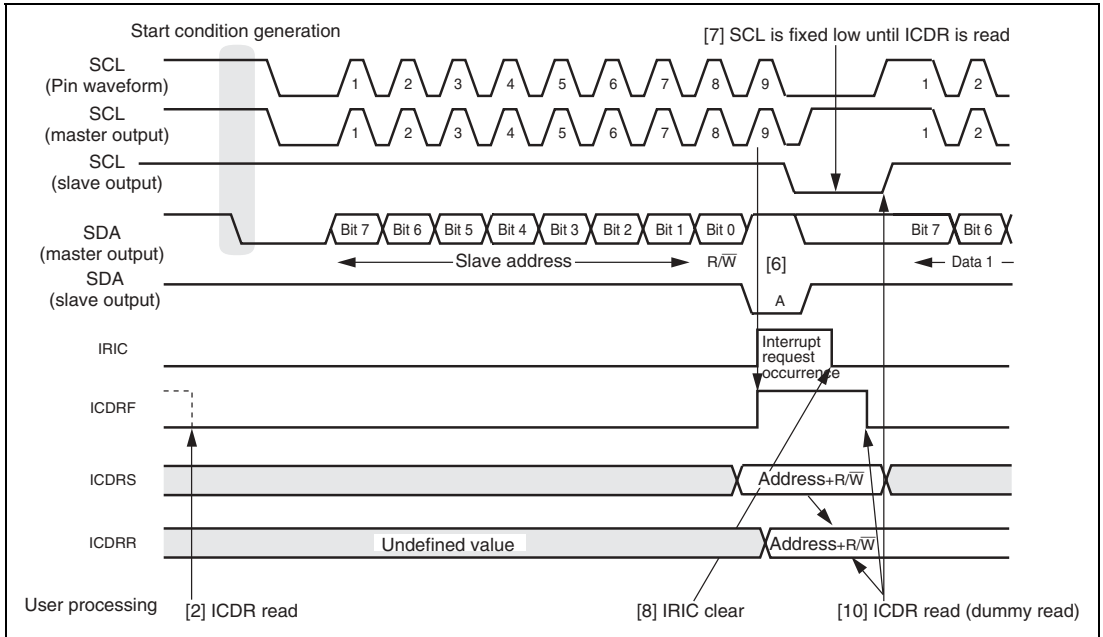

Figure 15.18 Slave Receive Mode Operation Timing Example (1)
 (MLS = 0, HNDS= 1)

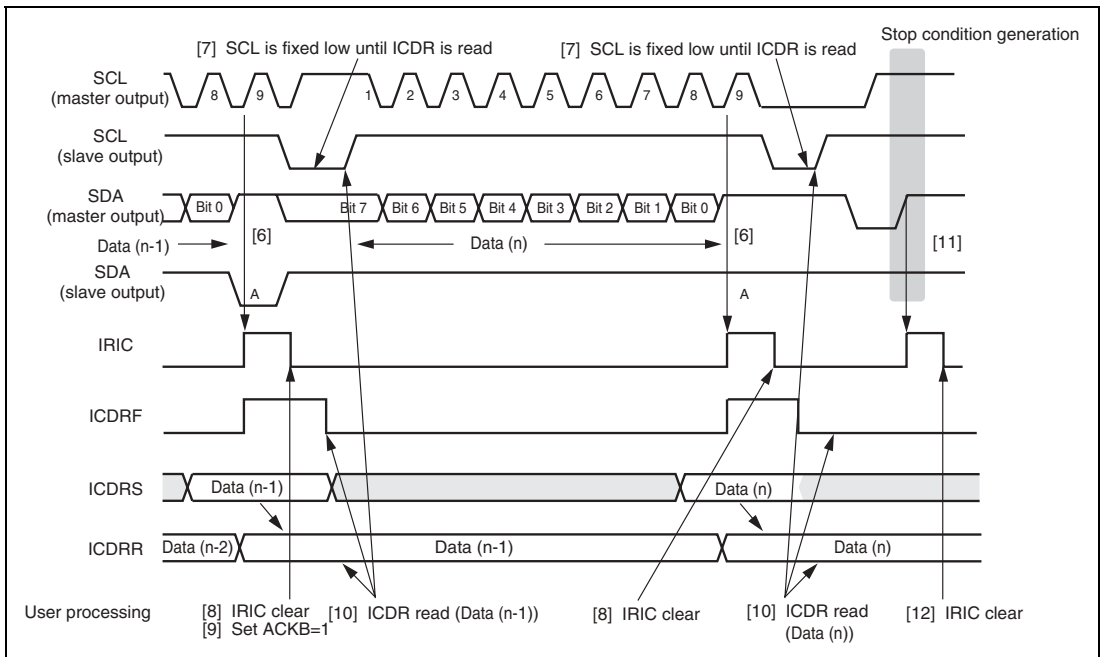

Figure 15.19 Slave Receive Mode Operation Timing Example (2)
 (MLS = 0, HNDS= 1)

Continuous Receive Operation:

Figure 15.20 shows the sample flowchart for the operations in slave receive mode (HNDS = 0).

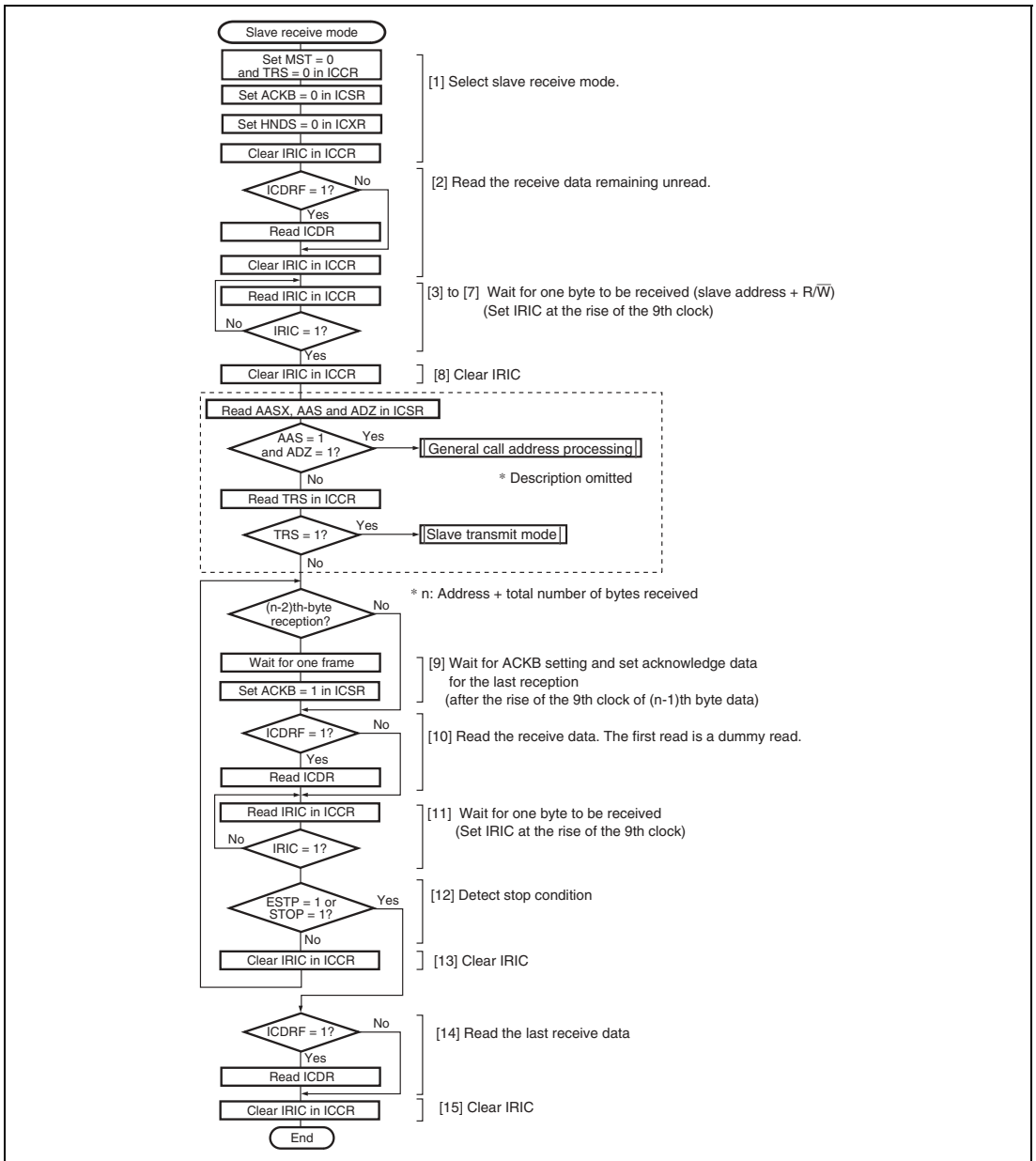

Figure 15.20 Sample Flowchart for Operations in Slave Receive Mode (HNDS = 0)

The reception procedure and operations in slave receive are described below.

- [1] Initialize the IIC as described in section 15.4.2, Initialization.
Clear the MST and TRS bits to 0 to set slave receive mode, and set the HNDS and ACKB bits to 0. Clear the IRIC flag in ICCR to 0 to see the end of reception.
- [2] Confirm that the ICDRF flag is 0. If the ICDRF flag is set to 1, read the ICDR and then clear the IRIC flag to 0.
- [3] When the start condition output by the master device is detected, the BBSY flag in ICCR is set to 1. The master device then outputs the 7-bit slave address, and transmit/receive direction (R/W) in synchronization with the transmit clock pulses.
- [4] When the slave address matches in the first frame following the start condition, the device operates as the slave device specified by the master device. If the 8th data bit (R/\overline{W}) is 0, the TRS bit remains cleared to 0, and slave receive operation is performed. If the 8th data bit (R/\overline{W}) is 1, the TRS bit is set to 1, and slave transmit operation is performed. When the slave address does not match, receive operation is halted until the next start condition is detected.
- [5] At the 9th clock pulse of the receive frame, the slave device returns the data in the ACKB bit as the acknowledge data.
- [6] At the rise of the 9th clock pulse, the IRIC flag is set to 1. If the IEIC bit has been set to 1, an interrupt request is sent to the CPU.
If the AASX bit has been set to 1, the IRTR flag is also set to 1.
- [7] At the rise of the 9th clock pulse, the receive data is transferred from ICDRS to ICDRR, setting the ICDRF flag to 1.
- [8] Confirm that the STOP bit is cleared to 0 and clear the IRIC flag to 0.
- [9] If the next read data is the third last receive frame, wait for at least one frame time to set the ACKB bit. Set the ACKB bit after the rise of the 9th clock pulse of the second last receive frame.
- [10] Confirm that the ICDRF flag is set to 1 and read ICDR. This clears the ICDRF flag to 0.
- [11] At the rise of the 9th clock pulse or when the receive data is transferred from IRDRS to ICDRR due to ICDR read operation, The IRIC and ICDRF flags are set to 1.
- [12] When the stop condition is detected (SDA is changed from low to high when SCL is high), the BBSY flag is cleared to 0 and the STOP or ESTP flag is set to 1. If the STOPIM bit has been cleared to 0, the IRIC flag is set to 1. In this case, execute step [14] to read the last receive data.
- [13] Clear the IRIC flag to 0.

Receive operations can be performed continuously by repeating steps [9] to [13].

- [14] Confirm that the ICDRF flag is set to 1, and read ICDR.
- [15] Clear the IRIC flag.

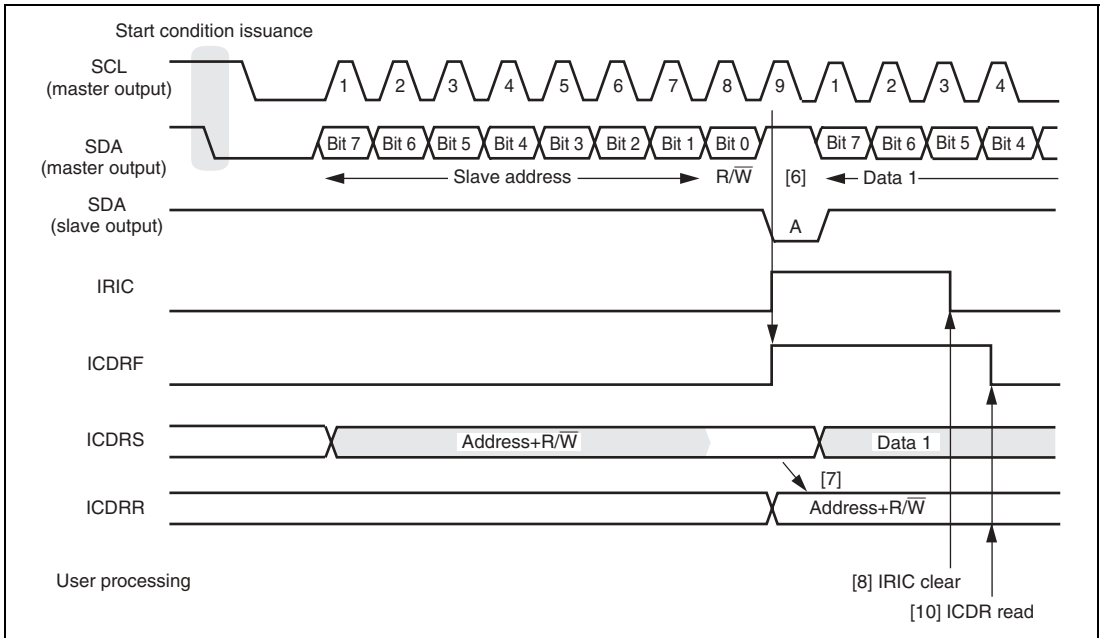

Figure 15.21 Slave Receive Mode Operation Timing Example (1)
 (MLS = ACKB = 0, HNDS = 0)

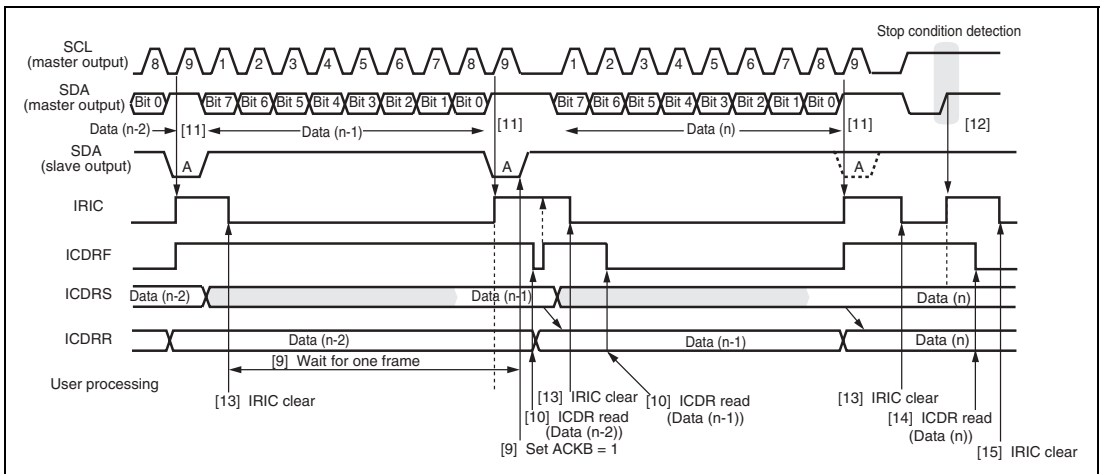

Figure 15.22 Slave Receive Mode Operation Timing Example (2)
 (MLS = ACKB = 0, HNDS = 0)

15.4.6 Slave Transmit Operation

If the slave address matches to the address in the first frame (address reception frame) following the start condition detection when the 8th bit data (R/W) is 1 (read), the TRS bit in ICCR is automatically set to 1 and the mode changes to slave transmit mode.

Figure 15.23 shows the sample flowchart for the operations in slave transmit mode.

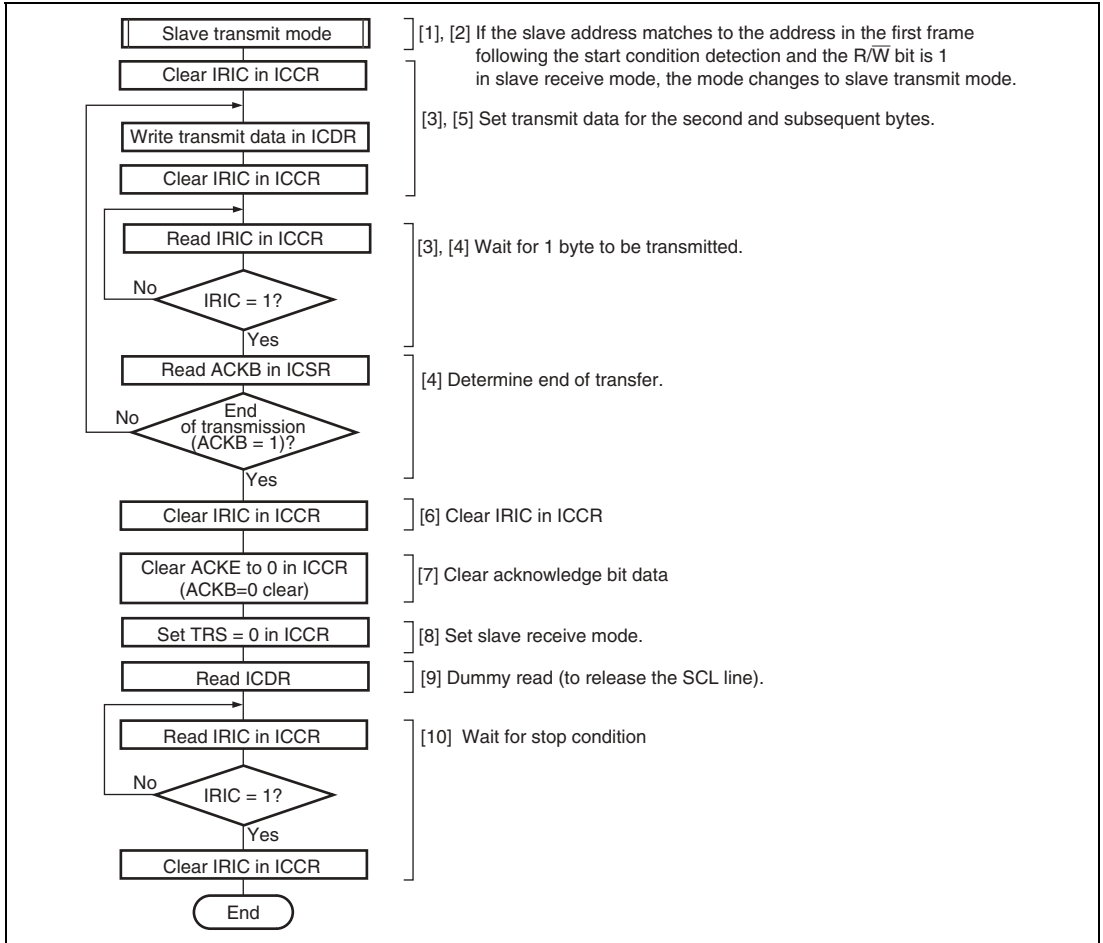

Figure 15.23 Sample Flowchart for Slave Transmit Mode

In slave transmit mode, the slave device outputs the transmit data, while the master device outputs the receive clock and returns an acknowledge signal. The transmission procedure and operations in slave transmit mode are described below.

- [1] Initialize slave receive mode and wait for slave address reception.
- [2] When the slave address matches in the first frame following detection of the start condition, the slave device drives SDA low at the 9th clock pulse and returns an acknowledge signal. If the 8th data bit (R/\overline{W}) is 1, the TRS bit in ICCR is set to 1, and the mode changes to slave transmit mode automatically. The IRIC flag is set to 1 at the rise of the 9th clock. If the IEIC bit in ICCR has been set to 1, an interrupt request is sent to the CPU. At the same time, the ICDRE flag is set to 1. The slave device drives SCL low from the fall of the 9th transmit clock until ICDR data is written, to disable the master device to output the next transfer clock.

- [3] After clearing the IRIC flag to 0, write data to ICDR. At this time, the ICDRE flag is cleared to 0. The written data is transferred to ICDRS, and the ICDRE and IRIC flags are set to 1 again. The slave device sequentially sends the data written into ICDRS in accordance with the clock output by the master device.

The IRIC flag is cleared to 0 to detect the end of transmission. Processing from the ICDR register writing to the IRIC flag clearing should be performed continuously. Prevent any other interrupt processing from being inserted.

- [4] The master device drives SDA low at the 9th clock pulse, and returns an acknowledge signal. As this acknowledge signal is stored in the ACKB bit in ICSR, this bit can be used to determine whether the transfer operation was performed successfully. When one frame of data has been transmitted, the IRIC flag in ICCR is set to 1 at the rise of the 9th transmit clock pulse. When the ICDRE flag is 0, the data written into ICDR is transferred to ICDRS and the ICDRE and IRIC flags are set to 1 again. If the ICDRE flag has been set to 1, this slave device drives SCL low from the fall of the 9th transmit clock until data is written to ICDR.

- [5] To continue transmission, write the next data to be transmitted into ICDR. The ICDRE flag is cleared to 0. The IRIC flag is cleared to 0 to detect the end of transmission. Processing from the ICDR register writing to the IRIC flag clearing should be performed continuously. Prevent any other interrupt processing from being inserted.

Transmit operations can be performed continuously by repeating steps [4] and [5].

- [6] Clear the IRIC flag to 0.
- [7] To end transmission, clear the ACKE bit in the ICCR register to 0, to clear the acknowledge bit stored in the ACKB bit to 0.
- [8] Clear the TRS bit to 0 for the next address reception, to set slave receive mode.
- [9] Dummy-read ICDR to release SCL on the slave side.
- [10] When the stop condition is detected, that is, when SDA is changed from low to high when SCL is high, the BBSY flag in ICCR is cleared to 0 and the STOP flag in ICSR is set to 1. When the STOPIM bit in ICXR is 0, the IRIC flag is set to 1. If the IRIC flag has been set, it is cleared to 0.

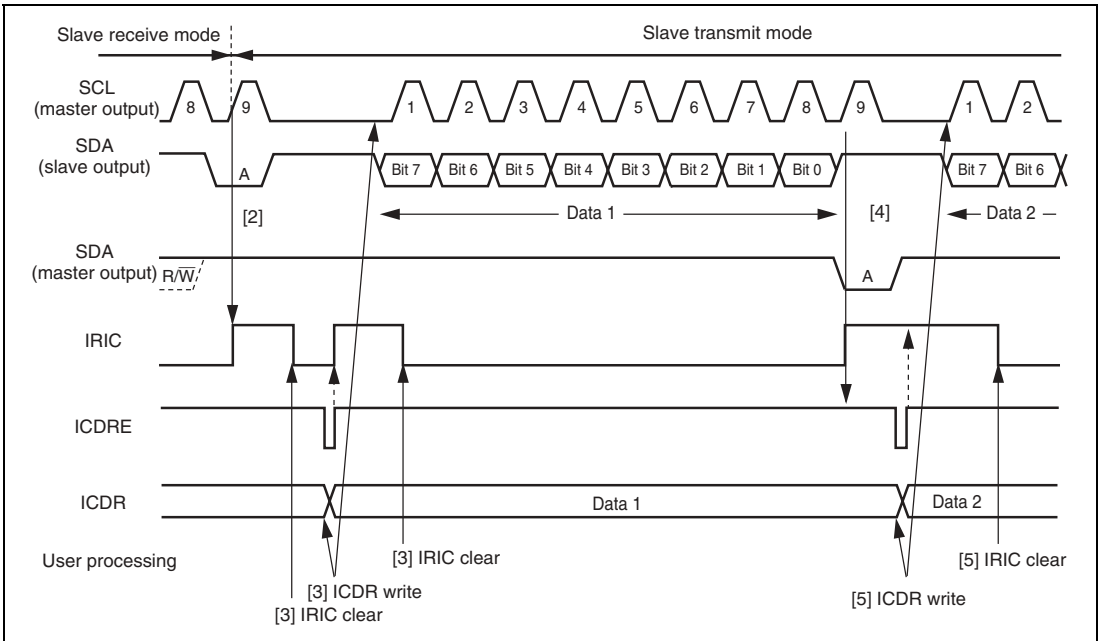

Figure 15.24 Slave Transmit Mode Operation Timing Example (MLS = 0)

15.4.7 IRIC Setting Timing and SCL Control

The interrupt request flag (IRIC) is set at different times depending on the WAIT bit in ICMR, the FS bit in SAR, and the FSX bit in SARX. If the ICDRE or ICDRF flag is set to 1, SCL is automatically held low after one frame has been transferred; this timing is synchronized with the internal clock. Figures 15.25 to 15.27 show the IRIC set timing and SCL control.

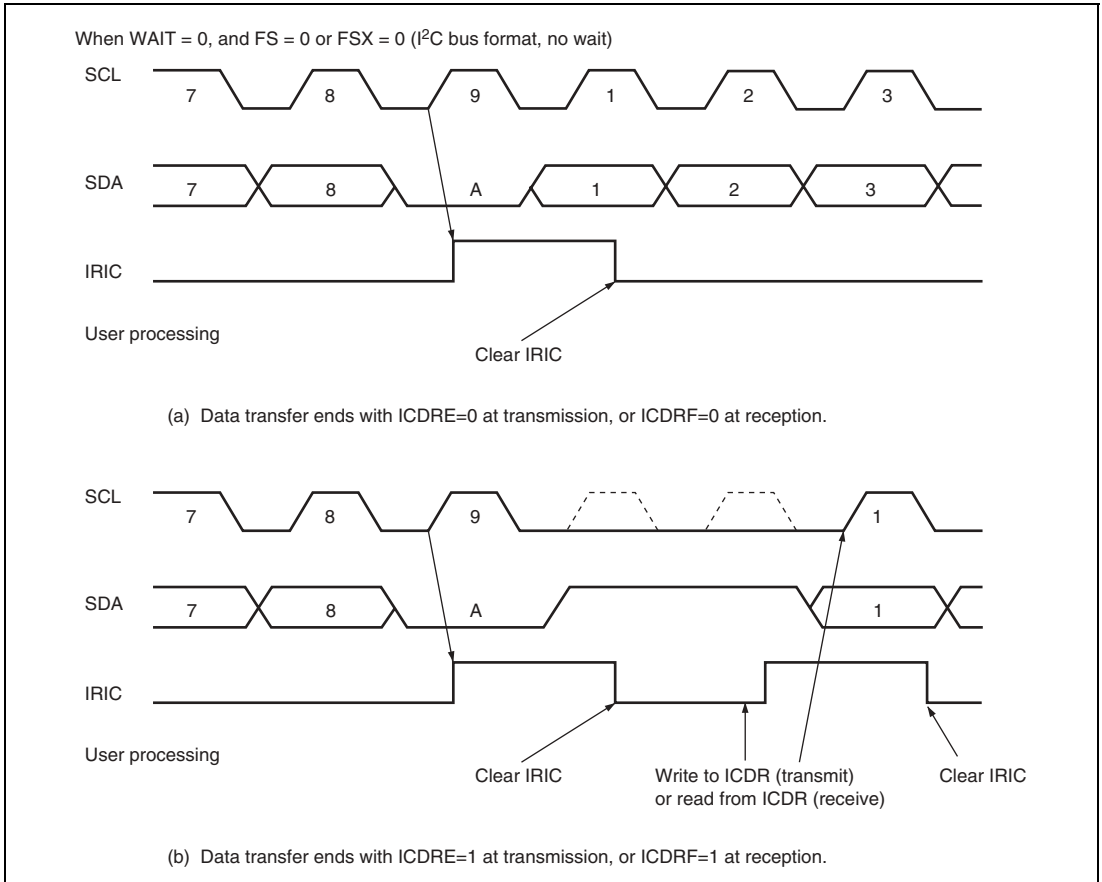
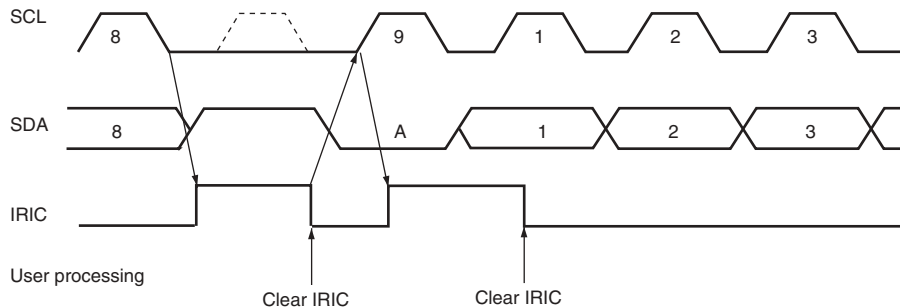
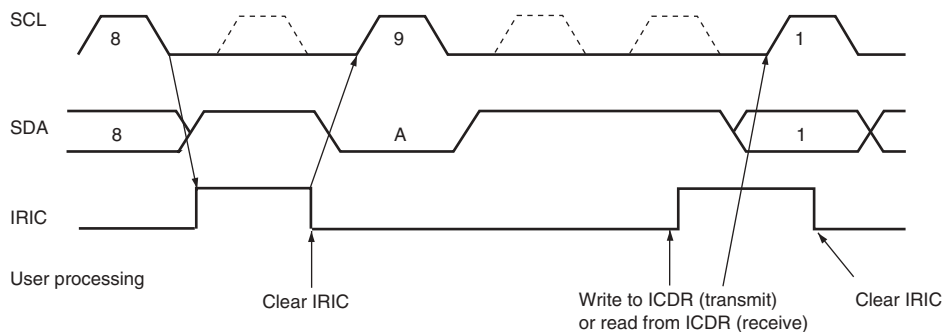

Figure 15.25 IRIC Setting Timing and SCL Control (1)

When WAIT = 1, and FS = 0 or FSX = 0 (I²C bus format, wait inserted)



(a) Data transfer ends with ICDRE=0 at transmission, or ICDRF=0 at reception.



(b) Data transfer ends with ICDRE=1 at transmission, or ICDRF=1 at reception.

Figure 15.26 IRIC Setting Timing and SCL Control (2)

When FS = 1 and FSX = 1 (clocked synchronous serial format)

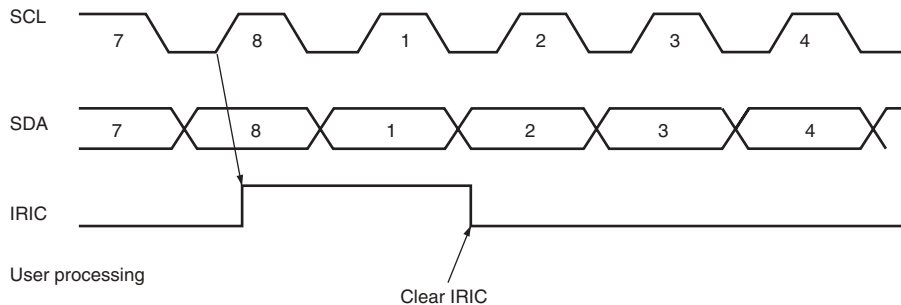

(a) Data transfer ends with ICDRE=0 at transmission, or ICDRF=0 at reception.

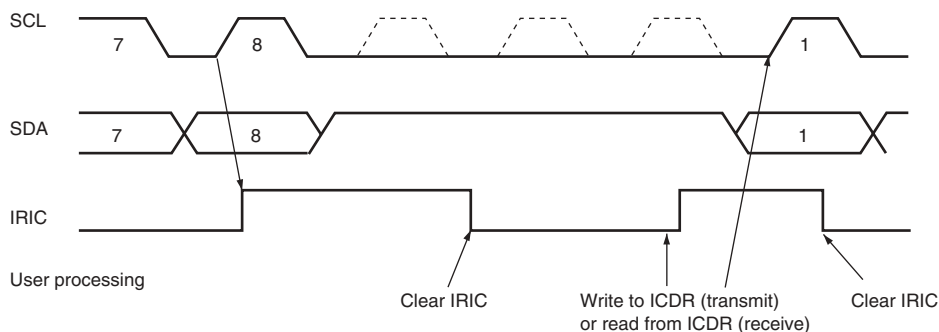

(b) Data transfer ends with ICDRE=1 at transmission, or ICDRF=1 at reception.

Figure 15.27 IRIC Setting Timing and SCL Control (3)

15.4.8 Operation Using the DTC

This LSI provides the DTC to allow continuous data transfer. IIC_4 and IIC_5 cannot use the DTC. The DTC is initiated when the IRTR flag is set to 1, which is one of the two interrupt flags (IRTR and IRIC). When the ACKE bit is 0, the ICDRE, IRIC, and IRTR flags are set at the end of data transmission regardless of the acknowledge bit value. When the ACKE bit is 1, the ICDRE, IRIC, and IRTR flags are set if data transmission is completed with the acknowledge bit value of 0, and when the ACKE bit is 1, only the IRIC flag is set if data transmission is completed with the acknowledge bit value of 1.

When initiated, DTC transfers specified number of bytes, clears the ICDRE, IRIC, and IRTR flags to 0. Therefore, no interrupt is generated during continuous data transfer; however, if data transmission is completed with the acknowledge bit value of 1 when the ACKE bit is 1, DTC is not initiated, thus allowing an interrupt to be generated if enabled.

The acknowledge bit may indicate specific events such as completion of receive data processing for some receiving devices, and for other receiving devices, the acknowledge bit may be held to 1, indicating no specific events.

The I²C bus format provides for selection of the slave device and transfer direction by means of the slave address and the R/W bit, confirmation of reception with the acknowledge bit, indication of the last frame, and so on. Therefore, continuous data transfer using the DTC must be carried out in conjunction with CPU processing by means of interrupts.

Table 15.9 shows some examples of processing using the DTC. These examples assume that the number of transfer data bytes is known in slave mode.

Table 15.9 Examples of Operation Using the DTC

Item	Master Transmit Mode	Master Receive Mode	Slave Transmit Mode	Slave Receive Mode
Slave address + R/W bit transmission/reception	Transmission by DTC (ICDR write)	Transmission by CPU (ICDR write)	Reception by CPU (ICDR read)	Reception by CPU (ICDR read)
Dummy data read	—	Processing by CPU (ICDR read)	—	—
Actual data transmission/reception	Transmission by DTC (ICDR write)	Reception by DTC (ICDR read)	Transmission by DTC (ICDR write)	Reception by DTC (ICDR read)
Dummy data (H'FF) write	—	—	Processing by DTC (ICDR write)	—
Last frame processing	Not necessary	Reception by CPU (ICDR read)	Not necessary	Reception by CPU (ICDR read)
Transfer request processing after last frame processing	1st time: Clearing by CPU 2nd time: Stop condition issuance by CPU	Not necessary	Automatic clearing on detection of stop condition during transmission of dummy data (H'FF)	Not necessary
Setting of number of DTC transfer data frames	Transmission: Actual data count + 1 (+1 equivalent to slave address + R/W bits)	Reception: Actual data count	Transmission: Actual data count + 1 (+1 equivalent to dummy data (H'FF))	Reception: Actual data count

15.4.9 Noise Canceler

The logic levels at the SCL and SDA pins are routed through noise cancelers before being latched internally. Figure 15.28 shows a block diagram of the noise canceler.

The noise canceler consists of two cascaded latches and a match detector. The SCL (or SDA) pin input signal is sampled on the system clock, but is not passed forward to the next circuit unless the outputs of both latches agree. If they do not agree, the previous value is held.

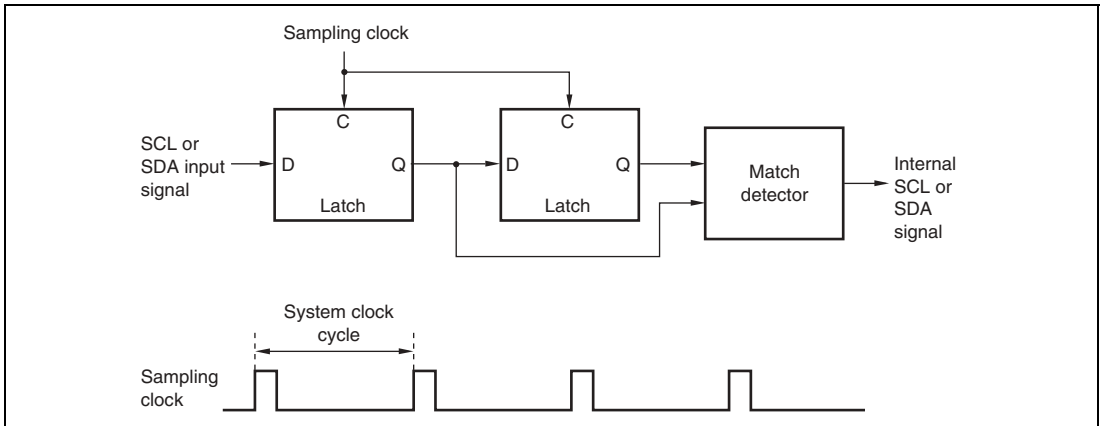

Figure 15.28 Block Diagram of Noise Canceler

15.4.10 Initialization of Internal State

The IIC has a function for forcible initialization of its internal state if a deadlock occurs during communication.

Initialization is executed in accordance with clearing ICE bit.

Scope of Initialization: The initialization executed by this function covers the following items:

- ICDRE and ICDRF internal flags
- Transmit/receive sequencer and internal operating clock counter
- Internal latches for retaining the output state of the SCL and SDA pins (wait, clock, data output, etc.)

The following items are not initialized:

- Actual register values (ICDR, SAR, SARX, ICMR, ICCR, ICSR, ICXR (other than ICDRE and ICDRF))
- Internal latches used to retain register read information for setting/clearing flags in the ICMR, ICCR, and ICSR registers

- The value of the ICMR register bit counter (BC2 to BC0)
- Generated interrupt sources (interrupt sources transferred to the interrupt controller)

Notes on Initialization:

- Interrupt flags and interrupt sources are not cleared, and so flag clearing measures must be taken as necessary.
- Basically, other register flags are not cleared either, and so flag clearing measures must be taken as necessary.
- If a flag clearing setting is made during transmission/reception, the IIC module will stop transmitting/receiving at that point and the SCL and SDA pins will be released. When transmission/reception is started again, register initialization, etc., must be carried out as necessary to enable correct communication as a system.

The value of the BBSY bit cannot be modified directly by this module clear function, but since the stop condition pin waveform is generated according to the state and release timing of the SCL and SDA pins, the BBSY bit may be cleared as a result. Similarly, state switching of other bits and flags may also have an effect.

To prevent problems caused by these factors, the following procedure should be used when initializing the IIC state.

1. Execute initialization of the internal state according to the ICE bit clearing.
2. Execute a stop condition issuance instruction (write 0 to BBSY and SCP) to clear the BBSY bit to 0, and wait for two transfer rate clock cycles.
3. Re-execute initialization of the internal state according to the ICE bit clearing.
4. Initialize (re-set) the IIC registers.

15.5 Interrupt Source

The IIC interrupt source is IICI. The IIC interrupt sources and their priority order are shown in table 15.10. Each interrupt source is enabled or disabled by the ICCR interrupt enable bit and transferred to the interrupt controller independently.

The IICI0 to IICI3 interrupts can be used as sources of activating the on-chip DTC.

Table 15.10 IIC Interrupt Source

Channel	Bit Name	Enable Bit	Interrupt Source	Interrupt Flag	DTC Activation	Priority
2	IICI2	IEIC	I ² C bus interface interrupt request	IRIC	Possible	High
3	IICI3	IEIC	I ² C bus interface interrupt request	IRIC	Possible	
0	IICI0	IEIC	I ² C bus interface interrupt request	IRIC	Possible	
1	IICI1	IEIC	I ² C bus interface interrupt request	IRIC	Possible	
4	IICI4	IEIC	I ² C bus interface interrupt request	IRIC	Not possible	
5	IICI5	IEIC	I ² C bus interface interrupt request	IRIC	Not possible	Low

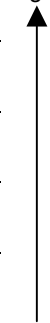

15.6 Usage Notes

1. In master mode, if an instruction to generate a start condition is immediately followed by an instruction to generate a stop condition, neither condition will be output correctly. To output consecutive start and stop conditions*, after issuing the instruction that generates the start condition, read the relevant DR registers of I²C bus output pins, check that SCL and SDA are both low. If the ICE bit is set to 1, pin state can be monitored by reading DR register. Then issue the instruction that generates the stop condition. Note that SCL may not yet have gone low when BBSY is cleared to 0.

Note: * An illegal procedure in the I²C bus specification.

2. Either of the following two conditions will start the next transfer. Pay attention to these conditions when accessing to ICDR.
 - Write to ICDR when ICE = 1 and TRS = 1 (including automatic transfer from ICDRT to ICDRS)
 - Read from ICDR when ICE = 1 and TRS = 0 (including automatic transfer from ICDRS to ICDRR)
3. Table 15.11 shows the timing of SCL and SDA outputs in synchronization with the internal clock. Timings on the bus are determined by the rise and fall times of signals affected by the bus load capacitance, series resistance, and parallel resistance.

Table 15.11 I²C Bus Timing (SCL and SDA Outputs)

Item	Symbol	Output Timing	Unit	Notes
SCL output cycle time	t_{SCLC}	$28t_{cyc}$ to $512t_{cyc}$	ns	See figure
SCL output high pulse width	t_{SCLHO}	$0.5t_{SCLC}$	ns	25.30 (reference)
SCL output low pulse width	t_{SCLLO}	$0.5t_{SCLC}$	ns	
SDA output bus free time	t_{BUFO}	$0.5t_{SCLC} - 1t_{cyc}$	ns	
Start condition output hold time	t_{STAHO}	$0.5t_{SCLC} - 1t_{cyc}$	ns	
Retransmission start condition output setup time	t_{STASO}	$1t_{SCLC}$	ns	
Stop condition output setup time	t_{STOSO}	$0.5t_{SCLC} + 2t_{cyc}$	ns	
Data output setup time (master)	t_{SDASO}	$1t_{SCLLO} - 3t_{cyc}$	ns	
Data output setup time (slave)		$1t_{SCLLO} - (6t_{cyc} \text{ or } 12t_{cyc}^*)$		
Data output hold time	t_{SDAHO}	$3t_{cyc}$	ns	

Note: * $6t_{cyc}$ when IICXn is 0, $12t_{cyc}$ when IICXn is 1 (n = 0 to 5).

4. SCL and SDA input is sampled in synchronization with the internal clock. The AC timing therefore depends on the system clock cycle t_{cyc} , as shown in section 25, Electrical Characteristics. Note that the I²C bus interface AC timing specification will not be met with a system clock frequency of less than 5 MHz.
5. The I²C bus interface specification for the SCL rise time t_{sr} is 1000 ns or less (300 ns for high-speed mode). In master mode, the I²C bus interface monitors the SCL line and synchronizes one bit at a time during communication. If t_{sr} (the time for SCL to go from low to V_{IH}) exceeds the time determined by the input clock of the I²C bus interface, the high period of SCL is extended. The SCL rise time is determined by the pull-up resistance and load capacitance of the SCL line. To insure proper operation at the set transfer rate, adjust the pull-up resistance and load capacitance so that the SCL rise time does not exceed the values given in table 15.12.

Table 15.12 Permissible SCL Rise Time (t_{sr}) Values

TCSS	IICXn	t_{cyc} Indi- cation	I ² C Bus Spe- cifica- tion (Max.)	Time Indication [ns]							
				$\phi = 5$	$\phi = 8$	$\phi = 10$	$\phi = 16$	$\phi = 20$	$\phi = 25$	$\phi = 33$	
				MHz	MHz	MHz	MHz	MHz	MHz	MHz	
0	0	7.5 t_{cyc}	Standard mode	1000	1000	937	750	468	375	300	227
			High-speed mode	300	300	300	300	300	300	300	227
1	1	17.5 t_{cyc}	Standard mode	1000	1000	1000	1000	1000	875	700	530
			High-speed mode	300	300	300	300	300	300	300	300
1	1	37.5 t_{cyc}	Standard mode	1000	1000	1000	1000	1000	1000	1000	1000
			High-speed mode	300	300	300	300	300	300	300	300

Note: n = 0 to 5

6. The I²C bus interface specifications for the SCL and SDA rise and fall times are under 1000 ns and 300 ns. The I²C bus interface SCL and SDA output timing is prescribed by t_{cyc} , as shown in table 15.11. However, because of the rise and fall times, the I²C bus interface specifications may not be satisfied at the maximum transfer rate. Table 15.13 shows output timing calculations for different operating frequencies, including the worst-case influence of rise and fall times.

t_{BUFO} fails to meet the I²C bus interface specifications at any frequency. The solution is either (a) to provide coding to secure the necessary interval (approximately 1 μs) between issuance of a stop condition and issuance of a start condition, or (b) to select devices whose input timing permits this output timing for use as slave devices connected to the I²C bus.

t_{SCLLO} in high-speed mode and t_{STASO} in standard mode fail to satisfy the I²C bus interface specifications for worst-case calculations of $t_{\text{sr}}/t_{\text{sf}}$. Possible solutions that should be investigated include (a) adjusting the rise and fall times by means of a pull-up resistor and capacitive load, (b) reducing the transfer rate to meet the specifications, or (c) selecting devices whose input timing permits this output timing for use as slave devices connected to the I²C bus.

Table 15.13 I²C Bus Timing (with Maximum Influence of t_{sr}/t_{sf})

		Time Indication (at Maximum Transfer Rate) [ns]										
Item	t_{cyc} Indi- cation		t_{sr}/t_{sf} Influence (Max.)	I ² C Bus Specifi- cation (Min.)	$\phi =$	$\phi =$	$\phi =$	$\phi =$	$\phi =$	$\phi =$	$\phi =$	
					5 MHz	8 MHz	10 MHz	16 MHz	20 MHz	25 MHz	33 MHz	
t_{SCLHO}	$0.5 t_{SCLO}$ ($-t_{sr}$)	Standard mode	-1000	4000	4000	4000	4000	4000	4000	4000	4000	4000* ¹
		High-speed mode	-300	600	2500	1450	1100	950	950	950	950	950
t_{SCLLO}	$0.5 t_{SCLO}$ ($-t_{sr}$)	Standard mode	-250	4700	4750	4750	4750	4750	4750	4750	4750	4750* ¹
		High-speed mode	-250	1300	2550	1500	1150* ¹	1000* ¹	1000* ¹	1000* ¹	1000* ¹	1000* ¹
t_{BUFO}	$0.5 t_{SCLO}$ $-1 t_{cyc}$ ($-t_{sr}$)	Standard mode	-1000	4700	3800* ¹	3875* ¹	3900* ¹	3938* ¹	3950* ¹	3960* ¹	3970* ¹	3970* ¹
		High-speed mode	-300	1300	2300	1325	1000* ¹	888* ¹	900* ¹	910* ¹	920* ¹	920* ¹
t_{STAH0}	$0.5 t_{SCLO}$ $-1 t_{cyc}$ ($-t_{sr}$)	Standard mode	-250	4000	4550	4625	4650	4688	4700	4710	4720* ¹	4720* ¹
		High-speed mode	-250	600	2350	1375	1050	938	950	960	970	970
t_{STAS0}	$1 t_{SCLO}$ ($-t_{sr}$)	Standard mode	-1000	4700	9000	9000	9000	9000	9000	9000	9000	9000
		High-speed mode	-300	600	5300	3200	2500	2200	2200	2200	2200	2200
t_{STOS0}	$0.5 t_{SCLO}$ $+ 2 t_{cyc}$ ($-t_{sr}$)	Standard mode	-1000	4000	4400	4250	4200	4125	4100	4080	4061* ¹	4061* ¹
		High-speed mode	-300	600	2900	1700	1300	1075	1050	1030	1011	1011
t_{SDAS0} (master)	$1 t_{SCLLO}$ * ³ $-3 t_{cyc}$ ($-t_{sr}$)	Standard mode	-1000	250	3150	3375	3450	3563	3600	3630	3659	3659
		High-speed mode	-300	100	1650	825	550	513	550	580	609	609
t_{SDAS0} (slave)	$1 t_{SCLL}$ * ³ $-12 t_{cyc}$ * ² ($-t_{sr}$)	Standard mode	-1000	250	1300	2200	2500	2950	3100	3220	3336	3336
		High-speed mode	-300	100	-1400* ¹	-500* ¹	-200* ¹	250	400	520	636	636

Time Indication (at Maximum Transfer Rate) [ns]

Item	t_{cyc} Indi- cation	t_{s}/t_{sf} Influence (Max.)	t_{s}/t_{sf} Influence (Max.)	I ² C Bus Specifi- cation							
				$\phi =$ 5 MHz	$\phi =$ 8 MHz	$\phi =$ 10 MHz	$\phi =$ 16 MHz	$\phi =$ 20 MHz	$\phi =$ 25 MHz	$\phi =$ 33 MHz	
				(Min.)	(Min.)	(Min.)	(Min.)	(Min.)	(Min.)	(Min.)	
t_{SDAHO}	3 t_{cyc}	Standard mode	0	0	600	375	300	188	150	120	91
		High-speed mode	0	0	600	375	300	188	150	120	91

Notes: 1. Does not meet the I²C bus interface specification. Remedial action such as the following is necessary: (a) secure a start/stop condition issuance interval; (b) adjust the rise and fall times by means of a pull-up resistor and capacitive load; (c) reduce the transfer rate; (d) select slave devices whose input timing permits this output timing.

The values in the above table will vary depending on the settings of the bits TCSS, IICX5 to IICX0 and CKS0 to CKS2. Depending on the frequency it may not be possible to achieve the maximum transfer rate; therefore, whether or not the I²C bus interface specifications are met must be determined in accordance with the actual setting conditions.

2. Value when the IICXn bit is set to 1. When the IICXn bit is cleared to 0, the value is $(-6t_{cyc})$ ($n = 0$ to 5).
3. Calculated using the I²C bus specification values (standard mode: 4700 ns min.; high-speed mode: 1300 ns min.).

7. Notes on ICDR register read at end of master reception

To halt reception at the end of a receive operation in master receive mode, set the TRS bit to 1 and write 0 to BBSY and SCP in ICCR. This changes SDA from low to high when SCL is high, and generates the stop condition. After this, receive data can be read by means of an ICDR read, but if data remains in the buffer the ICDRS receive data will not be transferred to ICDR, and so it will not be possible to read the second byte of data.

If it is necessary to read the second byte of data, issue the stop condition in master receive mode (i.e. with the TRS bit cleared to 0). When reading the receive data, first confirm that the BBSY bit in the ICCR register is cleared to 0, the stop condition has been generated, and the bus has been released, then read the ICDR register with TRS cleared to 0.

Note that if the receive data (ICDR data) is read in the interval between execution of the instruction for issuance of the stop condition (writing of 0 to BBSY and SCP in ICCR) and the actual generation of the stop condition, the clock may not be output correctly in subsequent master transmission.

Clearing of the MST bit after completion of master transmission/reception, or other modifications of IIC control bits to change the transmit/receive operating mode or settings, must be carried out during interval (a) in figure 15.29 (after confirming that the BBSY bit has been cleared to 0 in the ICCR register).

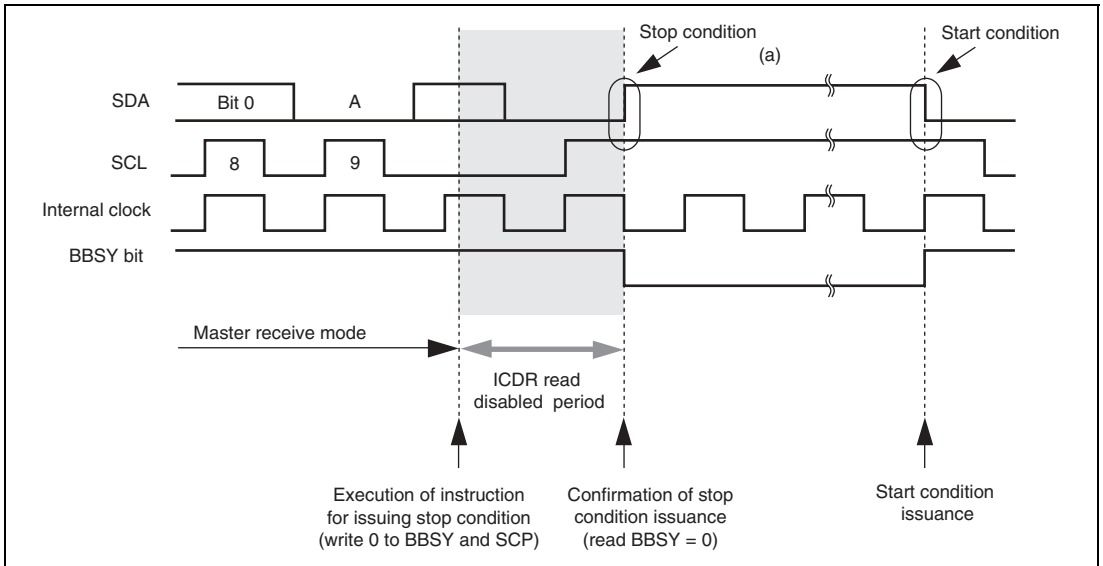

Figure 15.29 Notes on Reading Master Receive Data

Note: This restriction on usage can be canceled by setting the FNC1 and FNC0 bits to B'11 in ICXR.

8. Notes on start condition issuance for retransmission

Figure 15.30 shows the timing of start condition issuance for retransmission, and the timing for subsequently writing data to ICDR, together with the corresponding flowchart. Write the transmit data to ICDR after the start condition for retransmission is issued and then the start condition is actually generated.

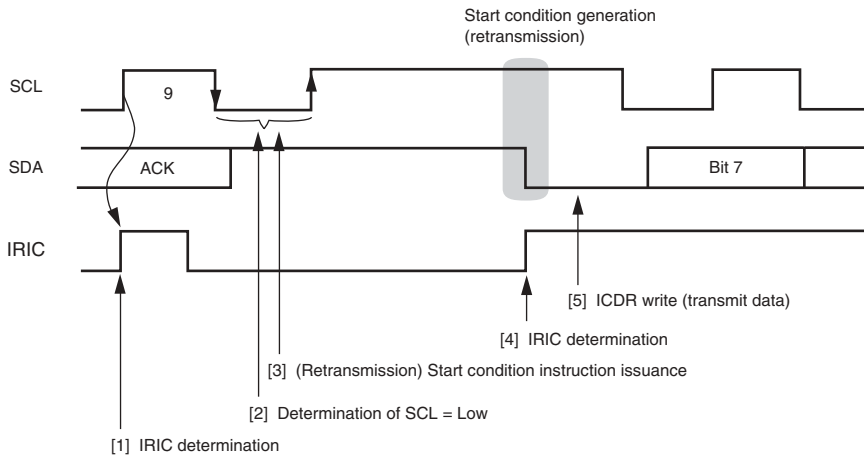
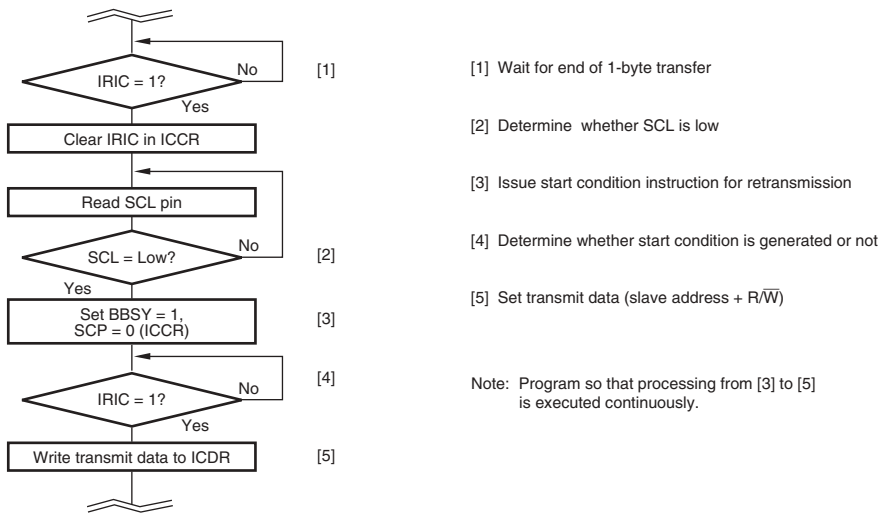

Figure 15.30 Flowchart for Start Condition Issuance Instruction for Retransmission and Timing

Note: This restriction on usage can be canceled by setting the FNC1 and FNC0 bits to B'11 in ICXR.

9. Note on when I²C bus interface stop condition instruction is issued

In a situation where the rise time of the 9th clock of SCL exceeds the stipulated value because of a large bus load capacity or where a slave device in which a wait can be inserted by driving the SCL pin low is used, the stop condition instruction should be issued after reading SCL after the rise of the 9th clock pulse and determining that it is low.

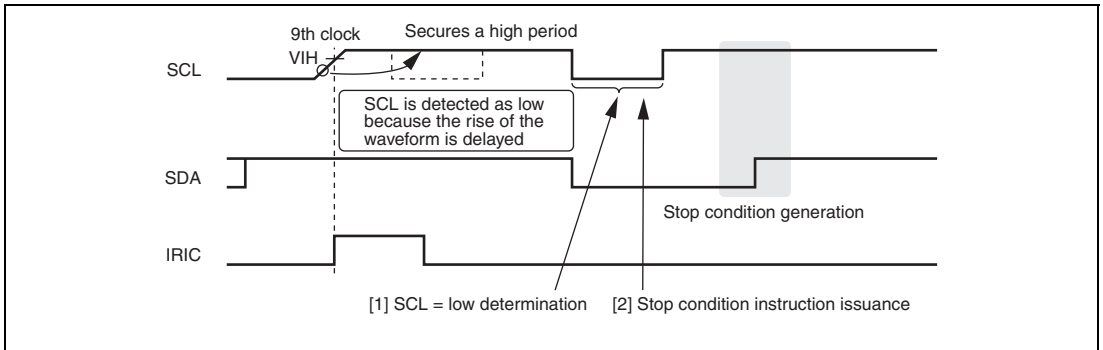

Figure 15.31 Stop Condition Issuance Timing

Note: This restriction on usage can be canceled by setting the FNC1 and FNC0 bits to B'11 in ICXR.

10. Note on IRIC flag clear when the wait function is used

When the wait function is used in I²C bus interface master mode and in a situation where the rise time of SCL exceeds the stipulated value or where a slave device in which a wait can be inserted by driving the SCL pin low is used, the IRIC flag should be cleared after determining that the SCL is low.

If the IRIC flag is cleared to 0 when WAIT = 1 while the SCL is extending the high level time, the SDA level may change before the SCL goes low, which may generate a start or stop condition erroneously.

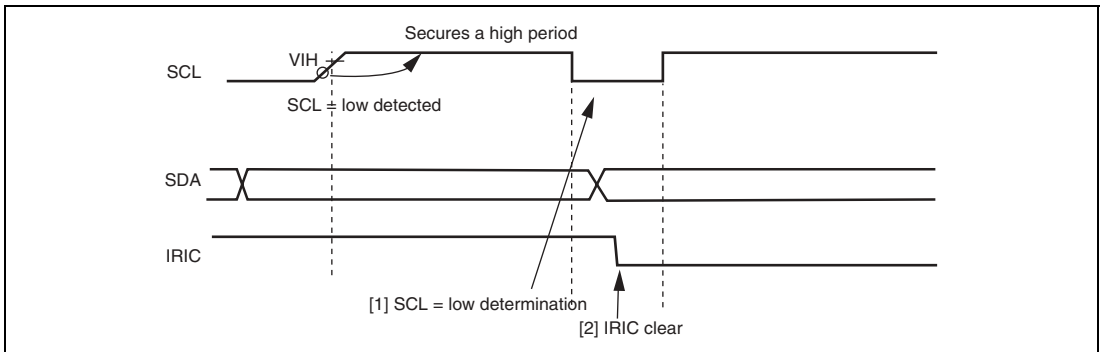

Figure 15.32 IRIC Flag Clearing Timing When WAIT = 1

Note: This restriction on usage can be canceled by setting the FNC1 and FNC0 bits to B'11 in ICXR.

11. Note on ICDR register read and ICCR register access in slave transmit mode

In I²C bus interface slave transmit mode, do not read ICDR or do not read/write from/to ICCR during the time shaded in figure 15.33. However, such read and write operations source no problem in interrupt handling processing that is generated in synchronization with the rising edge of the 9th clock pulse because the shaded time has passed before making the transition to interrupt handling.

To handle interrupts securely, be sure to keep either of the following conditions.

- Read ICDR data that has been received so far or read/write from/to ICCR before starting the receive operation of the next slave address.
- Monitor the BC2 to BC0 counter in ICMR; when the count is B'000 (8th or 9th clock pulse), wait for at least two transfer clock times in order to read ICDR or read/write from/to ICCR during the time other than the shaded time.

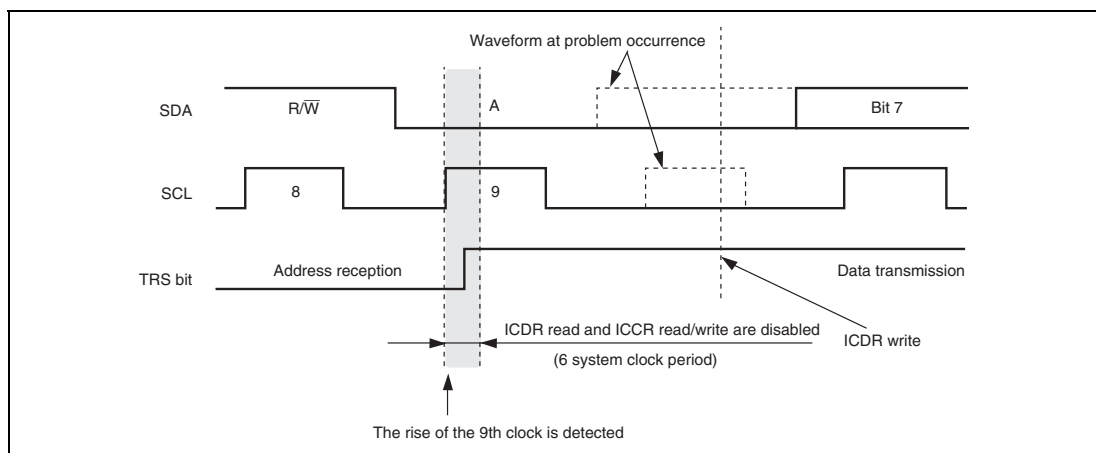

Figure 15.33 ICDR Register Read and ICCR Register Access Timing in Slave Transmit Mode

Note: This restriction on usage can be canceled by setting the FNC1 and FNC0 bits to B'11 in ICXR.

12. Note on TRS bit setting in slave mode

In I²C bus interface slave mode, if the TRS bit value in ICCR is set after detecting the rising edge of the 9th clock pulse or the stop condition before detecting the next rising edge on the SCL pin (the time indicated as (a) in figure 15.34), the bit value becomes valid immediately when it is set. However, if the TRS bit is set during the other time (the time indicated as (b) in figure 15.34), the bit value is suspended and remains invalid until the rising edge of the 9th clock pulse or the stop condition is detected. Therefore, when the address is received after the restart condition is input without the stop condition, the effective TRS bit value remains 1 (transmit mode) internally and thus the acknowledge bit is not transmitted after the address has been received at the 9th clock pulse.

To receive the address in slave mode, clear the TRS bit to 0 during the time indicated as (a) in figure 15.34. To release the SCL low level that is held by means of the wait function in slave mode, clear the TRS bit to and then dummy-read ICDDR.

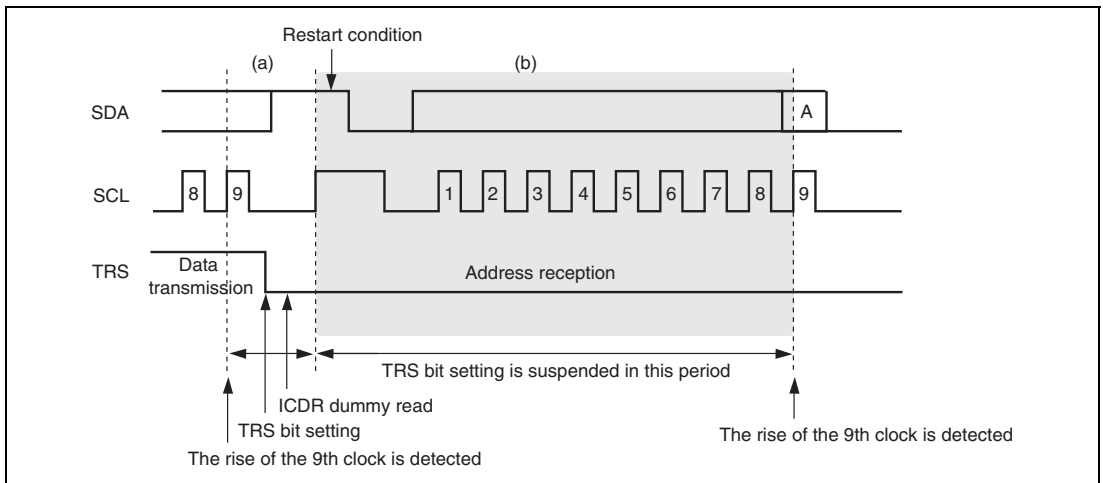

Figure 15.34 TRS Bit Set Timing in Slave Mode

Note: This restriction on usage can be canceled by setting the FNC1 and FNC0 bits to B'11 in ICXR.

13. Note on ICDDR read in transmit mode and ICDDR write in receive mode

When ICDDR is read in transmit mode (TRS = 1) or ICDDR is written to in receive mode (TRS = 0), the SCL pin may not be held low in some cases after transmit/receive operation has been completed, thus inconveniently allowing clock pulses to be output on the SCL bus line before ICDDR is accessed correctly. To access ICDDR correctly, read the ICDDR after setting receive mode or write to the ICDDR after setting transmit mode.

14. Note on ACKE and TRS bits in slave mode

In the I²C bus interface, if 1 is received as the acknowledge bit value (ACKB = 1) in transmit mode (TRS = 1) and then the address is received in slave mode without performing appropriate processing, interrupt handling may start at the rising edge of the 9th clock pulse even when the address does not match. Similarly, if the start condition and address are transmitted from the master device in slave transmit mode (TRS = 1), the ICDRE flag is set, and 1 is received as the acknowledge bit value (ACKB = 1), the IRIC flag may be set thus causing an interrupt source even when the address does not match.

To use the I²C bus interface module in slave mode, be sure to follow the procedures below.

- When having received 1 as the acknowledge bit value for the last transmit data at the end of a series of transmit operation, clear the ACKE bit in ICCR once to initialize the ACKB bit to 0.
- Set receive mode (TRS = 0) before the next start condition is input in slave mode. Complete transmit operation by the procedure shown in figure 15.23, in order to switch from slave transmit mode to slave receive mode.

15. Notes on Arbitration Lost in Master Mode Operation

The I²C bus interface recognizes the data in transmit/receive frame as an address when arbitration is lost in master mode and a transition to slave receive mode is automatically carried out.

When arbitration is lost not in the first frame but in the second frame or subsequent frame, transmit/receive data that is not an address is compared with the value set in the SAR or SARX register as an address. If the receive data matches with the address in the SAR or SARX register, the I²C bus interface erroneously recognizes that the address call has occurred. (See figure 15.35.)

In multi-master mode, a bus conflict could happen. When the I²C bus interface is operated in master mode, check the state of the AL bit in the ICSR register every time after one frame of data has been transmitted or received.

When arbitration is lost during transmitting the second frame or subsequent frame, take avoidance measures.

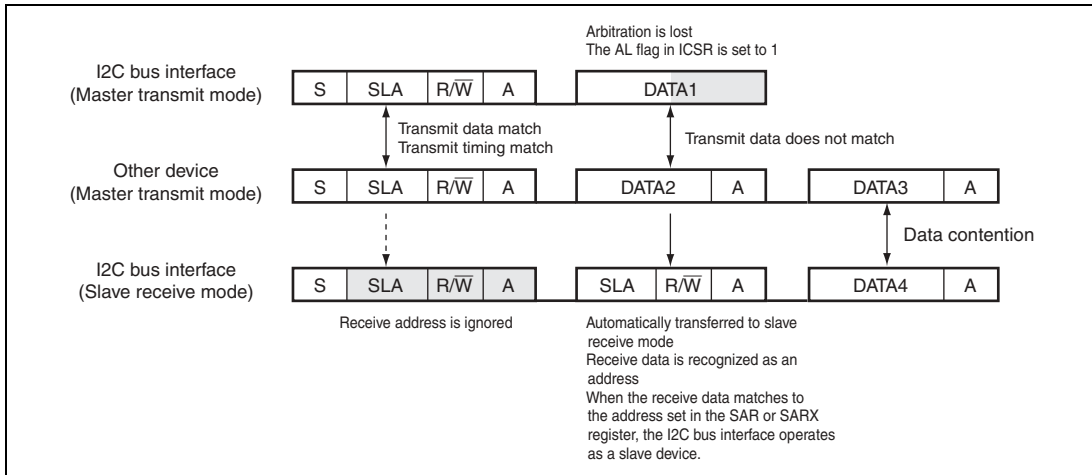

Figure 15.35 Diagram of Erroneous Operation when Arbitration Lost

Though it is prohibited in the normal I²C protocol, the same problem may occur when the MST bit is erroneously set to 1 and a transition to master mode is occurred during data transmission or reception in slave mode.

When the MST bit is set to 1 during data transmission or reception in slave mode, the arbitration decision circuit is enabled and arbitration is lost if conditions are satisfied. In this case, the transmit/receive data which is not an address may be erroneously recognized as an address.

In multi-master mode, pay attention to the setting of the MST bit when a bus conflict may occur. In this case, the MST bit in the ICCR register should be set to 1 according to the order below.

- A. Make sure that the BBSY flag in the ICCR register is 0 and the bus is free before setting the MST bit.
- B. Set the MST bit to 1.
- C. To confirm that the bus was not entered to the busy state while the MST bit is being set, check that the BBSY flag in the ICCR register is 0 immediately after the MST bit has been set.

Note: Above restrictions can be released by setting the bits FNC1 and FNC2 in ICXR to B'11.

Section 16 LPC Interface (LPC)

This LSI has an on-chip LPC interface.

The LPC performs serial transfer of cycle type, address, and data, synchronized with the 33 MHz PCI clock. It uses four signal lines for address/data, and one for host interrupt requests. The LPC interface operates as a slave and supports only I/O read cycle and I/O write cycle transfer.

It is also provided with power-down functions that can control the PCI clock and shut down the LPC interface.

16.1 Features

- Supports LPC interface I/O read cycles and I/O write cycles
Uses four signal lines (LAD3 to LAD0) to transfer the cycle type, address, and data.
Uses three control signals: clock (LCLK), reset ($\overline{\text{LRESET}}$), and frame ($\overline{\text{LFRAME}}$).
- Has three register sets comprising data and status registers
The basic register set comprises three bytes: an input register (IDR), output register (ODR), and status register (STR).
Channels 1 to 3 have fixed I/O addresses of H'0000 to H'FFFF, respectively.
A fast A20 gate function is also provided.
Sixteen bidirectional data register bytes can be manipulated in addition to the basic register set.
- Supports SERIRQ
Host interrupt requests are transferred serially on a single signal line (SERIRQ).
On channel 1, HIRQ1 and HIRQ12 can be generated.
On channels 2 and 3, SMI, HIRQ6, and HIRQ9 to HIRQ11 can be generated.
Operation can be switched between quiet mode and continuous mode.
The $\overline{\text{CLKRUN}}$ signal can be manipulated to restart the PCI clock (LCLK).
- Power-down functions, interrupts, etc.
The LPC module can be shut down by inputting the $\overline{\text{LPCPD}}$ signal.
Three pins, $\overline{\text{PME}}$, $\overline{\text{LSMI}}$, and LSCI, are provided for general input/output.
- Supports version 1.5 of the Intelligent Platform Management Interface (IPMI)
Channel 3 supports the SMIC interface, KCS interface, and BT interface.

Figure 16.1 shows a block diagram of the LPC.

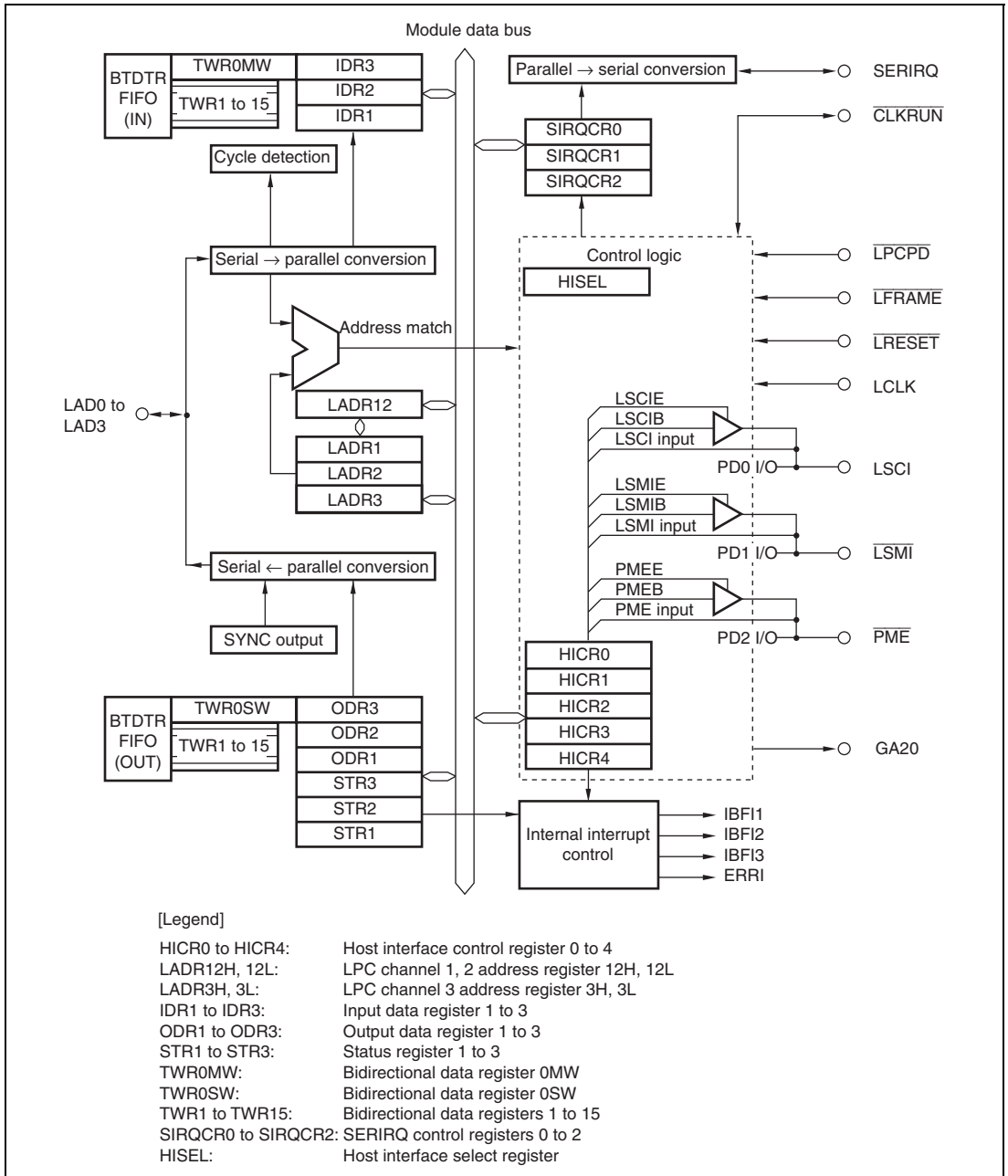

Figure 16.1 Block Diagram of LPC

16.2 Input/Output Pins

Table 16.1 lists the input and output pins of the LPC.

Table 16.1 Pin Configuration

Name	Abbreviation	Port	I/O	Function
LPC address/ data 3 to 0	LAD3 to LAD0	PE3 to PE0	I/O	Serial (4-signal-line) transfer cycle type/address/data signals, synchronized with LCLK
LPC frame	$\overline{\text{LFRAME}}$	PE4	Input* ¹	Transfer cycle start and forced termination signal
LPC reset	$\overline{\text{LRESET}}$	PE5	Input* ¹	LPC interface reset signal
LPC clock	LCLK	PE6	Input	33 MHz PCI clock signal
Serialized interrupt request	SERIRQ	PE7	I/O* ¹	Serialized host interrupt request signal, synchronized with LCLK (SMI, HIRQ1, HIRQ6, HIRQ9 to HIRQ12)
LSCI general output	LSCI	PD0	Output* ^{1,*2}	General output
LSMI general output	$\overline{\text{LSMI}}$	PD1	Output* ^{1,*2}	General output
PME general output	$\overline{\text{PME}}$	PD2	Output* ^{1,*2}	General output
GATE A20	GA20	PD3	Output* ^{1,*2}	A20 gate control signal output
LPC clock run	$\overline{\text{CLKRUN}}$	PD4	I/O* ^{1,*2}	LCLK restart request signal in case of serial host interrupt request
LPC power-down	$\overline{\text{LPCPD}}$	PD5	Input* ¹	LPC module shutdown signal

Notes: 1. Pin state monitoring input is possible in addition to the LPC interface control input/output function.

2. Only 0 can be output. If 1 is output, the pin goes to the high-impedance state, so an external resistor is necessary to pull the signal up to VCC.

16.3 Register Descriptions

The LPC registers are listed in the following. Though this LSI accesses these registers as a slave, some of them can be accessed from the host. For details, see each register description.

- Host interface control register 0 (HICR0)
- Host interface control register 1 (HICR1)
- Host interface control register 2 (HICR2)
- Host interface control register 3 (HICR3)
- Host interface control register 4 (HICR4)
- LPC channel 3 Address register H, L (LADR3H, LADR3L)
- LPC channel 1, 2 address register H, L (LADR12H, LADR12L)
- Input data register 1 (IDR1)
- Input data register 2 (IDR2)
- Input data register 3 (IDR3)
- Output data register 1 (ODR1)
- Output data register 2 (ODR2)
- Output data register 3 (ODR3)
- Bidirectional data registers 0 to 15 (TWR0 to TWR15)
- Status register 1 (STR1)
- Status register 2 (STR2)
- Status register 3 (STR3)
- SERIRQ control register 0 (SIRQCR0)
- SERIRQ control register 1 (SIRQCR1)
- SERIRQ control register 2 (SIRQCR2)
- Host interface select register (HISEL)

SMIC mode:

The following registers are required when SMIC mode is used.

- SMIC flag register (SMICFLG)
- SMIC control status register (SMICCSR)
- SMIC data register (SMICDTR)
- SMIC interrupt register 0 (SMICIR0)
- SMIC interrupt register 1 (SMICIR1)

BT mode:

The following registers are required when BT mode is used.

- BT status register 0 (BTSR0)
- BT status register 1 (BTSR1)
- BT control status register 0 (BTCSR0)
- BT control status register 1 (BTCSR1)
- BT control register (BTCCR)
- BT data buffer (BTDTR)
- BT interrupt mask register (BTIMSR)
- BT FIFO valid size register 0 (BTFVSR0)
- BT FIFO valid size register 1 (BTFVSR1)

16.3.1 Host Interface Control Registers 0 and 1 (HICR0, HICR1)

HICR0 and HICR1 contain control bits that enable or disable LPC interface functions, control bits that determine pin output and the internal state of the LPC interface, and status flags that monitor the internal state of the LPC interface.

HICR0 and HICR1 are initialized to H'00 by a reset or in hardware standby mode.

- HICR0

Bit	Bit Name	Initial Value	R/W		Description
			Slave	Host	
7	LPC3E	0	R/W	—	LPC Enable 3 to 1
6	LPC2E	0	R/W	—	Enables or disables the LPC interface function.
5	LPC1E	0	R/W	—	When the host interface is enabled (at least one of the three bits is set to 1), processing for data transfer between the slave processor and the host processor is performed using pins LAD3 to LAD0, $\overline{\text{LFRAME}}$, $\overline{\text{LRESET}}$, LCLK, SERIRQ, $\overline{\text{CLKRUN}}$, and $\overline{\text{LPCPD}}$.
					<ul style="list-style-type: none"> • LPC3E 0: LPC channel 3 operation is disabled No address (LADR3) matches for IDR3, ODR3, STR3, TWR0 to TWR15, SMIC, KCS, or BT 1: LPC channel 3 operation is enabled
					<ul style="list-style-type: none"> • LPC2E 0: LPC channel 2 operation is disabled No address (LADR2) matches for IDR2, ODR2, or STR2 1: LPC channel 2 operation is enabled
					<ul style="list-style-type: none"> • LPC1E 0: LPC channel 1 operation is disabled No address (LADR1) matches for IDR1, ODR1, or STR1 1: LPC channel 1 operation is enabled

Bit	Bit Name	Initial Value	Slave	Host	Description
4	FGA20E	0	R/W	—	<p>Fast A20 Gate Function Enable</p> <p>Enables or disables the fast A20 gate function. When the fast A20 gate is disabled, the normal A20 gate can be implemented by firmware operation of the PD3 output.</p> <p>When the fast A20 gate function is enabled, the DDR bit for PD3 must not be set to 1.</p> <p>0: Fast A20 gate function disabled</p> <ul style="list-style-type: none"> Other function of the pin is enabled GA20 output internal state is initialized to 1 <p>1: Fast A20 gate function enabled</p> <ul style="list-style-type: none"> GA20 pin output is open-drain (external VCC pull-up resistor required)
3	SDWNE	0	R/W	—	<p>LPC Software Shutdown Enable</p> <p>Controls LPC interface shutdown. For details of the LPC shutdown function, and the scope of initialization by an LPC reset and an LPC shutdown, see section 16.4.6, LPC Interface Shutdown Function (LPCPD).</p> <p>0: Normal state, LPC software shutdown setting enabled</p> <p>[Clearing conditions]</p> <ul style="list-style-type: none"> Writing 0 LPC hardware reset or LPC software reset LPC hardware shutdown release (rising edge of $\overline{\text{LPCPD}}$ signal) <p>1: LPC hardware shutdown state setting enabled</p> <ul style="list-style-type: none"> Hardware shutdown state when $\overline{\text{LPCPD}}$ signal is low <p>[Setting condition]</p> <ul style="list-style-type: none"> Writing 1 after reading SDWNE = 0

Bit	Bit Name	Initial	R/W		Description
		Value	Slave	Host	
2	PMEE	0	R/W	—	<p>PME Output Enable</p> <p>Controls PME output in combination with the PMEB bit in HICR1. $\overline{\text{PME}}$ pin output is open-drain, and an external pull-up resistor is needed to pull the output up to VCC</p> <p>When the PME output function is used, the DDR bit for PD2 must not be set to 1.</p> <p>PMEE PMEB</p> <p>0 * : PME output disabled, other function of pin is enabled</p> <p>1 0 : PME output enabled, $\overline{\text{PME}}$ pin output goes to 0 level</p> <p>1 1 : PME output enabled, $\overline{\text{PME}}$ pin output is high-impedance</p>
1	LSMIE	0	R/W	—	<p>LSMI Output Enable</p> <p>Controls LSMI output in combination with the LSMIB bit in HICR1. $\overline{\text{LSMI}}$ pin output is open-drain, and an external pull-up resistor is needed to pull the output up to VCC</p> <p>When the LSMI output function is used, the DDR bit for PD1 must not be set to 1.</p> <p>LSMIE LSMIB</p> <p>0 * : LSMI output disabled, other function of pin is enabled</p> <p>1 0 : LSMI output enabled, $\overline{\text{LSMI}}$ pin output goes to 0 level</p> <p>1 1 : LSMI output enabled, $\overline{\text{LSMI}}$ pin output is high-impedance</p>
0	LSCIE	0	R/W	—	<p>LSCI Output Enable</p> <p>Controls LSCI output in combination with the LSCIB bit in HICR1. LSCI pin output is open-drain, and an external pull-up resistor is needed to pull the output up to VCC</p> <p>When the LSCI output function is used, the DDR bit for PD0 must not be set to 1.</p> <p>LSCIE LSCIB</p> <p>0 * : LSCI output disabled, other function of pin is enabled</p> <p>1 0 : LSCI output enabled, LSCI pin output goes to 0 level</p> <p>1 1 : LSCI output enabled, LSCI pin output is high-impedance</p>

Note: * Don't care

- HICR1

Bit	Bit Name	Initial Value	R/W		Description
			Slave	Host	
7	LPCBSY	0	R	—	<p>LPC Busy</p> <p>Indicates that the LPC interface is processing a transfer cycle.</p> <p>0: LPC interface is in transfer cycle wait state</p> <ul style="list-style-type: none"> • Bus idle, or transfer cycle not subject to processing is in progress • Cycle type or address indeterminate during transfer cycle <p>[Clearing conditions]</p> <ul style="list-style-type: none"> • LPC hardware reset or LPC software reset • LPC hardware shutdown or LPC software shutdown • Forced termination (abort) of transfer cycle subject to processing • Normal termination of transfer cycle subject to processing <p>1: LPC interface is performing transfer cycle processing</p> <p>[Setting condition]</p> <ul style="list-style-type: none"> • Match of cycle type and address
6	CLKREQ	0	R	—	<p>LCLK Request</p> <p>Indicates that the LPC interface's SERIRQ output is requesting a restart of LCLK.</p> <p>0: No LCLK restart request</p> <p>[Clearing conditions]</p> <ul style="list-style-type: none"> • LPC hardware reset or LPC software reset • LPC hardware shutdown or LPC software shutdown • SERIRQ is set to continuous mode • There are no further interrupts for transfer to the host in quiet mode <p>1: LCLK restart request issued</p> <p>[Setting condition]</p> <ul style="list-style-type: none"> • In quiet mode, SERIRQ interrupt output becomes necessary while LCLK is stopped

Bit	Bit Name	Initial Value	Slave	Host	Description
5	IRQBSY	0	R	—	<p>SERIRQ Busy</p> <p>Indicates that the LPC interface's SERIRQ signal is engaged in transfer processing.</p> <p>0: SERIRQ transfer frame wait state</p> <p>[Clearing conditions]</p> <ul style="list-style-type: none"> LPC hardware reset or LPC software reset LPC hardware shutdown or LPC software shutdown End of SERIRQ transfer frame <p>1: SERIRQ transfer processing in progress</p> <p>[Setting condition]</p> <ul style="list-style-type: none"> Start of SERIRQ transfer frame
4	LRSTB	0	R/W	—	<p>LPC Software Reset Bit</p> <p>Resets the LPC interface. For the scope of initialization by an LPC reset, see section 16.4.6, LPC Interface Shutdown Function (LPCPD).</p> <p>0: Normal state</p> <p>[Clearing conditions]</p> <ul style="list-style-type: none"> Writing 0 LPC hardware reset <p>1: LPC software reset state</p> <p>[Setting condition]</p> <ul style="list-style-type: none"> Writing 1 after reading LRSTB = 0

R/W

Bit	Bit Name	Initial Value	Slave	Host	Description
3	SDWNB	0	R/W	—	<p>LPC Software Shutdown Bit</p> <p>Controls LPC interface shutdown. For details of the LPC shutdown function, and the scope of initialization by an LPC reset and an LPC shutdown, see section 16.4.6, LPC Interface Shutdown Function (LPCPD).</p> <p>0: Normal state [Clearing conditions]</p> <ul style="list-style-type: none"> • Writing 0 • LPC hardware reset or LPC software reset • LPC hardware shutdown (falling edge of $\overline{\text{LPCPD}}$ signal when $\text{SDWNE} = 1$) • LPC hardware shutdown release (rising edge of $\overline{\text{LPCPD}}$ signal when $\text{SDWNE} = 0$) <p>1: LPC software shutdown state [Setting condition]</p> <ul style="list-style-type: none"> • Writing 1 after reading $\text{SDWNB} = 0$
2	PMEB	0	R/W	—	<p>PME Output Bit</p> <p>Controls PME output by the combination with the PMEE bit.</p> <p>For details, see the PMEE bit in HICR0.</p>
1	LSMIB	0	R/W	—	<p>LSMI Output Bit</p> <p>Controls LSMI output by the combination with the LSMIE bit.</p> <p>For details, see the LSMIE bit in HICR0.</p>
0	LSCIB	0	R/W	—	<p>LSCI Output Bit</p> <p>Controls LSCI output by the combination with the LSCIE bit.</p> <p>For details, see the LSCIE bit in HICR0.</p>

16.3.2 Host Interface Control Registers 2 and 3 (HICR2, HICR3)

The bits 6 to 0 in HICR2 control interrupts from the LPC interface module to the slave processor (this LSI). HICR3 and the bit 7 of HICR2 monitor the LPC interface pin states.

Bits 6 to 0 in HICR2 are initialized to H'00 by a reset or in hardware standby mode. The states of the other bits are determined by the pin states.

The pin states can be monitored regardless of the LPC interface operating state or the operating state of the functions that use pin multiplexing.

- HICR2

Bit	Bit Name	Initial Value	R/W		Description
			Slave	Host	
7	GA20	Undefined	R	—	GA20 Pin Monitor
6	LRST	0	R/(W)*	—	<p>LPC Reset Interrupt Flag</p> <p>Interrupt flag that generates an ERRI interrupt when an LPC hardware reset occurs.</p> <p>0: [Clearing condition]</p> <ul style="list-style-type: none"> • Writing 0 after reading LRST = 1 <p>1: [Setting condition]</p> <ul style="list-style-type: none"> • $\overline{\text{LRESET}}$ pin falling edge detection
5	SDWN	0	R/(W)*	—	<p>LPC Shutdown Interrupt Flag</p> <p>Interrupt flag that generates an ERRI interrupt when an LPC hardware shutdown request is generated.</p> <p>0: [Clearing conditions]</p> <ul style="list-style-type: none"> • Writing 0 after reading SDWN = 1 • LPC hardware reset • LPC software reset <p>1: [Setting condition]</p> <ul style="list-style-type: none"> • $\overline{\text{LPCPD}}$ pin falling edge detection

Bit	Bit Name	Initial Value	Slave	Host	Description
4	ABRT	0	R/(W)*	—	<p>LPC Abort Interrupt Flag</p> <p>Interrupt flag that generates an ERRRI interrupt when a forced termination (abort) of an LPC transfer cycle occurs.</p> <p>0: [Clearing conditions]</p> <ul style="list-style-type: none"> • Writing 0 after reading ABRT = 1 • LPC hardware reset • LPC software reset • LPC hardware shutdown • LPC software shutdown <p>1: [Setting condition]</p> <ul style="list-style-type: none"> • $\overline{\text{LFRAME}}$ pin falling edge detection during LPC transfer cycle
3	IBFIE3	0	R/W	—	<p>IBFI3 Interrupt Enable</p> <p>Enables or disables IBFI3 interrupt to the slave processor (this LSI).</p> <p>0: Input data register IDR3 and TWR receive completed interrupt requests and SMIC mode and BT mode interrupt requests are disabled</p> <p>1: [When TWRE in LADR3 = 0]</p> <p>Input data register IDR3 receive completed interrupt request and SMIC mode and BT mode interrupt requests are enabled</p> <p>[When TWRE in LADR3 = 1]</p> <p>Input data register IDR3 and TWR receive completed interrupt requests and SMIC mode and BT mode interrupt requests are enabled</p>
2	IBFIE2	0	R/W	—	<p>IDR2 Receive Completion Interrupt Enable</p> <p>Enables or disables IBFI2 interrupt to the slave processor (this LSI).</p> <p>0: Input data register IDR2 receive completed interrupt requests disabled</p> <p>1: Input data register IDR2 receive completed interrupt requests enabled</p>

R/W

Bit	Bit Name	Initial Value	Slave	Host	Description
1	IBFIE1	0	R/W	—	IDR1 Receive Completion Interrupt Enable Enables or disables IBF11 interrupt to the slave processor (this LSI). 0: Input data register IDR1 receive completed interrupt requests disabled 1: Input data register IDR1 receive completed interrupt requests enabled
0	ERRIE	0	R/W	—	Error Interrupt Enable Enables or disables ERR1 interrupt to the slave processor (this LSI). 0: Error interrupt requests disabled 1: Error interrupt requests enabled

Note: * Only 0 can be written to clear bits 6 to 4.

- HICR3

R/W

Bit	Bit Name	Initial Value	Slave	Host	Description
7	LFRAME	Undefined	R	—	$\overline{\text{LFRAME}}$ Pin Monitor
6	CLKRUN	Undefined	R	—	$\overline{\text{CLKRUN}}$ Pin Monitor
5	SERIRQ	Undefined	R	—	$\overline{\text{SERIRQ}}$ Pin Monitor
4	LRESET	Undefined	R	—	$\overline{\text{LRESET}}$ Pin Monitor
3	LPCPD	Undefined	R	—	$\overline{\text{LPCPD}}$ Pin Monitor
2	PME	Undefined	R	—	$\overline{\text{PME}}$ Pin Monitor
1	LSMI	Undefined	R	—	$\overline{\text{LSMI}}$ Pin Monitor
0	LSCI	Undefined	R	—	$\overline{\text{LSCI}}$ Pin Monitor

16.3.3 Host Interface Control Register 4 (HICR4)

HICR4 controls the selection of access channel when setting addresses for LPC channels 1 and 2, and the operation of KCS, SMIC, and BT interfaces included in channel 3.

Bit	Bit Name	Initial Value	R/W		Description
			Slave	Host	
7	LADR12SEL	0	R/W	—	Switches the access channel of LADR12H, LADR12L. 0: LADR1 is selected 1: LADR2 is selected
6 to 4	—	All 0	R/W	—	Reserved The initial value should not be changed.
3	SWENBL	0	R/W	—	In BT mode, H'5 (short wait) or H'6 (long wait) is returned to the host in the synchronized return cycle from slave, thus can make the host wait. 0: Short wait is issued 1: Long wait is issued
2	KCSENBL	0	R/W	—	Enables or disables the use of the KCS interface included in channel 3. When the LPC3E bit in HICR0 is 0, this bit is valid. 0: KCS interface operation is disabled No address (LADR3) matches for IDR3, ODR3, or STR3 in KCS mode 1: KCS interface operation is enabled
1	SMICENBL	0	R/W	—	Enables or disables the use of the SMIC interface included in channel 3. When the LPC3E bit in HICR0 is 0, this bit is valid. 0: SMIC interface operation is disabled No address (LADR3) matches for SMICFLG, SSMICCSR, or SMICDTR 1: SMIC interface operation is enabled
0	BTENBL	0	R/W	—	Enables or disables the use of the BT interface included in channel 3. When the LPC3E bit in HICR0 is 0, this bit is valid. 0: BT interface operation is disabled No address (LADR3) matches for BTIMSR, BTCR, or BTDTR 1: BT interface operation is enabled

16.3.4 LPC Channel 3 Address Register H, L (LADR3H, LADR3L)

LADR3 comprises two 8-bit readable/writable registers that perform LPC channel 3 host address setting and control the operation of the bidirectional data registers. The contents of the address field in LADR3 must not be changed while channel 3 is operating (while LPC3E is set to 1).

- LADR3H

Bit	Bit Name	Initial Value	R/W		Description
			Slave	Host	
7	Bit 15	All 0	R/W	—	Channel 3 Address Bits 15 to 8
6	Bit 14				The host address of LPC channel 3 is set.
5	Bit 13				
4	Bit 12				
3	Bit 11				
2	Bit 10				
1	Bit 9				
0	Bit 8				

- LADR3L

Bit	Bit Name	Initial Value	R/W		Description
			Slave	Host	
7	Bit 7	All 0	R/W	—	Channel 3 Address Bits 7 to 3
6	Bit 6				The host address of LPC channel 3 is set.
5	Bit 5				
4	Bit 4				
3	Bit 3				
2	—	0	R/W	—	Reserved The initial value should not be changed.
1	Bit 1	0	R/W	—	Channel 3 Address Bit 1 The host address of LPC channel 3 is set.
0	TWRE	0	R/W	—	Bidirectional data Register Enable Enables or disables bidirectional data register operation. Clear this bit to 0 in KCS mode. 0: TWR operation is disabled TWR-related address (LADR3) match does not occur. 1: TWR operation is enabled

When $LPC3E = 1$, an I/O address received in an LPC I/O cycle is compared with the contents of LADR3. When determining an IDR3, ODR3, or STR3 address match, bit 0 in LADR3 is regarded as 0, and the value of bit 2 is ignored. When determining a TWR0 to TWR15 address match, bit 4 of LADR3 is inverted, and the values of bits 3 to 0 are ignored. When determining an IDR3, ODR3, or STR3 address match in KCS mode, an SMICFLG, SMICCSR, SMICDTR address match in SMIC mode, and a BTDTR, BTCR, BTIMSR address match in BT mode, the values of bits 3 to 0 are ignored.

Register selection according to the bits ignored in address match determination is as shown in the following table.

I/O Address						Transfer Cycle	Host Register Selection
Bits 15 to5	Bit 4	Bit 3	Bit 2	Bit 1	Bit 0		
Bits 15 to5	Bit 4	Bit 3	0	Bit 1	0	I/O write	IDR3 write, $C/\overline{D}3 \leftarrow 0$
Bits 15 to5	Bit 4	Bit 3	1	Bit 1	0	I/O write	IDR3 write, $C/\overline{D}3 \leftarrow 1$
Bits 15 to5	Bit 4	Bit 3	0	Bit 1	0	I/O read	ODR3 read
Bits 15 to5	Bit 4	Bit 3	1	Bit 1	0	I/O read	STR3 read
Bits 15 to5	$\overline{\text{Bit 4}}$	0	0	0	0	I/O write	TWR0MW write
Bits 15 to5	$\overline{\text{Bit 4}}$	0	0	0	1	I/O write	TWR1 to TWR15 write
		•	•	•	•		
		•	•	•	•		
		•	•	•	•		
		1	1	1	1		
Bits 15 to5	$\overline{\text{Bit 4}}$	0	0	0	0	I/O read	TWR0SW read
Bits 15 to5	$\overline{\text{Bit 4}}$	0	0	0	1	I/O read	TWR1 to TWR15 read
		•	•	•	•		
		•	•	•	•		
		•	•	•	•		
		1	1	1	1		

- KCS mode

I/O Address						Transfer Cycle	Host Register Selection
Bits 15 to5	Bit 4	Bit 3	Bit 2	Bit 1	Bit 0		
Bits 15 to5	Bit 4	0	0	1	0	I/O write	IDR3 write, $C/\bar{D}3 \leftarrow 0$
Bits 15 to5	Bit 4	0	0	1	1	I/O write	IDR3 write, $C/\bar{D}3 \leftarrow 1$
Bits 15 to5	Bit 4	0	0	1	0	I/O read	ODR3 read
Bits 15 to5	Bit 4	0	0	1	1	I/O read	STR3 read

- BT mode

I/O Address						Transfer Cycle	Host Register Selection
Bits 15 to5	Bit 4	Bit 3	Bit 2	Bit 1	Bit 0		
Bits 15 to5	Bit 4	0	1	0	0	I/O write	BTCR write
Bits 15 to5	Bit 4	0	1	0	1	I/O write	BTDTR write
Bits 15 to5	Bit 4	0	1	1	0	I/O write	BTIMSR write
Bits 15 to5	Bit 4	0	1	0	0	I/O read	BTCR read
Bits 15 to5	Bit 4	0	1	0	1	I/O read	BTDTR read
Bits 15 to5	Bit 4	0	1	1	0	I/O read	BTIMSR read

- SMIC mode

I/O Address						Transfer Cycle	Host Register Selection
Bits 15 to5	Bit 4	Bit 3	Bit 2	Bit 1	Bit 0		
Bits 15 to5	Bit 4	1	0	0	1	I/O write	SMICDTR write
Bits 15 to5	Bit 4	1	0	1	0	I/O write	SMICCSR write
Bits 15 to5	Bit 4	1	0	1	1	I/O write	SMICFLG write
Bits 15 to5	Bit 4	1	0	0	1	I/O read	SMICDTR read
Bits 15 to5	Bit 4	1	0	1	0	I/O read	SMICCSR read
Bits 15 to5	Bit 4	1	0	1	1	I/O read	SMICFLG read

- Notes on determining address match

The IDR3/ODR3/STR3 addresses depend on mode.

LPC3 E	SELS TR3	KCSE NBL	SMIC TWRE	BTEN ENBL	BTEN BL	Accessible Mode	IDR3/ODR3/STR3 Host Addresses	STR3:TWR Related Bit
0	—*	—*	—*	—*	—*	Channel 3 access disabled	Access disabled	Access disabled
1	0	0	0	0	0	Normal mode	LADR3+0/+4	TWR flag bit
1	0	0	0	0	1	BT mode	Access disabled	Access disabled
1	0	0	0	1	0	SMIC mode	Access disabled	Access disabled
1	0	0	0	1	1	SMIC/BT mode	Access disabled	Access disabled
1	0	0	1	0	0	TWR mode	LADR3+0/+4	TWR flag bit
1	0	0	1	0	1	TWR/BT mode	LADR3+2/+3	TWR flag bit
1	0	0	1	1	0	TWR/SMIC mode	LADR3+2/+3	TWR flag bit
1	0	0	1	1	1	TWR/SMIC/BT mode	LADR3+2/+3	TWR flag bit
1	0	1	0	0	0	KCS mode	LADR3+2/+3	TWR flag bit
1	0	1	0	0	1	KCS/BT mode	LADR3+2/+3	TWR flag bit
1	0	1	0	1	0	KCS/SMIC mode	LADR3+2/+3	TWR flag bit
1	0	1	0	1	1	KCS/SMIC/BT mode	LADR3+2/+3	TWR flag bit
1	1	0	0	0	0	Normal mode	LADR3+0/+4	User definition bit
1	1	0	0	0	1	BT mode	Access disabled	Access disabled
1	1	0	0	1	0	SMIC mode	Access disabled	Access disabled
1	1	0	0	1	1	SMIC/BT mode	Access disabled	Access disabled
1	1	0	1	0	0	TWR mode	LADR3+0/+4	TWR flag bit
1	1	0	1	0	1	TWR/BT mode	LADR3+2/+3	TWR flag bit
1	1	0	1	1	0	TWR/SMIC mode	LADR3+2/+3	TWR flag bit
1	1	0	1	1	1	TWR/SMIC/BT mode	LADR3+2/+3	TWR flag bit
1	1	1	0	0	0	KCS mode	LADR3+2/+3	User definition bit
1	1	1	0	0	1	KCS/BT mode	LADR3+2/+3	User definition bit
1	1	1	0	1	0	KCS/SMIC mode	LADR3+2/+3	User definition bit
1	1	1	0	1	1	KCS/SMIC/BT mode	LADR3+2/+3	User definition bit
1	—*	1	1	—*	—*	Setting prohibited	Setting prohibited	Setting prohibited

Note: * Don't care

16.3.5 LPC Channel 1, 2 Address Register H, L (LADR12H, LADR12L)

LADR12H and LADR12L are temporary registers for accessing internal registers LADR1H, LADR1L, LADR2H, and LADR2L.

When the LADR12SEL bit in HICR4 is 0, LPC channel 1 host addresses (LADR1H, LADR1L) are set through LADR12. The contents of the address field in LADR1 must not be changed while channel 1 is operating (while LPC1E is set to 1).

When the LADR12SEL bit is 1, LPC channel 2 host addresses (LADR2H, LADR2L) are set through LADR12. The contents of the address field in LADR2 must not be changed while channel 2 is operating (while LPC2E is set to 1).

Table 16.2 shows the initial value of each register. Table 16.3 shows the host register selection in address match determination. Table 16.4 shows the slave selection internal registers in slave (this LSI) access.

Table 16.2 LADR1, LADR2 Initial Values

Register Name	Initial Value	Description
LADR1	H'0060	I/O address of channel 1
LADR2	H'0062	I/O address of channel 2

Table 16.3 Host Register Selection

Bits 15 to 3	I/O Address			Transfer Cycle	Host Register Selection
	Bit 2	Bit 1	Bit 0		
LADR1 (bits 15 to 3)	0	LADR1 (bit 1)	LADR1 (bit 0)	I/O write	IDR1 write (data), C/D1 ← 0
LADR1 (bits 15 to 3)	1	LADR1 (bit 1)	LADR1 (bit 0)	I/O write	IDR1 write (command), C/D1 ← 1
LADR1 (bits 15 to 3)	0	LADR1 (bit 1)	LADR1 (bit 0)	I/O read	ORD1 read
LADR1 (bits 15 to 3)	1	LADR1 (bit 1)	LADR1 (bit 0)	I/O read	STR1 read
LADR2 (bits 15 to 3)	0	LADR2 (bit 1)	LADR2 (bit 0)	I/O write	IDR2 write (data), C/D2 ← 0
LADR2 (bits 15 to 3)	1	LADR2 (bit 1)	LADR2 (bit 0)	I/O write	IDR2 write (command), C/D2 ← 1
LADR2 (bits 15 to 3)	0	LADR2 (bit 1)	LADR2 (bit 0)	I/O read	ODR2 read
LADR2 (bits 15 to 3)	1	LADR2 (bit 1)	LADR2 (bit 0)	I/O read	STR2 read

Table 16.4 Slave Selection Internal Registers

Slave (R/W)	Bus Width (B/W)	LADR12SEL	LADR12		Internal Register	
R/W	B	0	LADR12H		LADR1H	
R/W	B	1	LADR12H		LADR2H	
R/W	B	0	LADR12L		LADR1L	
R/W	B	1	LADR12L		LADR2L	
R/W	W	0	LADR12H	LADR12L	LADR1H	LADR1L
R/W	W	1	LADR12H	LADR12L	LADR2H	LADR2L

16.3.6 Input Data Registers 1 to 3 (IDR1 to IDR3)

The IDR registers are 8-bit read-only registers to the slave processor (this LSI), and 8-bit write-only registers to the host processor. The registers selected from the host according to the I/O address are described in the following sections: for information on IDR1 and IDR2 selection, see section 16.3.5, LPC Channel 1, 2 Address Register H, L (LADR12H, LADR12L), and for information on IDR3 selection, see section 16.3.4, LPC Channel 3 Address Register H, L (LADR3H, LADR3L). Data transferred in an LPC I/O write cycle is written to the selected register. The state of bit 2 of the I/O address is latched into the $\overline{C/D}$ bit in STR, to indicate whether the written information is a command or data.

The initial values of the IDR registers are undefined.

16.3.7 Output Data Registers 0 to 3 (ODR1 to ODR3)

The ODR registers are 8-bit readable/writable registers to the slave processor (this LSI), and 8-bit read-only registers to the host processor. The registers selected from the host according to the I/O address are described in the following sections: for information on ODR1 and ODR2 selection, see section 16.3.5, LPC Channel 1, 2 Address Register H, L (LADR12H, LADR12L), and for information on ODR3 selection, see section 16.3.4, LPC Channel 3 Address Register H, L (LADR3H, LADR3L). In an LPC I/O read cycle, the data in the selected register is transferred to the host.

The initial values of the ODR registers are undefined.

16.3.8 Bidirectional Data Registers 0 to 15 (TWR0 to TWR15)

TWR0 to TWR15 are sixteen 8-bit readable/writable registers to both the slave processor (this LSI) and the host processor. In TWR0, however, two registers (TWR0MW and TWR0SW) are allocated to the same address for both the host address and the slave address. TWR0MW is a write-only register to the host processor, and a read-only register to the slave processor, while TWR0SW is a write-only register to the slave processor and a read-only register to the host processor. When the host and slave processors begin a write, after the respective TWR0 registers have been written to, access right arbitration for simultaneous access is performed by checking the status flags to see if those writes were valid. For the registers selected from the host according to the I/O address, see section 16.3.4, LPC Channel 3 Address Register H, L (LADR3H, LADR3L).

Data transferred in an LPC I/O write cycle is written to the selected register; in an LPC I/O read cycle, the data in the selected register is transferred to the host.

The initial values of TWR0 to TWR15 are undefined.

16.3.9 Status Registers 1 to 3 (STR1 to STR3)

The STR registers are 8-bit registers that indicate status information during LPC interface processing. Bits 3, 1, and 0 in STR1 to STR3 are read-only bits to both the host processor and the slave processor (this LSI). However, 0 only can be written from the slave processor (this LSI) to bit 0 in STR1 to STR3, and bits 6 and 4 in STR3, in order to clear the flags to 0. The functions for bits 7 to 4 in STR3 differ according to the settings of bit SELSTR3 in HISEL and the TWRE bit in LADR3L. For details, see section 16.3.13, Host Interface Select Register (HISEL). The registers selected from the host processor according to the I/O address are described in the following sections. For information on STR1 and STR2 selection, see section 16.3.5, LPC Channel 1,2 Address Register H, L (LADR12H, LADR12L), and information on STR3 selection, see section 16.3.4, LPC Channel 3 Address Register H, L (LADR3H, LADR3L). In an LPC I/O read cycle, the data in the selected register is transferred to the host processor.

The STR registers are initialized to H'00 by a reset or in hardware standby mode.

- STR1

Bit	Bit Name	Initial Value	R/W		Description
			Slave	Host	
7	DBU17	All 0	R/W	R	Defined by User
6	DBU16				The user can use these bits as necessary.
5	DBU15				
4	DBU14				
3	C/D $\bar{1}$	0	R	R	Command/Data When the host processor writes to an IDR1 register, bit 2 of the I/O address is written into this bit to indicate whether IDR1 contains data or a command. 0: Content of input data register (IDR1) is data 1: Content of input data register (IDR1) is a command
2	DBU12	0	R/W	R	Defined by User The user can use this bit as necessary.

R/W

Bit	Bit Name	Initial Value	Slave	Host	Description
1	IBF1	0	R	R	<p>Input Data Register Full</p> <p>Indicates whether or not there is receive data in IDR1. This bit is an internal interrupt source to the slave processor (this LSI). The IBF1 flag setting and clearing conditions are different when the fast A20 gate is used. For details see table 16.7.</p> <p>0: There is not receive data in IDR1 [Clearing condition]</p> <p>When the slave processor reads IDR</p> <p>1: There is receive data in IDR1 [Setting condition]</p> <p>When the host processor writes to IDR using I/O write cycle</p>
0	OBF1	0	R/(W)*	R	<p>Output Data Register Full</p> <p>Indicates whether or not there is transmit data in ODR1.</p> <p>0: There is not transmit data in ODR1 [Clearing condition]</p> <p>When the host processor reads ODR1 using I/O read cycle, or the slave processor writes 0 to the OBF1 bit</p> <p>1: There is transmit data in ODR1 [Setting condition]</p> <p>When the slave processor writes to ODR1</p>

Note: * Only 0 can be written to clear the flag.

- STR2

Bit	Bit Name	Initial Value	R/W		Description
			Slave	Host	
7	DBU27	All 0	R/W	R	Defined by User
6	DBU26				The user can use these bits as necessary.
5	DBU25				
4	DBU24				
3	C/D $\bar{2}$	0	R	R	
2	DBU22	0	R/W	R	Defined by User The user can use this bit as necessary.
1	IBF2	0	R	R	Input Data Register Full Indicates whether or not there is receive data in IDR2. This bit is an internal interrupt source to the slave processor (this LSI). 0: There is not receive data in IDR2 [Clearing condition] When the slave processor reads IDR2 1: There is receive data in IDR2 [Setting condition] When the host processor writes to IDR2 using I/O write cycle
0	OBF2	0	R/(W) *	R	Output Data Register Full Indicates whether or not there is transmit data in ODR2. 0: There is not transmit data in ODR2 [Clearing condition] When the host processor reads ODR2 using I/O read cycle, or the slave processor writes 0 to the OBF2 bit 1: There is transmit data in ODR2 [Setting condition] When the slave processor writes to ODR2

Note: * Only 0 can be written to clear the flag.

- STR3

(When TWRE = 1 or SELSTR3 = 0)

Bit	Bit Name	Initial Value	R/W		Description
			Slave	Host	
7	IBF3B	0	R	R	<p>Bidirectional Data Register Input Data Full</p> <p>Indicates whether or not there is receive data in TWR0 to TWR15. This is an internal interrupt source to the slave processor (this LSI).</p> <p>0: There is not receive data in TWR15 [Clearing condition]</p> <p>When the slave processor reads TWR15</p> <p>1: There is receive data in TWR0 to TWR15 [Setting condition]</p> <p>When the host processor writes to TWR15 using I/O write cycle</p>
6	OBF3B	0	R/(W)*	R	<p>Bidirectional Data Register Output Data Full</p> <p>Indicates whether or not there is transmit data in TWR0 to TWR15.</p> <p>0: There is not transmit data in TWR15 [Clearing condition]</p> <p>When the host processor reads TWR15 using I/O read cycle, or the slave processor writes 0 to the OBF3B bit</p> <p>1: There is transmit data in TWR0 to TWR15 [Setting condition]</p> <p>When the slave processor writes to TWR15</p>
5	MWMF	0	R	R	<p>Master Write Mode Flag</p> <p>Indicates that master write mode is entered by writing to TWR0 from the host processor.</p> <p>0: [Clearing condition]</p> <p>When the slave processor reads TWR15</p> <p>1: [Setting condition]</p> <p>When the host processor writes to TWR0 using I/O write cycle while SWMF = 0</p>

R/W

Bit	Bit Name	Initial Value	Slave	Host	Description
4	SWMF	0	R/(W)*	R	<p>Slave Write Mode Flag</p> <p>Indicates that slave write mode is entered by writing to TWR0 from the slave processor (this LSI). In the event of simultaneous writes by the master and the slave, the master write has priority.</p> <p>0: [Clearing condition]</p> <p>When the host processor reads TWR15 using I/O read cycle, or the slave processor writes 0 to the SWMF bit</p> <p>1: [Setting condition]</p> <p>When the slave processor writes to TWR0 while MWMF = 0</p>
3	C/D $\bar{3}$	0	R	R	<p>Command/Data</p> <p>When the host processor writes to an IDR3 register, bit 2 of the I/O address is written into this bit to indicate whether IDR3 contains data or a command.</p> <p>0: Content of input data register (IDR3) is data</p> <p>1: Content of input data register (IDR3) is a command</p>
2	DBU32	0	R/W	R	<p>Defined by User</p> <p>The user can use this bit as necessary.</p>
1	IBF3A	0	R	R	<p>Input Data Register Full</p> <p>Indicates whether or not there is receive data in IDR3. This is an internal interrupt source to the slave processor (this LSI).</p> <p>0: There is not receive data in IDR3</p> <p>[Clearing condition]</p> <p>When the slave processor reads IDR3</p> <p>1: There is receive data in IDR3</p> <p>[Setting condition]</p> <p>When the host processor writes to IDR3 using I/O write cycle</p>

R/W

Bit	Bit Name	Initial Value	Slave	Host	Description
0	OBF3A	0	R/(W)*	R	Output Data Register Full Indicates whether or not there is transmit data in ODR3. 0: There is not transmit data in ODR3 [Clearing condition] When the host processor reads ODR3 using I/O read cycle, or the slave processor writes 0 to the OBF3A bit 1: There is transmit data in ODR3 [Setting condition] When the slave processor writes to ODR3

Note: * Only 0 can be written to clear the flag.

- STR3

(When TWRE = 0 and SELSTR3 = 1)

R/W

Bit	Bit Name	Initial Value	Slave	Host	Description
7	DBU37	All 0	R/W	R	Defined by User
6	DBU36				The user can use these bits as necessary.
5	DBU35				
4	DBU34				
3	C/D $\bar{3}$	0	R	R	Command/Data When the host processor writes to an IDR3 register, bit 2 of the I/O address is written into this bit to indicate whether IDR3 contains data or a command. 0: Content of input data register (IDR3) is data 1: Content of input data register (IDR3) is a command
2	DBU32	0	R/W	R	Defined by User The user can use this bit as necessary.

Bit	Bit Name	Initial Value	Slave	Host	Description
1	IBF3A	0	R	R	<p>Input Data Register Full</p> <p>Indicates whether or not there is receive data in IDR3. This bit is an internal interrupt source to the slave processor (this LSI).</p> <p>0: There is not receive data in IDR3 [Clearing condition]</p> <p>When the slave processor reads IDR3</p> <p>1: There is receive data in IDR3 [Setting condition]</p> <p>When the host processor writes to IDR3 using I/O write cycle</p>
0	OBF3A	0	R/(W)*	R	<p>Output Data Register Full</p> <p>Indicates whether or not there is transmit data in ODR3.</p> <p>0: There is not receive data in ODR3 [Clearing condition]</p> <p>When the host processor reads ODR3 using I/O read cycle, or the slave processor writes 0 to the OBF3A bit</p> <p>1: There is receive data in ODR3 [Setting condition]</p> <p>When the slave processor writes to ODR3</p>

Note: * Only 0 can be written to clear the flag.

16.3.10 SERIRQ Control Register 0 (SIRQCR0)

The SIRQCR0 register contains status bits that indicate the SERIRQ operating mode and status bits that specify SERIRQ0 interrupt sources.

The SIRQCR0 register is initialized to H'00 by a reset or in hardware standby mode.

Bit	Bit Name	Initial Value	R/W		Description
			Slave	Host	
7	Q/C	0	R	—	<p>Quiet/Continuous Mode Flag</p> <p>Indicates the mode specified by the host at the end of an SERIRQ transfer cycle (stop frame).</p> <p>0: Continuous mode [Clearing conditions]</p> <ul style="list-style-type: none"> LPC hardware reset, LPC software reset Specification by the stop frame of the SERIRQ transfer cycle <p>1: Quiet mode [Setting condition]</p> <ul style="list-style-type: none"> Specification by the stop frame of the SERIRQ transfer cycle
6	SELREQ	0	R/W	—	<p>Start Frame Initiation Request Select</p> <p>Specifies the condition of start frame activation when the host interrupt request is cleared in quiet mode.</p> <p>0: When all host interrupt requests are cleared in quiet mode, start frame initiation is requested</p> <p>1: When at least one host interrupt request is cleared in quiet mode, start frame initiation is requested</p>
5	IEDIR	0	R/W	—	<p>Interrupt Enable Direct Mode</p> <p>Specifies whether LPC channel 2 SERIRQ interrupt source (SMI, HIRQ6, HIRQ9 to HIRQ11) generation is conditional upon OBF, or is controlled only by the host interrupt enable bit.</p> <p>0: Host interrupt is requested when host interrupt enable bit and corresponding OBF are both set to 1</p> <p>1: Host interrupt is requested when host interrupt enable bit is set to 1</p>

Bit	Bit Name	Initial Value	Slave	Host	Description
4	SMIE3B	0	R/W	—	<p>Host SMI Interrupt Enable 3B</p> <p>Enables or disables a host SMI interrupt request when OBF3B is set by a TWR15 write.</p> <p>0: Host SMI interrupt request by OBF3B and SMIE3B is disabled</p> <p>[Clearing conditions]</p> <ul style="list-style-type: none"> • Writing 0 to SMIE3B • LPC hardware reset, LPC software reset • Clearing OBF3B to 0 (when IEDIR3 = 0) <p>1: [When IEDIR3 = 0]</p> <p>Host SMI interrupt request by setting OBF3B to 1 is enabled</p> <p>[When IEDIR3 = 1]</p> <p>Host SMI interrupt is requested</p> <p>[Setting condition]</p> <ul style="list-style-type: none"> • Writing 1 after reading SMIE3B = 0
3	SMIE3A	0	R/W	—	<p>Host SMI Interrupt Enable 3A</p> <p>Enables or disables a host SMI interrupt request when OBF3A is set by an ODR3 write.</p> <p>0: Host SMI interrupt request by OBF3A and SMIE3A is disabled</p> <p>[Clearing conditions]</p> <ul style="list-style-type: none"> • Writing 0 to SMIE3A • LPC hardware reset, LPC software reset • Clearing OBF3A to 0 (when IEDIR3 = 0) <p>1: [When IEDIR3 = 0]</p> <p>Host SMI interrupt request by setting OBF3A to 1 is enabled</p> <p>[When IEDIR3 = 1]</p> <p>Host SMI interrupt is requested</p> <p>[Setting condition]</p> <ul style="list-style-type: none"> • Writing 1 after reading SMIE3A = 0

Bit	Bit Name	Initial Value	Slave	Host	Description
2	SMIE2	0	R/W	—	<p>Host SMI Interrupt Enable 2</p> <p>Enables or disables a host SMI interrupt request when OBF2 is set by an ODR2 write.</p> <p>0: Host SMI interrupt request by OBF2 and SMIE2 is disabled</p> <p>[Clearing conditions]</p> <ul style="list-style-type: none"> • Writing 0 to SMIE2 • LPC hardware reset, LPC software reset • Clearing OBF2 to 0 (when IEDIR = 0) <p>1: [When IEDIR = 0]</p> <p>Host SMI interrupt request by setting OBF2 to 1 is enabled</p> <p>[When IEDIR = 1]</p> <p>Host SMI interrupt is requested</p> <p>[Setting condition]</p> <ul style="list-style-type: none"> • Writing 1 after reading SMIE2 = 0
1	IRQ12E1	0	R/W	—	<p>Host IRQ12 Interrupt Enable 1</p> <p>Enables or disables a HIRQ12 interrupt request when OBF1 is set by an ODR1 write.</p> <p>0: HIRQ12 interrupt request by OBF1 and IRQ12E1 is disabled</p> <p>[Clearing conditions]</p> <ul style="list-style-type: none"> • Writing 0 to IRQ12E1 • LPC hardware reset, LPC software reset • Clearing OBF1 to 0 <p>1: HIRQ12 interrupt request by setting OBF1 to 1 is enabled</p> <p>[Setting condition]</p> <ul style="list-style-type: none"> • Writing 1 after reading IRQ12E1 = 0

Bit	Bit Name	Initial Value	R/W		Description
			Slave	Host	
0	IRQ1E1	0	R/W	—	<p>Host IRQ1 Interrupt Enable 1</p> <p>Enables or disables a HIRQ1 interrupt request when OBF1 is set by an ODR1 write.</p> <p>0: HIRQ1 interrupt request by OBF1 and IRQ1E1 is disabled</p> <p>[Clearing conditions]</p> <ul style="list-style-type: none"> • Writing 0 to IRQ1E1 • LPC hardware reset, LPC software reset • Clearing OBF1 to 0 <p>1: HIRQ1 interrupt request by setting OBF1 to 1 is enabled</p> <p>[Setting condition]</p> <ul style="list-style-type: none"> • Writing 1 after reading IRQ1E1 = 0

16.3.11 SERIRQ Control Register 1 (SIRQCR1)

The SIRQCR1 register contains status bits that enable or disable an SERIRQ interrupt request.

The SIRQCR1 register is initialized to H'00 by a reset or in hardware standby mode.

Bit	Bit Name	Initial Value	Slave	Host	Description
7	IRQ11E3	0	R/W	—	<p>Host IRQ11 Interrupt Enable 3</p> <p>Enables or disables a HIRQ11 interrupt request when OBF3A is set by an ODR3 write.</p> <p>0: HIRQ11 interrupt request by OBF3A and IRQ11E3 is disabled</p> <p>[Clearing conditions]</p> <ul style="list-style-type: none"> • Writing 0 to IRQ11E3 • LPC hardware reset, LPC software reset • Clearing OBF3A to 0 (when IEDIR3 = 0) <p>1: [When IEDIR3 = 0]</p> <p>HIRQ11 interrupt request by setting OBF3A to 1 is enabled</p> <p>[When IEDIR3 = 1]</p> <p>HIRQ11 interrupt is requested.</p> <p>[Setting condition]</p> <ul style="list-style-type: none"> • Writing 1 after reading IRQ11E3 = 0
6	IRQ10E3	0	R/W	—	<p>Host IRQ10 Interrupt Enable 3</p> <p>Enables or disables a HIRQ10 interrupt request when OBF3A is set by an ODR3 write.</p> <p>0: HIRQ10 interrupt request by OBF3A and IRQ10E3 is disabled</p> <p>[Clearing conditions]</p> <ul style="list-style-type: none"> • Writing 0 to IRQ10E3 • LPC hardware reset, LPC software reset • Clearing OB3FA to 0 (when IEDIR3 = 0) <p>1: [When IEDIR3 = 0]</p> <p>HIRQ10 interrupt request by setting OBF3A to 1 is enabled</p> <p>[When IEDIR3 = 1]</p> <p>HIRQ10 interrupt is requested.</p> <p>[Setting condition]</p> <ul style="list-style-type: none"> • Writing 1 after reading IRQ10E3 = 0

Bit	Bit Name	Initial Value	Slave	Host	Description
5	IRQ9E3	0	R/W	—	<p>Host IRQ9 Interrupt Enable 3</p> <p>Enables or disables a HIRQ9 interrupt request when OBF3A is set by an ODR3 write.</p> <p>0: HIRQ9 interrupt request by OBF3A and IRQ9E3 is disabled</p> <p>[Clearing conditions]</p> <ul style="list-style-type: none"> • Writing 0 to IRQ9E3 • LPC hardware reset, LPC software reset • Clearing OBF3A to 0 (when IEDIR3 = 0) <p>1: [When IEDIR3 = 0]</p> <p>HIRQ9 interrupt request by setting OBF3A to 1 is enabled</p> <p>[When IEDIR3 = 1]</p> <p>HIRQ9 interrupt is requested.</p> <p>[Setting condition]</p> <ul style="list-style-type: none"> • Writing 1 after reading IRQ9E3 = 0
4	IRQ6E3	0	R/W	—	<p>Host IRQ6 Interrupt Enable 3</p> <p>Enables or disables a HIRQ6 interrupt request when OBF3A is set by an ODR3 write.</p> <p>0: HIRQ6 interrupt request by OBF3A and IRQ6E3 is disabled</p> <p>[Clearing conditions]</p> <ul style="list-style-type: none"> • Writing 0 to IRQ6E3 • LPC hardware reset, LPC software reset • Clearing OBF3A to 0 (when IEDIR3 = 0) <p>1: [When IEDIR3 = 0]</p> <p>HIRQ6 interrupt request by setting OBF3A to 1 is enabled</p> <p>[When IEDIR3 = 1]</p> <p>HIRQ6 interrupt is requested.</p> <p>[Setting condition]</p> <ul style="list-style-type: none"> • Writing 1 after reading IRQ6E3 = 0

Bit	Bit Name	Initial Value	Slave	Host	Description
3	IRQ11E2	0	R/W	—	<p>Host IRQ11 Interrupt Enable 2</p> <p>Enables or disables a HIRQ11 interrupt request when OBF2 is set by an ODR2 write.</p> <p>0: HIRQ11 interrupt request by OBF2 and IRQ11E2 is disabled</p> <p>[Clearing conditions]</p> <ul style="list-style-type: none"> • Writing 0 to IRQ11E2 • LPC hardware reset, LPC software reset • Clearing OBF2 to 0 (when IEDIR = 0) <p>1: [When IEDIR = 0]</p> <p>HIRQ11 interrupt request by setting OBF2 to 1 is enabled</p> <p>[When IEDIR = 1]</p> <p>HIRQ11 interrupt is requested.</p> <p>[Setting condition]</p> <ul style="list-style-type: none"> • Writing 1 after reading IRQ11E2 = 0
2	IRQ10E2	0	R/W	—	<p>Host IRQ10 Interrupt Enable 2</p> <p>Enables or disables a HIRQ10 interrupt request when OBF2 is set by an ODR2 write.</p> <p>0: HIRQ10 interrupt request by OBF2 and IRQ10E2 is disabled</p> <p>[Clearing conditions]</p> <ul style="list-style-type: none"> • Writing 0 to IRQ10E2 • LPC hardware reset, LPC software reset • Clearing OBF2 to 0 (when IEDIR = 0) <p>1: [When IEDIR = 0]</p> <p>HIRQ10 interrupt request by setting OBF2 to 1 is enabled</p> <p>[When IEDIR = 1]</p> <p>HIRQ10 interrupt is requested.</p> <p>[Setting condition]</p> <ul style="list-style-type: none"> • Writing 1 after reading IRQ10E2 = 0

Bit	Bit Name	Initial Value	Slave	Host	Description
1	IRQ9E2	0	R/W	—	<p>Host IRQ9 Interrupt Enable 2</p> <p>Enables or disables a HIRQ9 interrupt request when OBF2 is set by an ODR2 write.</p> <p>0: HIRQ9 interrupt request by OBF2 and IRQ9E2 is disabled</p> <p>[Clearing conditions]</p> <ul style="list-style-type: none"> • Writing 0 to IRQ9E2 • LPC hardware reset, LPC software reset • Clearing OBF2 to 0 (when IEDIR = 0) <p>1: [When IEDIR = 0]</p> <p>HIRQ9 interrupt request by setting OBF2 to 1 is enabled</p> <p>[When IEDIR = 1]</p> <p>HIRQ9 interrupt is requested.</p> <p>[Setting condition]</p> <ul style="list-style-type: none"> • Writing 1 after reading IRQ9E2 = 0
0	IRQ6E2	0	R/W	—	<p>Host IRQ6 Interrupt Enable 2</p> <p>Enables or disables a HIRQ6 interrupt request when OBF2 is set by an ODR2 write.</p> <p>0: HIRQ6 interrupt request by OBF2 and IRQ6E2 is disabled</p> <p>[Clearing conditions]</p> <ul style="list-style-type: none"> • Writing 0 to IRQ6E2 • LPC hardware reset, LPC software reset • Clearing OBF2 to 0 (when IEDIR = 0) <p>1: [When IEDIR = 0]</p> <p>HIRQ6 interrupt request by setting OBF2 to 1 is enabled</p> <p>[When IEDIR = 1]</p> <p>HIRQ6 interrupt is requested.</p> <p>[Setting condition]</p> <ul style="list-style-type: none"> • Writing 1 after reading IRQ6E2 = 0

16.3.12 SERIRQ Control Register 2 (SIRQCR2)

The SIRQCR2 register contains status bits that specify an SERIRQ interrupt source.

The SIRQCR2 register is initialized to H'00 by a reset or in hardware standby mode.

Bit	Bit Name	Initial Value	R/W		Description
			Slave	Host	
7	IEDIR3	0	R/W	—	Interrupt Enable Direct Mode 3 Specifies whether SERIRQ interrupt sources (SMI, HIRQ6, and HIRQ9 to HIRQ11) of LPC channel 3 are generated in relation to OBF or only by the host interrupt enable bit. 0: The host interrupt is requested when both the host interrupt enable bit and corresponding OBF are set to 1 1: The host interrupt is requested when the host interrupt enable bit is set to 1
6 to 0	—	All 0	R/W	—	Reserved The initial value should not be changed.

16.3.13 Host Interface Select Register (HISEL)

HISEL selects the function of bits 7 to 4 in the STR3 register. In addition, this register selects the output of host interrupt request signal of each frame.

Bit	Bit Name	Initial Value	R/W		Description
			Slave	Host	
7	SELSTR3	0	R/W	—	<p>STR3 Register Function Select 3</p> <p>Sets the functions of bits 7 to 4 in STR3 together with the TWRE bit in LADR3L. For details see section 16.3.9, Status Register 1 to 3 (STR1 to STR3).</p> <p>0: Bits 7 to 4 in STR3 is the LPC interface status bits</p> <p>1: [When TWRE = 0] Bits 7 to 4 in STR3 are defined by user.</p> <p>[When TWRE = 1] Bits 7 to 4 in STR3 are the LPC interface status bits.</p>
6	SELIRQ11	All 0	R/W	—	Selects the SERIRQ Output
5	SELIRQ10				<p>These bits select the output status for LPC host interrupt request (HIRQ11, HIRQ10, HIRQ9, HIRQ6, SMI, HIRQ12, and HIRQ1).</p> <p>0: [When host interrupt request has been cleared] The SERIRQ output is high impedance.</p> <p>[When host interrupt request has been set] The SERIRQ output is 0 level.</p> <p>1: [When host interrupt request has been cleared] The SERIRQ output is 0 level.</p> <p>[When host interrupt request has been set] The SERIRQ output is high impedance.</p>
4	SELIRQ9				
3	SELIRQ6				
2	SELSMI				
1	SELIRQ12				
0	SELIRQ1				

16.3.14 SMIC Flag Register (SMICFLG)

SMICFLG is one of the registers used to implement SMIC mode. This register includes bits that indicate whether or not the system is ready to data transfer and those that are used for handshake of the transfer cycles.

Bit	Bit Name	Initial Value	R/W		Description
			Slave	Host	
7	RX_DATA_0 RDY	0	R/W	R	Read Transfer Ready Indicates whether or not the slave is ready for the host read transfer. 0: Slave waits for ready status 1: Slave is ready for the host read transfer
6	TX_DATA_0 RDY	0	R/W	R	Write Transfer Ready Indicates whether or not the slave is ready for the host next write transfer. 0: The slave waits for ready status 1: The slave is ready for the host write transfer.
5	—	0	R/W	R	Reserved The initial value should not be changed.
4	SMI	0	R/W	R	SMI Flag This bit indicates that the SMI is asserted. 0: Indicates waiting for SMI assertion 1: Indicates SMI assertion

R/W

Bit	Bit Name	Initial Value	Slave	Host	Description
3	SEVT_ ATN	0	R/W	R	Event Flag When the slave detects an event for the host, this bit is set. 0: Indicates waiting for event detection 1: Indicates event detection
2	SMS_ ATN	0	R/W	R	SMS Flag When there is a message to be transmitted from the slave to the host, this bit is set. 0: There is not a message 1: There is a message
1	—	0	R/W	R	Reserved The initial value should not be changed.
0	BUSY	0	R/(W)*	W	SMIC Busy This bit indicates that the slave is now transferring data. This bit can be cleared only by the slave and set only by the host. The rising edge of this bit is a source of internal interrupt to the slave. 0: Transfer cycle wait state [Clearing conditions] After the slave reads BUSY = 1, writes 0 to this bit. 1: Transfer cycle in progress [Setting condition] When the host writes 1 to this bit.

Note: Only 0 can be written to clear the flag.

16.3.15 SMIC Control Status Register (SMICCSR)

SMICCSR is one of the registers used to implement SMIC mode. This is an 8-bit readable/writable register that stores a control code issued from the host and a status code that is returned from the slave.

The control code is written to this register accompanied by the transfer between the host and slave. The status code is returned to this register to indicate that the slave has recognized the control code, and a specified transfer cycle has been completed.

16.3.16 SMIC Data Register (SMICDTR)

SMICDTR is one of the registers used to implement SMIC mode. This is an 8-bit register that is accessible (readable/writable) from both the slave processor (this LSI) and host processor. This is used for data transfer between the host and slave.

16.3.17 SMIC Interrupt Register 0 (SMICIR0)

SMICIR0 is one of the registers used to implement SMIC mode. This register includes the bits that indicate the source of interrupt to the slave.

R/W

Bit	Bit Name	Initial Value	Slave	Host	Description
7 to 5	—	All 0	R/W	—	Reserved The initial value should not be changed.
4	HDTWI	0	R/(W)*	—	Transfer Data Transmission End Interrupt This is a status flag that indicates that the host has finished transmitting the transfer data to SMICDTR. When the IBFIE3 bit and HDTWIE bit are set to 1, the IBFI3 interrupt is requested to the slave. 0: Transfer data transmission wait state [Clearing condition] After the slave reads HDTWI = 1, writes 0 to this bit. 1: Transfer data transmission end [Setting condition] The transfer cycle is write transfer and the host writes the transfer data to SMICDTR.
3	HDTRI	0	R/(W)*	—	Transfer Data Receive End Interrupt This is a status flag that indicates that the host has finished receiving the transfer data from SMICDTR. When the IBFIE3 bit and HDTRIE bit are set to 1, the IBFI3 interrupt is requested to the slave. 0: Transfer data receive wait state [Clearing condition] After the slave reads HDTRI = 1, writes 0 to this bit. 1: Transfer data receive end [Setting condition] The transfer cycle is read transfer and the host reads the transfer data from SMICDTR.
2	STARI	0	R/(W)*	—	Status Code Receive End Interrupt This is a status flag that indicates that the host has finished receiving the status code from SMICCSR. When the IBFIE3 bit and STARIE bit are set to 1, the IBFI3 interrupt is requested to the slave. 0: Status code receive wait state [Clearing condition] After the slave reads STARI = 1, writes 0 to this bit. 1: Status code receive end [Setting condition] When the host reads the status code of SMICCSR.

R/W

Bit	Bit Name	Initial Value	Slave	Host	Description
1	CTLWI	0	R/(W)*	—	<p>Control Code Transmission End Interrupt</p> <p>This is a status flag that indicates that the host has finished transmitting the control code to SMICCSR. When the IBFIE3 bit and CTLWIE bit are set to 1, the IBFI3 interrupt is requested to the slave.</p> <p>0: Control code transmission wait state [Clearing condition]</p> <p>After the slave reads CTLWI = 1, writes 0 to this bit.</p> <p>1: Control code transmission end [Setting condition]</p> <p>When the host writes the status code to SMICCSR.</p>
0	BUSYI		R/(W)*	—	<p>Transfer Start Interrupt</p> <p>This is a status flag that indicates that the host starts transferring. When the IBFIE3 bit and BUSYIE bit are set to 1, the IBFI3 interrupt is requested to the slave.</p> <p>0: Transfer start wait state [Clearing condition]</p> <p>After the slave reads BUSYI = 1, writes 0 to this bit.</p> <p>1: Transfer start [Setting condition]</p> <p>When the rising edge of the BUSY bit in SMICFLG is detected.</p>

Note: * Only 0 can be written to clear the flag.

16.3.18 SMIC Interrupt Register 1 (SMICIR1)

SMICIR1 is one of the registers used to implement SMIC mode. This register includes the bits that enables/disables an interrupt to the slave. The IBFI3 interrupt is enabled by setting the IBFIE3 bit in HICR2 to 1.

Bit	Bit Name	Initial Value	R/W		Description
			Slave	Host	
7 to 5	—	All 0	R/W	—	Reserved The initial value should not be changed.
4	HDTWIE	0	R/W	—	Transfer Data Transmission End Interrupt Enable Enables or disables HDTWI interrupt that is IBFI3 interrupt source to the slave. 0: Disables transfer data transmission end interrupt 1: Enables transfer data transmission end interrupt
3	HDTRIE	0	R/W	—	Transfer Data Receive End Interrupt Enable Enables or disables HDTRI interrupt that is IBFI3 interrupt source to the slave. 0: Disables transfer data receive end interrupt 1: Enables transfer data receive end interrupt
2	STARIE	0	R/W	—	Status Code Receive End Interrupt Enable Enables or disables STARI interrupt that is IBFI3 interrupt source to the slave. 0: Disables status code receive end interrupt 1: Enables status code receive end interrupt
1	CTLWIE	0	R/W	—	Control Code Transmission End Interrupt Enable Enables or disables CTLWI interrupt that is IBFI3 interrupt source to the slave. 0: Disables control code transmission end interrupt 1: Enables control code transmission end interrupt
0	BUSYIE	0	R/W	—	Transfer Start Interrupt Enable Enables or disables BUSYI interrupt that is IBFI3 interrupt source to the slave. 0: Disables transfer start interrupt 1: Enables transfer start interrupt

16.3.19 BT Status Register 0 (BTSR0)

BTSR0 is one of the registers used to implement BT mode. This register includes flags that control interrupts to the slave (this LSI).

Bit	Bit Name	Initial Value	R/W		Description
			Slave	Host	
7 to 5	—	All 0	R/W	—	Reserved The initial value should not be changed.
4	FRDI	0	R/(W)*	—	FIFO Read Request Interrupt This status flag indicates that host writes the data to BTDTR buffer with FIFO full state at the host write transfer. When the IBFIE3 bit and FRDIE bit are set to 1, IBFI3 interrupt is requested to the slave. The slave must clear the flag after creating an unused area by reading the data in FIFO. 0: FIFO read is not requested [Clearing condition] After the slave reads FRDI = 1, writes 0 to this bit. 1: FIFO read is requested [Setting condition] After the host processor transfers data, the host writes the data with FIFO Full state.
3	HRDI	0	R/(W)*	—	BT Host Read Interrupt This status flag indicates that the host reads 1 byte from BTDTR buffer. When the IBFIE3 bit and HRDIE bit are set to 1, IBFI3 interrupt is requested to the slave. 0: Host BTDTR read wait state [Clearing condition] After the slave reads HRDI = 1, writes 0 to this bit. 1: The host reads from BTDTR [Setting condition] The host reads one byte from BTDTR.

R/W

Bit	Bit Name	Initial Value	Slave	Host	Description
2	HWRI	0	R/(W)*	—	<p>BT Host Write Interrupt</p> <p>This status flag indicates that the host writes 1byte to BTDTR buffer. When the IBFIE3 bit and HWRIE bit are set to 1, IBFI3 interrupt is requested to the slave.</p> <p>0: Host BTDTR write wait state [Clearing condition]</p> <p>After the slave reads HWRI = 1, writes 0 to this bit.</p> <p>1: The host writes to BTDTR [Setting condition]</p> <p>The host writes one byte to BTDTR.</p>
1	HBTWI	0	R/(W)*	—	<p>BTDTR Host Write Start Interrupt</p> <p>This status flag indicates that the host writes the first byte of valid data to BTDTR buffer. When the IBFIE3 bit and HBTWIE bit are set to 1, IBFI3 interrupt is requested to the slave.</p> <p>0: BTDTR host write start wait state [Clearing condition]</p> <p>After the slave reads HBTWI = 1 and writes 0 to this bit.</p> <p>1: BTDTR host write start [Setting condition]</p> <p>The host starts writing valid data to BTDTR.</p>
0	HBTRI	0	R/(W)*	—	<p>BTDTR Host Read End Interrupt</p> <p>This status flag indicates that the host reads all valid data from BTDTR buffer. When the BFIE3 bit and HBTRIE bit are set to 1, IBFI3 interrupt is requested to the slave.</p> <p>0: BTDTR host read end wait state [Clearing condition]</p> <p>After the slave reads HBTRI = 1 and writes 0 to this bit.</p> <p>1: BTDTR host read end [Setting condition]</p> <p>When the host finished reading the valid data from BTDTR.</p>

Note: * Only 0 can be written to clear the flag.

16.3.20 BT Status Register 1 (BTSR1)

BTSR1 is one of the registers used to implement the BT mode. This register includes a flag that controls an interrupt to the slave (this LSI).

Bit	Bit Name	Initial Value	R/W		Description
			Slave	Host	
7	—	0	R/W	—	Reserved The initial value should not be changed.
6	HRSTI	0	R/(W)*	—	BT Reset Interrupt This status flag indicates that the BMC_HWRST bit in BTIMSR is set to 1 by the host. When the IBFIE3 bit and HRSTIE bit are set to 1, IBFI3 interrupt is requested to the slave. 0: [Clearing condition] When the slave reads HRSTI = 1 and writes 0 to this bit. 1: [Setting condition] When the slave detects the rising edge of BMC_HWRST.
5	IRQCRI	0	R/(W)*	—	B2H_IRQ Clear Interrupt This status flag indicates that the B2H_IRQ bit in BTIMSR is cleared by the host. When the IBFIE3 bit and IRQCRIE bit are set to 1, IBFI3 interrupt is requested to the slave. 0: [Clearing condition] When the slave reads IRQCRI = 1 and writes 0 to this bit. 1: [Setting condition] When the slave detects the falling edge of B2H_IRQ.

Bit	Bit Name	Initial Value	Slave	Host	Description
4	BEVTI	0	R/(W)*	—	<p>BEVT_ATN Clear Interrupt</p> <p>This status flag indicates that the BEVT_ATN bit in BTCR is cleared by the host. When the IBFIE3 bit and BEVTIE bit are set to 1, IBFI3 interrupt is requested to the slave.</p> <p>0: [Clearing condition]</p> <p>When the slave reads BEVTI = 1 and writes 0 to this bit.</p> <p>1: [Setting condition]</p> <p>When the slave detects the falling edge of BEVT_ATN.</p>
3	B2HI	0	R/(W)*	—	<p>Read End Interrupt</p> <p>This status flag indicates that the host has finished reading all data from the BTDTR buffer. When the IBFIE3 bit and B2HIE bit are set to 1, the IBFI3 interrupt is requested to the slave.</p> <p>0: [Clearing condition]</p> <p>When the slave reads B2HI = 1 and writes 0 to this bit.</p> <p>1: [Setting conditions]</p> <p>ATNSW = 0: When the slave detects the falling edge of B2H_ATN.</p> <p>ATNSW = 1: When the slave detects the falling edge of H_BUSY.</p>
2	H2BI	0	R/(W)*	—	<p>Write End Interrupt</p> <p>This status flag indicates that the host has finished writing all data to the BTDTR buffer. When the IBFIE3 bit and H2BIE bit are set to 1, the IBFI3 interrupt is requested to the slave.</p> <p>0: [Clearing condition]</p> <p>After the slave reads H2BI = 1, writes 0 to this bit.</p> <p>1: [Setting condition]</p> <p>When the slave detects the falling edge of H2B_ATN.</p>

Bit	Bit Name	Initial Value	Slave	Host	Description
1	CRRPI	0	R/(W)*	—	<p>Read Pointer Clear Interrupt</p> <p>This status flag indicates that the CLR_RD_PTR bit in BPCR is set to 1 by the host. When the IBFIE3 bit and CRRPIE bit are set to 1, the IBFI3 interrupt is requested to the slave.</p> <p>0: [Clearing condition]</p> <p>After the slave reads CRRPI = 1, writes 0 to this bit.</p> <p>1: [Setting condition]</p> <p>When the slave detects the rising edge of CLR_RD_PTR.</p>
0	CRWPI	0	R/(W)*	—	<p>Write Pointer Clear Interrupt</p> <p>This status flag indicates that the CLR_WR_PTR bit in BPCR is set to 1 by the host. When the IBFIE3 bit and CRWPIE bit are set to 1, the IBFI3 interrupt is requested to the slave.</p> <p>0: [Clearing condition]</p> <p>After the slave reads CRWPI = 1, writes 0 to this bit.</p> <p>1: [Setting condition]</p> <p>When the slave detects the rising edge of CLR_WR_PTR.</p>

Note: * Only 0 can be written to clear the flag.

16.3.21 BT Control Status Register 0 (BTCSR0)

BTCSR0 is one of the registers used to implement the BT mode. The BTCSR0 register contains the bits used to switch FIFOs in BT transfer, and enable or disable the interrupts to the slave (this LSI). The IBFI3 interrupt is enabled by setting the IBFIE3 bit in HICR2 to 1.

Bit	Bit Name	Initial Value	R/W		Description
			Slave	Host	
7	—	0	R/W	—	Reserved The initial value should not be changed.
6	FSEL1	0	R/W	—	These bits select either FIFO during BT transfer FSEL1 FSEL0 0 * :FIFO disabled 1 * :FIFO enabled The FIFO size: 64 bytes (for host write transfer), additional 64 bytes (for host read transfer).
5	FSEL0	0	R/W	—	
4	FRDIE	0	R/W	—	
3	HRDIE	0	R/W	—	BT Host Read Interrupt Enable Enables or disables the HRDI interrupt which is an IBFI3 interrupt source to the slave. When using FIFO, the HRDIE bit must not be set to 1. 0: BT host read interrupt is disabled. 1: BT host read interrupt is enabled.
2	HWRIE	0	R/W	—	BT Host Write Interrupt Enable Enables or disables the HWRI interrupt which is an IBFI3 interrupt source to the slave. When using FIFO, the HWRIE bit must not be set to 1. 0: BT host write interrupt is disabled. 1: BT host write interrupt is enabled.

Bit	Bit Name	Initial Value	R/W		Description
			Slave	Host	
1	HBTWIE	0	R/W	—	BTDTR Host Write Start Interrupt Enable Enables or disables the HBTWI interrupt which is an IBFI3 interrupt source to the slave. 0: BTDTR host write start interrupt is disabled. 1: BTDTR host write start interrupt is enabled.
0	HBTRIE	0	R/W	—	BTDTR Host Read End Interrupt Enable Enables or disables the HBTRI interrupt which is an IBFI3 interrupt source to the slave. 0: BTDTR host read end interrupt is disabled. 1: BTDTR host read end interrupt is enabled.

Note: * Don't care.

16.3.22 BT Control Status Register 1 (BTCSR1)

BTCSR1 is one of the registers used to implement the BT mode. The BTCSR1 register contains the bits used to enable or disable interrupts to the slave (this LSI). The IBFI3 interrupt is enabled by setting the IBFIE3 bit in HICR2 to 1.

Bit	Bit Name	Initial Value	R/W		Description
			Slave	Host	
7	RSTRENBL	0	R/W	—	Slave Reset Read Enable The host reads 0 from the BMC_HWRST bit in BTIMSR. When this bit is set to 1, the host can read 1 from the BMC_HWRST bit. 0: Host always reads 0 from BMC_HWRST 1: Host can reads 0 from BMC_HWRST
6	HRSTIE	0	R/W	—	BT Reset Interrupt Enable Enables or disables the HRSTI interrupt which is an IBFI3 interrupt source to the slave. 0: BT reset interrupt is disabled. 1: BT reset interrupt is enabled.
5	IRQCRIE	0	R/W	—	B2H_IRQ Clear Interrupt Enable Enables or disables the IRQCRI interrupt which is an IBFI3 interrupt source to the slave. 0: B2H_IRQ clear interrupt is disabled. 1: B2H_IRQ clear interrupt is enabled.

Bit	Bit Name	Initial Value	R/W		Description
			Slave	Host	
4	BEVTIE	0	R/W	—	<p>BEVT_ATN Clear Interrupt Enable</p> <p>Enables or disables the BEVTI interrupt which is an IBFI3 interrupt source to the slave.</p> <p>0: BEVT_ATN clear interrupt is disabled.</p> <p>1: BEVT_ATN clear interrupt is enabled.</p>
3	B2HIE	0	R/W	—	<p>Read End Interrupt Enable</p> <p>Enables or disables the B2HI interrupt which is an IBFI3 interrupt source to the slave.</p> <p>0: Read end interrupt is disabled.</p> <p>1: Read end interrupt is enabled.</p>
2	H2BIE	0	R/W	—	<p>Write End Interrupt Enable</p> <p>Enables or disables the H2BI interrupt which is an IBFI3 interrupt source to the slave.</p> <p>0: Write end interrupt is disabled.</p> <p>1: Write end interrupt is enabled.</p>
1	CRRPIE	0	R/W	—	<p>Read Pointer Clear Interrupt Enable</p> <p>Enables or disables the CRRPI interrupt which is an IBFI3 interrupt source to the slave.</p> <p>0: Read pointer clear interrupt is disabled.</p> <p>1: Read pointer clear interrupt is enabled.</p>
0	CRWPIE	0	R/W	—	<p>Write Pointer Clear Interrupt Enable</p> <p>Enables or disables the CRWPI interrupt which is an IBFI3 interrupt source to the slave.</p> <p>0: Write pointer clear interrupt is disabled.</p> <p>1: Write pointer clear interrupt is enabled.</p>

16.3.23 BT Control Register (BTCR)

BTCR is one of the registers used to implement BT mode. The BTCR register contains bits used in transfer cycle handshaking, and those indicating the completion of data transfer to the buffer.

Bit	Bit Name	Initial Value	R/W		Description
			Slave	Host	
7	B_BUSY	1	R/W	R	<p>BT Write Transfer Busy Flag</p> <p>Read-only bit from the host. Indicates that the BTDTR buffer is being used for BT write transfer (write transfer is in progress.)</p> <p>0: Indicates waiting for BT write transfer</p> <p>1: Indicates that the BTDTR buffer is being used</p>
6	H_BUSY	0	R	(W)* ³	<p>BT Read Transfer Busy Flag</p> <p>This is a set/clear bit from the host. Indicates that the BTDTR buffer is being used for BT read transfer (read transfer is in progress.)</p> <p>0: Indicates waiting for BT read transfer</p> <p>[Clearing condition]</p> <p>When the host writes a 1 while H_BUSY is set to 1.</p> <p>1: Indicates that the BTDTR buffer is being used</p> <p>[Setting condition]</p> <p>When the host writes a 1 while H_BUSY is set to 0.</p>
5	OEM0	0	R/W	R/(W)* ⁴	<p>User defined bit</p> <p>This bit is defined by the user, and validated only when set to 1 by a 0 written from the host.</p> <p>0: [Clearing condition]</p> <p>When the slave writes a 0 after a 1 has been read from OEM0.</p> <p>1: [Setting condition]</p> <p>When the slave writes a 1, after a 0 has been read from OEM0, or when the host writes a 0.</p>

Bit	Bit Name	Initial Value	Slave	Host	Description
4	BEVT_ATN	0	R/(W)* ¹	R/(W)* ⁵	<p>Event Interrupt</p> <p>Sets when the slave detects an event to the host. Setting the B2H_IRQ_EN bit in the BTIMSR register enables the BEVT_ATN bit to be used as an interrupt source to the host.</p> <p>0: No event interrupt request is available [Clearing condition]</p> <p>When the host writes a 1 to the bit.</p> <p>1: An event interrupt request is available [Setting condition]</p> <p>When the slave writes a 1 after a 0 has been read from BEVT_ATN.</p>
3	B2H_ATN	0	R/(W)* ¹	R/(W)* ⁵	<p>Slave Buffer Write End Indication Flag</p> <p>This status flag indicates that the slave has finished writing all data to the BTDTR buffer. Setting the B2H_IRQ_EN bit in the BTIMSR register enables the B2H_ATN bit to be used as an interrupt source to the host.</p> <p>0: Host has completed reading the BTDTR buffer [Clearing condition]</p> <p>When the host writes a 1</p> <p>1: Slave has completed writing to the BTDTR buffer [Setting condition]</p> <p>When the slave writes a 1 after a 0 has been read from B2N_ATN.</p>
2	H2B_ATN	0	R/(W)* ²	R/(W)* ¹	<p>Host Buffer Write End Indication Flag</p> <p>This status flag indicates that the host has finished writing all data to the BTDTR buffer.</p> <p>0: Slave has completed reading the BTDTR buffer [Clearing condition]</p> <p>When the slave writes a 0 after a 1 has been read from H2B_ATN.</p> <p>1: Host has completed writing to the BTDTR buffer [Setting condition]</p> <p>When the host writes a 1</p>

R/W

Bit	Bit Name	Initial Value	Slave	Host	Description
1	CLR_RD_PTR	0	R/(W)* ²	(W)* ¹	<p>Read Pointer Clear</p> <p>This bit is used by the host to clear the read pointer during read transfer. A host read operation always yields 0 on readout.</p> <p>0: Read pointer clear wait [Clearing condition]</p> <p>When the slave writes a 0 after a 1 has been read from CLR_RD_PTR.</p> <p>1: Read pointer clear [Setting condition]</p> <p>When the host writes a 1.</p>
0	CLR_WR_PTR	0	R/(W)* ²	(W)* ¹	<p>Write Pointer Clear</p> <p>This bit is used by the host to clear the write pointer during write transfer. A host read operation always yields 0 on readout.</p> <p>0: Write pointer clear wait [Clearing condition]</p> <p>When the slave writes a 0 after a 1 has been read from CLR_WR_PTR.</p> <p>1: Write pointer clear [Setting condition]</p> <p>When the host writes a 1.</p>

- Notes:
1. Only 1 can be written to set this flag.
 2. Only 0 can be written to clear this flag.
 3. Only 1 can be written to toggle this flag.
 4. Only 0 can be written to set this flag.
 5. Only 1 can be written to clear this flag.

16.3.24 BT Data Buffer (BTDTR)

BTDTR is used to implement the BT mode. BTDTR consists of two FIFOs: the host write transfer FIFO and the host read transfer FIFO. Their capacities are 64 bytes each. When using BTDTR, enable FIFO by means of the bits FSEL0 and FSEL1.

Bit	Bit Name	Initial Value	R/W		Description
			Slave	Host	
7 to 0	bit7 to bit0	Undefined	R/W	R/W	The data written by the host is stored in FIFO (64 bytes) for host write transfer and read out by the slave in order of host writing. The data written by the slave is stored in FIFO (64 bytes) for host read transfer and read out by the host in order of slave writing.

16.3.25 BT Interrupt Mask Register (BTIMSR)

BTIMSR is one of the registers used to implement BT mode.

The BTIMSR register contains the bits used to control the interrupts to the host.

Bit	Bit Name	Initial Value	R/W		Description
			Slave	Host	
7	BMC_ HWRST	0	R/(W)* ²	R/(W)* ¹	<p>Slave Reset</p> <p>Performs a reset from the host to the slave. The host can only write a 1. Writing a 0 to this bit is invalid. The host will always return a 0 on read out. Setting the RSTRENBL bit enables a 1 to be read from the host.</p> <p>0: The reset is cancelled [Clearing condition]</p> <p>When the slave writes a 0, after a 1 has been read from BMC_HWRST.</p> <p>1: The reset is in progress. [Setting condition]</p> <p>When the host writes a 1.</p>
6	—	0	R/W	R/W	Reserved
5	—	0	R/W	R/W	Reserved
4	OEM3	0	R/W	R/(W)* ⁴	User defined bit
3	OEM2	0	R/W	R/(W)* ⁴	<p>These bits are defined by the user and are valid only when set to 1 by a 0 written from the host.</p> <p>0: [Clearing condition] When the slave writes a 0, after a 1 has been read from OEM.</p> <p>1: [Setting condition] When the slave writes a 1, after a 0 has been read from OEM, or when the host writes a 0.</p>
2	OEM1	0	R/W	R/(W)* ⁴	

R/W

Bit	Bit Name	Initial Value	Slave	Host	Description
1	B2H_IRQ	0	R/(W)* ¹	R/(W)* ³	<p>BMC to HOST interrupt</p> <p>Informs the host that an interrupt has been requested when the BEVT_ATN or B2H_ATN bit has been set. The SERIRQ is not issued. To generate the SERIRQ, it should be issued by the program.</p> <p>0: B2H_IRQ interrupt is not requested [Clearing condition]</p> <p>When the host writes a 1.</p> <p>1: B2H_IRQ interrupt is requested [Setting condition]</p> <p>When the slave writes a 1, after a 0 has been read from B2H_IRQ</p>
0	B2H_IRQ_EN	0	R	R/W	<p>BMC to HOST interrupt enable</p> <p>Enables or disables the B2H_IRQ interrupt which is an the interrupt source from the slave to the host.</p> <p>0: B2H_IRQ interrupt is disabled [Clearing condition]</p> <p>When a 0 is written by the host.</p> <p>1: B2H_IRQ interrupt is enabled [Setting condition]</p> <p>When a 1 is written by the host.</p>

- Notes:
1. Only 1 can be written to set this flag.
 2. Only 0 can be written to clear this flag.
 3. Only 1 can be written to clear this flag.
 4. Only 0 can be written to set this flag.

16.3.26 BT FIFO Valid Size Register 0 (BTFVSR0)

BTFVSR0 is one of the registers used to implement BT mode. BTFVSR0 indicates a valid data size in the FIFO for host write transfer.

Bit	Bit Name	Initial Value	R/W		Description
			Slave	Host	
7 to 0	N7 to N0	All 0	R	—	These bits indicate the number of valid bytes in the FIFO (the number of bytes which the slave can read) for host write transfer. When data is written from the host, the value in BTFVSR0 is incremented by the number of bytes that have been written to. Further, when data is read from the slave, the value is decremented by only the number of bytes that have been read.

16.3.27 BT FIFO Valid Size Register 1 (BTFVSR1)

BTFVSR1 is one of the registers used to implement BT mode. BTFVSR1 indicates a valid data size in the FIFO for host read transfer.

Bit	Bit Name	Initial Value	R/W		Description
			Slave	Host	
7 to 0	N7 to N0	All 0	R	—	These bits indicate the number of valid bytes in the FIFO (the number of bytes which the host can read) for host read transfer. When data is written from the slave, the value in BTFVSR1 is incremented by the number of bytes that have been written to. Further, when data is read from the host, the value is decremented by only the number of bytes that have been read.

16.4 Operation

16.4.1 LPC Interface Activation

The LPC interface is activated by setting at least one of bits LPC3E to LPC1E (bits 7 to 5) in HICR0 to 1. When the LPC interface is activated, the related I/O ports (PE7 to PE0, PD5, and PD4) function as dedicated LPC interface input/output pins. In addition, setting the FGA20E, PMEE, LSMIE, and LSCIE bits to 1 adds the related I/O ports (ports PD3 to PD0) to the LPC interface's input/output pins.

Use the following procedure to activate the LPC interface after a reset release.

1. Read the signal line status and confirm that the LPC module can be connected. Also check that the LPC module is initialized internally.
2. Set the I/O addresses of the channels to be used (LADR1 to LADR3) and whether or not the bidirectional registers, KCS interface, SMIC interface, and BT interface are to be used.
3. Set the enable bit (LPC3E to LPC1E) for the channel to be used.
4. Set the enable bits (FGA20E, PMEE, LSMIE, and LSCIE) for the additional functions to be used.
5. Set the selection bits for other functions (SDWNE, IEDIR).
6. As a precaution, clear the interrupt flags (LRST, SDWN, ABRT, and OBF). Read IDR or TWR15 to clear IBF.
7. Set interrupt enable bits (IBFIE3 to IBFIE1, ERRIE) as necessary.

16.4.2 LPC I/O Cycles

There are ten kinds of LPC transfer cycle: memory read, memory write, I/O read, I/O write, DMA read, DMA write, bus mastership memory read, bus mastership memory write, bus mastership I/O read, and bus mastership I/O write. Of these, the chip's LPC supports only I/O read and I/O write cycles.

An LPC transfer cycle is started when the $\overline{\text{LFRAME}}$ signal goes low in the bus idle state. If the $\overline{\text{LFRAME}}$ signal goes low when the bus is not idle, this means that a forced termination (abort) of the LPC transfer cycle has been requested.

In an I/O read cycle or I/O write cycle, transfer is carried out using LAD3 to LAD0 in the following order, in synchronization with LCLK. The host can be made to wait by sending back a value other than B'0000 in the slave's synchronization return cycle. However, the LPC in this LSI always returns a value of B'0000 if the BT interface is not used.

If the received address matches the host address in an LPC register, the LPC interface enters the busy state; it returns to the idle state by output of a state #12 turnaround. Register (IDR, etc.) and flag (IBF, etc.) changes are made at this timing, so in the event of a transfer cycle forced termination (abort) before state #12, registers and flags are not changed.

Table 16.5 I/O Read and Write Cycles

State Count	I/O Read Cycle			I/O Write Cycle		
	Contents	Drive Source	Value (3 to 0)	Contents	Drive Source	Value (3 to 0)
1	Start	Host	B'0000	Start	Host	B'0000
2	Cycle type/direction	Host	B'0000	Cycle type/direction	Host	B'0010
3	Address 1	Host	Bits 15 to 12	Address 1	Host	Bits 15 to 12
4	Address 2	Host	Bits 11 to 8	Address 2	Host	Bits 11 to 8
5	Address 3	Host	Bits 7 to 4	Address 3	Host	Bits 7 to 4
6	Address 4	Host	Bits 3 to 0	Address 4	Host	Bits 3 to 0
7	Turnaround (recovery)	Host	B'1111	Data 1	Host	Bits 3 to 0
8	Turnaround	None	B'ZZZZ	Data 2	Host	Bits 7 to 4
9	Synchronization	Slave	B'0000	Turnaround (recovery)	Host	B'1111
10	Data 1	Slave	Bits 3 to 0	Turnaround	None	B'ZZZZ
11	Data 2	Slave	Bits 7 to 4	Synchronization	Slave	B'0000
12	Turnaround (recovery)	Slave	B'1111	Turnaround (recovery)	Slave	B'1111
13	Turnaround	None	B'ZZZZ	Turnaround	None	B'ZZZZ

The timing of the $\overline{\text{LFRAME}}$, LCLK, and LAD signals is shown in figures 16.2 and 16.3.

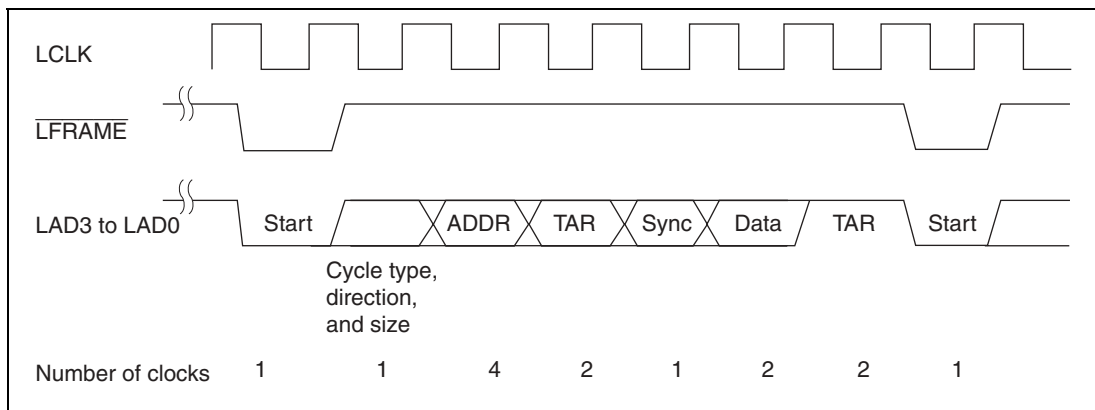

Figure 16.2 Typical $\overline{\text{LFRAME}}$ Timing

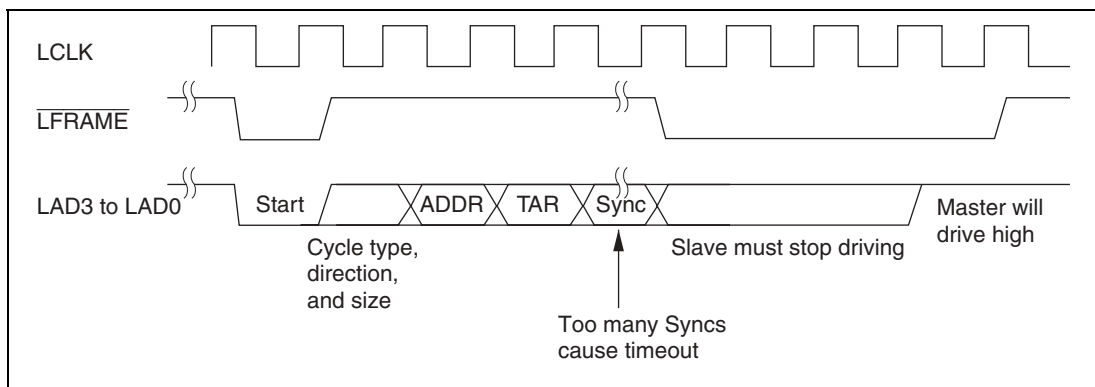

Figure 16.3 Abort Mechanism

16.4.3 SMIC Mode Transfer Flow

Figure 16.4 shows the write transfer flow and figure 16.5 shows the read transfer flow in SMIC mode.

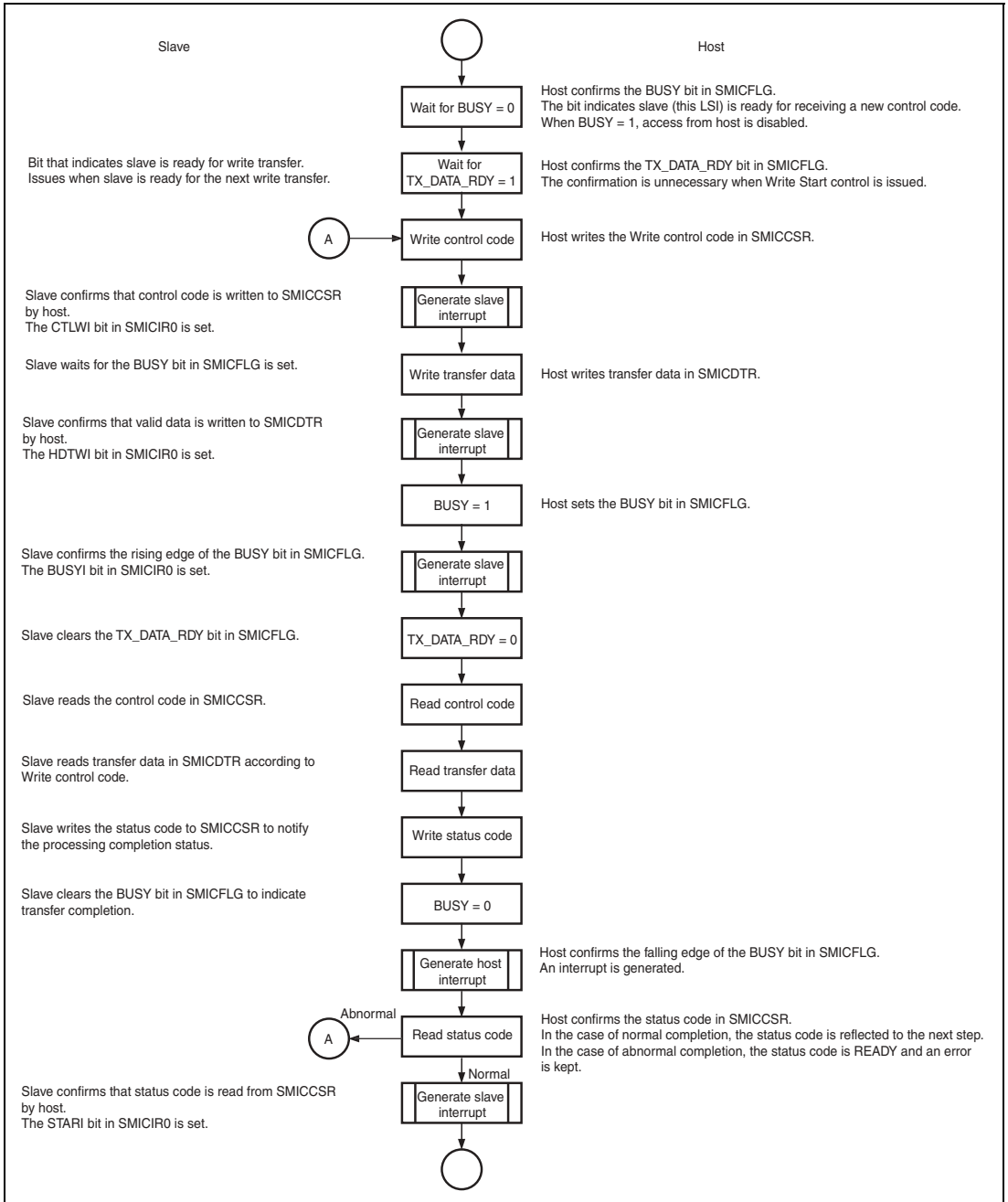

Figure 16.4 SMIC Write Transfer Flow

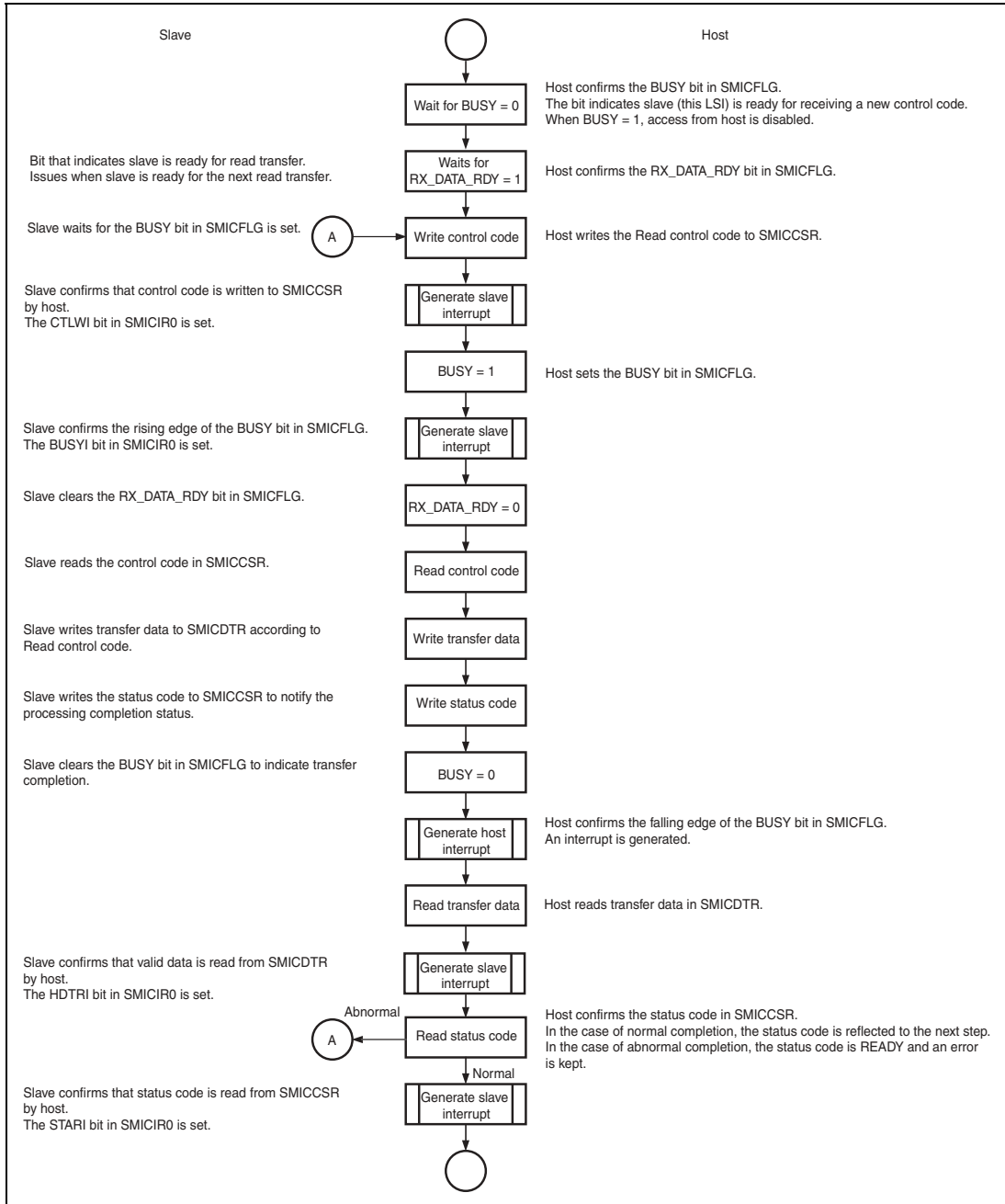

Figure 16.5 SMIC Read Transfer Flow

16.4.4 BT Mode Transfer Flow

Figure 16.6 shows the write transfer flow and figure 16.7 shows the read transfer flow in BT mode.

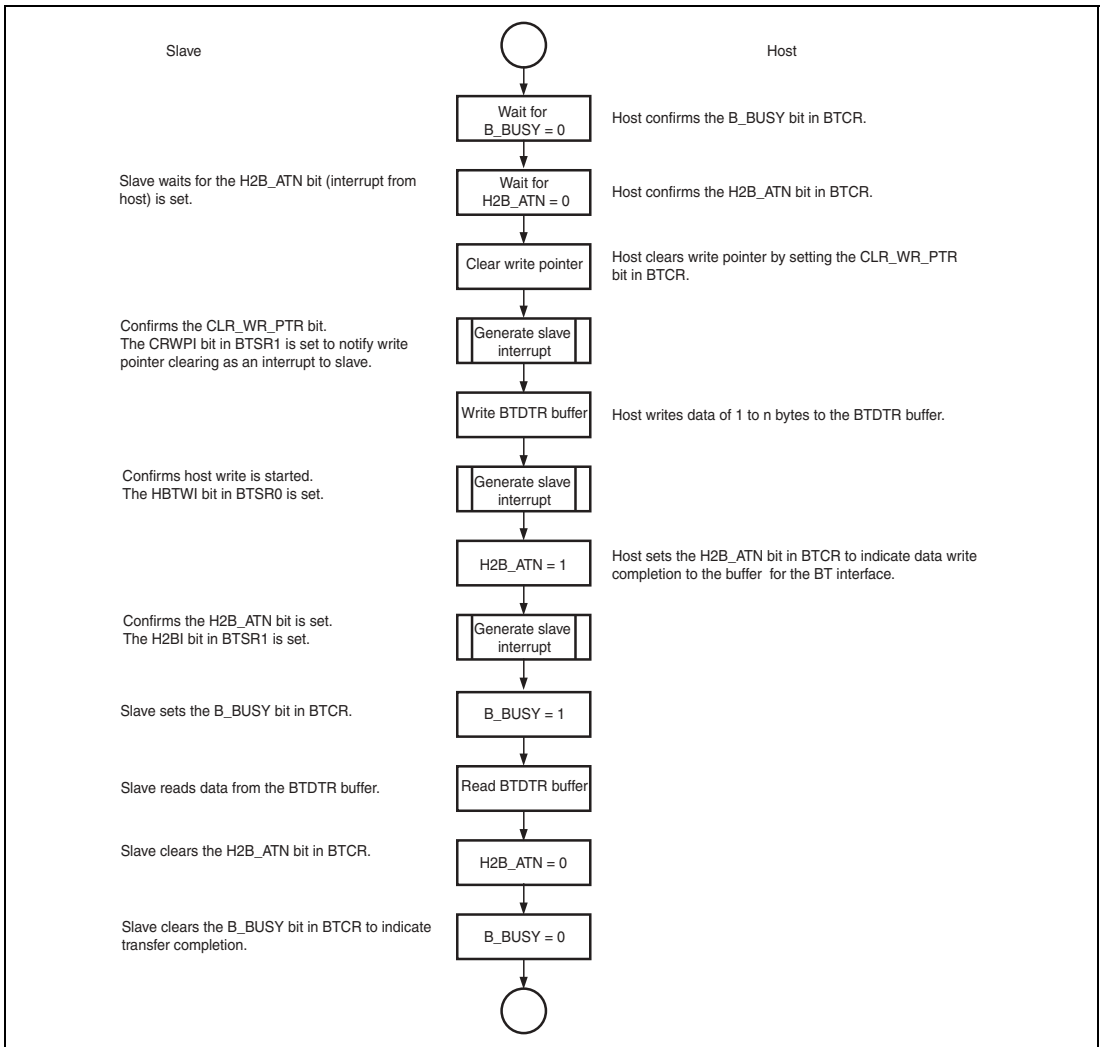

Figure 16.6 BT Write Transfer Flow

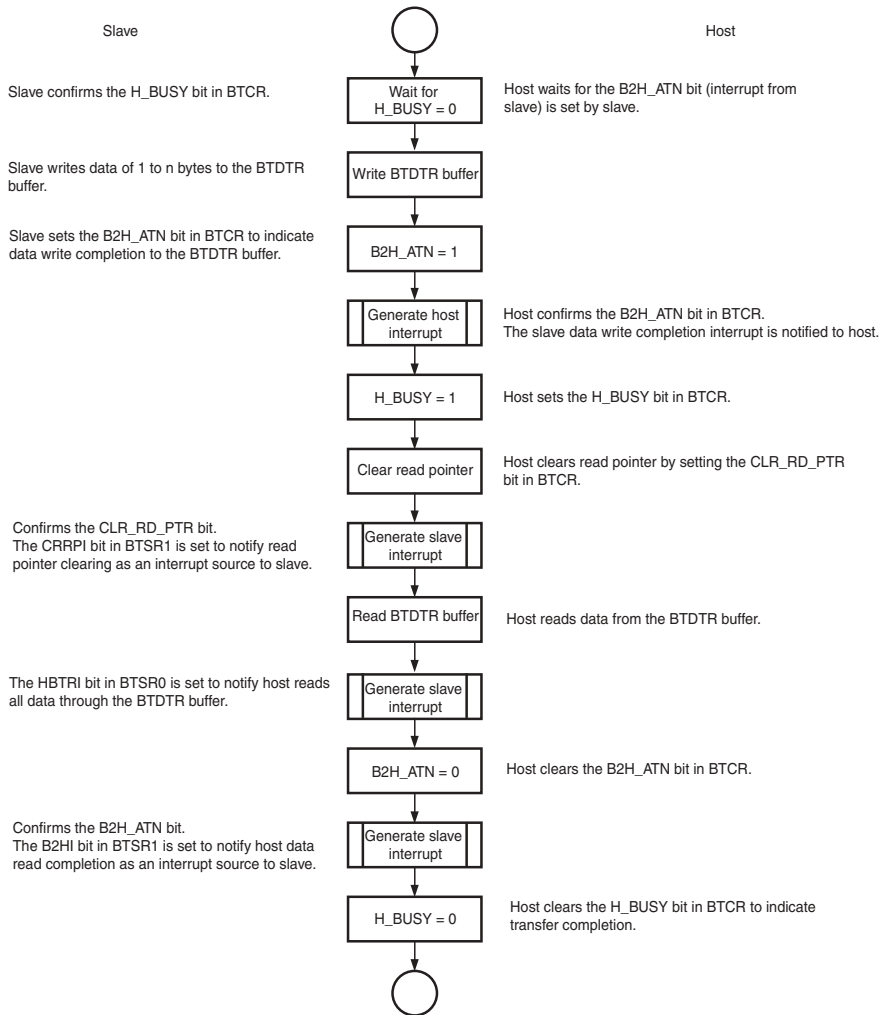

Figure 16.7 BT Read Transfer Flow

16.4.5 A20 Gate

The A20 gate signal can mask address A20 to emulate an addressing mode used by personal computers with an 8086-family CPU*. A regular-speed A20 gate signal can be output under firmware control. The fast A20 gate function that is speeded up by the hardware is enabled by setting the FGA20E bit to 1 in HICR0.

Note: * An Intel microcomputer

Regular A20 Gate Operation: Output of the A20 gate signal can be controlled by an H'D1 command followed by data. When the slave processor (this LSI) receives data, it normally uses an interrupt routine activated by the IBF11 interrupt to read IDR1. If the data follows an H'D1 command, firmware copies bit 1 of the data and outputs it at the gate A20 pin.

Fast A20 Gate Operation: The internal state of GA20 output is initialized to 1 when FGA20E = 0. When the FGA20E bit is set to 1, PD3/GA20 is used for output of a fast A20 gate signal. The state of the PD3/GA20 pin can be monitored by reading the GA20 bit in HICR2.

The initial output from this pin will be a logic 1, which is the initial value. Afterward, the host processor can manipulate the output from this pin by sending commands and data. This function is only available via the IDR1 register. The LPC interface decodes commands input from the host. When an H'D1 host command is detected, bit 1 of the data following the host command is output from the GA20 output pin. This operation does not depend on firmware or interrupts, and is faster than the regular processing using interrupts. Table 16.6 shows the conditions that set and clear GA20 (PD3). Figure 16.8 shows the GA20 output in flowchart form. Table 16.7 indicates the GA20 output signal values.

Table 16.6 GA20 (PD3) Set/Clear Conditions

Pin Name	Setting Condition	Clearing Condition
GA20 (PD3)	When bit 1 of the data that follows an H'D1 host command is 1	When bit 1 of the data follows an H'D1 host command is 0

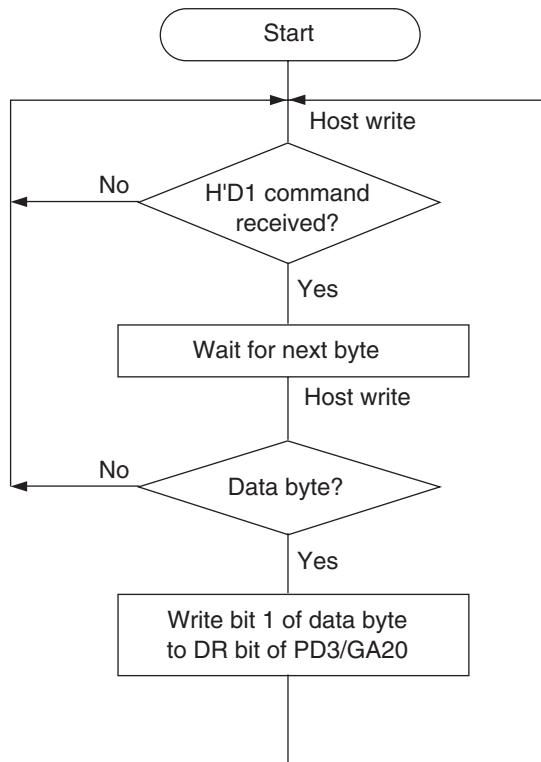

Figure 16.8 GA20 Output

Table 16.7 Fast A20 Gate Output Signals

C/\bar{D}1	Data/Command	Internal CPU Interrupt Flag (IBF)	GA20 (PD3)	Remarks
1	H'D1 command	0	Q	Turn-on sequence
0	1 data* ¹	0	1	
1	H'FF command	0	Q (1)	
1	H'D1 command	0	Q	Turn-off sequence
0	0 data* ²	0	0	
1	H'FF command	0	Q (0)	
1	H'D1 command	0	Q	Turn-on sequence
0	1 data* ¹	0	1	(abbreviated form)
1/0	Command other than H'FF and H'D1	1	Q (1)	
1	H'D1 command	0	Q	Turn-off sequence
0	0 data* ²	0	0	(abbreviated form)
1/0	Command other than H'FF and H'D1	1	Q (0)	
1	H'D1 command	0	Q	Cancelled sequence
1	Command other than H'D1	1	Q	
1	H'D1 command	0	Q	Retriggered sequence
1	H'D1 command	0	Q	Consecutively executed
0	Any data	0	1/0	sequences
1	H'D1 command	0	Q (1/0)	

Notes: 1. Arbitrary data with bit 1 set to 1.
 2. Arbitrary data with bit 1 cleared to 0.

16.4.6 LPC Interface Shutdown Function (LPCPD)

The LPC interface can be placed in the shutdown state according to the state of the $\overline{\text{LPCPD}}$ pin. There are two kinds of LPC interface shutdown state: LPC hardware shutdown and LPC software shutdown. The LPC hardware shutdown state is controlled by the $\overline{\text{LPCPD}}$ pin, while the LPC software shutdown state is controlled by the SDWNB bit. In both states, a part of the LPC interface enters the reset state by itself, and is no longer affected by external signals other than the $\overline{\text{LRESET}}$ and $\overline{\text{LPCPD}}$ signals.

Placing the slave processor in sleep mode or software standby mode is effective in reducing current dissipation in the shutdown state. If software standby mode is set, some means must be provided for exiting software standby mode before clearing the shutdown state with the $\overline{\text{LPCPD}}$ signal.

If the SDWNE bit has been set to 1 beforehand, the LPC hardware shutdown state is entered at the same time as the $\overline{\text{LPCPD}}$ signal falls, and prior preparation is not possible. If the LPC software shutdown state is set by means of the SDWNB bit, on the other hand, the LPC software shutdown state cannot be cleared at the same time as the rise of the $\overline{\text{LPCPD}}$ signal. Taking these points into consideration, the following operating procedure uses a combination of LPC software shutdown and LPC hardware shutdown.

1. Clear the SDWNE bit to 0.
2. Set the ERRIE bit to 1 and wait for an interrupt by the SDWN flag.
3. When an ERRI interrupt is generated by the SDWN flag, check the LPC interface internal status flags and perform any necessary processing.
4. Set the SDWNB bit to 1 to set LPC software shutdown mode.
5. Set the SDWNE bit to 1 and make a transition to LPC hardware shutdown mode. The SDWNB bit is cleared automatically.
6. Check the state of the $\overline{\text{LPCPD}}$ signal to make sure that the $\overline{\text{LPCPD}}$ signal has not risen during steps 3 to 5. If the signal has risen, clear the SDWNE bit to 0 to return to the state in step 1.
7. Place the slave processor in sleep mode or software standby mode as necessary.
8. If software standby mode has been set, exit software standby mode by some means independent of the LPC.
9. When a rising edge is detected in the $\overline{\text{LPCPD}}$ signal, the SDWNE bit is automatically cleared to 0. If the slave processor has been placed in sleep mode, the mode is exited by means of $\overline{\text{LRESET}}$ signal input, on completion of the LPC transfer cycle, or by some other means.

Table 16.8 shows the scope of LPC interface pin shutdown.

Table 16.8 Scope of LPC Interface Pin Shutdown

Abbreviation	Port	Scope of Shutdown	I/O	Notes
LAD3 to LAD0	PE3 to PE0	O	I/O	Hi-Z
$\overline{\text{LFRAME}}$	PE4	O	Input	Hi-Z
$\overline{\text{LRESET}}$	PE5	X	Input	LPC hardware reset function is active
LCLK	PE6	O	Input	Hi-Z
SERIRQ	PE7	O	I/O	Hi-Z
LSCI	PD0	Δ	I/O	Hi-Z, only when LSCIE = 1
$\overline{\text{LSMI}}$	PD1	Δ	I/O	Hi-Z, only when LSMIE = 1
$\overline{\text{PME}}$	PD2	Δ	I/O	Hi-Z, only when PMEE = 1
GA20	PD3	Δ	I/O	Hi-Z, only when FGA20E = 1
$\overline{\text{CLKRUN}}$	PD4	O	I/O	Hi-Z
$\overline{\text{LPCPD}}$	PD5	X	Input	Needed to clear shutdown state

Notes: O: Pins shut down by the shutdown function

Δ : Pins shut down only when the LPC function is selected by register setting

X: Pins not shut down

In the LPC shutdown state, the LPC's internal state and some register bits are initialized. The order of priority of LPC shutdown and reset states is as follows.

1. System reset (reset by $\overline{\text{STBY}}$ or $\overline{\text{RES}}$ pin input, or WDT0 overflow)
 - All register bits, including bits LPC3E to LPC1E, are initialized.
2. LPC hardware reset (reset by $\overline{\text{LRESET}}$ pin input)
 - LRSTB, SDWNE, and SDWNB bits are cleared to 0.
3. LPC software reset (reset by LRSTB)
 - SDWNE and SDWNB bits are cleared to 0.
4. LPC hardware shutdown
 - SDWNB bit is cleared to 0.
5. LPC software shutdown

The scope of the initialization in each mode is shown in table 16.9.

Table 16.9 Scope of Initialization in Each LPC Interface Mode

Items Initialized	System Reset	LPC Reset	LPC Shutdown
LPC transfer cycle sequencer (internal state), LPCBSY and ABRT flags	Initialized	Initialized	Initialized
SERIRQ transfer cycle sequencer (internal state), CLKREQ and IRQBSY flags	Initialized	Initialized	Initialized
LPC interface flags (IBF1, IBF2, IBF3A, IBF3B, MWMF, C/ \bar{D} 1, C/ \bar{D} 2, C/ \bar{D} 3, OBF1, OBF2, OBF3A, OBF3B, SWMF, DBU, SMICFLG, SMICIR0, BTSR0, BTSR1, BTCR, BTIMSR, BTFVSR0, BTFVSR1), GA20 (internal state)	Initialized	Initialized	Retained
Host interrupt enable bits (IRQ1E1, IRQ12E1, SMIE2, IRQ6E2, IRQ9E2 to IRQ11E2, SMIE3B, SMIE3A, IRQ6E3, IRQ9E3 to IRQ11E3, SELREQ, IEDIR, IEDIR3, SMICIR1), Q/ \bar{C} flag	Initialized	Initialized	Retained
LRST flag	Initialized (0)	Can be set/cleared	Can be set/cleared
SDWN flag	Initialized (0)	Initialized (0)	Can be set/cleared
LRSTB bit	Initialized (0)	HR: 0 SR: 1	0 (can be set)
SDWNB bit	Initialized (0)	Initialized (0)	HS: 0 SS: 1
SDWNE bit	Initialized (0)	Initialized (0)	HS: 1 SS: 0 or 1
LPC interface operation control bits (LPC3E to LPC1E, FGA20E, LADR12, LADR3, IBFIE1 to IBFIE3, PMEE, PMEB, LSMIE, LSMIB, LSCIE, LSCIB, TWRE, SELSTR3, SELIRQ1, SELSMI, SELIRQ6, SELIRQ9, SELIRQ10, SELIRQ11, SELIRQ12, HICR4, HISEL, BTCSR0, BTCSR1)	Initialized	Retained	Retained
$\overline{\text{LRESET}}$ signal	Input (port function)	Input	Input
$\overline{\text{LPCPD}}$ signal		Input	Input
LAD3 to LAD0, $\overline{\text{LFRAME}}$, LCLK, SERIRQ, CLKRUN signals		Input	Hi-Z
$\overline{\text{PME}}$, $\overline{\text{LSMI}}$, LSCI, GA20 signals (when function is selected)		Output	Hi-Z
$\overline{\text{PME}}$, $\overline{\text{LSMI}}$, LSCI, GA20 signals (when function is not selected)		Port function	Port function

Notes: System reset: Reset by STBY input, RES input, or WDT overflow

LPC reset: Reset by LPC hardware reset (HR) or LPC software reset (SR)

LPC shutdown: Reset by LPC hardware shutdown (HS) or LPC software shutdown (SS)

Figure 16.9 shows the timing of the $\overline{\text{LPCPD}}$ and $\overline{\text{LRESET}}$ signals.

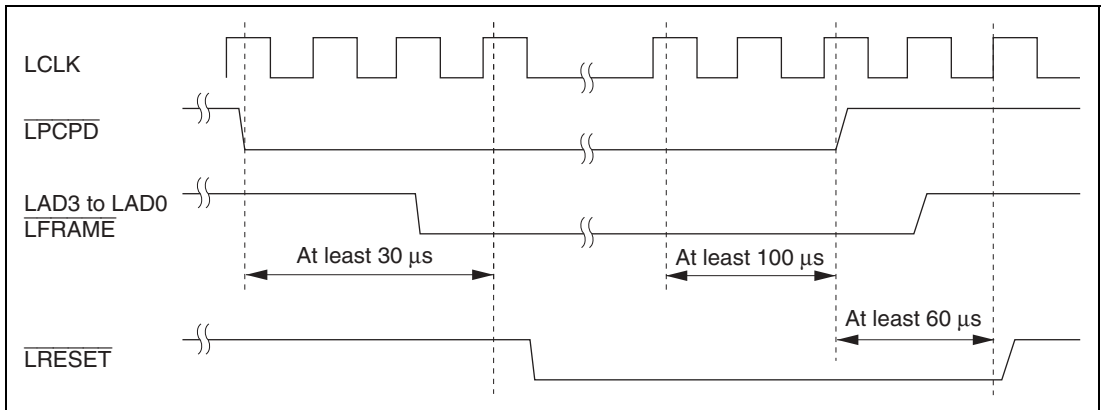

Figure 16.9 Power-Down State Termination Timing

16.4.7 LPC Interface Serialized Interrupt Operation (SERIRQ)

A host interrupt request can be issued from the LPC interface by means of the SERIRQ pin. In a host interrupt request via the SERIRQ pin, LCLK cycles are counted from the start frame of the serialized interrupt transfer cycle generated by the host or a supporting function, and a request signal is generated by the frame corresponding to that interrupt. The timing is shown in figure 16.10.

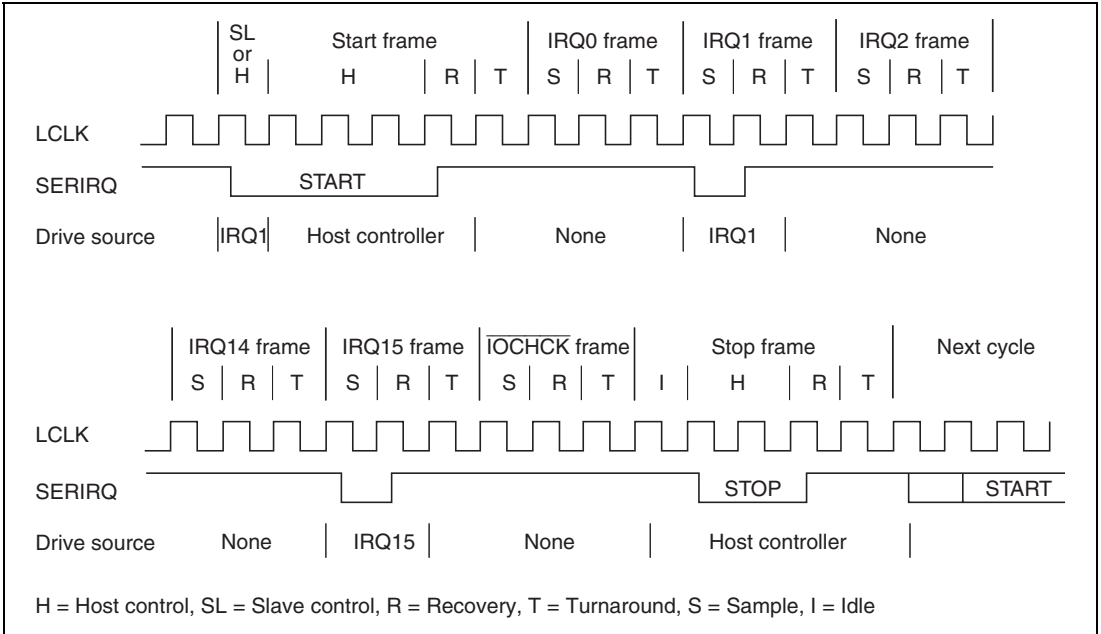

Figure 16.10 SERIRQ Timing

The serialized interrupt transfer cycle frame configuration is as follows. Two of the states comprising each frame are the recover state in which the SERIRQ signal is returned to the 1-level at the end of the frame, and the turnaround state in which the SERIRQ signal is not driven. The recover state must be driven by the host or slave processor that was driving the preceding state.

Table 16.10 Serial Interrupt Transfer Cycle Frame Configuration

Serial Interrupt Transfer Cycle				
Frame Count	Contents	Drive Source	Number of States	Notes
0	Start	Slave Host	6	In quiet mode only, slave drive possible in first state, then next 3 states 0-driven by host
1	IRQ0	Slave	3	
2	IRQ1	Slave	3	Drive possible in LPC channel 1
3	SMI	Slave	3	Drive possible in LPC channels 2 and 3
4	IRQ3	Slave	3	
5	IRQ4	Slave	3	
6	IRQ5	Slave	3	
7	IRQ6	Slave	3	Drive possible in LPC channels 2 and 3
8	IRQ7	Slave	3	
9	IRQ8	Slave	3	
10	IRQ9	Slave	3	Drive possible in LPC channels 2 and 3
11	IRQ10	Slave	3	Drive possible in LPC channels 2 and 3
12	IRQ11	Slave	3	Drive possible in LPC channels 2 and 3
13	IRQ12	Slave	3	Drive possible in LPC channel 1
14	IRQ13	Slave	3	
15	IRQ14	Slave	3	
16	IRQ15	Slave	3	
17	IOCHCK	Slave	3	
18	Stop	Host	Undefined	First, 1 or more idle states, then 2 or 3 states 0-driven by host 2 states: Quiet mode next 3 states: Continuous mode next

There are two modes—continuous mode and quiet mode—for serialized interrupts. The mode initiated in the next transfer cycle is selected by the stop frame of the serialized interrupt transfer cycle that ended before that cycle.

In continuous mode, the host initiates host interrupt transfer cycles at regular intervals. In quiet mode, the slave processor with interrupt sources requiring a request can also initiate an interrupt transfer cycle, in addition to the host. In quiet mode, since the host does not necessarily initiate interrupt transfer cycles, it is possible to suspend the clock (LCLK) supply and enter the power-down state. In order for a slave to transfer an interrupt request in this case, a request to restart the

clock must first be issued to the host. For details see section 16.4.8, LPC Interface Clock Start Request.

16.4.8 LPC Interface Clock Start Request

A request to restart the clock (LCLK) can be sent to the host processor by means of the $\overline{\text{CLKRUN}}$ pin. With LPC data transfer and SERIRQ in continuous mode, a clock restart is never requested since the transfer cycles are initiated by the host. With SERIRQ in quiet mode, when a host interrupt request is generated the $\overline{\text{CLKRUN}}$ signal is driven and a clock (LCLK) restart request is sent to the host. The timing for this operation is shown in figure 16.11.

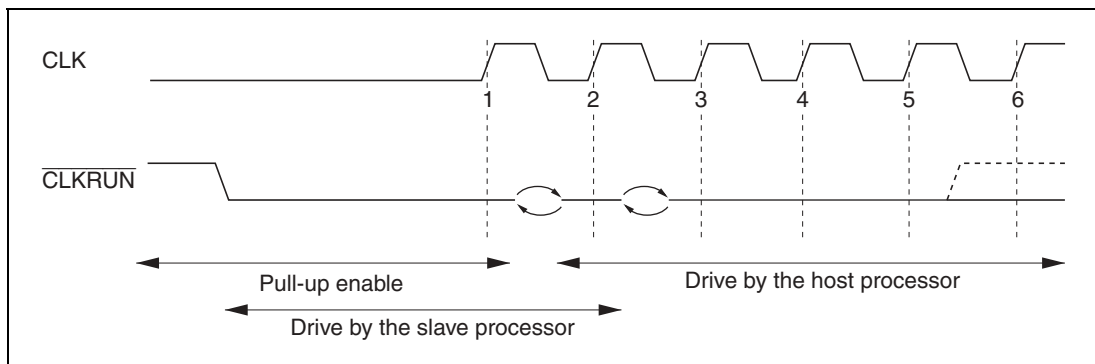

Figure 16.11 Clock Start or Speed-Up

Cases other than SERIRQ in quiet mode when clock restart is required must be handled with a different protocol, using the $\overline{\text{PME}}$ signal, etc.

16.5 Interrupt Sources

16.5.1 IBFI1, IBFI2, IBFI3, ERRI

The LPC interface has four interrupt requests to the slave processor: IBFI1, IBFI2, IBFI3, and ERRI. IBFI1 and IBFI2 are receive complete interrupts for IDR1 and IDR2 respectively. IBFI3 is a receive complete interrupt for IDR3 and TWR, and the interrupt in SMIC mode and BT mode. The ERRI interrupt indicates the occurrence of a special state, such as an LPC reset, LPC shutdown, or transfer cycle abort. An interrupt request is enabled by setting the corresponding enable bit.

Table 16.11 Receive Complete Interrupts and Error Interrupt

Interrupt	Description
IBFI1	Requested when IBFIE1 is set to 1 and IDR1 reception is completed
IBFI2	Requested when IBFIE2 is set to 1 and IDR2 reception is completed
IBFI3	Requested when IBFIE3 is set to 1 and IDR3 reception is completed, or when TWRE and IBFIE3 are set to 1 and reception is completed up to TWR15 Interrupts by HDTWI, HDTRI, STARI, CTLWI, and BUSYI of SMIC mode Interrupts by FRDI, HRDI, HWRI, HBTWI, HBTRI, HRSTI, IRQCRI, BEVTI, B2HI, H2BI, CRRPI, and CRWPI of BT mode
ERRI	Requested when ERRIE is set to 1 and LRST, SDWN, or ABRT is set to 1

16.5.2 SMI, HIRQ1, HIRQ6, HIRQ9, HIRQ10, HIRQ11, HIRQ12

The LPC interface can request seven kinds of host interrupt by means of SERIRQ. HIRQ1 and HIRQ12 are used on LPC channel 1 only, while SMI, HIRQ6, HIRQ9, HIRQ10, and HIRQ11 can be requested from LPC channel 2 or 3.

There are two ways of clearing a host interrupt request.

When the IEDIR bit in SIRQCR0 and the IEDIR3 bit in SIRQCR2 are cleared to 0s, host interrupt sources and LPC channels are all linked to the host interrupt request enable bits. When the OBF flag is cleared to 0 by a read by the host of ODR or TWR15 in the corresponding LPC channel, the corresponding host interrupt enable bit is automatically cleared to 0, and the host interrupt request is cleared.

When the IEDIR bit in SIRQCR0 and the IEDIR3 bit in SIRQCR2 are set to 1s, LPC channel 2 and 3 interrupt requests are dependent only upon the host interrupt enable bits. The host interrupt enable bit is not cleared when OBF for channel 2 or 3 is cleared. Therefore, SMIE2, SMIE3A and SMIE3B, IRQ6E2 and IRQ6E3, IRQ9E2 and IRQ9E3, IRQ10E2 and IRQ10E3, and IRQ11E2 and IRQ11E3 lose their respective functional differences when both bits IEDIR and IEDIR3 are

set to 1. In order to clear a host interrupt request, it is necessary to clear the host interrupt enable bit.

Table 16.12 summarizes the methods of setting and clearing these bits, and figure 16.12 shows the processing flowchart.

Table 16.12 HIRQ Setting and Clearing Conditions

Host Interrupt	Setting Condition	Clearing Condition
HIRQ1	Slave writes to ODR1, then reads 0 from bit IRQ1E1, and writes 1	Slave writes 0 to bit IRQ1E1, or host reads ODR1
HIRQ12	Slave writes to ODR1, then reads 0 from bit IRQ12E1, and writes 1	Slave writes 0 to bit IRQ12E1, or host reads ODR1
SMI (IEDIR = 0)	Slave <ul style="list-style-type: none"> writes to ODR2, then reads 0 from bit SMIE2, and writes 1 	Slave <ul style="list-style-type: none"> writes 0 to bit SMIE2, or host reads ODR2
SMI (IEDIR3 = 0)	Slave <ul style="list-style-type: none"> writes to ODR3, then reads 0 from bit SMIE3A, and writes 1 writes to TWR15, then reads 0 from bit SMIE3B, and writes 1 	Slave <ul style="list-style-type: none"> writes 0 to bit SMIE3A, or host reads ODR3 writes 0 to bit SMIE3B, or host reads TWR15
SMI (IEDIR = 1)	Slave <ul style="list-style-type: none"> reads 0 from bit SMIE2, then writes 1 	Slave writes 0 to bit SMIE2
SMI (IEDIR3 = 1)	Slave <ul style="list-style-type: none"> reads 0 from bit SMIE3A, then writes 1 reads 0 from bit SMIE3B, then writes 1 	Slave <ul style="list-style-type: none"> writes 0 to bit SMIE3A writes 0 to bit SMIE3B
HIRQi (i = 6, 9, 10, 11) (IEDIR = 0)	Slave <ul style="list-style-type: none"> writes to ODR2, then reads 0 from bit IRQiE2, and writes 1 	Slave <ul style="list-style-type: none"> writes 0 to bit IRQiE2, or host reads ODR2
HIRQi (i = 6, 9, 10, 11) (IEDIR3 = 0)	Slave <ul style="list-style-type: none"> writes to ODR3, then reads 0 from bit IRQiE3 and writes 1 	Slave <ul style="list-style-type: none"> writes 0 to bit IRQiE3, or host reads ODR3
HIRQi (i = 6, 9, 10, 11) (IEDIR = 1)	Slave <ul style="list-style-type: none"> reads 0 from bit IRQiE2, then writes 1 	Slave <ul style="list-style-type: none"> writes 0 to bit IRQiE2
HIRQi (i = 6, 9, 10, 11) (IEDIR3 = 1)	Slave <ul style="list-style-type: none"> reads 0 from bit IRQiE3, then writes 1 	Slave <ul style="list-style-type: none"> writes 0 to bit IRQiE3

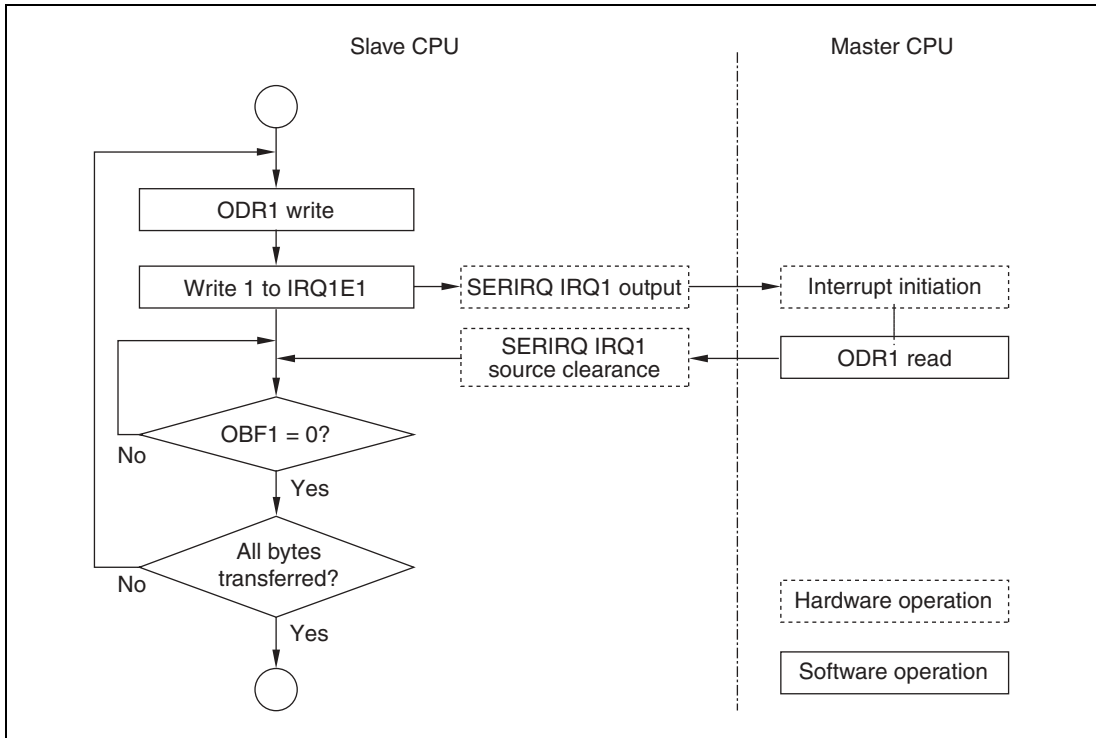

Figure 16.12 HIRQ Flowchart (Example of Channel 1)

16.6 Usage Notes

16.6.1 Module Stop Setting

The LPC operation stop or enable can be specified by the module stop control register. With the initial value, LPC operation will stop. Releasing module stop mode enables access to the register. For details see section 23, Power-Down Modes.

16.6.2 Usage Note of LPC Interface

The LPC interface provides buffering of asynchronous data from the host processor and slave processor (this LSI), but an interface protocol that uses the flags in STR is required to avoid data contention. For example, if the host and slave processor both try to access IDR or ODR at the same time, the data will be corrupted. To prevent simultaneous accesses, IBF and OBF must be used to allow access only to data for which writing has finished.

Unlike the IDR and ODR registers, the transfer direction is not fixed for the bidirectional data registers (TWR). MWMF and SWMF are provided in STR to handle this situation. After writing to TWR0, MWMF and SWMF must be used to confirm that the right to access TWR1 to TWR15 has been obtained.

Table 16.13 shows the host address example of registers LADR3, IDR3, ODR3, STR3, TWR0MW, TWR0SW, and TWR1 to TWR15.

Table 16.13 Host Addresses Example

Register	Host Address When LADR3 = H'A24F	Host Address When LADR3 = H'3FD0
IDR3	H'A24A and H'A24E	H'3FD0 and H'3FD4
ODR3	H'A24A	H'3FD0
STR3	H'A24E	H'3FD4
TWR0MW	H'A250	H'3FC0
TWR0SW	H'A250	H'3FC0
TWR1	H'A251	H'3FC1
TWR2	H'A252	H'3FC2
TWR3	H'A253	H'3FC3
TWR4	H'A254	H'3FC4
TWR5	H'A255	H'3FC5
TWR6	H'A256	H'3FC6
TWR7	H'A257	H'3FC7
TWR8	H'A258	H'3FC8
TWR9	H'A259	H'3FC9
TWR10	H'A25A	H'3FCA
TWR11	H'A25B	H'3FCB
TWR12	H'A25C	H'3FCC
TWR13	H'A25D	H'3FCD
TWR14	H'A25E	H'3FCE
TWR15	H'A25F	H'3FCF

Section 17 D/A Converter

17.1 Features

- 8-bit resolution
- Two output channels
- Conversion time: Max. 10 μ s (when load capacitance is 20 pF)
- Output voltage: 0 V to AVref
- D/A output retaining function in software standby mode

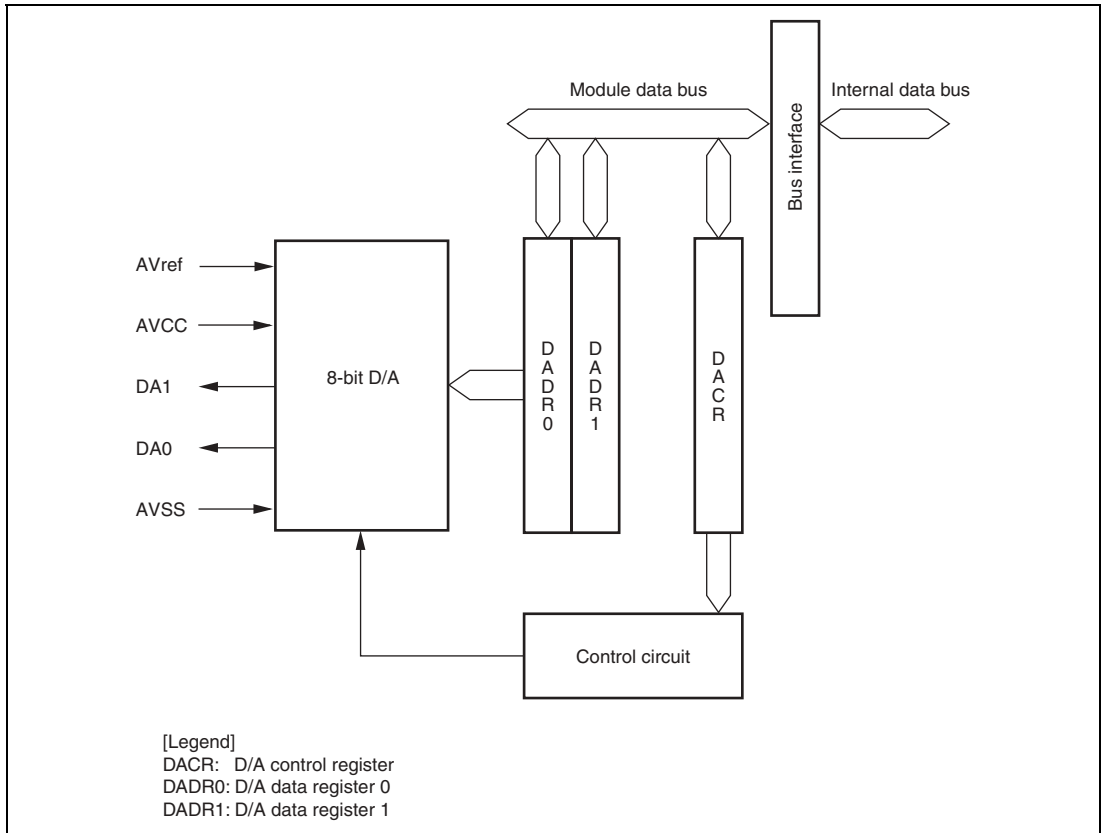

Figure 17.1 Block Diagram of D/A Converter

17.2 Input/Output Pins

Table 17.1 summarizes the input/output pins used by the D/A converter.

Table 17.1 Pin Configuration

Pin Name	Symbol	I/O	Function
Analog power supply pin	AVCC	Input	Analog block power supply
Analog ground pin	AVSS	Input	Analog block ground and reference voltage
Analog output pin 0	DA0	Output	Channel 0 analog output
Analog output pin 1	DA1	Output	Channel 1 analog output
Reference power supply pin	AVref	Input	Analog block reference voltage

17.3 Register Descriptions

The D/A converter has the following registers.

- D/A data register 0 (DADR0)
- D/A data register 1 (DADR1)
- D/A control register (DACR)

17.3.1 D/A Data Registers 0 and 1 (DADR0, DADR1)

DADR0 and DADR1 are 8-bit readable/writable registers that store data for D/A conversion. When analog output is permitted, D/A data register contents are converted and output to analog output pins.

17.3.2 D/A Control Register (DACR)

DACR controls D/A converter operation.

Bit	Bit Name	Initial Value	R/W	Description
7	DAOE1	0	R/W	D/A Output Enable 1 Controls D/A conversion and analog output. 0: Analog output DA1 is disabled 1: D/A conversion for channel 1 and analog output DA1 are enabled
6	DAOE0	0	R/W	D/A Output Enable 0 Controls D/A conversion and analog output. 0: Analog output DA0 is disabled 1: D/A conversion for channel 0 and analog output DA0 are enabled
5	DAE	0	R/W	D/A Enable Controls D/A conversion in conjunction with the DAOE0 and DAOE1 bits. When the DAE bit is cleared to 0, D/A conversion for channels 0 and 1 are controlled individually. When the DAE bit is set to 1, D/A conversion for channels 0 and 1 are controlled as one. Conversion result output is controlled by the DAOE0 and DAOE1 bits. For details, see table 17.2 below.
4 to 0	—	All 1	R	Reserved The initial value should not be changed.

Table 17.2 D/A Channel Enable

Bit 7	Bit 6	Bit 5	Description
0	0	*	Disables D/A conversion
		0	Enables D/A conversion for channel 0
	1	0	Disables D/A conversion for channel 1
		1	Enables D/A conversion for channels 0 and 1
1	0	0	Disables D/A conversion for channel 0
		0	Enables D/A conversion for channel 1
		1	Enables D/A conversion for channels 0 and 1
	1	*	Enables D/A conversion for channels 0 and 1

[Legend]

*: Don't care

17.4 Operation

The D/A converter incorporates two channels of the D/A circuits and can be converted individually.

When the DAOE bit in DACR is set to 1, D/A conversion is enabled and conversion results are output.

An example of D/A conversion of channel 0 is shown below. The operation timing is shown in figure 17.2.

1. Write conversion data to DADR0.
2. When the DAOE0 bit in DACR is set to 1, D/A conversion starts. After the interval of t_{DCONV} , conversion results are output from the analog output pin DA0. The conversion results are output continuously until DADR0 is modified or the DAOE0 bit is cleared to 0. The output value is calculated by the following formula:

$$\text{DADR contents}/256 \times \text{AVref}$$

3. Conversion starts immediately after DADR0 is modified. After the interval of t_{DCONV} , conversion results are output.
4. When the DAOE bit is cleared to 0, analog output is disabled.

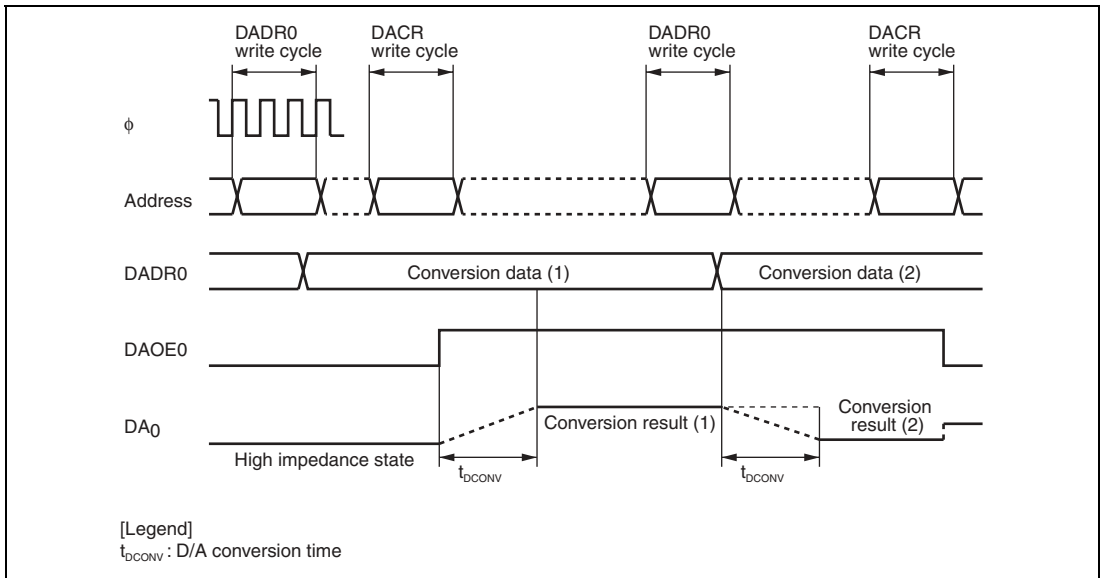

Figure 17.2 D/A Converter Operation Example

17.5 Usage Note

When this LSI enters software standby mode with D/A conversion enabled, the D/A output is retained, and the analog power supply current is equal to as during D/A conversion. If the analog power supply current needs to be reduced in software standby mode, clear the DAOE1, DAOE0, and DAE bits all to 0 to disable D/A output.

Section 18 A/D Converter

This LSI includes a successive-approximation-type 10-bit A/D converter that allows up to eight analog input channels to be selected.

18.1 Features

- 10-bit resolution
- Input channels: eight analog input channels
- Analog conversion voltage range can be specified using the reference power supply voltage pin (AVref) as an analog reference voltage.
- Conversion time: 8.06 μ s per channel (at 33-MHz operation)
- Two kinds of operating modes
 - Single mode: Single-channel A/D conversion
 - Scan mode: Continuous A/D conversion on 1 to 4 channels
- Four data registers
 - Conversion results are held in a 16-bit data register for each channel
- Sample and hold function
- Three kinds of conversion start
 - Software, 8-bit timer (TMR) conversion start trigger, or external trigger signal.
- Interrupt request
 - A/D conversion end interrupt (ADI) request can be generated
- Module stop mode can be set

18.1.1 Block Diagram

A block diagram of the A/D converter is shown in figure 18.1.

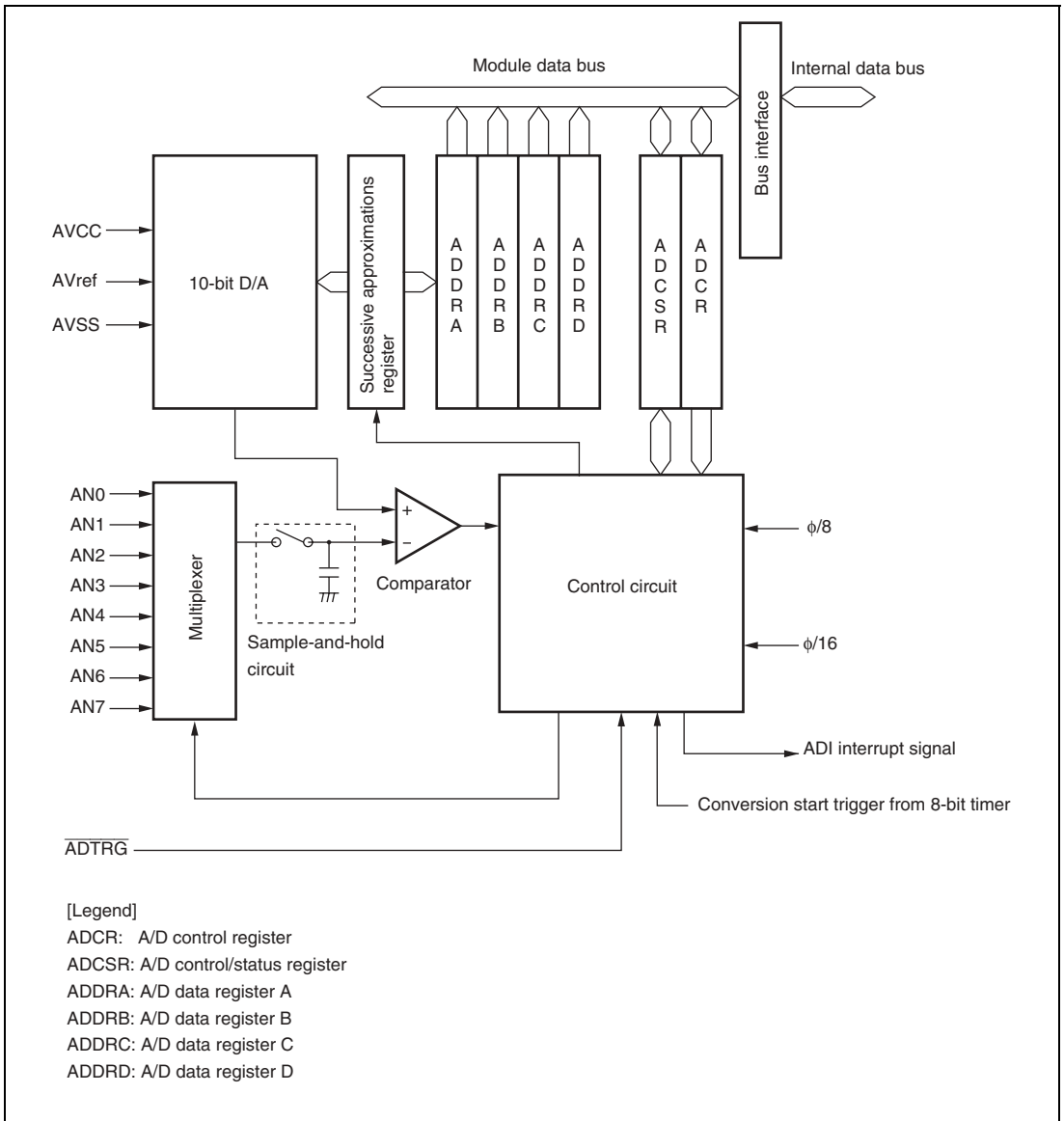

Figure 18.1 Block Diagram of A/D Converter

18.2 Input/Output Pins

Table 18.1 summarizes the pins used by the A/D converter. The 8 analog input pins are divided into two groups consisting of four channels. Analog input pins 0 to 3 (AN0 to AN3) comprising group 0 and analog input pins 4 to 7 (AN4 to AN7) comprising group1.

The AVCC and AVSS pins are the power supply pins for the analog block in the A/D converter.

Table 18.1 Pin Configuration

Pin Name	Symbol	I/O	Function
Analog power supply pin	AVCC	Input	Analog block power supply
Analog ground pin	AVSS	Input	Analog block ground and reference voltage
Reference power supply pin	AVref	Input	Reference voltage for A/D conversion
Analog input pin 0	AN0	Input	Group 0 analog input pins
Analog input pin 1	AN1	Input	
Analog input pin 2	AN2	Input	
Analog input pin 3	AN3	Input	
Analog input pin 4	AN4	Input	Group 1 analog input pins
Analog input pin 5	AN5	Input	
Analog input pin 6	AN6	Input	
Analog input pin 7	AN7	Input	
A/D external trigger input pin	$\overline{\text{ADTRG}}$	Input	External trigger input pin for starting A/D conversion

18.3 Register Descriptions

The A/D converter has the following registers.

- A/D data register A (ADDRA)
- A/D data register B (ADDRB)
- A/D data register C (ADDRC)
- A/D data register D (ADDRD)
- A/D control/status register (ADCSR)
- A/D control register (ADCR)

18.3.1 A/D Data Registers A to D (ADDRA to ADDR D)

There are four 16-bit read-only ADDR registers, ADDRA to ADDR D, used to store the results of A/D conversion. The ADDR registers, which store a conversion result for each channel, are shown in table 18.2.

The converted 10-bit data is stored to bits 15 to 6. The lower 6-bit data is always read as 0.

The data bus between the CPU and the A/D converter is 8-bit width. The upper byte can be read directly from the CPU, but the lower byte should be read via a temporary register. The temporary register contents are transferred from the ADDR when the upper byte data is read. When reading the ADDR, read only the upper byte in byte units or read in word units.

Table 18.2 Analog Input Channels and Corresponding ADDR Registers

Analog Input Channel		A/D Data Register to Store A/D Conversion Results
Group 0	Group 1	
AN0	AN4	ADDRA
AN1	AN5	ADDRB
AN2	AN6	ADDRC
AN3	AN7	ADDRD

18.3.2 A/D Control/Status Register (ADCSR)

ADCSR controls A/D conversion operations.

Bit	Bit Name	Initial Value	R/W	Description
7	ADF	0	R/(W)*	<p>A/D End Flag</p> <p>A status flag that indicates the end of A/D conversion.</p> <p>[Setting conditions]</p> <ul style="list-style-type: none">• When A/D conversion ends in single mode• When A/D conversion ends on all channels specified in scan mode <p>[Clearing conditions]</p> <ul style="list-style-type: none">• When 0 is written after reading ADF = 1• When DTC starts by an ADI interrupt and ADDR is read
6	ADIE	0	R/W	<p>A/D Interrupt Enable</p> <p>Enables ADI interrupt by ADF when this bit is set to 1</p>
5	ADST	0	R/W	<p>A/D Start</p> <p>Setting this bit to 1 starts A/D conversion. In single mode, this bit is cleared to 0 automatically when conversion on the specified channel ends. In scan mode, conversion continues sequentially on the specified channels until this bit is cleared to 0 by software, a reset, or a transition to standby mode or module stop mode.</p>
4	SCAN	0	R/W	<p>Scan Mode</p> <p>Selects the A/D conversion operating mode.</p> <p>0: Single mode</p> <p>1: Scan mode</p>
3	CKS	0	R/W	<p>Clock Select</p> <p>Sets A/D conversion time.</p> <p>0: Conversion time is 266 states (max)</p> <p>1: Conversion time is 134 states (max) (when the system clock (ϕ) is 16 MHz or lower)</p> <p>Switch conversion time while ADST is 0.</p>

Bit	Bit Name	Initial Value	R/W	Description
2	CH2	All 0	R/W	Channel Select 2 to 0
1	CH1			Select analog input channels.
0	CH0			When SCAN = 0
				When SCAN = 1
				000: AN0
				001: AN1
				010: AN2
				011: AN3
				100: AN4
				101: AN5
				110: AN6
				111: AN7

Note: * Only 0 can be written for clearing the flag.

18.3.3 A/D Control Register (ADCR)

ADCR enables A/D conversion started by an external trigger signal.

Bit	Bit Name	Initial Value	R/W	Description
7	TRGS1	0	R/W	Timer Trigger Select 1 and 0
6	TRGS0	0	R/W	Enable the start of A/D conversion by a trigger signal. Only set bits TRGS1 and TRGS0 while A/D conversion is stopped (ADST = 0).
				00: A/D conversion start by external trigger is disabled
				01: A/D conversion start by external trigger is disabled
				10: A/D conversion start by conversion trigger from TMR
				11: A/D conversion start by $\overline{\text{ADTRG}}$ pin
5 to 0	—	All 1	R/W	Reserved
				The initial values should not be changed.

18.4 Operation

The A/D converter operates by successive approximation with 10-bit resolution. It has two operating modes: single mode and scan mode. When changing the operating mode or analog input channel, to prevent incorrect operation, first clear the ADST bit to 0 in ADCSR to halt A/D conversion. The ADST bit can be set at the same time as the operating mode or analog input channel is changed.

18.4.1 Single Mode

In single mode, A/D conversion is to be performed only once on the specified single channel. Operations are as follows.

1. A/D conversion on the specified channel is started when the ADST bit in ADCSR is set to 1, by software or an external trigger input.
2. When A/D conversion is completed, the result is transferred to the A/D data register corresponding to the channel.
3. On completion of A/D conversion, the ADF bit in ADCSR is set to 1. If the ADIE bit is set to 1 at this time, an ADI interrupt request is generated.
4. The ADST bit remains set to 1 during A/D conversion. When conversion ends, the ADST bit is automatically cleared to 0, and the A/D converter enters wait state.

18.4.2 Scan Mode

In scan mode, A/D conversion is to be performed sequentially on the specified channels (four channels max.). Operations are as follows.

1. When the ADST bit in ADCSR is set to 1 by software or an external trigger input, A/D conversion starts on the first channel in the group (AN0 when the CH2 bit in ADCSR is 0, or AN4 when the CH2 bit in ADCSR is 1).
2. When A/D conversion for each channel is completed, the result is sequentially transferred to the A/D data register corresponding to each channel.
3. When conversion of all the selected channels is completed, the ADF bit in ADCSR is set to 1. If the ADIE bit is set to 1 at this time, an ADI interrupt is requested after A/D conversion ends. Conversion of the first channel in the group starts again.
4. The ADST bit is not automatically cleared to 0 so steps [2] to [3] are repeated as long as the ADST bit remains set to 1. When the ADST bit is cleared to 0, A/D conversion stops.

18.4.3 Input Sampling and A/D Conversion Time

The A/D converter has a built-in sample-and-hold circuit. The A/D converter samples the analog input when the A/D conversion start delay time (t_D) passes after the ADST bit in ADCSR is set to 1, then starts A/D conversion. Figure 18.2 shows the A/D conversion timing. Table 18.3 indicates the A/D conversion time.

As indicated in figure 18.2, the A/D conversion time (t_{CONV}) includes t_D and the input sampling time (t_{SPL}). The length of t_D varies depending on the timing of the write access to ADCSR. The total conversion time therefore varies within the ranges indicated in table 18.3.

In scan mode, the values given in table 18.3 apply to the first conversion time. In the second and subsequent conversions, the conversion time is 266 states (fixed) when CKS = 0 and 134 states (fixed) when CKS = 1.

Use the conversion time of 134 state only when the system clock (ϕ) is 16 MHz or lower.

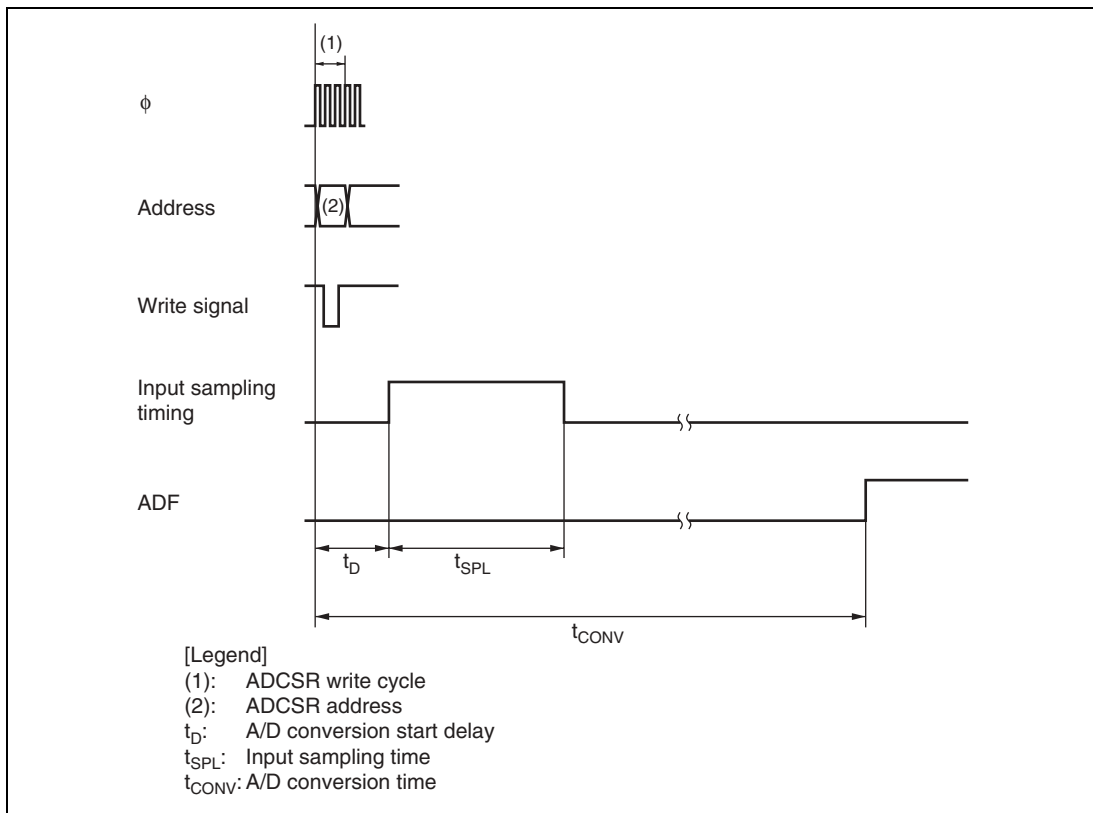

Figure 18.2 A/D Conversion Timing

Table 18.3 A/D Conversion Time (Single Mode)

Item	Symbol	CKS = 0			CKS = 1*		
		min	typ	max	min	typ	max
A/D conversion start delay time	t_d	10	—	17	6	—	9
Input sampling time	t_{SPL}	—	63	—	—	31	—
A/D conversion time	t_{CONV}	259	—	266	131	—	134

Notes: Values in the table indicate the number of states.

* in the table indicates that the system clock (ϕ) is 16 MHz or lower.

18.4.4 External Trigger Input Timing

A/D conversion can be externally triggered. When the TRGS1 and TRGS0 bits are set to B'11 in ADCR, external trigger input is enabled at the \overline{ADTRG} pin. A falling edge at the \overline{ADTRG} pin sets the ADST bit to 1 in ADCSR, starting A/D conversion. Other operations, in both single and scan modes, are the same as when the ADST bit has been set to 1 by software. Figure 18.3 shows the timing.

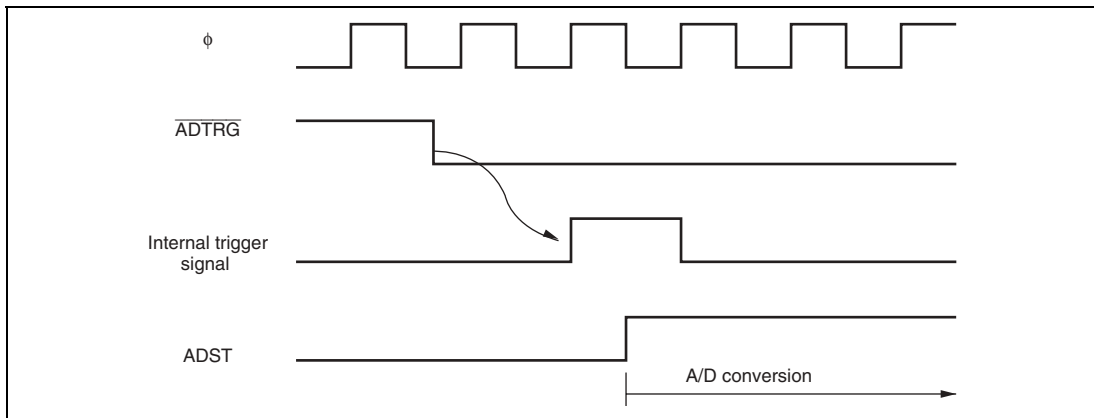

Figure 18.3 External Trigger Input Timing

18.5 Interrupt Source

The A/D converter generates an A/D conversion end interrupt (ADI) at the end of A/D conversion. Setting the ADIE bit to 1 enables ADI interrupt requests while the ADF bit in ADCSR is set to 1 after A/D conversion ends.

The ADI interrupt can be used as a DTC activation interrupt source.

Table 18.4 A/D Converter Interrupt Source

Name	Interrupt Source	Interrupt Flag	DTC Activation
ADI	A/D conversion end	ADF	Possible

18.6 A/D Conversion Accuracy Definitions

This LSI's A/D conversion accuracy definitions are given below.

- Resolution
The number of A/D converter digital output codes
- Quantization error
The deviation inherent in the A/D converter, given by 1/2 LSB (see figure 18.4).
- Offset error
The deviation of the analog input voltage value from the ideal A/D conversion characteristic when the digital output changes from the minimum voltage value B'00 0000 0000 (H'000) to B'00 0000 0001 (H'001) (see figure 18.5).
- Full-scale error
The deviation of the analog input voltage value from the ideal A/D conversion characteristic when the digital output changes from B'11 1111 1110 (H'3FE) to B'11 1111 1111 (H'3FF) (see figure 18.5).
- Nonlinearity error
The error with respect to the ideal A/D conversion characteristics between the zero voltage and the full-scale voltage. Does not include the offset error, full-scale error, or quantization error (see figure 18.5).
- Absolute accuracy
The deviation between the digital value and the analog input value. Includes the offset error, full-scale error, quantization error, and nonlinearity error.

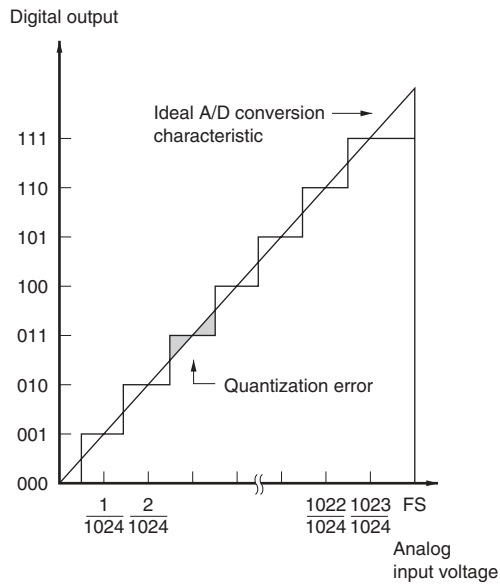

Figure 18.4 A/D Conversion Accuracy Definitions

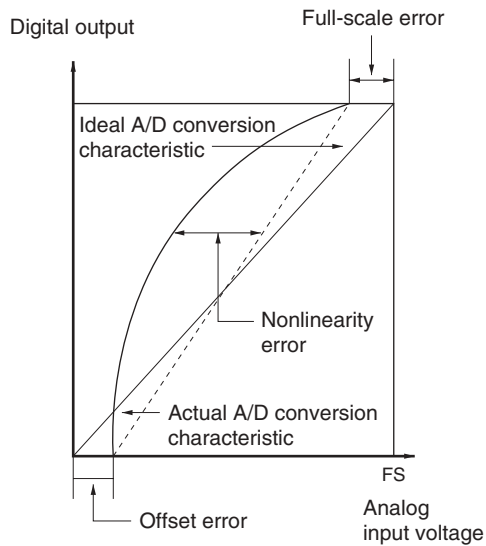

Figure 18.5 A/D Conversion Accuracy Definitions

18.7 Usage Notes

18.7.1 Permissible Signal Source Impedance

This LSI's analog input is designed so that the conversion accuracy is guaranteed for an input signal for which the signal source impedance is $5\text{ k}\Omega$ or less. This specification is provided to enable the A/D converter's sample-and-hold circuit input capacitance to be charged within the sampling time; if the sensor output impedance exceeds $10\text{ k}\Omega$, charging may be insufficient and it may not be possible to guarantee the A/D conversion accuracy. However, if a large capacitance is provided externally in single mode, the input load will essentially comprise only the internal input resistance of $10\text{ k}\Omega$, and the signal source impedance is ignored. However, since a low-pass filter effect is obtained in this case, it may not be possible to follow an analog signal with a large differential coefficient (e.g., voltage fluctuation ratio of $5\text{ mV}/\mu\text{s}$ or greater) (see figure 18.6). When converting a high-speed analog signal or converting in scan mode, a low-impedance buffer should be inserted.

18.7.2 Influences on Absolute Accuracy

Adding capacitance results in coupling with GND, and therefore noise in GND may adversely affect the absolute accuracy. Be sure to make the connection to an electrically stable GND such as AVSS.

Care is also required to insure that filter circuits do not communicate with digital signals on the mounting board, so acting as antennas.

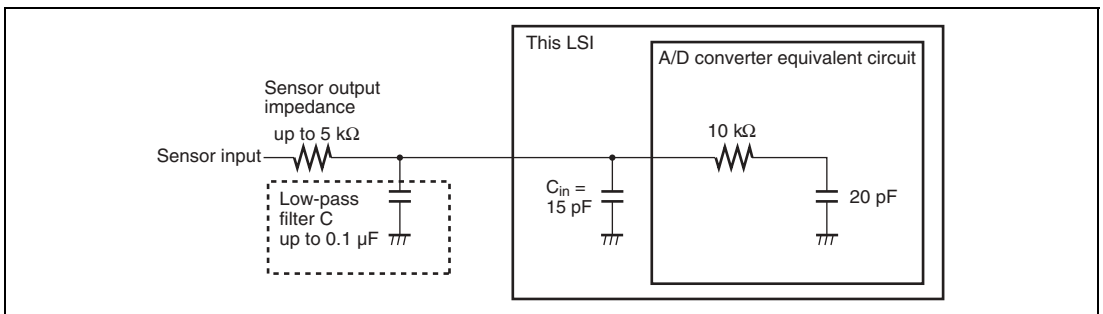

Figure 18.6 Example of Analog Input Circuit

18.7.3 Setting Range of Analog Power Supply and Other Pins

If conditions shown below are not met, the reliability of this LSI may be adversely affected.

- Analog input voltage range
The voltage applied to analog input pin ANn during A/D conversion should be in the range $AVSS \leq ANn \leq AVref$ ($n = 0$ to 7).
- Relation between AVCC, AVSS and VCC, VSS
For the relationship between AVCC, AVSS and VCC, VSS, set $AVSS = VSS$, and $AVCC = VCC$ is not always necessary. If the A/D converter is not used, the AVCC and AVSS pins must on no account be left open.
- AVref pin reference voltage specification range
The reference voltage of the AVref pin should be in the range $AVref \leq AVCC$.

18.7.4 Notes on Board Design

In board design, digital circuitry and analog circuitry should be as mutually isolated as possible, and layout in which digital circuit signal lines and analog circuit signal lines cross or are in close proximity should be avoided as far as possible. Failure to do so may result in incorrect operation of the analog circuitry due to inductance, adversely affecting A/D conversion values. Also, digital circuitry must be isolated from the analog input signals (AN0 to AN7), and analog power supply (AVCC) by the analog ground (AVSS). Also, the analog ground (AVSS) should be connected at one point to a stable digital ground (VSS) on the board.

18.7.5 Notes on Noise Countermeasures

A protection circuit connected to prevent damage due to an abnormal voltage such as an excessive surge at the analog input pins (AN0 to AN7) should be connected between AVCC and AVSS as shown in figure 18.7. Also, the bypass capacitors connected to AVCC and AVref, and the filter capacitors connected to AN0 to AN7 must be connected to AVSS.

If a filter capacitor is connected, the input currents at the analog input pins (AN0 to AN7) are averaged, and so an error may arise. Also, when A/D conversion is performed frequently, as in scan mode, if the current charged and discharged by the capacitance of the sample-and-hold circuit in the A/D converter exceeds the current input via the input impedance (R_{in}), an error will arise in the analog input pin voltage. Careful consideration is therefore required when deciding the circuit constants.

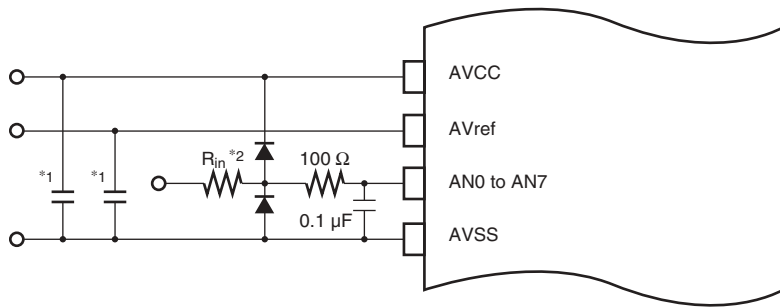

Notes: Values are reference values.

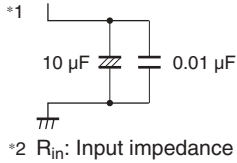
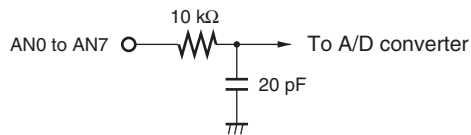

Figure 18.7 Example of Analog Input Protection Circuit



Note: Values are reference values.

Figure 18.8 Analog Input Pin Equivalent Circuit

Section 19 RAM

This LSI has 40 kbytes of on-chip high-speed static RAM. The RAM is connected to the CPU by a 16-bit data bus, enabling one-state access by the CPU to both byte data and word data.

The on-chip RAM can be enabled or disabled by means of the RAME bit in the system control register (SYSCR). For details on SYSCR, see section 3.2.2, System Control Register (SYSCR).

Section 20 Flash Memory (0.18- μ m F-ZTAT Version)

The flash memory has the following features. Figure 20.1 shows a block diagram of the flash memory.

20.1 Features

- Size

Product Classification		ROM Size	ROM Address
H8S/2168	HD64F2168	256 kbytes	H'000000 to H'03FFFF
H8S/2167	HD64F2167	384 kbytes	H'000000 to H'05FFFF
H8S/2166	HD64F2166	512 kbytes	H'000000 to H'07FFFF

- Two flash-memory MATs according to LSI initiation mode
The on-chip flash memory has two memory spaces in the same address space (hereafter referred to as memory MATs). The mode setting in the initiation determines which memory MAT is initiated first. The MAT can be switched by using the bank-switching method after initiation.
 - The user memory MAT is initiated at a power-on reset in user mode: 256 kbytes (H8S/2168), 384 kbytes (H8S/2167), 512 kbytes (H8S/2166)
 - The user boot memory MAT is initiated at a power-on reset in user boot mode: 8 kbytes
- Programming/erasing interface by the download of on-chip program
This LSI has a dedicated programming/erasing program. After downloading this program to the on-chip RAM, programming/erasing can be performed by setting the argument parameter.
- Programming/erasing time
The flash memory programming time is 3 ms (typ) in 128-byte simultaneous programming and approximately 25 μ s per byte. The erasing time is 1000 ms (typ) per 64-kbyte block.
- Number of programming
The number of flash memory programming can be up to 100 times at the minimum. (The value ranged from 1 to 100 is guaranteed.)
- Three on-board programming modes
 - Boot mode
This mode is a program mode that uses an on-chip SCI interface. The user MAT and user boot MAT can be programmed. This mode can automatically adjust the bit rate between host and this LSI.
 - User program mode
The user MAT can be programmed by using the optional interface.

— User boot mode

The user boot program of the optional interface can be made and the user MAT can be programmed.

- Programming/erasing protection

Sets protection against flash memory programming/erasing via hardware, software, or error protection.

- Programmer mode

This mode uses the PROM programmer. The user MAT and user boot MAT can be programmed.

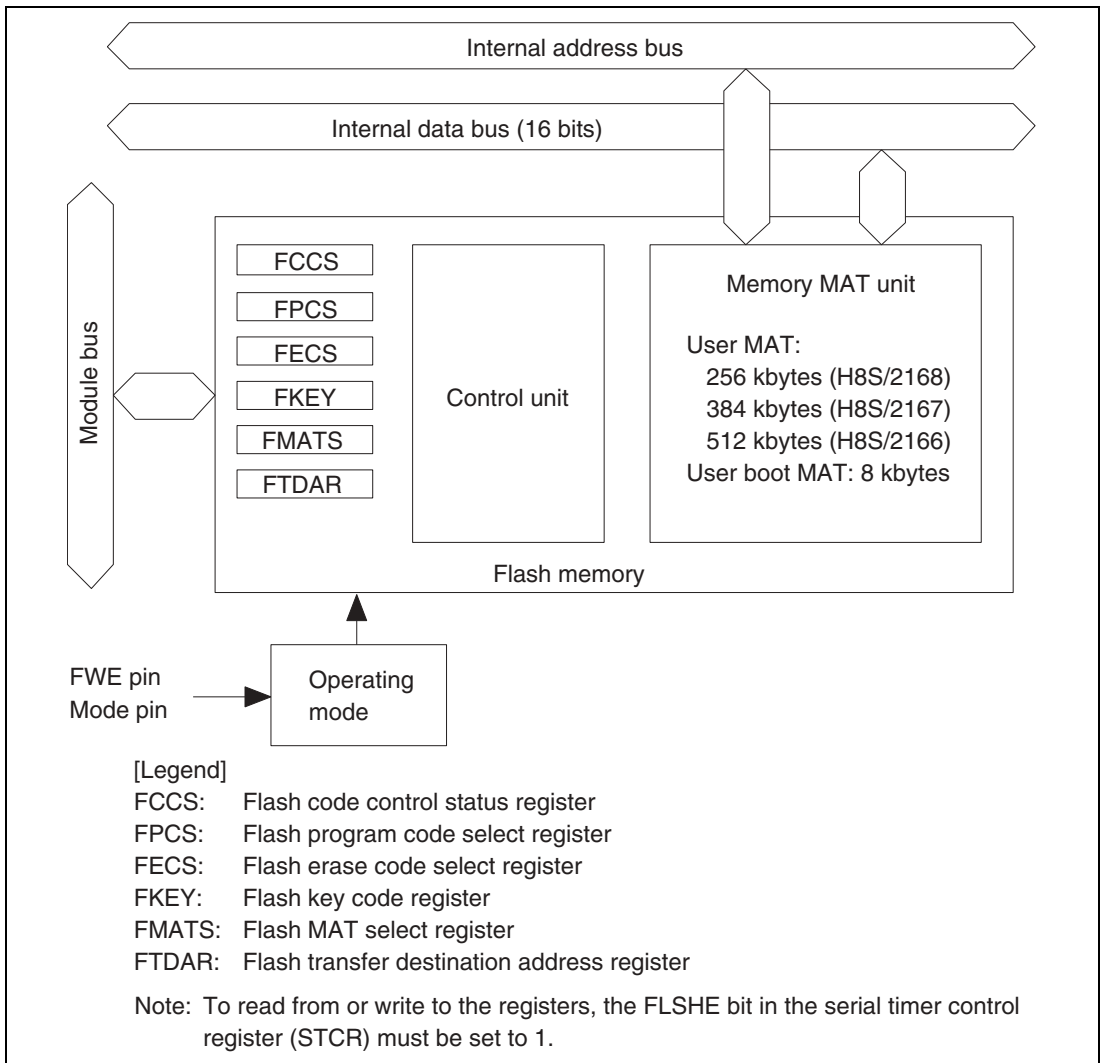

Figure 20.1 Block Diagram of Flash Memory

20.1.1 Operating Mode

When each mode pin and the FWE pin are set in the reset state and reset start is performed, this LSI enters each operating mode as shown in figure 20.2.

- Flash memory can be read in user mode, but cannot be programmed or erased.
- Flash memory can be read, programmed, or erased on the board only in boot mode, user program mode, and user boot mode.
- Flash memory can be read, programmed, or erased by means of the PROM programmer in programmer mode.

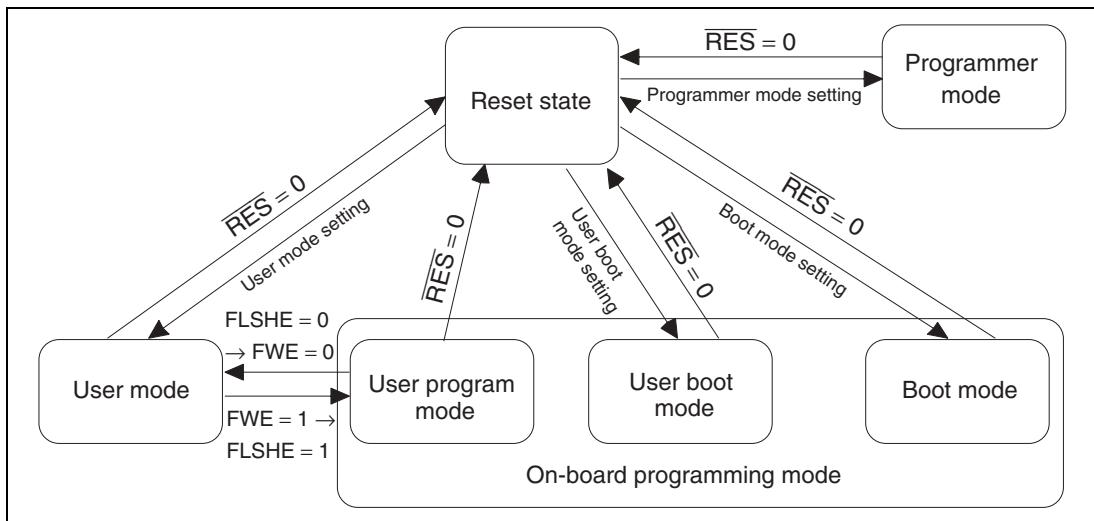

Figure 20.2 Mode Transition of Flash Memory

20.1.2 Mode Comparison

The comparison table of programming and erasing related items about boot mode, user program mode, user boot mode, and programmer mode is shown in table 20.1.

Table 20.1 Comparison of Programming Modes

	Boot mode	User program mode	User boot mode	Programmer mode
Programming/erasing environment	On-board	On-board	On-board	PROM programmer
Programming/erasing enable MAT	User MAT User boot MAT	User MAT	User MAT	User MAT User boot MAT
All erasure	○ (Automatic)	○	○	○ (Automatic)
Block division erasure	○ * ¹	○	○	×
Program data transfer	From host via SCI	Via optional device	Via optional device	Via programmer
Reset initiation MAT	Embedded program storage MAT	User MAT	User boot MAT* ²	—
Transition to user mode	Changing mode setting and reset	Changing FLSHE bit and FWE pin	Changing mode setting and reset	—

Notes: 1. All-erasure is performed. After that, the specified block can be erased.

2. Firstly, the reset vector is fetched from the embedded program storage MAT. After the flash memory related registers are checked, the reset vector is fetched from the user boot MAT.

- The user boot MAT can be programmed or erased only in boot mode and programmer mode.
- The user MAT and user boot MAT are erased in boot mode. Then, the user MAT and user boot MAT can be programmed by means of the command method. However, the contents of the MAT cannot be read until this state.
Only user boot MAT is programmed and the user MAT is programmed in user boot mode or only user MAT is programmed because user boot mode is not used.
- The boot operation of the optional interface can be performed by the mode pin setting different from user program mode in user boot mode.

20.1.3 Flash Memory MAT Configuration

This LSI's flash memory is configured by the 8-kbyte user boot MAT and 256-kbyte (H8S/2168), 384-kbyte (H8S/2167), or 512-kbytes (H8S/2166) user MAT.

The start address is allocated to the same address in the user MAT and user boot MAT. Therefore, when the program execution or data access is performed between two MATs, the MAT must be switched by using FMATS.

The user MAT or user boot MAT can be read in all modes. However, the user boot MAT can be programmed only in boot mode and programmer mode.

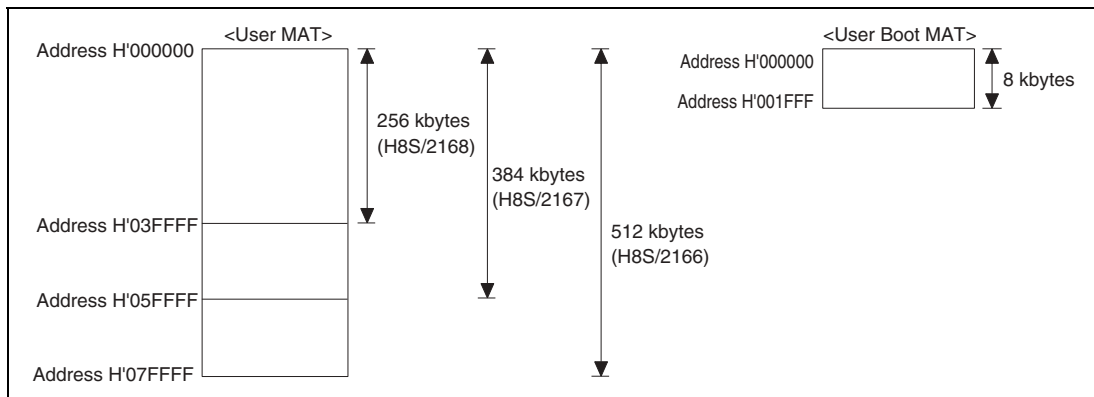

Figure 20.3 Flash Memory Configuration

The size of the user MAT is different from that of the user boot MAT. An address which exceeds the size of the 8-kbyte user boot MAT should not be accessed. If the attempt is made, data is read as undefined value.

20.1.4 Block Division

The user MAT is divided into 64 kbytes (three blocks for H8S/2168, five blocks for H8S/2167, seven blocks for H8S/2166), 32 kbytes (one block), and 4 kbytes (eight blocks) as shown in figure 20.4. The user MAT can be erased in this divided-block units and the erase-block number of EB0 to EB15 is specified when erasing.

EB0	H'000000	H'000001	H'000002	←Programming unit: 128 bytes→	H'00007F
Erase unit: 4 kbytes	H'000F80	H'000F81	H'000F82	-----	H'000FFF
EB1	H'001000	H'001001	H'001002	←Programming unit: 128 bytes→	H'00107F
Erase unit: 4 kbytes	H'001F80	H'001F81	H'001F82	-----	H'001FFF
EB2	H'002000	H'002001	H'002002	←Programming unit: 128 bytes→	H'00207F
Erase unit: 4 kbytes	H'002F80	H'002F81	H'002F82	-----	H'002FFF
EB3	H'003000	H'003001	H'003002	←Programming unit: 128 bytes→	H'00307F
Erase unit: 4 kbytes	H'003F80	H'003F81	H'003F82	-----	H'003FFF
EB4	H'004000	H'004001	H'004002	←Programming unit: 128 bytes→	H'00407F
Erase unit: 32 kbytes	H'00BF80	H'00BF81	H'00BF82	-----	H'00BFFF
EB5	H'00C000	H'00C001	H'00C002	←Programming unit: 128 bytes→	H'00C07F
Erase unit: 4 kbytes	H'00CF80	H'00CF81	H'00CF82	-----	H'00CFFF
EB6	H'00D000	H'00D001	H'00D002	←Programming unit: 128 bytes→	H'00D07F
Erase unit: 4 kbytes	H'00DF80	H'00DF81	H'00DF82	-----	H'00DFFF
EB7	H'00E000	H'00E001	H'00E002	←Programming unit: 128 bytes→	H'00E07F
Erase unit: 4 kbytes	H'00EF80	H'00EF81	H'00EF82	-----	H'00EFFF
EB8	H'00F000	H'00F001	H'00F002	←Programming unit: 128 bytes→	H'00F07F
Erase unit: 4 kbytes	H'00FF80	H'00FF81	H'00FF82	-----	H'00FFFF
EB9	H'010000	H'010001	H'010002	←Programming unit: 128 bytes→	H'01007F
Erase unit: 64 kbytes	H'01FF80	H'01FF81	H'01FF82	-----	H'01FFFF
EB10	H'020000	H'020001	H'020002	←Programming unit: 128 bytes→	H'02007F
Erase unit: 64 kbytes	H'02FF80	H'02FF81	H'02FF82	-----	H'02FFFF
EB11	H'030000	H'030001	H'030002	←Programming unit: 128 bytes→	H'03007F
Erase unit: 64 kbytes	H'03FF80	H'03FF81	H'03FF82	-----	H'03FFFF
EB12*1	H'040000	H'04F001	H'04F002	←Programming unit: 128 bytes→	H'04F07F
Erase unit: 64 kbytes	H'04FF80	H'04FF81	H'04FF82	-----	H'04FFFF
EB13*1	H'050000	H'050001	H'050002	←Programming unit: 128 bytes→	H'05007F
Erase unit: 64 kbytes	H'05FF80	H'05FF81	H'05FF82	-----	H'05FFFF
EB14*1≠2	H'060000	H'060001	H'060002	←Programming unit: 128 bytes→	H'06007F
Erase unit: 64 kbytes	H'06FF80	H'06FF81	H'06FF82	-----	H'06FFFF
EB15*1≠2	H'070000	H'070001	H'070002	←Programming unit: 128 bytes→	H'07007F
Erase unit: 64 kbytes	H'07FF80	H'07FF81	H'07FF82	-----	H'07FFFF

Notes: 1. EB12 to EB15 are not available in the H8S/2168.
2. EB14 and EB15 are not available in the H8S/2167.

Figure 20.4 Block Division of User MAT

20.1.5 Programming/Erasing Interface

Programming/erasing is executed by downloading the on-chip program to the on-chip RAM and specifying the program address/data and erase block by using the interface register/parameter.

The procedure program is made by the user in user program mode and user boot mode. An overview of the procedure is given as follows. For details, see section 20.4.2, User Program Mode.

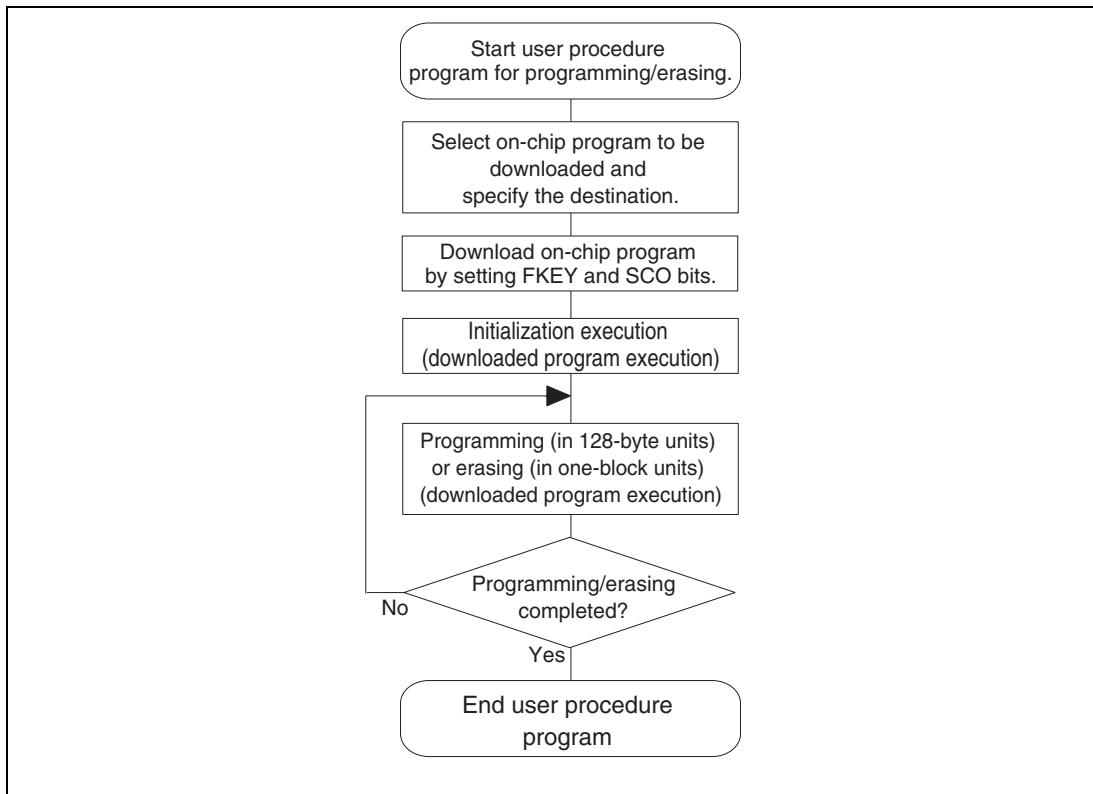

Figure 20.5 Overview of User Procedure Program

1. Selection of on-chip program to be downloaded

For programming/erasing execution, the FLSHE bit in STCR must be set to 1 to transition to user program mode.

This LSI has programming/erasing programs which can be downloaded to the on-chip RAM. The on-chip program to be downloaded is selected by setting the corresponding bits in the programming/erasing interface register. The address of the programming destination is specified by the flash transfer destination address register (FTDAR).

2. Download of on-chip program

The on-chip program is automatically downloaded by setting the flash key code register (FKEY) and the SCO bit in the flash code control status register (FCCS), which are programming/erasing interface registers.

The flash memory is replaced to the embedded program storage area when downloading. Since the flash memory cannot be read when programming/erasing, the procedure program, which is working from download to completion of programming/erasing, must be executed in the space other than the flash memory to be programmed/erased (for example, on-chip RAM).

Since the result of download is returned to the programming/erasing interface parameter, whether the normal download is executed or not can be confirmed.

3. Initialization of programming/erasing

The operating frequency is set before execution of programming/erasing. This setting is performed by using the programming/erasing interface parameter.

4. Programming/erasing execution

For programming/erasing execution, the FLSHE bit in STCR and the FWE pin must be set to 1 to transition to user program mode.

The program data/programming destination address is specified in 128-byte units when programming.

The block to be erased is specified in erase-block units when erasing.

These specifications are set by using the programming/erasing interface parameter and the on-chip program is initiated. The on-chip program is executed by using the JSR or BSR instruction and performing the subroutine call of the specified address in the on-chip RAM. The execution result is returned to the programming/erasing interface parameter.

The area to be programmed must be erased in advance when programming flash memory. All interrupts are prohibited during programming and erasing. Interrupts must be masked within the user system.

5. When programming/erasing is executed consecutively

When the processing is not ended by the 128-byte programming or one-block erasure, the program address/data and erase-block number must be updated and consecutive programming/erasing is required.

Since the downloaded on-chip program is left in the on-chip RAM after the processing, download and initialization are not required when the same processing is executed consecutively.

20.2 Input/Output Pins

Table 20.2 shows the flash memory pin configuration.

Table 20.2 Pin Configuration

Pin Name	Input/Output	Function
RES	Input	Reset
FWE	Input	Flash memory programming/erasing enable pin
MD2	Input	Sets operating mode of this LSI
MD1	Input	Sets operating mode of this LSI
MD0	Input	Sets operating mode of this LSI
TxD1	Output	Serial transmit data output (used in boot mode)
RxD1	Input	Serial receive data input (used in boot mode)

20.3 Register Descriptions

The registers/parameters which control flash memory are shown in the following. To read from or write to these registers/parameters, the FLSHE bit in the serial timer control register (STCR) must be set to 1. For details on STCR, see section 3.2.3, Serial Timer Control Register (STCR).

- Flash code control status register (FCCS)
- Flash program code select register (FPCS)
- Flash erase code select register (FECS)
- Flash key code register (FKEY)
- Flash MAT select register (FMATS)
- Flash transfer destination address register (FTDAR)
- Download pass/fail result (DPFR)
- Flash pass/fail result (FPFR)
- Flash multipurpose address area (FMPAR)
- Flash multipurpose data destination area (FMPDR)
- Flash erase Block select (FEBS)
- Flash programming/erasing frequency control (FPEFEQ)

There are several operating modes for accessing flash memory, for example, read mode/program mode.

There are two memory MATs: user MAT and user boot MAT. The dedicated registers/parameters are allocated for each operating mode and MAT selection. The correspondence of operating modes and registers/parameters for use is shown in table 20.3.

Table 20.3 Register/Parameter and Target Mode

		Download	Initiali- zation	Program- ming	Eraseure	Read
Programming/ Erasing Interface Register	FCCS	○	—	—	—	—
	FPCS	○	—	—	—	—
	FECS	○	—	—	—	—
	FKEY	○	—	○	○	—
	FMATS	—	—	○ * ¹	○ * ¹	○ * ²
	FTDAR	○	—	—	—	—
Programming/ Erasing Interface Parameter	DPFR	○	—	—	—	—
	FPFR	—	○	○	○	—
	FPEFEQ	—	○	—	—	—
	FMPAR	—	—	○	—	—
	FMPDR	—	—	○	—	—
	FEBS	—	—	—	○	—

- Notes: 1. The setting is required when programming or erasing user MAT in user boot mode.
2. The setting may be required according to the combination of initiation mode and read target MAT.

20.3.1 Programming/Erasing Interface Register

The programming/erasing interface registers are as described below. They are all 8-bit registers that can be accessed in byte. These registers are initialized at a reset or in hardware standby mode.

- Flash Code Control Status Register (FCCS)

FCCS is configured by bits which request the monitor of the FWE pin state and error occurrence during programming or erasing flash memory and the download of on-chip program.

Bit	Bit Name	Initial Value	R/W	Description
7	FWE	1/0	R	Flash Program Enable Monitors the signal level input to the FWE pin and enables or disables programming/erasing flash memory. 0: Programming/erasing disabled 1: Programming/erasing enabled
6, 5	—	All 0	R/W	Reserved The initial value should not be changed.
4	FLER	0	R	Flash Memory Error Indicates an error occurs during programming and erasing flash memory. When FLER is set to 1, flash memory enters the error protection state. When FLER is set to 1, high voltage is applied to the internal flash memory. To reduce the damage to flash memory, the reset must be released after the reset period of 100 μ s which is longer than normal. 0: Flash memory operates normally. Programming/erasing protection for flash memory (error protection) is invalid. [Clearing condition] <ul style="list-style-type: none"> At a reset or in hardware standby mode 1: An error occurs during programming/erasing flash memory. Programming/erasing protection for flash memory (error protection) is valid. [Setting conditions] <ul style="list-style-type: none"> When an interrupt, such as NMI, occurs during programming/erasing flash memory. When the flash memory is read during programming/erasing flash memory (including a vector read or an instruction fetch). When the SLEEP instruction is executed during programming/erasing flash memory (including software-standby mode) When a bus master other than the CPU, such as the DTC, gets bus mastership during programming/erasing flash memory.

Bit	Bit Name	Initial Value	R/W	Description
3	WEINTE	0	R/W	<p>Program/Erase Enable</p> <p>Modifies the space for the interrupt vector table, when interrupt vector data is not read successfully during programming/erasing flash memory or switching between a user MAT and a user boot MAT. When this bit is set to 1, interrupt vector data is read from address spaces H'FFE080 to H'FFE0FF (on-chip RAM space), instead of from address spaces H'000000 to H'00007F (up to vector number 31). Therefore, make sure to set the vector table in the on-chip RAM space before setting this bit to 1.</p> <p>The interrupt exception handling on and after vector number 32 should not be used because the correct vector is not read, resulting in the CPU runaway.</p> <p>0: The space for the interrupt vector table is not modified.</p> <p>When interrupt vector data is not read successfully, the operation for the interrupt exception handling cannot be guaranteed. An occurrence of any interrupts should be masked.</p> <p>1: The space for the interrupt vector table is modified. Even when interrupt vector data is not read successfully, the interrupt exception handling up to vector number 31 is enabled.</p>
2, 1	—	All 0	R/W	<p>Reserved</p> <p>The initial value should not be changed.</p>
0	SCO	0	(R)/W*	<p>Source Program Copy Operation</p> <p>Requests the on-chip programming/erasing program to be downloaded to the on-chip RAM.</p> <p>When this bit is set to 1, the on-chip program which is selected by FPCS/FECS is automatically downloaded in the on-chip RAM specified by FTDAR.</p> <p>In order to set this bit to 1, H'A5 must be written to FKEY and this operation must be executed in the on-chip RAM.</p> <p>Four NOP instructions must be executed immediately after setting this bit to 1.</p> <p>Since this bit is cleared to 0 when download is completed, this bit cannot be read as 1.</p> <p>All interrupts must be disabled. This should be made in the user system.</p> <p>0: Download of the on-chip programming/erasing program to the on-chip RAM is not executed.</p>

Bit	Bit Name	Initial Value	R/W	Description
0	SCO	0	(R)/W*	<p>[Clearing condition] When download is completed</p> <p>1: Request that the on-chip programming/erasing program is downloaded to the on-chip RAM is occurred.</p> <p>[Setting conditions] When all of the following conditions are satisfied and 1 is set to this bit</p> <ul style="list-style-type: none"> • H'A5 is written to FKEY • During execution in the on-chip RAM

Note: * This bit is a write only bit. This bit is always read as 0.

- Flash Program Code Select Register (FPCS)

FPCS selects the on-chip programming program to be downloaded.

Bit	Bit Name	Initial Value	R/W	Description
7 to 1	—	All 0	R/W	<p>Reserved</p> <p>The initial value should not be changed.</p>
0	PPVS	0	R/W	<p>Program Pulse Verify</p> <p>Selects the programming program.</p> <p>0: On-chip programming program is not selected.</p> <p>[Clearing condition] When transfer is completed</p> <p>1: On-chip programming program is selected.</p>

- Flash Erase Code Select Register (FECS)

FECS selects download of the on-chip erasing program.

Bit	Bit Name	Initial Value	R/W	Description
7 to 1	—	All 0	R/W	<p>Reserved</p> <p>The initial value should not be changed.</p>
0	EPVB	0	R/W	<p>Erase Pulse Verify Block</p> <p>Selects the erasing program.</p> <p>0: On-chip erasing program is not selected.</p> <p>[Clearing condition] When transfer is completed</p> <p>1: On-chip erasing program is selected.</p>

- Flash Key Code Register (FKEY)

FKEY is a register for software protection that enables download of on-chip program and programming/erasing of flash memory. Before setting the SCO bit to 1 in order to download on-chip program or executing the downloaded programming/erasing program, these processing cannot be executed if the key code is not written.

Bit	Bit Name	Initial Value	R/W	Description
7	K7	0	R/W	Key Code
6	K6	0	R/W	Only when H'A5 is written, writing to the SCO bit is valid. When the value other than H'A5 is written to FKEY, 1 cannot be set to the SCO bit. Therefore downloading to the on-chip RAM cannot be executed.
5	K5	0	R/W	
4	K4	0	R/W	Only when H'5A is written, programming/erasing can be executed. Even if the on-chip programming/erasing program is executed, the flash memory cannot be programmed or erased when the value other than H'5A is written to FKEY.
3	K3	0	R/W	
2	K2	0	R/W	H'A5: Writing to the SCO bit is enabled. (The SCO bit cannot be set by the value other than H'A5.) H'5A: Programming/erasing is enabled. (The value other than H'A5 is in software protection state.)
1	K1	0	R/W	
0	K0	0	R/W	H'00: Initial value

- Flash MAT Select Register (FMATS)

FMATS specifies whether user MAT or user boot MAT is selected.

Bit	Bit Name	Initial Value	R/W	Description
7	MS7	0/1*	R/W	MAT Select
6	MS6	0	R/W	These bits are in user-MAT selection state when the value other than H'AA is written and in user-boot-MAT selection state when H'AA is written.
5	MS5	0/1*	R/W	
4	MS4	0	R/W	The MAT is switched by writing the value in FMATS.
3	MS3	0/1*	R/W	
2	MS2	0	R/W	When the MAT is switched, follow section 20.6, Switching between User MAT and User Boot MAT. (The user boot MAT cannot be programmed in user program mode if user boot MAT is selected by FMATS. The user boot MAT must be programmed in boot mode or in programmer mode.)
1	MS1	0/1*	R/W	
0	MS0	0	R/W	<p>H'AA: The user boot MAT is selected (in user-MAT selection state when the value of these bits are other than H'AA)</p> <p>Initial value when these bits are initiated in user boot mode.</p> <p>H'00: Initial value when these bits are initiated in a mode except for user boot mode (in user-MAT selection state)</p> <p>[Programmable condition]</p> <p>These bits are in the execution state in the on-chip RAM.</p>

Note: * Set to 1 when in user boot mode, otherwise set to 0.

- Flash Transfer Destination Address Register (FTDAR)

FTDAR is a register that specifies the address to download an on-chip program. This register must be specified before setting the SCO bit in FCCS to 1.

Bit	Bit Name	Initial Value	R/W	Description
7	TDER	0	R/W	<p>Transfer Destination Address Setting Error</p> <p>This bit is set to 1 when the address specified by bits TDA6 to TDA0, which is the start address to download an on-chip program, is over the range. Whether or not the range specified by bits TDA6 to TDA0 is within the range of H'00 to H'03 is determined when an on-chip program is downloaded by setting the SCO bit in FCCS to 1. Make sure that this bit is cleared to 0 before setting the SCO bit to 1 and the value specified by TDA6 to TDA0 is within the range of H'00 to H'03.</p> <p>0: The value specified by bits TDA6 to TDA0 is within the range.</p> <p>1: The value specified by is TDA6 to TDA0 is over the range (H'04 to H'FF) and the download is stopped.</p>
6	TDA6	0	R/W	Transfer Destination Address
5	TDA5	0	R/W	<p>Specifies the start address to download an on-chip program. H'00 to H'03 can be specified as the start address in the on-chip RAM space.</p> <p>H'00: H'FFE080 is specified as a start address to download an on-chip program.</p> <p>H'01: H'FF0800 is specified as a start address to download an on-chip program.</p> <p>H'02: H'FF1800 is specified as a start address to download an on-chip program.</p> <p>H'03: H'FF8800 is specified as a start address to download an on-chip program.</p> <p>H'04 to H'FF: Setting prohibited. Specifying this value sets the TDER bit to 1 and stops the download.</p>
4	TDA4	0	R/W	
3	TDA3	0	R/W	
2	TDA2	0	R/W	
1	TDA1	0	R/W	
0	TDA0	0	R/W	

20.3.2 Programming/Erasing Interface Parameter

The programming/erasing interface parameter specifies the operating frequency, storage place for program data, programming destination address, and erase block and exchanges the processing result for the downloaded on-chip program. This parameter uses the general registers of the CPU (ER0 and ER1) or the on-chip RAM area. The initial value is undefined at a reset or in hardware standby mode.

When download, initialization, or on-chip program is executed, registers of the CPU except for R0L are stored. The return value of the processing result is written in R0L. Since the stack area is used for storing the registers except for R0L, the stack area must be saved at the processing start. (A maximum size of a stack area to be used is 128 bytes.)

The programming/erasing interface parameter is used in the following four items.

1. Download control
2. Initialization before programming or erasing
3. Programming
4. Erasing

These items use different parameters. The correspondence table is shown in table 20.4. The meaning of the bits in FPFRR varies in each processing program: initialization, programming, or erasure. For details, see descriptions of FPFRR for each process.

Table 20.4 Parameters and Target Modes

Name of Parameter	Abbreviation	Down Load	Initializa-tion	Program-ming	Erasure	R/W	Initial Value	Alloca-tion
Download pass/fail result	DPFR	○	—	—	—	R/W	Undefined	On-chip RAM*
Flash pass/fail result	FPFR	—	○	○	○	R/W	Undefined	ROL of CPU
Flash programming/erasing frequency control	FPEFEQ	—	○	—	—	R/W	Undefined	ER0 of CPU
Flash multipurpose address area	FMPAR	—	—	○	—	R/W	Undefined	ER1 of CPU
Flash multipurpose data destination area	FMPDR	—	—	○	—	R/W	Undefined	ER0 of CPU
Flash erase block select	FEBS	—	—	—	○	R/W	Undefined	ROL of CPU

Note: * A single byte of the start address to download an on-chip program, which is specified by FTDAR

(1) Download Control

The on-chip program is automatically downloaded by setting the SCO bit to 1. The on-chip RAM area to be downloaded is the 2-kbyte area starting from the address specified by FTDAR.

Download control is set by the program/erase interface registers, and the DPFR parameter indicates the return value.

(a) Download pass/fail result parameter (DPFR: single byte of start address specified by FTDAR)

This parameter indicates the return value of the download result. The value of this parameter can be used to determine if downloading is executed or not. Since the confirmation whether the SCO bit is set to 1 is difficult, the certain determination must be performed by writing the single byte of the start address specified by FTDAR to the value other than the return value of download (for example, H'FF) before the download start (before setting the SCO bit to 1).

Bit	Bit Name	Initial Value	R/W	Description
7 to 3	—	—	—	Unused Return 0
2	SS	—	R/W	Source Select Error Detect Only one type for the on-chip program which can be downloaded can be specified. When more than two types of the program are selected, the program is not selected, or the program is selected without mapping, error is occurred. 0: Download program can be selected normally 1: Download error is occurred (multi-selection or program which is not mapped is selected)
1	FK	—	R/W	Flash Key Register Error Detect Returns the check result whether the value of FKEY is set to H'A5. 0: KEY setting is normal (FKEY = H'A5) 1: Setting value of FKEY becomes error (FKEY = value other than H'A5)
0	SF	—	R/W	Success/Fail Returns the result whether download is ended normally or not. The determination result whether program that is downloaded to the on-chip RAM is read back and then transferred to the on-chip RAM is returned. 0: Downloading on-chip program is ended normally (no error) 1: Downloading on-chip program is ended abnormally (error occurs)

(2) Programming/Erasing Initialization

The on-chip programming/erasing program to be downloaded includes the initialization program.

The specified period pulse must be applied when programming or erasing. The specified pulse width is made by the method in which wait loop is configured by the CPU instruction. The operating frequency of the CPU must be set.

The initial program is set as a parameter of the programming/erasing program which has downloaded these settings.

(a) Flash programming/erasing frequency parameter (FPEFEQ: general register ER0 of CPU)

This parameter sets the operating frequency of the CPU. The settable range of the operating frequency in this LSI is 5 to 33 MHz.

Bit	Bit Name	Initial Value	R/W	Description
31 to 16	—	—	—	Unused This bit should be cleared to 0.
15 to 0	F15 to F0	—	R/W	Frequency Set Set the operating frequency of the CPU. With the PLL multiplication function, set the frequency multiplied. The setting value must be calculated as the following methods. <ol style="list-style-type: none">1. The operating frequency which is shown in MHz units must be rounded in a number to three decimal places and be shown in a number of two decimal places.2. The value multiplied by 100 is converted to the binary digit and is written to the FPEFEQ parameter (general register ER0). For example, when the operating frequency of the CPU is 33.000 MHz, the value is as follows. <ol style="list-style-type: none">1. The number to three decimal places of 33.000 is rounded and the value is thus 33.00.2. The formula that $33.00 \times 100 = 3300$ is converted to the binary digit and B'0000,1100,1110,0100 (H'0CE4) is set to ER0.

(b) Flash pass/fail parameter (FPFR: general register R0L of CPU)

This parameter indicates the return value of the initialization result.

Bit	Bit Name	Initial Value	R/W	Description
7 to 2	—	—	—	Unused Return 0
1	FQ	—	R/W	Frequency Error Detect Returns the check result whether the specified operating frequency of the CPU is in the range of the supported operating frequency. 0: Setting of operating frequency is normal 1: Setting of operating frequency is abnormal
0	SF	—	R/W	Success/Fail Indicates whether initialization is completed normally. 0: Initialization is ended normally (no error) 1: Initialization is ended abnormally (error occurs)

(3) Programming Execution

When flash memory is programmed, the programming destination address on the user MAT must be passed to the programming program in which the program data is downloaded.

1. The start address of the programming destination on the user MAT must be stored in a general register ER1. This parameter is called as flash multipurpose address area parameter (FMPAR). Since the program data is always in units of 128 bytes, the lower eight bits (A7 to A0) must be H'00 or H'80 as the boundary of the programming start address on the user MAT.
2. The program data for the user MAT must be prepared in the consecutive area. The program data must be in the consecutive space which can be accessed by using the MOV.B instruction of the CPU and in other than the flash memory space.
When data to be programmed does not satisfy 128 bytes, the 128-byte program data must be prepared by filling with the dummy code H'FF.
The start address of the area in which the prepared program data is stored must be stored in a general register ER0. This parameter is called as flash multipurpose data destination area parameter (FMPDR).

For details on the program processing procedure, see section 20.4.2, User Program Mode.

(a) Flash multipurpose address area parameter (FMPAR: general register ER1 of CPU)

This parameter stores the start address of the programming destination on the user MAT.

When the address in the area other than flash memory space is set, an error occurs.

The start address of the programming destination must be at the 128-byte boundary. If this boundary condition is not satisfied, an error occurs. The error occurrence is indicated by the WA bit (bit 1) in FPFR.

Bit	Bit Name	Initial Value	R/W	Description
31 to 0	MOA31 to MOA0	—	R/W	Store the start address of the programming destination on the user MAT. The consecutive 128-byte programming is executed starting from the specified start address of the user MAT. Therefore, the specified programming start address becomes a 128-byte boundary and MOA6 to MOA0 are always 0.

(b) Flash multipurpose data destination parameter (FMPDR: general register ER0 of CPU):

This parameter stores the start address in the area which stores the data to be programmed in the user MAT. When the storage destination of the program data is in flash memory, an error occurs. The error occurrence is indicated by the WD bit in FPFR.

Bit	Bit Name	Initial Value	R/W	Description
31 to 0	MOD31 to MOD0	—	R/W	Store the start address of the area which stores the program data for the user MAT. The consecutive 128-byte data is programmed to the user MAT starting from the specified start address.

(c) Flash pass/fail parameter (FPFR: general register R0L of CPU)

This parameter indicates the return value of the program processing result.

Bit	Bit Name	Initial Value	R/W	Description
7	—	—	—	Unused Return 0.

Bit	Bit Name	Initial Value	R/W	Description
6	MD	—	R/W	<p>Programming Mode Related Setting Error Detect</p> <p>Returns the check result that a high level signal is input to the FWE pin and the error protection state is not entered. When the low level signal is input to the FWE pin or the error protection state is entered, 1 is written to this bit. The state can be confirmed with the FWE and FLER bits in FCCS. For conditions to enter the error protection state, see section 20.5.3, Error Protection.</p> <p>0: FWE and FLER settings are normal (FWE = 1, FLER = 0)</p> <p>1: Programming cannot be performed (FWE = 0 or FLER = 1)</p>
5	EE	—	R/W	<p>Programming Execution Error Detect</p> <p>1 is returned to this bit when the specified data could not be written because the user MAT was not erased. If this bit is set to 1, there is a high possibility that the user MAT is partially rewritten. In this case, after removing the error factor, erase the user MAT.</p> <p>If FMATS is set to H'AA and the user boot MAT is selected, an error occurs when programming is performed. In this case, both the user MAT and user boot MAT are not rewritten. Programming of the user boot MAT should be performed in boot mode or programmer mode.</p> <p>0: Programming has ended normally</p> <p>1: Programming has ended abnormally (programming result is not guaranteed)</p>
4	FK	—	R/W	<p>Flash Key Register Error Detect</p> <p>Returns the check result of the value of FKEY before the start of the programming processing.</p> <p>0: FKEY setting is normal (FKEY = H'5A)</p> <p>1: FKEY setting is error (FKEY = value other than H'5A)</p>
3	—	—	—	<p>Unused</p> <p>Returns 0.</p>
2	WD	—	R/W	<p>Write Data Address Detect</p> <p>When the address in the flash memory area is specified as the start address of the storage destination of the program data, an error occurs.</p> <p>0: Setting of write data address is normal</p> <p>1: Setting of write data address is abnormal</p>

Bit	Bit Name	Initial Value	R/W	Description
1	WA	—	R/W	<p>Write Address Error Detect</p> <p>When the following items are specified as the start address of the programming destination, an error occurs.</p> <ul style="list-style-type: none"> • When the programming destination address in the area other than flash memory is specified • When the specified address is not in a 128-byte boundary. (The lower eight bits of the address are other than H'00 and H'80.) <p>0: Setting of programming destination address is normal 1: Setting of programming destination address is abnormal</p>
0	SF	—	R/W	<p>Success/Fail</p> <p>Indicates whether the program processing is ended normally or not.</p> <p>0: Programming is ended normally (no error) 1: Programming is ended abnormally (error occurs)</p>

(4) Erasure Execution

When flash memory is erased, the erase-block number on the user MAT must be passed to the erasing program which is downloaded. This is set to the FEBS parameter (general register ER0).

One block is specified from the block number 0 to 15.

For details on the erasing processing procedure, see section 20.4.2, User Program Mode.

(a) Flash erase block select parameter (FEBS: general register ER0 of CPU)

This parameter specifies the erase-block number. The several block numbers cannot be specified.

Bit	Bit Name	Initial Value	R/W	Description
31 to 8	—	—	—	Unused These bits should be cleared to H'0.
7	EB7	—	R/W	Erase Block
6	EB6	—	R/W	Set the erase-block number in the range from 0 to 15. 0 corresponds to the EB0 block and 15 corresponds to the EB15 block. The number other than 0 to 11, 0 to 13, and 0 to 15 should not be set in the H8S/2168, H8S/2167, and H8S/2166, respectively.
5	EB5	—	R/W	
4	EB4	—	R/W	
3	EB3	—	R/W	
2	EB2	—	R/W	
1	EB1	—	R/W	
0	EB0	—	R/W	

(b) Flash pass/fail parameter (FPFR: general register R0L of CPU)

This parameter returns value of the erasing processing result.

Bit	Bit Name	Initial Value	R/W	Description
7	—	—	—	Unused Return 0.
6	MD	—	R/W	Programming Mode Related Setting Error Detect Returns the check result that a high level signal is input to the FWE pin and the error protection state is not entered. When the low level signal is input to the FWE pin or the error protection state is entered, 1 is written to this bit. The state can be confirmed with the FWE and FLER bits in FCCS. For conditions to enter the error protection state, see section 20.5.3, Error Protection. 0: FWE and FLER settings are normal (FWE = 1, FLER = 0) 1: Programming cannot be performed (FWE = 0 or FLER = 1)
5	EE	—	R/W	Erase Execution Error Detect 1 is returned to this bit when the user MAT could not be erased or when flash-memory related register settings are partially changed. If this bit is set to 1, there is a high possibility that the user MAT is partially erased. In this case, after removing the error factor, erase the user MAT. If FMATS is set to H'AA and the user boot MAT is selected, an error occurs when erasure is performed. In this case, both the user MAT and user boot MAT are not erased. Erasing of the user boot MAT should be performed in boot mode or programmer mode. 0: Erasure has ended normally 1: Erasure has ended abnormally (erasure result is not guaranteed)
4	FK	—	R/W	Flash Key Register Error Detect Returns the check result of FKEY value before start of the erasing processing. 0: FKEY setting is normal (FKEY = H'5A) 1: FKEY setting is error (FKEY = value other than H'5A)
3	EB	—	R/W	Erase Block Select Error Detect Returns the check result whether the specified erase-block number is in the block range of the user MAT. 0: Setting of erase-block number is normal 1: Setting of erase-block number is abnormal

Bit	Bit Name	Initial Value	R/W	Description
2, 1	—	—	—	Unused Return 0.
0	SF	—	R/W	Success/Fail Indicates whether the erasing processing is ended normally or not. 0: Erasure is ended normally (no error) 1: Erasure is ended abnormally (error occurs)

20.4 On-Board Programming Mode

When the pin is set in on-board programming mode and the reset start is executed, the on-board programming state that can program/erase the on-chip flash memory is entered. On-board programming mode has three operating modes: boot mode, user program mode, and user boot mode.

For details of the pin setting for entering each mode, see table 20.5. For details of the state transition of each mode for flash memory, see figure 20.2.

Table 20.5 Setting On-Board Programming Mode

Mode Setting	FWE	$\overline{\text{MD2}}$	MD1	MD0	NMI
Boot mode	1	0	0	0	1
User program mode	1*	1	1	0	0/1
User boot mode	1	0	0	0	0

Note: * Before downloading the programming/erasing programs, the FLSHE bit must be set to 1 to transition to user program mode.

20.4.1 Boot Mode

Boot mode executes programming/erasing user MAT and user boot MAT by means of the control command and program data transmitted from the host using the on-chip SCI. The tool for transmitting the control command and program data must be prepared in the host. The SCI communication mode is set to asynchronous mode. When reset start is executed after this LSI's pin is set in boot mode, the boot program in the microcomputer is initiated. After the SCI bit rate is automatically adjusted, the communication with the host is executed by means of the control command method.

The system configuration diagram in boot mode is shown in figure 20.6. For details on the pin setting in boot mode, see table 20.5. The NMI and other interrupts are ignored in boot mode. However, the NMI and other interrupts should be disabled in the user system.

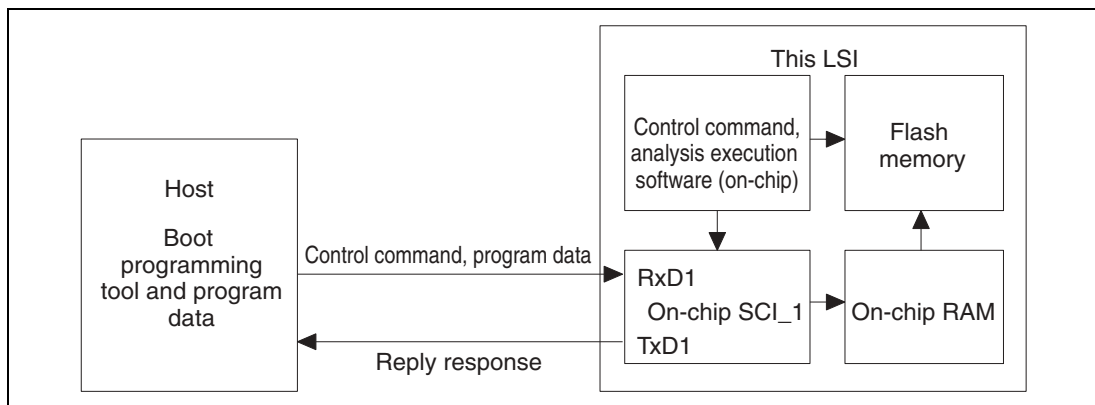

Figure 20.6 System Configuration in Boot Mode

(1) SCI Interface Setting by Host

When boot mode is initiated, this LSI measures the low period of asynchronous SCI-communication data (H'00), which is transmitted consecutively by the host. The SCI transmit/receive format is set to 8-bit data, 1 stop bit, and no parity. This LSI calculates the bit rate of transmission by the host by means of the measured low period and transmits the bit adjustment end sign (1 byte of H'00) to the host. The host must confirm that this bit adjustment end sign (H'00) has been received normally and transmits 1 byte of H'55 to this LSI. When reception is not executed normally, boot mode is initiated again (reset) and the operation described above must be executed. The bit rate between the host and this LSI is not matched by the bit rate of transmission by the host and system clock frequency of this LSI. To operate the SCI normally, the transfer bit rate of the host must be set to 4,800 bps, 9,600 bps, or 19,200 bps.

The system clock frequency, which can automatically adjust the transfer bit rate of the host and the bit rate of this LSI, is shown in table 20.6. Boot mode must be initiated in the range of this system clock.

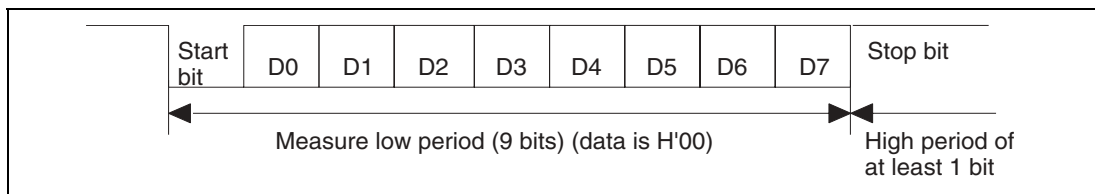

Figure 20.7 Automatic-Bit-Rate Adjustment Operation of SCI

Table 20.6 System Clock Frequency for Automatic-Bit-Rate Adjustment by This LSI

Bit Rate of Host	System Clock Frequency
4,800 bps	5 to 33 MHz
9,600 bps	5 to 33 MHz
19,200 bps	8 to 33 MHz

(2) State Transition Diagram

The overview of the state transition diagram after boot mode is initiated is shown in figure 20.8.

1. Bit rate adjustment

After boot mode is initiated, the bit rate of the SCI interface is adjusted with that of the host.

2. Waiting for inquiry set command

For inquiries about user-MAT size and configuration, MAT start address, and support state, the required information is transmitted to the host.

3. Automatic erasure of all user MAT and user boot MAT

After inquiries have finished, all user MAT and user boot MAT are automatically erased.

4. Waiting for programming/erasing command

- When the program preparation notice is received, the state for waiting program data is entered. The programming start address and program data must be transmitted following the programming command. When programming is finished, the programming start address must be set to H'FFFFFFFF and transmitted. Then the state for waiting program data is returned to the state of programming/erasing command wait.
- When the erasure preparation notice is received, the state for waiting erase-block data is entered. The erase-block number must be transmitted following the erasing command. When the erasure is finished, the erase-block number must be set to H'FF and transmitted. Then the state for waiting erase-block data is returned to the state for waiting programming/erasing command. The erasure must be used when the specified block is programmed without a reset start after programming is executed in boot mode. When programming can be executed by only one operation, all blocks are erased before the state for waiting programming/erasing/other command is entered. The erasing operation is not required.
- There are many commands other than programming/erasing. Examples are sum check, blank check (erasure check), and memory read of the user MAT/user boot MAT and acquisition of current status information.

Note that memory read of the user MAT/user boot MAT can only read the programmed data after all user MAT/user boot MAT has automatically been erased.

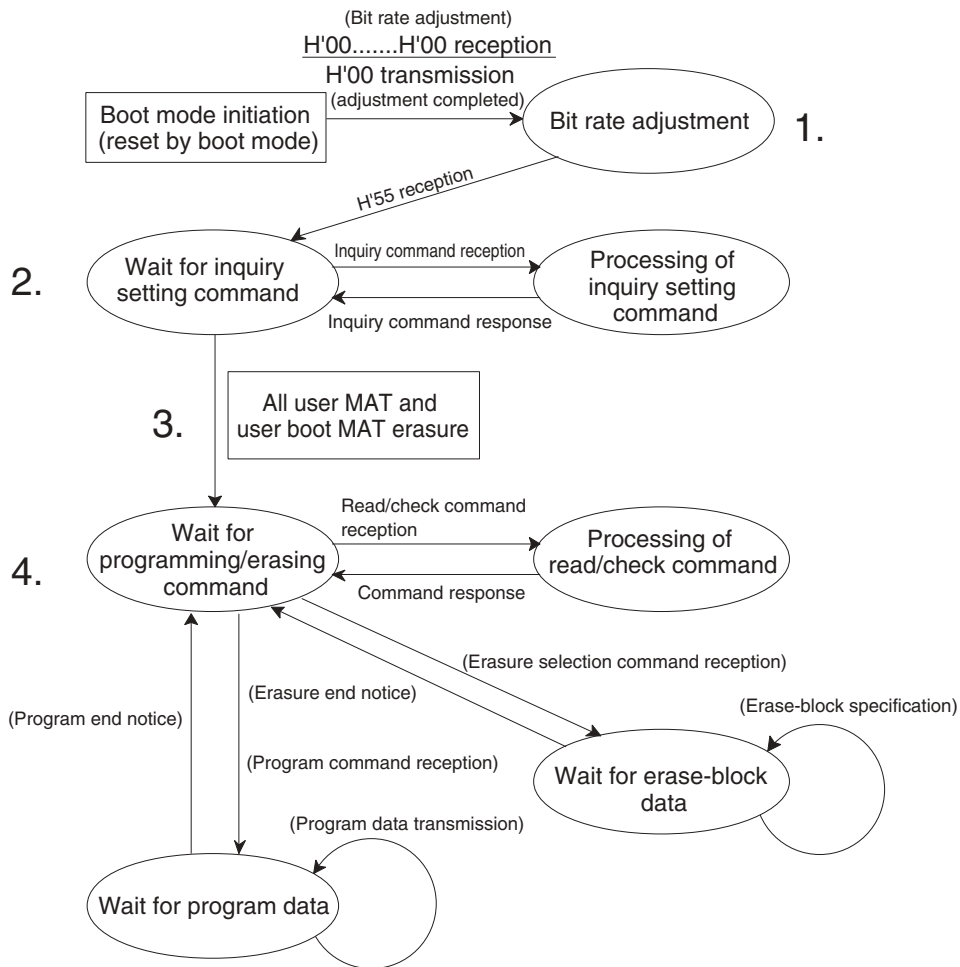

Figure 20.8 Overview of Boot Mode State Transition Diagram

20.4.2 User Program Mode

The user MAT can be programmed/erased in user program mode. (The user boot MAT cannot be programmed/erased.)

Programming/erasing is executed by downloading the program in the microcomputer.

The overview flow is shown in figure 20.9.

High voltage is applied to internal flash memory during the programming/erasing processing. Therefore, transition to reset or hardware standby must not be executed. Doing so may damage or destroy flash memory. If reset is executed accidentally, reset must be released after the reset input period of 100 μ s which is longer than normal.

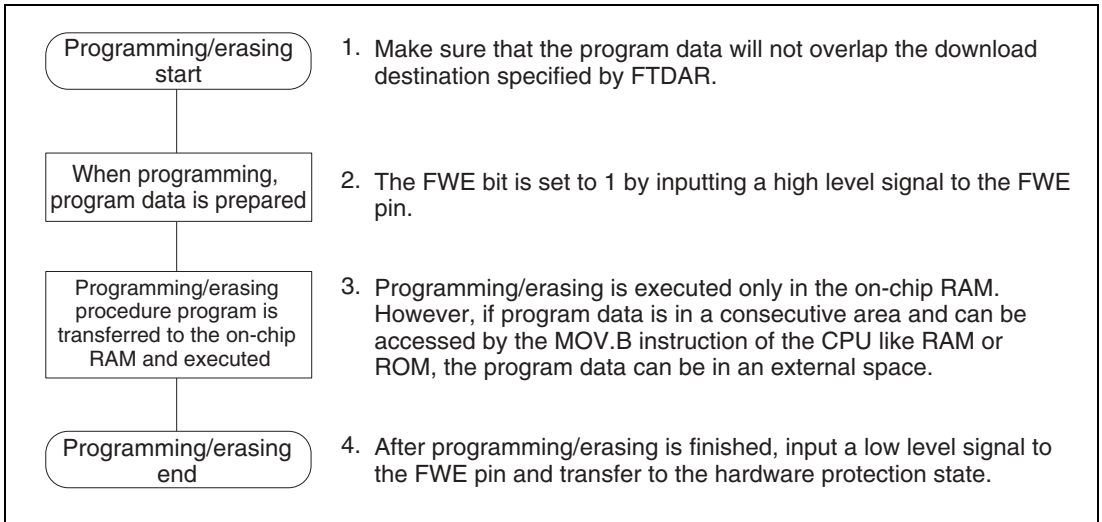

Figure 20.9 Programming/Erasing Overview Flow

(1) On-chip RAM Address Map when Programming/Erasing is Executed

Parts of the procedure program that are made by the user, like download request, programming/erasing procedure, and determination of the result, must be executed in the on-chip RAM. The on-chip program that is to be downloaded is all in the on-chip RAM. Note that area in the on-chip RAM must be controlled so that these parts do not overlap.

Figure 20.10 shows the program area to be downloaded.

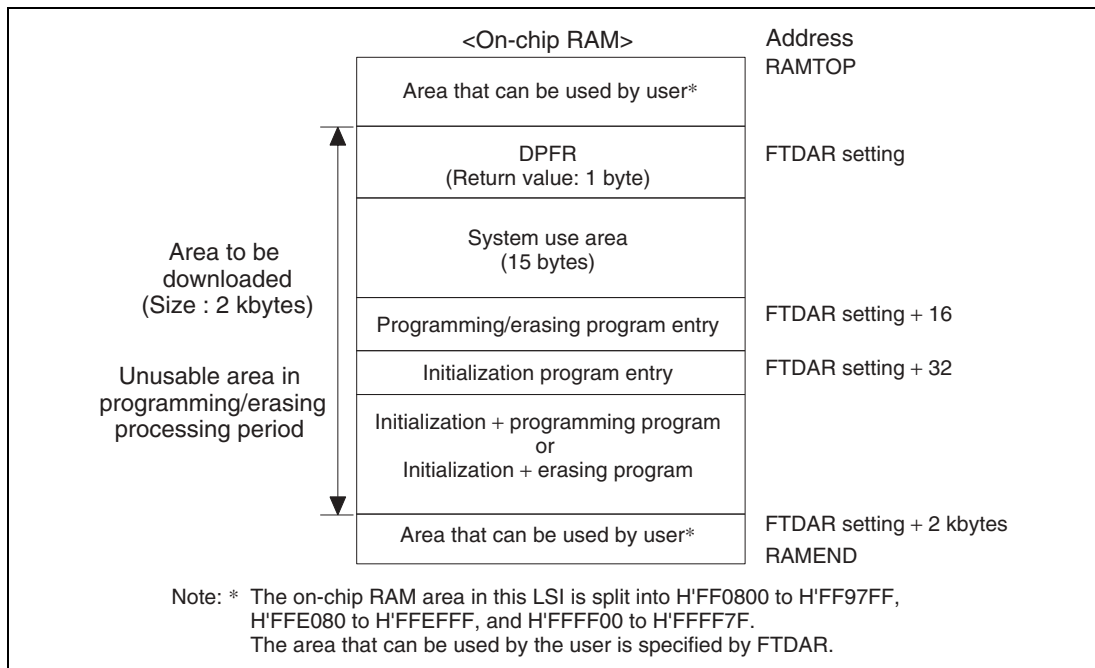

Figure 20.10 RAM Map When Programming/Erasing is Executed

(2) Programming Procedure in User Program Mode

The procedures for download, initialization, and programming are shown in figure 20.11.

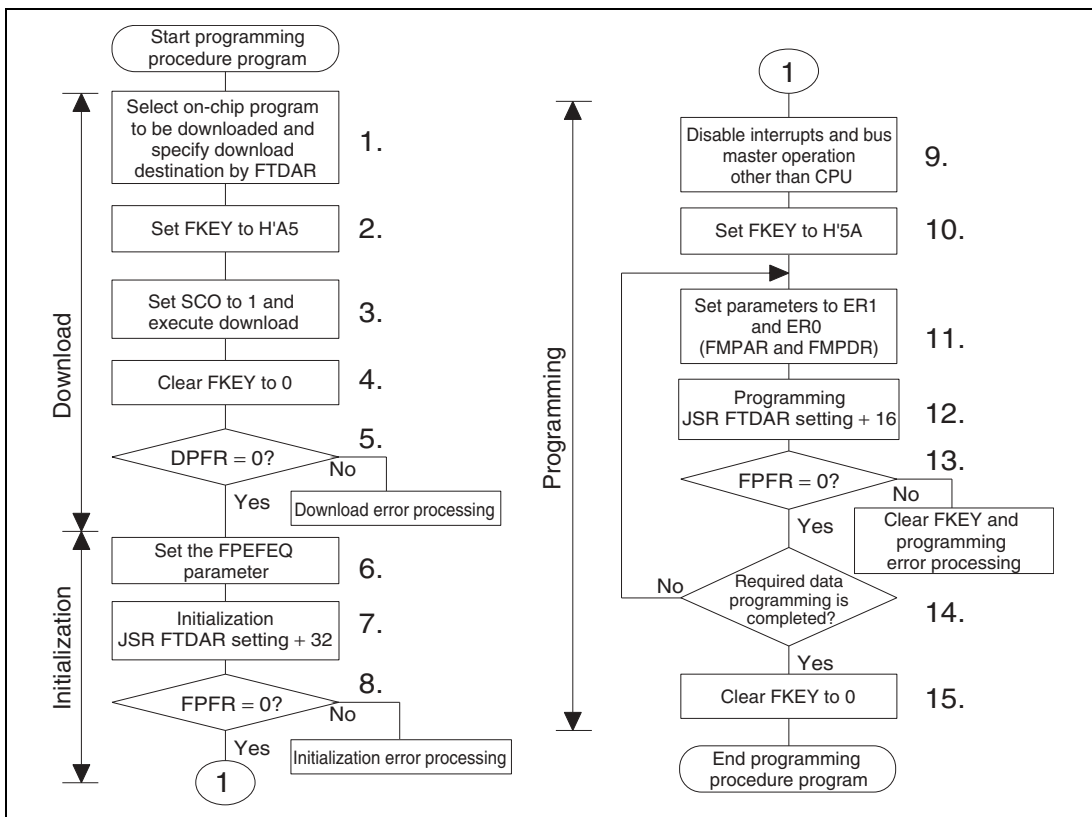

Figure 20.11 Programming Procedure

The procedure program must be executed in an area other than the flash memory to be programmed. Especially the part where the SCO bit in FCCS is set to 1 for downloading must be executed in the on-chip RAM.

The area that can be executed in the steps of the user procedure program (on-chip RAM, user MAT, and external space) is shown in section 20.4.4, Procedure Program and Storable Area for Programming Data.

The following description assumes the area to be programmed on the user MAT is erased and program data is prepared in the consecutive area. When erasing is not executed, erasing is executed before writing.

128-byte programming is performed in one program processing. When more than 128-byte programming is performed, programming destination address/program data parameter is updated in 128-byte units and programming is repeated.

When less than 128-byte programming is performed, data must total 128 bytes by adding the invalid data. If the dummy data to be added is H'FF, the program processing period can be shortened.

1. Select the on-chip program to be downloaded and specify a download destination

When the PPVS bit of FPCS is set to 1, the programming program is selected. Several programming/erasing programs cannot be selected at one time. If several programs are set, download is not performed and a download error is returned to the SS bit in DPFR. The start address of a download destination is specified by FTDAR.

2. Program H'A5 in FKEY

If H'A5 is not written to FKEY for protection, 1 cannot be set to the SCO bit for download request.

3. 1 is set to the SCO bit of FCCS and then download is executed.

To set 1 to the SCO bit, the following conditions must be satisfied.

— H'A5 is written to FKEY.

— The SCO bit writing is executed in the on-chip RAM.

When the SCO bit is set to 1, download is started automatically. When the SCO bit is returned to the user procedure program, the SCO is cleared to 0. Therefore, the SCO bit cannot be confirmed to be 1 in the user procedure program.

The download result can be confirmed only by the return value of DPFR. Before the SCO bit is set to 1, incorrect determination must be prevented by setting the one byte of the start address (to be used as DPFR) specified by FTDAR to a value other than the return value (e.g. H'FF).

When download is executed, particular interrupt processing, which is accompanied by the bank switch as described below, is performed as an internal microcomputer processing. Four NOP instructions are executed immediately after the instructions that set the SCO bit to 1.

— The user-MAT space is switched to the on-chip program storage area.

— After the selection condition of the download program and the FTDAR setting are checked, the transfer processing to the on-chip RAM specified by FTDAR is executed.

— The SCO bit in FCCS is cleared to 0.

— The return value is set to the DPFR parameter.

— After the on-chip program storage area is returned to the user-MAT space, the user procedure program is returned.

— In the download processing, the values of general registers of the CPU are held.

- In the download processing, any interrupts are not accepted. However, interrupt requests are held. Therefore, when the user procedure program is returned, the interrupts occur.
 - When the level-detection interrupt requests are to be held, interrupts must be input until the download is ended.
 - When hardware standby mode is entered during download processing, the normal download cannot be guaranteed in the on-chip RAM. Therefore, download must be executed again.
 - Since a stack area of 128 bytes at the maximum is used, the area must be allocated before setting the SCO bit to 1.
 - If a flash memory access by the DTC signal is requested during downloading, the operation cannot be guaranteed. Therefore, an access request by the DTC signal must not be generated.
4. FKEY is cleared to H'00 for protection.
5. The value of the DPFR parameter must be checked and the download result must be confirmed.
- Check the value of the DPFR parameter (one byte of start address of the download destination specified by FTDAR). If the value is H'00, download has been performed normally. If the value is not H'00, the source that caused download to fail can be investigated by the description below.
 - If the value of the DPFR parameter is the same as before downloading (e.g. H'FF), the address setting of the download destination in FTDAR may be abnormal. In this case, confirm the setting of the TDER bit (bit 7) in FTDAR.
 - If the value of the DPFR parameter is different from before downloading, check the SS bit (bit 2) and the FK bit (bit 1) in the DPFR parameter to ensure that the download program selection and FKEY setting were normal, respectively.
6. The operating frequency are set to the FPEFEQ parameters for initialization.
- The current frequency of the CPU clock is set to the FPEFEQ parameter (general register ER0).
The settable range of the FPEFEQ parameter is 5 to 33 MHz. When the frequency is set to out of this range, an error is returned to the FPFPR parameter of the initialization program and initialization is not performed. For details on the frequency setting, see the description in 20.3.2 (2) (a), Flash programming/erasing frequency parameter (FPEFEQ).
7. Initialization
- When a programming program is downloaded, the initialization program is also downloaded to the on-chip RAM. There is an entry point of the initialization program in the area from the start address specified by FTDAR + 32 bytes of the on-chip RAM. The subroutine is called and initialization is executed by using the following steps.

MOV . L	#DLTOP+32 , ER2	; Set entry address to ER2
JSR	@ER2	; Call initialization routine
NOP		

- The general registers other than R0L are held in the initialization program.
 - R0L is a return value of the FPFR parameter.
 - Since the stack area is used in the initialization program, 128-byte stack area at the maximum must be allocated in RAM.
 - Interrupts can be accepted during the execution of the initialization program. The program storage area and stack area in the on-chip RAM and register values must not be destroyed.
8. The return value in the initialization program, FPFR (general register R0L) is determined.
 9. All interrupts and the use of a bus master other than the CPU are prohibited. The specified voltage is applied for the specified time when programming or erasing. If interrupts occur or the bus mastership is moved to other than the CPU during this time, the voltage for more than the specified time will be applied and flash memory may be damaged. Therefore, interrupts and bus mastership to other than the CPU, such as to the DTC, are prohibited.

To disable interrupts, bit 7 (I) in the condition code register (CCR) of the CPU should be set to B'1 in interrupt control mode 0 or bits 7 and 6 (I and UI) should be set to B'11 in interrupt control mode 1. Interrupts other than NMI are held and not executed.

The NMI interrupts must be masked within the user system.

The interrupts that are held must be executed after all program processing.

When the bus mastership is moved to other than the CPU, such as to the DTC, the error protection state is entered. Therefore, taking bus mastership by the DTC is prohibited.

10. FKEY must be set to H'5A and the user MAT must be prepared for programming.
11. The parameter which is required for programming is set. The start address of the programming destination of the user MAT (FMPAR) is set to general register ER1. The start address of the program data area (FMPDR) is set to general register ER0.

— Example of the FMPAR setting

FMPAR specifies the programming destination address. When an address other than one in the user MAT area is specified, even if the programming program is executed, programming is not executed and an error is returned to the return value parameter FPFR. Since the unit is 128 bytes, the lower eight bits of the address must be H'00 or H'80 as the boundary of 128 bytes.

— Example of the FMPDR setting

When the storage destination of the program data is flash memory, even if the program execution routine is executed, programming is not executed and an error is returned to the FPFR parameter. In this case, the program data must be transferred to the on-chip RAM and then programming must be executed.

12. Programming

There is an entry point of the programming program in the area from the start address specified by FTDAR + 16 bytes of the on-chip RAM. The subroutine is called and programming is executed by using the following steps.

MOV.L	#DLTOP+16, ER2	; Set entry address to ER2
JSR	@ER2	; Call programming routine
NOP		

— The general registers other than R0L are held in the programming program.

— R0L is a return value of the FPFR parameter.

— Since the stack area is used in the programming program, a stack area of 128 bytes at the maximum must be allocated in RAM.

13. The return value in the programming program, FPFR (general register R0L) is determined.

14. Determine whether programming of the necessary data has finished.

If more than 128 bytes of data are to be programmed, specify FMPAR and FMPDR in 128-byte units, and repeat steps 12 to 14. Increment the programming destination address by 128 bytes and update the programming data pointer correctly. If an address which has already been programmed is written to again, not only will a programming error occur, but also flash memory will be damaged.

15. After programming finishes, clear FKEY and specify software protection.

If this LSI is restarted by a reset immediately after user MAT programming has finished, secure the reset period (period of $\overline{\text{RES}} = 0$) of 100 μs which is longer than normal.

(3) Erasing Procedure in User Program Mode

The procedures for download, initialization, and erasing are shown in figure 20.12.

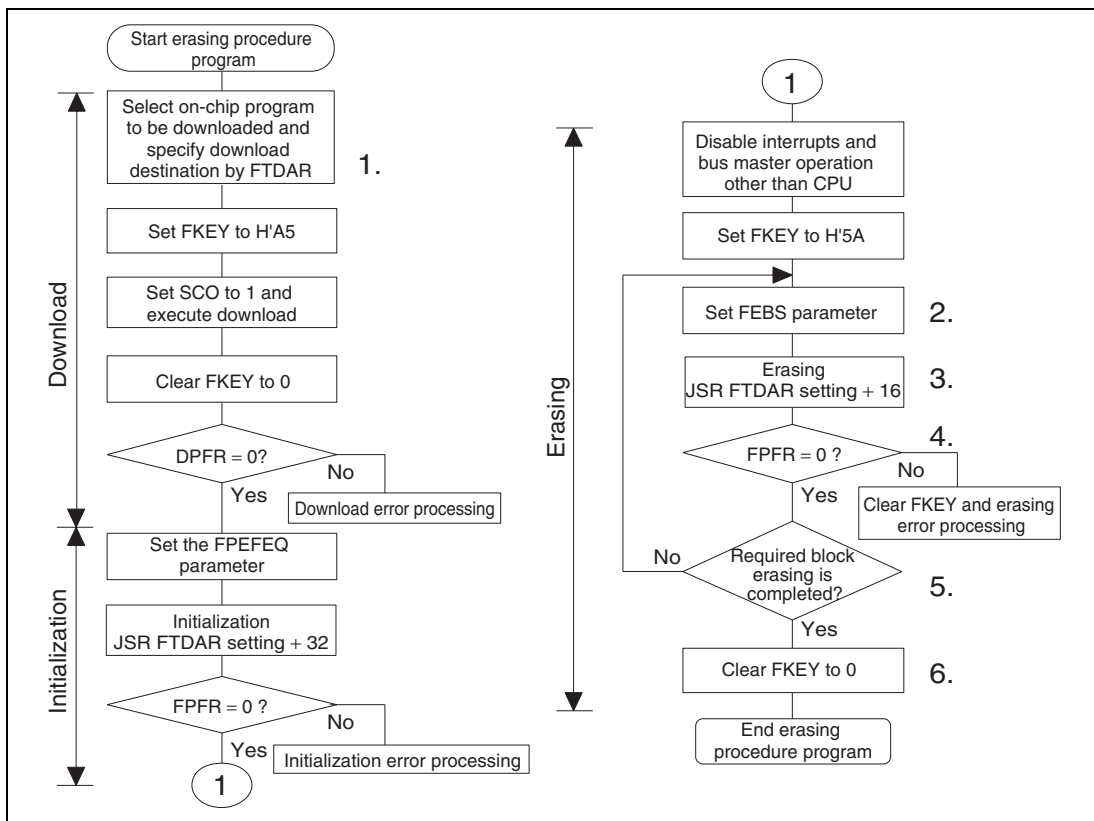

Figure 20.12 Erasing Procedure

The procedure program must be executed in an area other than the user MAT to be erased. Especially the part where the SCO bit in FCCS is set to 1 for downloading must be executed in the on-chip RAM.

The area that can be executed in the steps of the user procedure program (on-chip RAM, user MAT, and external space) is shown in section 20.4.4, Procedure Program and Storable Area for Programming Data.

For the downloaded on-chip program area, refer to the RAM map for programming/erasing in figure 20.10.

A single divided block is erased by one erasing processing. For block divisions, refer to figure 20.4. To erase two or more blocks, update the erase block number and perform the erasing processing for each block.

1. Select the on-chip program to be downloaded

Set the EPVB bit in FECS to 1.

Several programming/erasing programs cannot be selected at one time. If several programs are set, download is not performed and a download error is reported to the SS bit in the DPFR parameter.

Specify the start address of a download destination by FTDAR.

The procedures to be carried out after setting FKEY, e.g. download and initialization, are the same as those in the programming procedure. For details, refer to Programming Procedure in User Program Mode in section 20.4.2, sub-section (2).

The procedures after setting parameters for erasing programs are as follows:

2. Set the FEBS parameter necessary for erasure

Set the erase block number of the user MAT in the flash erase block select parameter FEBS (general register ER0). If a value other than an erase block number of the user MAT is set, no block is erased even though the erasing program is executed, and an error is returned to the return value parameter FPFRR.

3. Erasure

Similar to as in programming, there is an entry point of the erasing program in the area from the start address of a download destination specified by FTDAR + 16 bytes of on-chip RAM. The subroutine is called and erasing is executed by using the following steps.

MOV.L	#DLTOP+16, ER2	; Set entry address to ER2
JSR	@ER2	; Call erasing routine
NOP		

- The general registers other than R0L are held in the erasing program.
- R0L is a return value of the FPFRR parameter.
- Since the stack area is used in the erasing program, a stack area of 128 bytes at the maximum must be allocated in RAM.

4. The return value in the erasing program, FPFRR (general register R0L) is determined.

5. Determine whether erasure of the necessary blocks has completed.

If more than one block is to be erased, update the FEBS parameter and repeat steps 2 to 5. Blocks that have already been erased can be erased again.

6. After erasure completes, clear FKEY and specify software protection.

If this LSI is restarted by a reset immediately after user MAT erasure has completed, secure the reset period (period of RES = 0) of 100 μs which is longer than normal.

(4) Erasing and Programming Procedure in User Program Mode

By changing the on-chip RAM address of the download destination in FTDAR, the erasing program and programming program can be downloaded to separate on-chip RAM areas.

Figure 20.13 shows a repeating procedure of erasing and programming.

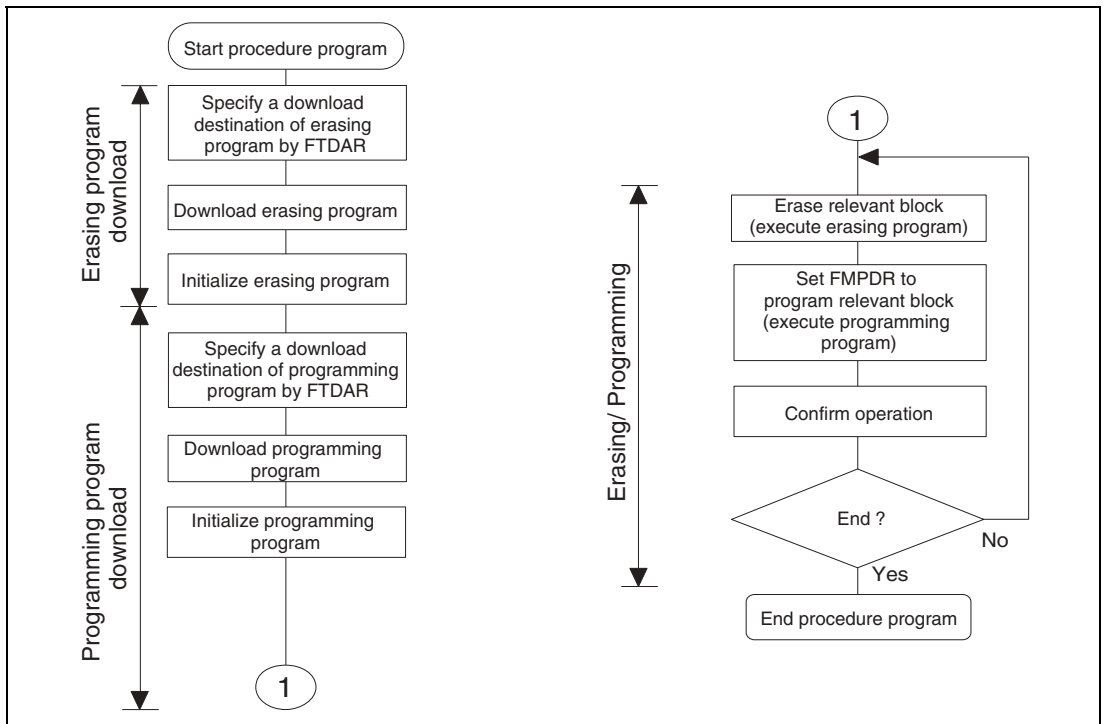

Figure 20.13 Repeating Procedure of Erasing and Programming

In the above procedure, download and initialization are performed only once at the beginning.

In this kind of operation, note the following:

- Be careful not to damage on-chip RAM with overlapped settings.

In addition to the erasing program area and programming program area, areas for the user procedure programs, work area, and stack area are reserved in on-chip RAM. Do not make settings that will overwrite data in these areas.

- Be sure to initialize both the erasing program and programming program.

Initialization by setting the FPEFEQ parameter must be performed for both the erasing program and the programming program. Initialization must be executed for both entry addresses: (download start address for erasing program) + 32 bytes and (download start address for programming program) + 32 bytes.

20.4.3 User Boot Mode

This LSI has user boot mode which is initiated with different mode pin settings than those in boot mode or user program mode. User boot mode is a user-arbitrary boot mode, unlike boot mode that uses the on-chip SCI.

Only the user MAT can be programmed/erased in user boot mode. Programming/erasing of the user boot MAT is only enabled in boot mode or programmer mode.

(1) User Boot Mode Initiation

For the mode pin settings to start up user boot mode, see table 20.5.

When the reset start is executed in user boot mode, the built-in check routine runs. The user MAT and user boot MAT states are checked by this check routine.

While the check routine is running, NMI and all other interrupts cannot be accepted.

Next, processing starts from the execution start address of the reset vector in the user boot MAT. At this point, H'AA is set to FMATS because the execution MAT is the user boot MAT.

(2) User MAT Programming in User Boot Mode

For programming the user MAT in user boot mode, additional processing made by setting FMATS are required: switching from user-boot-MAT selection state to user-MAT selection state, and switching back to user-boot-MAT selection state after programming completes.

Figure 20.14 shows the procedure for programming the user MAT in user boot mode.

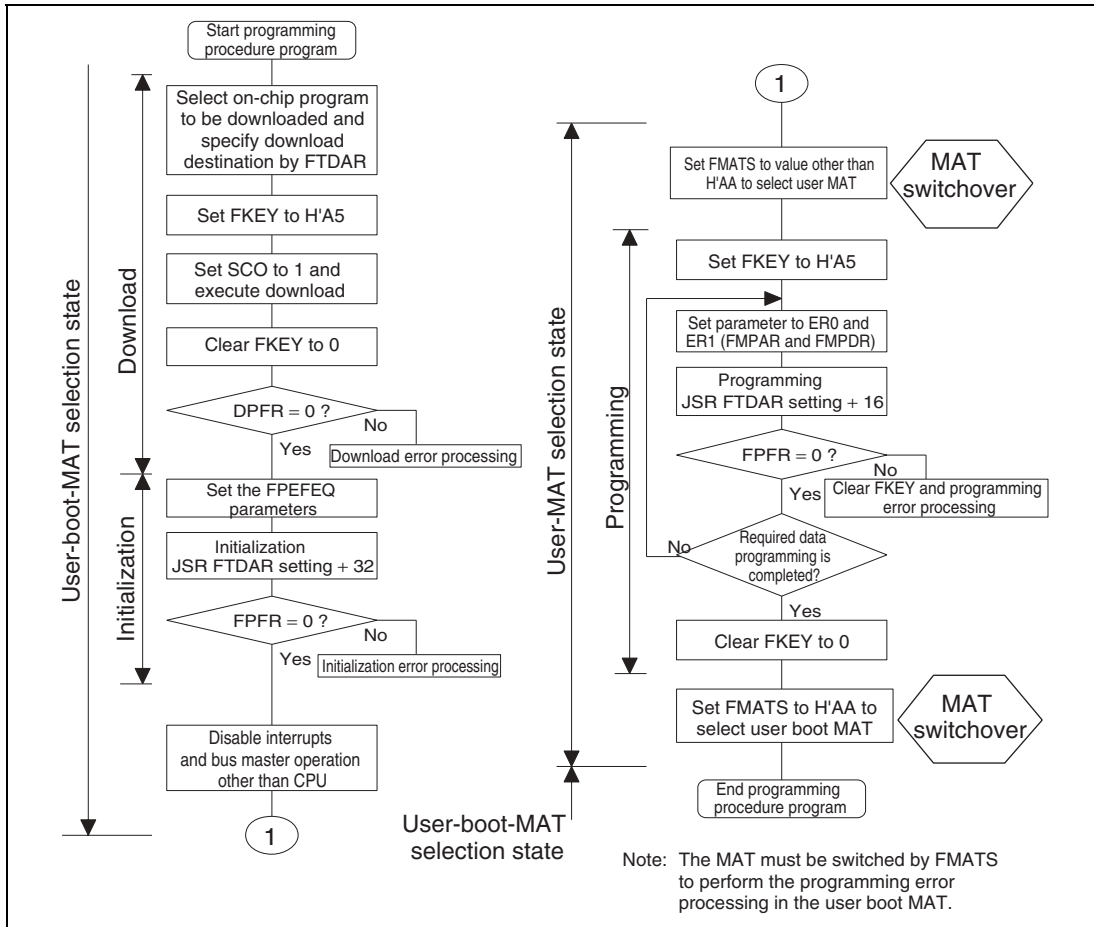

Figure 20.14 Procedure for Programming User MAT in User Boot Mode

The difference between the programming procedures in user program mode and user boot mode is whether the MAT is switched or not as shown in figure 20.14.

In user boot mode, the user boot MAT can be seen in the flash memory space with the user MAT hidden in the background. The user MAT and user boot MAT are switched only while the user MAT is being programmed. Because the user boot MAT is hidden while the user MAT is being programmed, the procedure program must be located in an area other than flash memory. After programming completes, switch the MATs again to return to the first state.

MAT switching is enabled by writing a specific value to FMATS. However note that while the MATs are being switched, the LSI is in an unstable state, e.g. access to a MAT is not allowed until MAT switching is completed, and if an interrupt occurs, from which MAT the interrupt vector is read is undetermined. Perform MAT switching in accordance with the description in section 20.6, Switching between User MAT and User Boot MAT.

Except for MAT switching, the programming procedure is the same as that in user program mode.

The area that can be executed in the steps of the user procedure program (on-chip RAM, user MAT, and external space) is shown in section 20.4.4, Procedure Program and Storable Area for Programming Data.

(3) User MAT Erasing in User Boot Mode

For erasing the user MAT in user boot mode, additional processing made by setting FMATS are required: switching from user-boot-MAT selection state to user-MAT selection state, and switching back to user-boot-MAT selection state after erasing completes.

Figure 20.15 shows the procedure for erasing the user MAT in user boot mode.

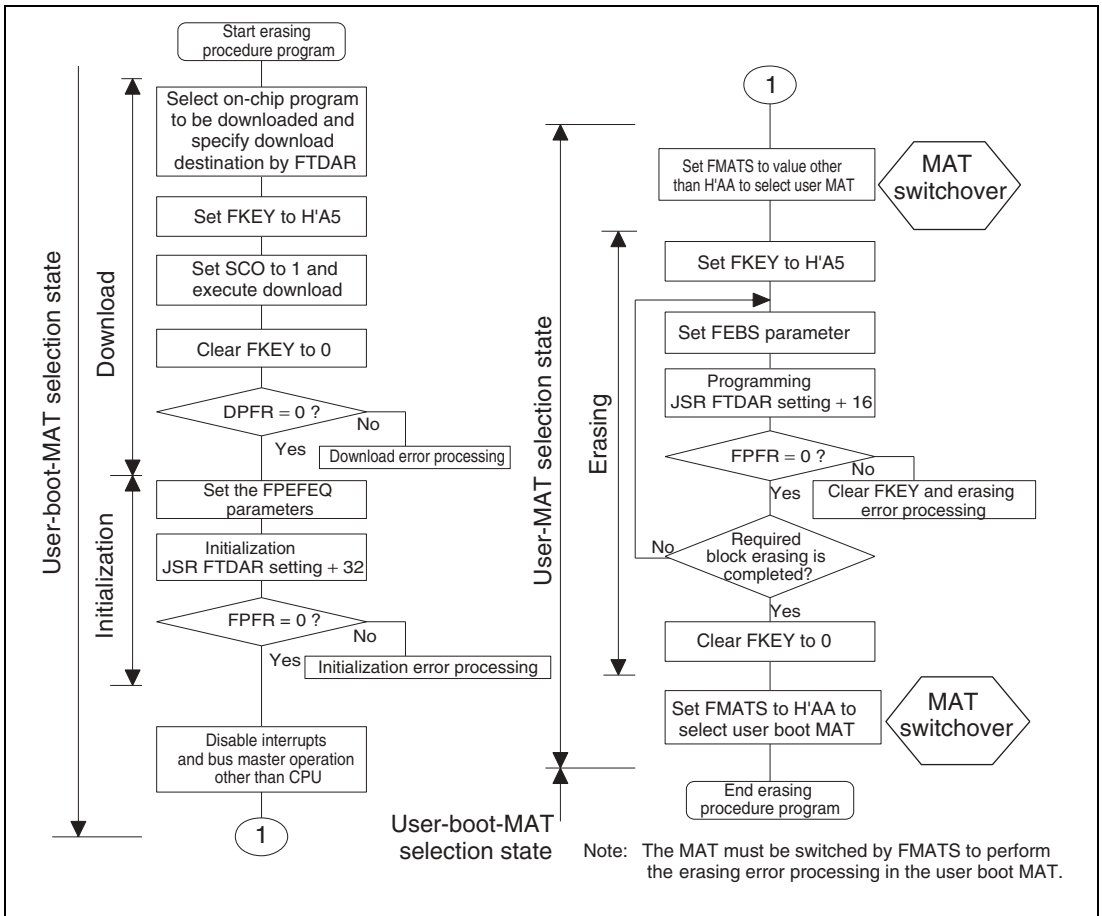

Figure 20.15 Procedure for Erasing User MAT in User Boot Mode

The difference between the erasing procedures in user program mode and user boot mode depends on whether the MAT is switched or not as shown in figure 20.15.

MAT switching is enabled by writing a specific value to FMATS. However note that while the MATs are being switched, the LSI is in an unstable state, e.g. access to a MAT is not allowed until MAT switching is completed, and if an interrupt occurs, from which MAT the interrupt vector is read is undetermined. Perform MAT switching in accordance with the description in section 20.6, Switching between User MAT and User Boot MAT.

Except for MAT switching, the erasing procedure is the same as that in user program mode.

The area that can be executed in the steps of the user procedure program (on-chip RAM, user MAT, and external space) is shown in section 20.4.4, Procedure Program and Storable Area for Programming Data.

20.4.4 Procedure Program and Storable Area for Programming Data

In the descriptions in the previous section, the programming/erasing procedure programs and storable areas for program data are assumed to be in the on-chip RAM. However, the program and the data can be stored in and executed from other areas, such as part of flash memory which is not to be programmed or erased, or somewhere in the external address space.

(1) Conditions that Apply to Programming/Erasing

1. The on-chip programming/erasing program is downloaded from the address in the on-chip RAM specified by FTDAR, therefore, this area is not available for use.
2. The on-chip programming/erasing program will use 128 bytes at the maximum as a stack. So, make sure that this area is secured.
3. Download by setting the SCO bit to 1 will lead to switching of the MAT. If, therefore, this operation is used, it should be executed from the on-chip RAM.
4. The flash memory is accessible until the start of programming or erasing, that is, until the result of downloading has been determined. When in a mode in which the external address space is not accessible, such as single-chip mode, the required procedure programs, NMI handling vector and NMI handler should be transferred to the on-chip RAM before programming/erasing of the flash memory starts.
5. The flash memory is not accessible during programming/erasing operations, therefore, the operation program is downloaded to the on-chip RAM to be executed. The NMI-handling vector and programs such as that which activate the operation program, and NMI handler should thus be stored in on-chip memory other than flash memory or the external address space.
6. After programming/erasing, the flash memory should be inhibited until FKEY is cleared. The reset state ($\overline{\text{RES}} = 0$) must be in place for more than 100 μs when the LSI mode is changed to reset on completion of a programming/erasing operation.

Transitions to the reset state, and hardware standby mode are inhibited during programming/erasing. When the reset signal is accidentally input to the chip, a longer period in the reset state than usual (100 μ s) is needed before the reset signal is released.

7. Switching of the MATs by FMATS should be needed when programming/erasing of the user boot MAT is operated in user-boot mode. The program which switches the MATs should be executed from the on-chip RAM. See section 20.6, Switching between User MAT and User Boot MAT. Please make sure you know which MAT is selected when switching between them.
8. When the data storable area indicated by programming parameter FMPDR is within the flash memory area, an error will occur even when the data stored is normal. Therefore, the data should be transferred to the on-chip RAM to place the address that FMPDR indicates in an area other than the flash memory.

In consideration of these conditions, there are three factors; operating mode, the bank structure of the user MAT, and operations.

The areas in which the programming data can be stored for execution are shown in tables.

Table 20.7 Executable MAT

Operation	Initiated Mode	
	User Program Mode	User Boot Mode*
Programming	Table 20.8 (1)	Table 20.8 (3)
Erasing	Table 20.8 (2)	Table 20.8 (4)

Note: * Programming/Erasing is possible to user MATs.

Table 20.8 (1) Useable Area for Programming in User Program Mode

Item	Storable /Executable Area			Selected MAT	
	On-chip RAM	User MAT	External Space (Expanded Mode)	User MAT	Embedded Program Storage Area
Storage Area for Program Data	○	×*	○	—	—
Operation for Selection of On-chip Program to be Downloaded	○	○	○	○	
Operation for Writing H'A5 to FKEY	○	○	○	○	
Execution of Writing SCO = 1 to FCCS (Download)	○	×	×		○
Operation for FKEY Clear	○	○	○	○	
Determination of Download Result	○	○	○	○	
Operation for Download Error	○	○	○	○	
Operation for Settings of Initial Parameter	○	○	○	○	
Execution of Initialization	○	×	×	○	
Determination of Initialization Result	○	○	○	○	
Operation for Initialization Error	○	○	○	○	
NMI Handling Routine	○	×	○	○	
Operation for Inhibit of Interrupt	○	○	○	○	
Operation for Writing H'5A to FKEY	○	○	○	○	
Operation for Settings of Program Parameter	○	×	○	○	

Item	Storable /Executable Area			Selected MAT	
	On-chip RAM	User MAT	External Space (Expanded Mode)	User MAT	Embedded Program Storage Area
Execution of Programming	○	×	×	○	
Determination of Program Result	○	×	○	○	
Operation for Program Error	○	×	○	○	
Operation for FKEY Clear	○	×	○	○	

Note: * Transferring the data to the on-chip RAM enables this area to be used.

Table 20.8 (2) Useable Area for Erasure in User Program Mode

Item	Storable /Executable Area			Selected MAT	
	On-chip RAM	User MAT	External Space (Expanded Mode)	User MAT	Embedded Program Storage Area
Operation for Selection of On-chip Program to be Downloaded	○	○	○	○	
Operation for Writing H'A5 to FKEY	○	○	○	○	
Execution of Writing SCO = 1 to FCCS (Download)	○	×	×		○
Operation for FKEY Clear	○	○	○	○	
Determination of Download Result	○	○	○	○	
Operation for Download Error	○	○	○	○	
Operation for Settings of Initial Parameter	○	○	○	○	
Execution of Initialization	○	×	×	○	
Determination of Initialization Result	○	○	○	○	
Operation for Initialization Error	○	○	○	○	
NMI Handling Routine	○	×	○	○	
Operation for Inhibit of Interrupt	○	○	○	○	
Operation for Writing H'5A to FKEY	○	○	○	○	
Operation for Settings of Erasure Parameter	○	×	○	○	
Execution of Erasure	○	×	×	○	
Determination of Erasure Result	○	×	○	○	

Item	Storable /Executable Area			Selected MAT	
	On-chip RAM	User MAT	External Space (Expanded Mode)	User MAT	Embedded Program Storage Area
Operation for Erasure Error	○	×	○	○	
Operation for FKEY Clear	○	×	○	○	

Table 20.8 (3) Useable Area for Programming in User Boot Mode

Item	Storable/Executable Area			Selected MAT		
	On-chip RAM	User Boot MAT	External Space (Expanded Mode)	User MAT	User Boot MAT	Embedded Program Storage Area
Storage Area for Program Data	○	×* ¹	○	—	—	—
Operation for Selection of On-chip Program to be Downloaded	○	○	○		○	
Operation for Writing H'A5 to FKEY	○	○	○		○	
Execution of Writing SCO = 1 to FCCS (Download)	○	×	×			○
Operation for FKEY Clear	○	○	○		○	
Determination of Download Result	○	○	○		○	
Operation for Download Error	○	○	○		○	
Operation for Settings of Initial Parameter	○	○	○		○	
Execution of Initialization	○	×	×		○	
Determination of Initialization Result	○	○	○		○	
Operation for Initialization Error	○	○	○		○	
NMI Handling Routine	○	×	○		○	
Operation for Interrupt Inhibit	○	○	○		○	
Switching MATs by FMATS	○	×	×	○		
Operation for Writing H'5A to FKEY	○	×	○	○		

Item	Storable/Executable Area			Selected MAT		
	On-chip RAM	User Boot MAT	External Space (Expanded Mode)	User MAT	User Boot MAT	Embedded Program Storage Area
Operation for Settings of Program Parameter	○	×	○	○		
Execution of Programming	○	×	×	○		
Determination of Program Result	○	×	○	○		
Operation for Program Error	○	×*2	○	○		
Operation for FKEY Clear	○	×	○	○		
Switching MATs by FMATS	○	×	×		○	

- Notes: 1. Transferring the data to the on-chip RAM enables this area to be used.
2. Switching FMATS by a program in the on-chip RAM enables this area to be used.

Table 20.8 (4) Useable Area for Erasure in User Boot Mode

Item	Storable/Executable Area			Selected MAT		
	On-chip RAM	User Boot MAT	External Space (Expanded Mode)	User MAT	User Boot MAT	Embedded Program Storage Area
Operation for Selection of On-chip Program to be Downloaded	○	○	○		○	
Operation for Writing H'A5 to FKEY	○	○	○		○	
Execution of Writing SCO = 1 to FCCS (Download)	○	×	×			○
Operation for FKEY Clear	○	○	○		○	
Determination of Download Result	○	○	○		○	
Operation for Download Error	○	○	○		○	
Operation for Settings of Initial Parameter	○	○	○		○	
Execution of Initialization	○	×	×		○	
Determination of Initialization Result	○	○	○		○	
Operation for Initialization Error	○	○	○		○	
NMI Handling Routine	○	×	○		○	
Operation for Interrupt Inhibit	○	○	○		○	
Switching MATs by FMATS	○	×	×		○	
Operation for Writing H'5A to FKEY	○	×	○	○		
Operation for Settings of Erasure Parameter	○	×	○	○		

Item	Storable/Executable Area			Selected MAT		
	On-chip RAM	User Boot MAT	External Space (Expanded Mode)	User MAT	User Boot MAT	Embedded Program Storage Area
Execution of Erasure	○	×	×	○		
Determination of Erasure Result	○	×	○	○		
Operation for Erasure Error	○	×*	○	○		
Operation for FKEY Clear	○	×	○	○		
Switching MATs by FMATS	○	×	×	○		

Note: * Switching FMATS by a program in the on-chip RAM enables this area to be used.

20.5 Protection

There are three kinds of flash memory program/erase protection: hardware, software, and error protection.

20.5.1 Hardware Protection

Programming and erasing of flash memory is forcibly disabled or suspended by hardware protection. In this state, the downloading of an on-chip program and initialization are possible. However, an activated program for programming or erasure cannot program or erase locations in a user MAT, and the error in programming/erasing is reported in the parameter FPFR.

Table 20.9 Hardware Protection

Item	Description	Function to be Protected	
		Download	Program/Erase
FWE pin protection	<ul style="list-style-type: none">When a low level signal is input to the FWE pin, the FWE bit in FCCS is cleared and the program/erase-protected state is entered.	—	○
Reset/standby protection	<ul style="list-style-type: none">The program/erase interface registers are initialized in the reset state (including a reset by the WDT) and standby mode and the program/erase-protected state is entered.The reset state will not be entered by a reset using the $\overline{\text{RES}}$ pin unless the $\overline{\text{RES}}$ pin is held low until oscillation has stabilized after power is initially supplied. In the case of a reset during operation, hold the $\overline{\text{RES}}$ pin low for the RES pulse width that is specified in the section on AC characteristics section. If a reset is input during programming or erasure, data values in the flash memory are not guaranteed. In this case, execute erasure and then execute program again.	○	○

20.5.2 Software Protection

Software protection is set up in any of two ways: by disabling the downloading of on-chip programs for programming and erasing and by means of a key code.

Table 20.10 Software Protection

Item	Description	Function to be Protected	
		Download	Program/Erase
Protection by the SCO bit	<ul style="list-style-type: none">The program/erase-protected state is entered by clearing the SCO bit in FCCS which disables the downloading of the programming/erasing programs.	○	○
Protection by the FKEY register	<ul style="list-style-type: none">Downloading and programming/erasing are disabled unless the required key code is written in FKEY. Different key codes are used for downloading and for programming/erasing.	○	○

20.5.3 Error Protection

Error protection is a mechanism for aborting programming or erasure when an error occurs, in the form of the microcomputer entering runaway during programming/erasing of the flash memory or operations that are not according to the established procedures for programming/erasing. Aborting programming or erasure in such cases prevents damage to the flash memory due to excessive programming or erasing.

If the microcomputer malfunctions during programming/erasing of the flash memory, the FLER bit in the FCCS register is set to 1 and the error-protection state is entered, and this aborts the programming or erasure.

The FLER bit is set in the following conditions:

1. When an interrupt such as NMI occurs during programming/erasing.
2. When the flash memory is read during programming/erasing (including a vector read or an instruction fetch).
3. When a SLEEP instruction (including software-standby mode) is executed during programming/erasing.
4. When a bus master other than the CPU, such as the DTC, gets bus mastership during programming/erasing.

Error protection is cancelled only by a reset or by hardware-standby mode. Note that the reset should be released after the reset period of 100 μ s which is longer than normal. Since high voltages are applied during programming/erasing of the flash memory, some voltage may remain after the error-protection state has been entered. For this reason, it is necessary to reduce the risk of damage to the flash memory by extending the reset period so that the charge is released.

The state-transition diagram in figure 20.16 shows transitions to and from the error-protection state.

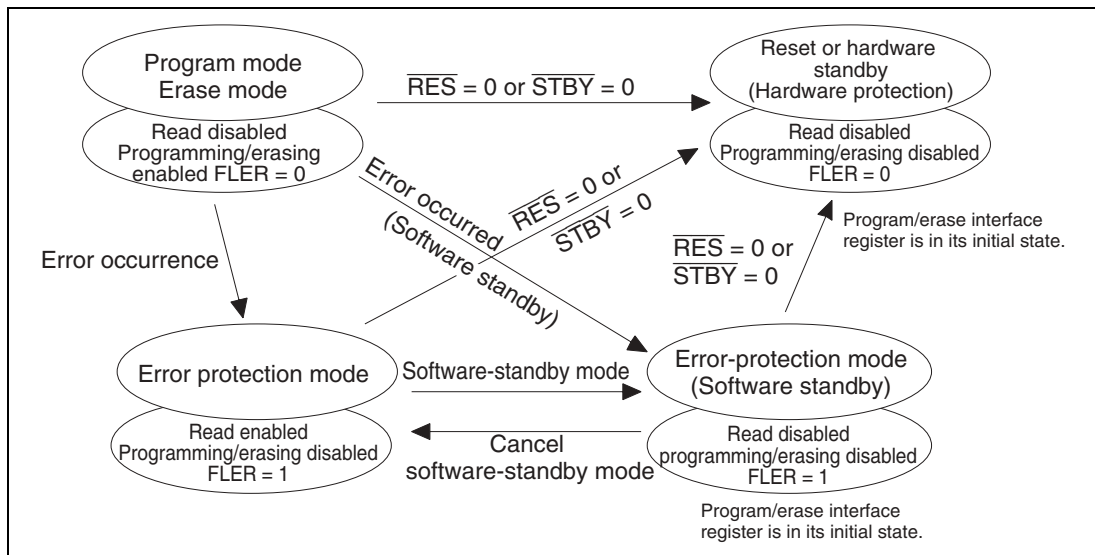

Figure 20.16 Transitions to Error-Protection State

20.6 Switching between User MAT and User Boot MAT

It is possible to alternate between the user MAT and user boot MAT. However, the following procedure is required because these MATs are allocated to address 0. (Switching to the user boot MAT disables programming and erasing. Programming of the user boot MAT should take place in boot mode or programmer mode.)

1. MAT switching by FMATS should always be executed from the on-chip RAM.
2. To ensure that the MAT that has been switched to is accessible, execute four NOP instructions in the on-chip RAM immediately after writing to FMATS of the on-chip RAM (this prevents access to the flash memory during MAT switching).
3. If an interrupt has occurred during switching, there is no guarantee of which memory MAT is being accessed. Always mask the maskable interrupts before switching between MATs. In addition, configure the system so that NMI interrupts do not occur during MAT switching.
4. After the MATs have been switched, take care because the interrupt vector table will also have been switched. If interrupt processing is to be the same before and after MAT switching, transfer the interrupt-processing routines to the on-chip RAM and set the WEINTE bit in FCCS to place the interrupt-vector table in the on-chip RAM.
5. Memory sizes of the user MAT and user boot MAT are different. When accessing the user boot MAT, do not access addresses above the top of its 8-kbyte memory space. If access goes beyond the 8-kbyte space, the values read are undefined.

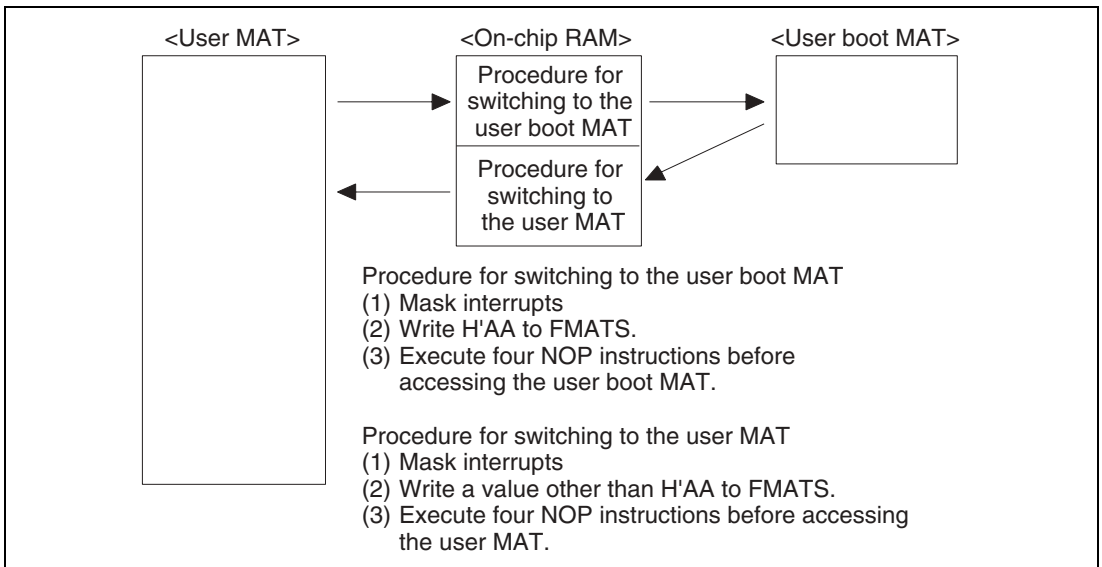

Figure 20.17 Switching between the User MAT and User Boot MAT

20.7 Programmer Mode

Along with its on-board programming mode, this LSI also has a programmer mode as a further mode for the programming and erasing of programs and data. In the programmer mode, a general-purpose PROM programmer can freely be used to write programs to the on-chip ROM. Program/erase is possible on the user MAT and user boot MAT*¹. The PROM programmer must support microcomputers with 256 or 512-kbyte flash memory as a device type*². Figure 20.18 shows a memory map in programmer mode.

A status-polling system is adopted for operation in automatic program, automatic erase, and status-read modes. In the status-read mode, details of the system's internal signals are output after execution of automatic programming or automatic erasure. In programmer mode, provide a 12-MHz input-clock signal.

- Notes: 1. For the PROM programmer and the version of its program, see the instruction manuals for socket adapter.
2. In this LSI, set the programming voltage of the PROM programmer to 3.3 V.

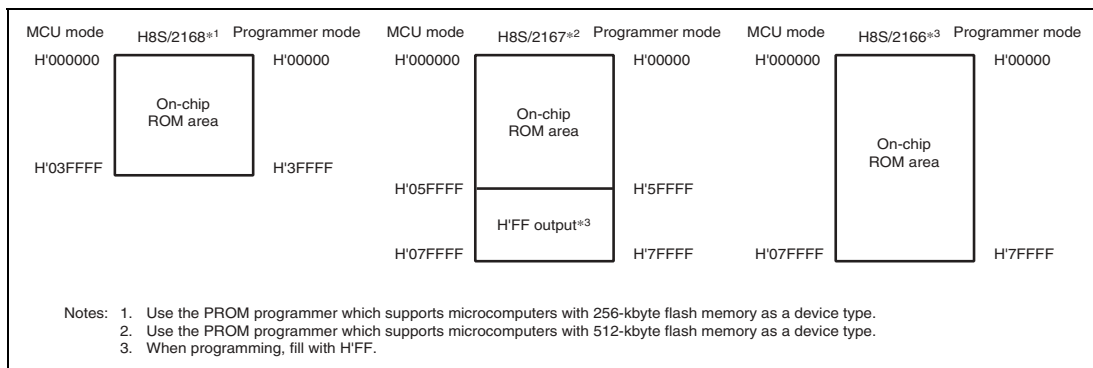

Figure 20.18 Memory Map in Programmer Mode

20.8 Serial Communication Interface Specification for Boot Mode

Initiating boot mode enables the boot program to communicate with the host by using the internal SCI. The serial communication interface specification is shown below.

(1) Status

The boot program has three states.

1. Bit-Rate-Adjustment State

In this state, the boot program adjusts the bit rate to communicate with the host. Initiating boot mode enables starting of the boot program and entry to the bit-rate-adjustment state. The program receives the command from the host to adjust the bit rate. After adjusting the bit rate, the program enters the inquiry/selection state.

2. Inquiry/Selection State

In this state, the boot program responds to inquiry commands from the host. The device name, clock mode, and bit rate are selected. After selection of these settings, the program is made to enter the programming/erasing state by the command for a transition to the programming/erasing state. The program transfers the libraries required for erasure to the on-chip RAM and erases the user MATs and user boot MATs before the transition.

3. Programming/erasing state

Programming and erasure by the boot program take place in this state. The boot program is made to transfer the programming/erasing programs to the RAM by commands from the host. Sum checks and blank checks are executed by sending these commands from the host.

These boot program states are shown in figure 20.19.

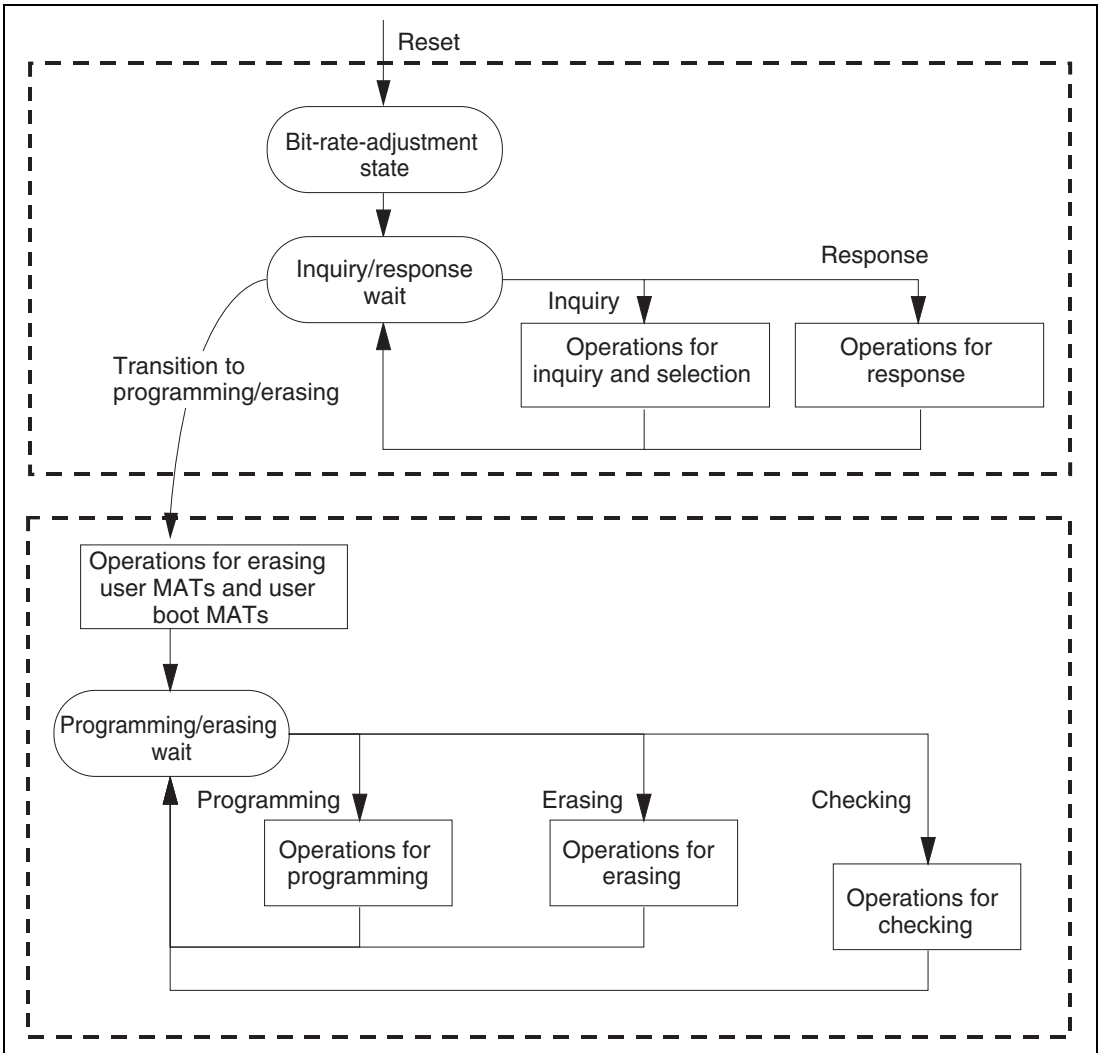

Figure 20.19 Boot Program States

(2) Bit-Rate-Adjustment State

The bit rate is calculated by measuring the period of transfer of a low-level byte (H'00) from the host. The bit rate can be changed by the command for a new bit rate selection. After the bit rate has been adjusted, the boot program enters the inquiry and selection state. The bit-rate-adjustment sequence is shown in figure 20.20.

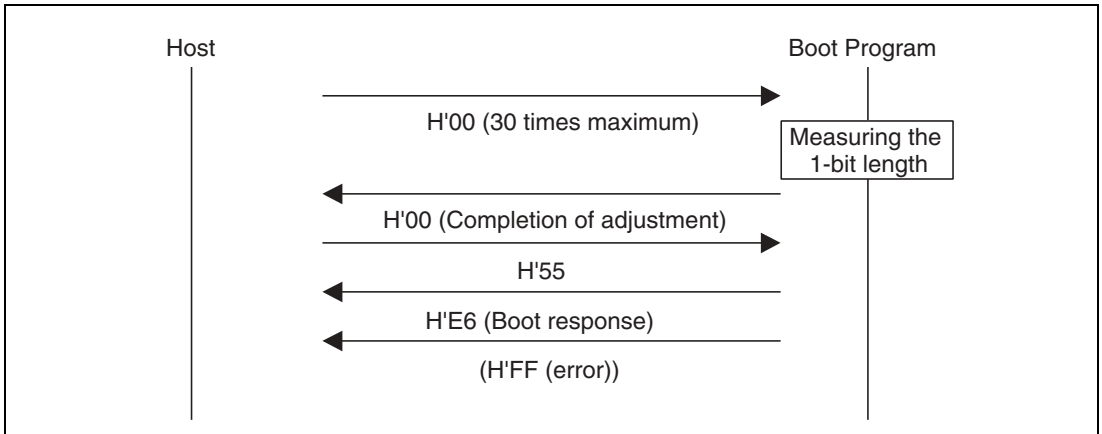

Figure 20.20 Bit-Rate-Adjustment Sequence

(3) Communications Protocol

After adjustment of the bit rate, the protocol for communications between the host and the boot program is as shown below.

1. 1-byte commands and 1-byte responses

These commands and responses are comprised of a single byte. These consist of the inquiries and the ACK for successful completion.

2. n-byte commands or n-byte responses

These commands and responses are comprised of n bytes of data. These are selections and responses to inquiries.

The amount of programming data is not included under this heading because it is determined in another command.

3. Error response

The error response is a response to inquiries. It consists of an error response and an error code and comes two bytes.

4. Programming of 128 bytes

The size is not specified in commands. The size of n is indicated in response to the programming unit inquiry.

5. Memory read response

This response consists of 4 bytes of data.

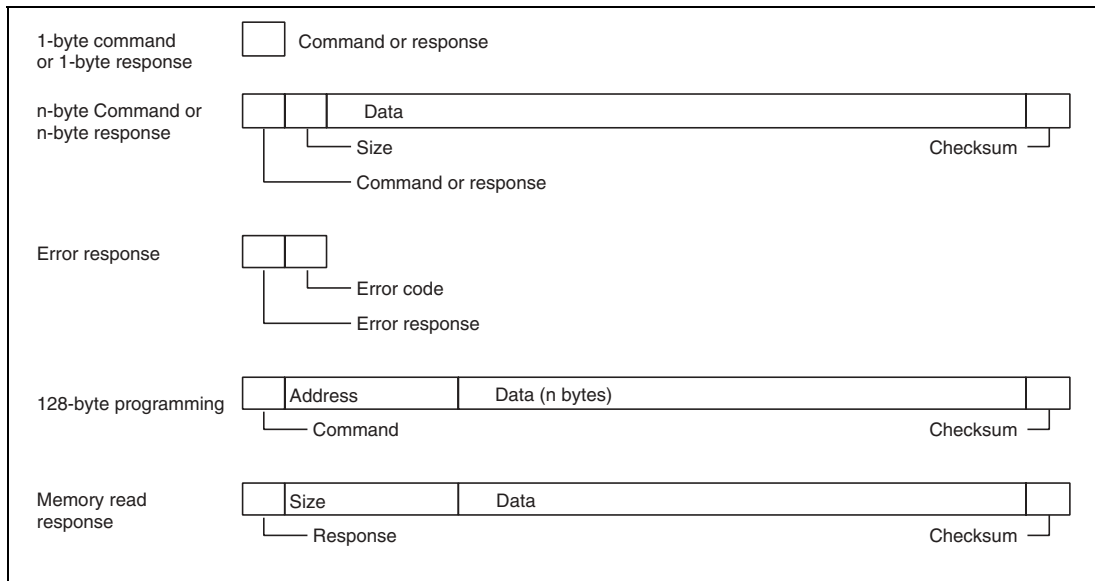

Figure 20.21 Communication Protocol Format

- **Command (1 byte):** Commands including inquiries, selection, programming, erasing, and checking
- **Response (1 byte):** Response to an inquiry
- **Size (1 byte):** The amount of data for transmission excluding the command, amount of data, and checksum
- **Checksum (1 byte):** The checksum is calculated so that the total of all values from the command byte to the SUM byte becomes H'00.
- **Data (n bytes):** Detailed data of a command or response
- **Error response (1 byte):** Error response to a command
- **Error code (1 byte):** Type of the error
- **Address (4 bytes):** Address for programming
- **Data (n bytes):** Data to be programmed (the size is indicated in the response to the programming unit inquiry.)
- **Size (4 bytes):** 4-byte response to a memory read

(4) Inquiry and Selection States

The boot program returns information from the flash memory in response to the host's inquiry commands and sets the device code, clock mode, and bit rate in response to the host's selection command.

Inquiry and selection commands are listed below.

Table 20.11 Inquiry and Selection Commands

Command	Command Name	Description
H'20	Supported Device Inquiry	Inquiry regarding device codes
H'10	Device Selection	Selection of device code
H'21	Clock Mode Inquiry	Inquiry regarding numbers of clock modes and values of each mode
H'11	Clock Mode Selection	Indication of the selected clock mode
H'22	Multiplication Ratio Inquiry	Inquiry regarding the number of frequency-multiplied clock types, the number of multiplication ratios, and the values of each multiple
H'23	Operating Clock Frequency Inquiry	Inquiry regarding the maximum and minimum values of the main clock and peripheral clocks
H'24	User Boot MAT Information Inquiry	Inquiry regarding the number of user boot MATs and the start and last addresses of each MAT
H'25	User MAT Information Inquiry	Inquiry regarding the a number of user MATs and the start and last addresses of each MAT
H'26	Block for Erasing Information Inquiry	Inquiry regarding the number of blocks and the start and last addresses of each block
H'27	Programming Unit Inquiry	Inquiry regarding the unit of programming data
H'3F	New Bit Rate Selection	Selection of new bit rate
H'40	Transition to Programming/Erasing State	Erasing of user MAT and user boot MAT, and entry to programming/erasing state
H'4F	Boot Program Status Inquiry	Inquiry into the operated status of the boot program

The selection commands, which are device selection (H'10), clock mode selection (H'11), and new bit rate selection (H'3F), should be sent from the host in that order. These commands will certainly be needed. When two or more selection commands are sent at once, the last command will be valid.

All of these commands, except for the boot program status inquiry command (H'4F), will be valid until the boot program receives the programming/erasing transition (H'40). The host can choose

the needed commands out of the commands and inquiries listed above. The boot program status inquiry command (H'4F) is valid after the boot program has received the programming/erasing transition command (H'40).

(a) Supported Device Inquiry

The boot program will return the device codes of supported devices and the product code in response to the supported device inquiry.

Command

H'20

- Command, H'20, (1 byte): Inquiry regarding supported devices

Response	H'30	Size	Number of devices	
	Number of characters	Device code		Product name
	...			
	SUM			

- Response, H'30, (1 byte): Response to the supported device inquiry
- Size (1 byte): Number of bytes to be transmitted, excluding the command, size, and checksum, that is, the amount of data contributes by the number of devices, characters, device codes and product names
- Number of devices (1 byte): The number of device types supported by the boot program
- Number of characters (1 byte): The number of characters in the device codes and boot program's name
- Device code (4 bytes): ASCII code of the supporting product
- Product name (n bytes): Type name of the boot program in ASCII-coded characters
- SUM (1 byte): Checksum

The checksum is calculated so that the total number of all values from the command byte to the SUM byte becomes H'00.

(b) Device Selection

The boot program will set the supported device to the specified device code. The program will return the selected device code in response to the inquiry after this setting has been made.

Command

H'10	Size	Device code	SUM
------	------	-------------	-----

- Command, H'10, (1 byte): Device selection
- Size (1 byte): Amount of device-code data
This is fixed at 2
- Device code (4 bytes): Device code (ASCII code) returned in response to the supported device inquiry
- SUM (1 byte): Checksum

Response

H'06

- Response, H'06, (1 byte): Response to the device selection command
ACK will be returned when the device code matches.

Error response

H'90	ERROR
------	-------

- Error response, H'90, (1 byte): Error response to the device selection command
ERROR : (1 byte): Error code
H'11: Sum check error
H'21: Device code error, that is, the device code does not match

(c) Clock Mode Inquiry

The boot program will return the supported clock modes in response to the clock mode inquiry.

Command

H'21

- Command, H'21, (1 byte): Inquiry regarding clock mode

Response

H'31	Size	Number of modes	Mode	...	SUM
------	------	-----------------	------	-----	-----

- Response, H'31, (1 byte): Response to the clock-mode inquiry
- Size (1 byte): Amount of data that represents the number of modes and modes
- Number of clock modes (1 byte): The number of supported clock modes
H'00 indicates no clock mode or the device allows to read the clock mode.
- Mode (1 byte): Values of the supported clock modes (i.e. H'01 means clock mode 1.)
- SUM (1 byte): Checksum

(d) Clock Mode Selection

The boot program will set the specified clock mode. The program will return the selected clock-mode information after this setting has been made.

The clock-mode selection command should be sent after the device-selection commands.

Command

H'11	Size	Mode	SUM
------	------	------	-----

- Command, H'11, (1 byte): Selection of clock mode
- Size (1 byte): Amount of data that represents the modes
- Mode (1 byte): A clock mode returned in reply to the supported clock mode inquiry.
- SUM (1 byte): Checksum

Response

H'06

- Response, H'06, (1 byte): Response to the clock mode selection command
ACK will be returned when the clock mode matches.

Error Response	H'91	ERROR
----------------	------	-------

- Error response, H'91, (1 byte) : Error response to the clock mode selection command
- ERROR : (1 byte): Error code
H'11: Checksum error
H'22: Clock mode error, that is, the clock mode does not match.

Even if the clock mode numbers are H'00 and H'01 by a clock mode inquiry, the clock mode must be selected using these respective values.

(e) Multiplication Ratio Inquiry

The boot program will return the supported multiplication and division ratios.

Command	H'22
---------	------

- Command, H'22, (1 byte): Inquiry regarding multiplication ratio

Response	H'32	Size	Number of types					
	Number of multiplication ratios	Multiplication ratio	...					
	...							
	SUM							

- Response, H'32, (1 byte): Response to the multiplication ratio inquiry
- Size (1 byte): The amount of data that represents the number of clock sources and multiplication ratios and the multiplication ratios
- Number of types (1 byte): The number of supported multiplied clock types (e.g. when there are two multiplied clock types, which are the main and peripheral clocks, the number of types will be H'02.)
- Number of multiplication ratios (1 byte): The number of multiplication ratios for each type (e.g. the number of multiplication ratios to which the main clock can be set and the peripheral clock can be set.)
- Multiplication ratio (1 byte)
Multiplication ratio: The value of the multiplication ratio (e.g. when the clock-frequency multiplier is four, the value of multiplication ratio will be H'04.)
Division ratio: The inverse of the division ratio, i.e. a negative number (e.g. when the clock is divided by two, the value of division ratio will be H'FE. H'FE = D'-2)
The number of multiplication ratios returned is the same as the number of multiplication ratios and as many groups of data are returned as there are types.
- SUM (1 byte): Checksum

(f) Operating Clock Frequency Inquiry

The boot program will return the number of operating clock frequencies, and the maximum and minimum values.

Command

H'23

- Command, H'23, (1 byte): Inquiry regarding operating clock frequencies

Response	H'33	Size	Number of operating clock frequencies
	Minimum value of operating clock frequency		Maximum value of operating clock frequency
	...		
	SUM		

- Response, H'33, (1 byte): Response to operating clock frequency inquiry
- Size (1 byte): The number of bytes that represents the minimum values, maximum values, and the number of frequencies.
- Number of operating clock frequencies (1 byte): The number of supported operating clock frequency types
(e.g. when there are two operating clock frequency types, which are the main and peripheral clocks, the number of types will be H'02.)
- Minimum value of operating clock frequency (2 bytes): The minimum value of the multiplied or divided clock frequency.
The minimum and maximum values represent the values in MHz, valid to the hundredths place of MHz, and multiplied by 100. (e.g. when the value is 20.00 MHz, it will be 2000, which is H'07D0.)
- Maximum value (2 bytes): Maximum value among the multiplied or divided clock frequencies.
There are as many pairs of minimum and maximum values as there are operating clock frequencies.
- SUM (1 byte): Checksum

(g) User Boot MAT Information Inquiry

The boot program will return the number of user boot MATs and their addresses.

Command

H'24

- Command, H'24, (1 byte): Inquiry regarding user boot MAT information

Response	H'34	Size	Number of areas	
	Area-start address			Area-last address
	...			
	SUM			

- Response, H'34, (1 byte): Response to user boot MAT information inquiry
- Size (1 byte): The number of bytes that represents the number of areas, area-start addresses, and area-last address
- Number of Areas (1 byte): The number of consecutive user boot MAT areas
When user boot MAT areas are consecutive, the number of areas returned is H'01.
- Area-start address (4 byte): Start address of the area
- Area-last address (4 byte): Last address of the area
There are as many groups of data representing the start and last addresses as there are areas.
- SUM (1 byte): Checksum

(h) User MAT Information Inquiry

The boot program will return the number of user MATs and their addresses.

Command

H'25

- Command, H'25, (1 byte): Inquiry regarding user MAT information

Response	H'35	Size	Number of areas	
	Start address area			Last address area
	...			
	SUM			

- Response, H'35, (1 byte): Response to the user MAT information inquiry
- Size (1 byte): The number of bytes that represents the number of areas, area-start address and area-last address
- Number of areas (1 byte): The number of consecutive user MAT areas
When the user MAT areas are consecutive, the number of areas is H'01.
- Area-start address (4 bytes): Start address of the area
- Area-last address (4 bytes): Last address of the area
There are as many groups of data representing the start and last addresses as there are areas.
- SUM (1 byte): Checksum

(i) Erased Block Information Inquiry

The boot program will return the number of erased blocks and their addresses.

Command

H'26

- Command, H'26, (1 byte): Inquiry regarding erased block information

Response

H'36	Size	Number of blocks	
Block start address			Block last address
...			
SUM			

- Response, H'36, (1 byte): Response to the number of erased blocks and addresses
- Size (three bytes): The number of bytes that represents the number of blocks, block-start addresses, and block-last addresses.
- Number of blocks (1 byte): The number of erased blocks
- Block start address (4 bytes): Start address of a block
- Block last Address (4 bytes): Last address of a block
There are as many groups of data representing the start and last addresses as there are areas.
- SUM (1 byte): Checksum

(j) Programming Unit Inquiry

The boot program will return the programming unit used to program data.

Command

H'27

- Command, H'27, (1 byte): Inquiry regarding programming unit

Response

H'37	Size	Programming unit	SUM
------	------	------------------	-----

- Response, H'37, (1 byte): Response to programming unit inquiry
- Size (1 byte): The number of bytes that indicate the programming unit, which is fixed to 2
- Programming unit (2 bytes): A unit for programming
This is the unit for reception of programming.
- SUM (1 byte): Checksum

(k) New Bit-Rate Selection

The boot program will set a new bit rate and return the new bit rate.

This selection should be sent after sending the clock mode selection command.

Command	H'3F	Size	Bit rate	Input frequency
	Number of multiplication ratios	Multiplication ratio 1	Multiplication ratio 2	
	SUM			

- Command, H'3F, (1 byte): Selection of new bit rate
- Size (1 byte): The number of bytes that represents the bit rate, input frequency, number of multiplication ratios, and multiplication ratio
- Bit rate (2 bytes): New bit rate
One hundredth of the value (e.g. when the value is 19200 bps, it will be 192, which is H'00C0.)
- Input frequency (2 bytes): Frequency of the clock input to the boot program
This is valid to the hundredths place and represents the value in MHz multiplied by 100. (E.g. when the value is 20.00 MHz, it will be 2000, which is H'07D0.)
- Number of multiplication ratios (1 byte): The number of multiplication ratios to which the device can be set.
- Multiplication ratio 1 (1 byte) : The value of multiplication or division ratios for the main operating frequency
Multiplication ratio (1 byte): The value of the multiplication ratio (e.g. when the clock frequency is multiplied by four, the multiplication ratio will be H'04.)
Division ratio: The inverse of the division ratio, as a negative number (e.g. when the clock frequency is divided by two, the value of division ratio will be H'FE. H'FE = D'-2)
- Multiplication ratio 2 (1 byte): The value of multiplication or division ratios for the peripheral frequency
Multiplication ratio (1 byte): The value of the multiplication ratio (e.g. when the clock frequency is multiplied by four, the multiplication ratio will be H'04.)
(Division ratio: The inverse of the division ratio, as a negative number (E.g. when the clock is divided by two, the value of division ratio will be H'FE. H'FE = D'-2)
- SUM (1 byte): Checksum

Response

H'06

- Response, H'06, (1 byte): Response to selection of a new bit rate
When it is possible to set the bit rate, the response will be ACK.

Error Response

H'BF	ERROR
------	-------

- Error response, H'BF, (1 byte): Error response to selection of new bit rate

- **ERROR:** (1 byte): Error code
 - H'11: Sum checking error
 - H'24: Bit-rate selection error
The rate is not available.
 - H'25: Error in input frequency
This input frequency is not within the specified range.
 - H'26: Multiplication-ratio error
The ratio does not match an available ratio.
 - H'27: Operating frequency error
The frequency is not within the specified range.

(5) Received Data Check

The methods for checking of received data are listed below.

1. Input frequency

The received value of the input frequency is checked to ensure that it is within the range of minimum to maximum frequencies which matches the clock modes of the specified device. When the value is out of this range, an input-frequency error is generated.

2. Multiplication ratio

The received value of the multiplication ratio or division ratio is checked to ensure that it matches the clock modes of the specified device. When the value is out of this range, an multiplication-ratio error is generated.

3. Operating frequency

Operating frequency is calculated from the received value of the input frequency and the multiplication or division ratio. The input frequency is input to the LSI and the LSI is operated at the operating frequency. The expression is given below.

Operating frequency = Input frequency \times Multiplication ratio, or

Operating frequency = Input frequency \div Division ratio

The calculated operating frequency should be checked to ensure that it is within the range of minimum to maximum frequencies which are available with the clock modes of the specified device. When it is out of this range, an operating frequency error is generated.

4. Bit rate

To facilitate error checking, the value (n) of clock select (CKS) in the serial mode register (SMR), and the value (N) in the bit rate register (BRR), which are found from the peripheral operating clock frequency (ϕ) and bit rate (B), are used to calculate the error rate to ensure that it is less than

4%. If the error is more than 4%, a bit rate error is generated. The error is calculated using the following expression:

$$\text{Error (\%)} = \left\{ \left[\frac{\phi \times 10^6}{(N + 1) \times B \times 64 \times 2^{(2 \times n - 1)}} \right] - 1 \right\} \times 100$$

When the new bit rate is selectable, the rate will be set in the register after sending ACK in response. The host will send an ACK with the new bit rate for confirmation and the boot program will response with that rate.

Confirmation H'06

- Confirmation, H'06, (1 byte): Confirmation of a new bit rate

Response H'06

- Response, H'06, (1 byte): Response to confirmation of a new bit rate

The sequence of new bit-rate selection is shown in figure 20.22.

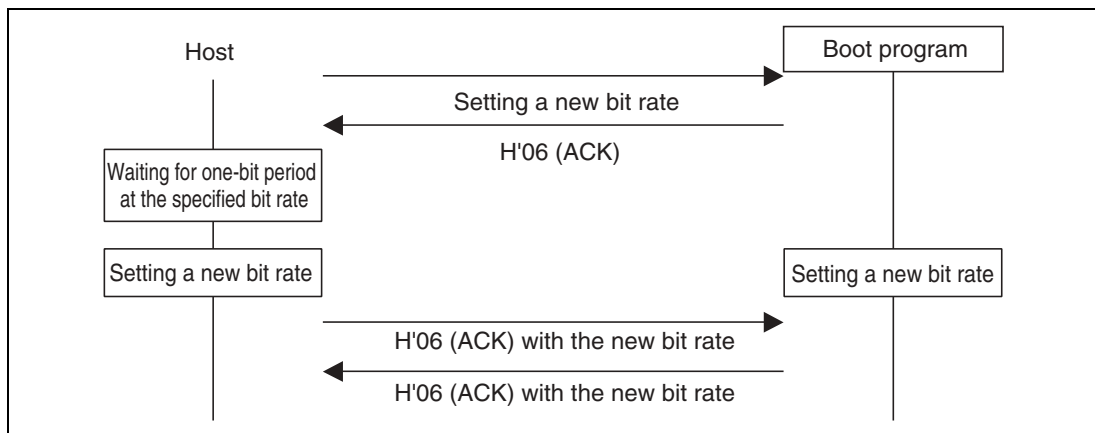

Figure 20.22 New Bit-Rate Selection Sequence

(6) Transition to Programming/Erasing State

The boot program will transfer the erasing program, and erase the user MATs and user boot MATs in that order. On completion of this erasure, ACK will be returned and will enter the programming/erasing state.

The host should select the device code, clock mode, and new bit rate with device selection, clock-mode selection, and new bit-rate selection commands, and then send the command for the transition to programming/erasing state. These procedures should be carried out before sending of the programming selection command or program data.

Command

H'40

- Command, H'40, (1 byte): Transition to programming/erasing state

Response

H'06

- Response, H'06, (1 byte): Response to transition to programming/erasing state
The boot program will send ACK when the user MAT and user boot MAT have been erased by the transferred erasing program.

Error Response

H'C0	H'51
------	------

- Error response, H'C0, (1 byte): Error response for user boot MAT blank check
- Error code, H'51, (1 byte): Erasing error
An error occurred and erasure was not completed.

(7) Command Error

A command error will occur when a command is undefined, the order of commands is incorrect, or a command is unacceptable. Issuing a clock-mode selection command before a device selection or an inquiry command after the transition to programming/erasing state command, are examples.

Error Response

H'80	H'xx
------	------

- Error response, H'80, (1 byte): Command error
- Command, H'xx, (1 byte): Received command

(8) Command Order

The order for commands in the inquiry selection state is shown below.

1. A supported device inquiry (H'20) should be made to inquire about the supported devices.
2. The device should be selected from among those described by the returned information and set with a device-selection (H'10) command.
3. A clock-mode inquiry (H'21) should be made to inquire about the supported clock modes.
4. The clock mode should be selected from among those described by the returned information and set.

5. After selection of the device and clock mode, inquiries for other required information should be made, such as the multiplication-ratio inquiry (H'22) or operating frequency inquiry (H'23), which are needed for a new bit-rate selection.
6. A new bit rate should be selected with the new bit-rate selection (H'3F) command, according to the returned information on multiplication ratios and operating frequencies.
7. After selection of the device and clock mode, the information of the user boot MAT and user MAT should be made to inquire about the user boot MAT's information inquiry (H'24), user MAT's information inquiry (H'25), erased block information inquiry (H'26), and programming unit inquiry (H'27).
8. After making inquiries and selecting a new bit rate, issue the transition to programming/erasing state command (H'40). The boot program will then enter the programming/erasing state.

(9) Programming/Erasing State

A programming selection command makes the boot program select the programming method, a 128-byte programming command makes it program the memory with data, and an erasing selection command and block erasing command make it erase the block. The programming/erasing commands are listed below.

Table 20.12 Programming/Erasing Command

Command	Command Name	Description
H'42	User boot MAT programming selection	Transfers the user boot MAT programming program
H'43	User MAT programming selection	Transfers the user MAT programming program
H'50	128-byte programming	Programs 128 bytes of data
H'48	Erasing selection	Transfers the erasing program
H'58	Block erasing	Erases a block of data
H'52	Memory read	Reads the contents of memory
H'4A	User boot MAT sum check	Checks the checksum of the user boot MAT
H'4B	User MAT sum check	Checks the checksum of the user MAT
H'4C	User boot MAT blank check	Checks whether the contents of the user boot MAT are blank
H'4D	User MAT blank check	Checks whether the contents of the user MAT are blank
H'4F	Boot program status inquiry	Inquires into the boot program's status

- Programming

Programming is executed by a programming-selection command and a 128-byte programming command.

Firstly, the host should send the programming-selection command and select the programming method and programming MATs. There are two programming selection commands, and selection is according to the area and method for programming.

1. User boot MAT programming selection
2. User MAT programming selection

After issuing the programming selection command, the host should send the 128-byte programming command. The 128-byte programming command that follows the selection command represents the data programmed according to the method specified by the selection command. When more than 128-byte data is programmed, 128-byte commands should repeatedly be executed. Sending a 128-byte programming command with H'FFFFFFFF as the address will stop the programming. On completion of programming, the boot program will wait for selection of programming or erasing.

Where the sequence of programming operations that is executed includes programming with another method or of another MAT, the procedure must be repeated from the programming selection command.

The sequence for programming-selection and 128-byte programming commands is shown in figure 20.23.

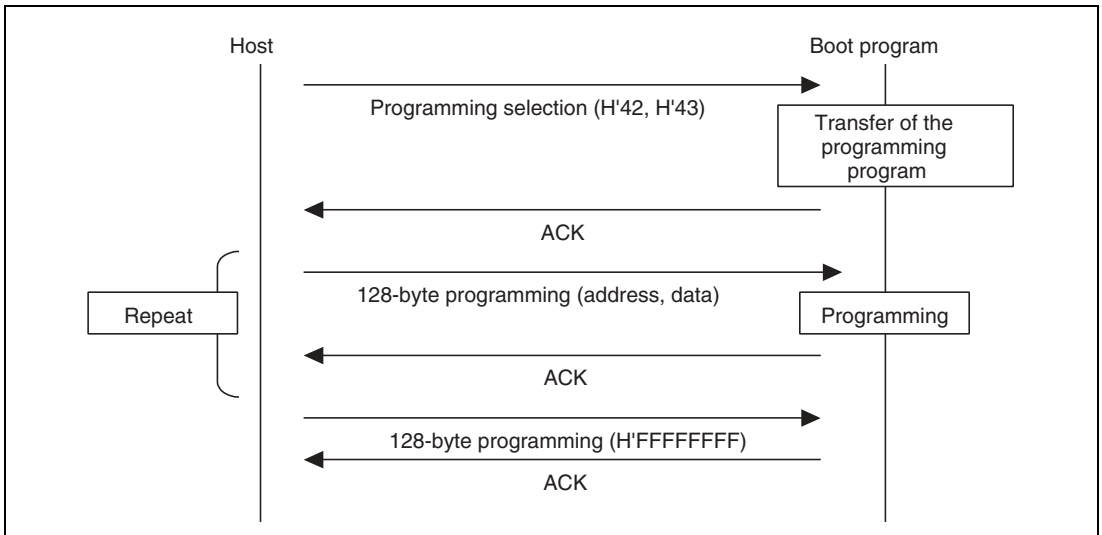

Figure 20.23 Programming Sequence

(a) User boot MAT programming selection

The boot program will transfer a programming program. The data is programmed to the user boot MATs by the transferred programming program.

Command

H'42

- Command, H'42, (1 byte): User boot MAT programming selection

Response

H'06

- Response, H'06, (1 byte): Response to user boot MAT programming selection
When the programming program has been transferred, the boot program will return ACK.

Error Response

H'C2	ERROR
------	-------

- Error response : H'C2 (1 byte): Error response to user boot MAT programming selection
- ERROR : (1 byte): Error code

H'54: Selection processing error (transfer error occurs and processing is not completed)

- User MAT programming selection

The boot program will transfer a program for programming. The data is programmed to the user MATs by the transferred program for programming.

Command

H'43

- Command, H'43, (1 byte): User MAT programming selection

Response

H'06

- Response, H'06, (1 byte): Response to user MAT programming selection
When the programming program has been transferred, the boot program will return ACK.

Error Response

H'C3	ERROR
------	-------

- Error response : H'C3 (1 byte): Error response to user MAT programming selection
- ERROR : (1 byte): Error code

H'54: Selection processing error (transfer error occurs and processing is not completed)

(b) 128-byte programming

The boot program will use the programming program transferred by the programming selection to program the user boot MATs or user MATs in response to 128-byte programming.

Command	H'50	Address					
	Data	...					
	...						
	SUM						

- Command, H'50, (1 byte): 128-byte programming
- Programming Address (4 bytes): Start address for programming
Multiple of the size specified in response to the programming unit inquiry (i.e. H'00, H'01, H'00, H'00 : H'010000)
- Programming Data (128 bytes): Data to be programmed
The size is specified in the response to the programming unit inquiry.
- SUM (1 byte): Checksum

Response

H'06

- Response, H'06, (1 byte): Response to 128-byte programming
On completion of programming, the boot program will return ACK.

Error Response

H'D0	ERROR
------	-------

- Error response, H'D0, (1 byte): Error response for 128-byte programming
- ERROR: (1 byte): Error code
 - H'11: Checksum Error
 - H'2A: Address Error
 - H'53: Programming error
 - A programming error has occurred and programming cannot be continued.

The specified address should match the unit for programming of data. For example, when the programming is in 128-byte units, the lower 8 bits of the address should be H'00 or H'80. When there are less than 128 bytes of data to be programmed, the host should fill the rest with H'FF.

Sending the 128-byte programming command with the address of H'FFFFFFFF will stop the programming operation. The boot program will interpret this as the end of the programming and wait for selection of programming or erasing.

Command

H'50	Address	SUM
------	---------	-----

- Command, H'50, (1 byte): 128-byte programming
- Programming Address (4 bytes): End code is H'FF, H'FF, H'FF, H'FF.
- SUM (1 byte): Checksum

Response

H'06

- Response, H'06, (1 byte): Response to 128-byte programming
On completion of programming, the boot program will return ACK.

Error Response

H'D0	ERROR
------	-------

- Error Response, H'D0, (1 byte): Error response for 128-byte programming

- ERROR: (1 byte): Error code
 - H'11: Checksum error
 - H'2A: Address error
 - H'53: Programming error

An error has occurred in programming and programming cannot be continued.

(10) Erasure

Erasure is performed with the erasure selection and block erasure command.

Firstly, erasure is selected by the erasure selection command and the boot program then erases the specified block. The command should be repeatedly executed if two or more blocks are to be erased. Sending a block-erasure command from the host with the block number H'FF will stop the erasure operating. On completion of erasing, the boot program will wait for selection of programming or erasing.

The sequences of issuing the erasure selection command and block-erasure command are shown in figure 20.24.

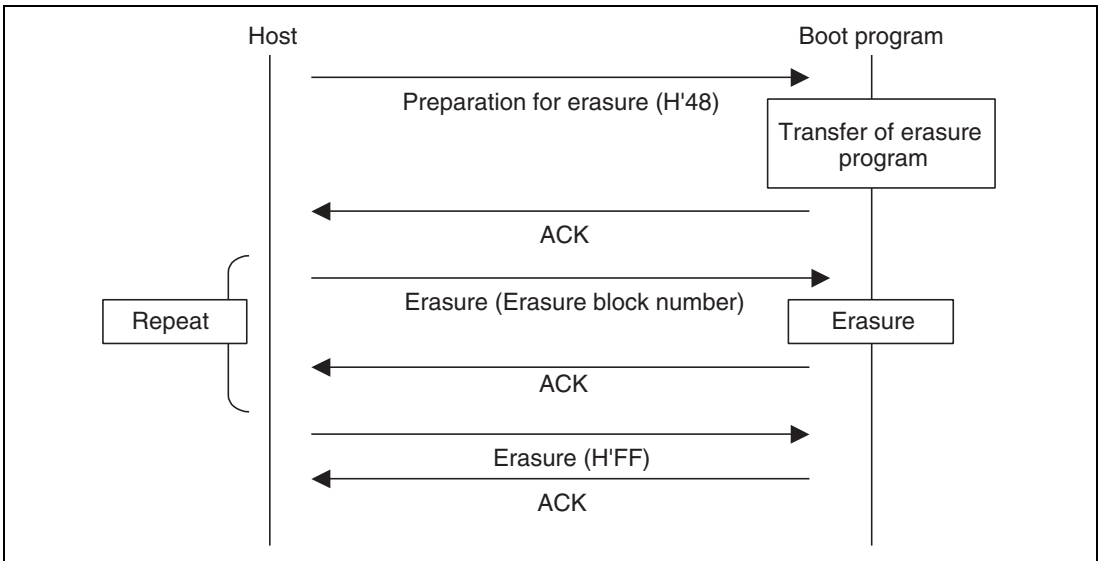

Figure 20.24 Erasure Sequence

(a) Erasure Selection

The boot program will transfer the erasure program. User MAT data is erased by the transferred erasure program.

Command

H'48

- Command, H'48, (1 byte): Erasure selection

Response

H'06

- Response, H'06, (1 byte): Response for erasure selection
After the erasure program has been transferred, the boot program will return ACK.

Error Response

H'C8	ERROR
------	-------

- Error Response, H'C8, (1 byte): Error response to erasure selection
- ERROR: (1 byte): Error code
H'54: Selection processing error (transfer error occurs and processing is not completed)

(b) Block Erasure

The boot program will erase the contents of the specified block.

Command

H'58	Size	Block number	SUM
------	------	--------------	-----

- Command, H'58, (1 byte): Erasure
- Size (1 byte): The number of bytes that represents the erasure block number
This is fixed to 1.
- Block number (1 byte): Number of the block to be erased
- SUM (1 byte): Checksum

Response

H'06

- Response, H'06, (1 byte): Response to Erasure
After erasure has been completed, the boot program will return ACK.

Error Response

H'D8	ERROR
------	-------

- Error Response, H'D8, (1 byte): Response to Erasure
- ERROR (1 byte): Error code
 - H'11: Sum check error
 - H'29: Block number error
Block number is incorrect.
 - H'51: Erasure error
An error has occurred during erasure.

On receiving block number H'FF, the boot program will stop erasure and wait for a selection command.

Command	H'58	Size	Block number	SUM
---------	------	------	--------------	-----

- Command, H'58, (1 byte): Erasure
- Size, (1 byte): The number of bytes that represents the block number
This is fixed to 1.
- Block number (1 byte): H'FF
Stop code for erasure
- SUM (1 byte): Checksum

Response	H'06
----------	------

- Response, H'06, (1 byte): Response to end of erasure (ACK)
When erasure is to be performed after the block number H'FF has been sent, the procedure should be executed from the erasure selection command.

(11) Memory read

The boot program will return the data in the specified address.

Command	H'52	Size	Area	Read address	
	Read size			SUM	

- Command: H'52 (1 byte): Memory read
- Size (1 byte): Amount of data that represents the area, read address, and read size (fixed at 9)
- Area (1 byte)
H'00: User boot MAT
H'01: User MAT
An address error occurs when the area setting is incorrect.
- Read address (4 bytes): Start address to be read from
- Read size (4 bytes): Size of data to be read
- SUM (1 byte): Checksum

Response	H'52	Read size						
	Data	...						
	SUM							

- Response: H'52 (1 byte): Response to memory read
- Read size (4 bytes): Size of data to be read
- Data (n bytes): Data for the read size from the read address
- SUM (1 byte): Checksum

Error Response	H'D2	ERROR
----------------	------	-------

- Error response: H'D2 (1 byte): Error response to memory read

- **ERROR:** (1 byte): Error code
 - H'11: Sum check error
 - H'2A: Address error
 - The read address is not in the MAT.
 - H'2B: Size error
 - The read size exceeds the MAT.

(12) User Boot MAT Sum Check

The boot program will return the byte-by-byte total of the contents of the bytes of the user boot MAT, as a 4-byte value.

Command

H'4A

- Command, H'4A, (1 byte): Sum check for user-boot MAT

Response

H'5A	Size	Checksum of user boot program	SUM
------	------	-------------------------------	-----

- Response, H'5A, (1 byte): Response to the sum check of user-boot MAT
- Size (1 byte): The number of bytes that represents the checksum
This is fixed to 4.
- Checksum of user boot program (4 bytes): Checksum of user boot MATs
The total of the data is obtained in byte units.
- SUM (1 byte): Sum check for data being transmitted

(13) User MAT Sum Check

The boot program will return the byte-by-byte total of the contents of the bytes of the user MAT.

Command

H'4B

- Command, H'4B, (1 byte): Sum check for user MAT

Response

H'5B	Size	Checksum of user program	SUM
------	------	--------------------------	-----

- Response, H'5B, (1 byte): Response to the sum check of the user MAT
- Size (1 byte): The number of bytes that represents the checksum
This is fixed to 4.
- Checksum of user boot program (4 bytes): Checksum of user MATs
The total of the data is obtained in byte units.
- SUM (1 byte): Sum check for data being transmitted

(14) User Boot MAT Blank Check

The boot program will check whether or not all user boot MATs are blank and return the result.

Command

H'4C

- Command, H'4C, (1 byte): Blank check for user boot MAT

Response

H'06

- Response, H'06, (1 byte): Response to the blank check of user boot MAT
If all user MATs are blank (H'FF), the boot program will return ACK.

Error Response

H'CC	H'52
------	------

- Error Response, H'CC, (1 byte): Response to blank check for user boot MAT
- Error Code, H'52, (1 byte): Erasure has not been completed.

(15) User MAT Blank Check

The boot program will check whether or not all user MATs are blank and return the result.

Command

H'4D

- Command, H'4D, (1 byte): Blank check for user MATs

Response

H'06

- Response, H'06, (1 byte): Response to the blank check for user boot MATs
If the contents of all user MATs are blank (H'FF), the boot program will return ACK.

Error Response

H'CD	H'52
------	------

- Error Response, H'CD, (1 byte): Error response to the blank check of user MATs.
- Error code, H'52, (1 byte): Erasure has not been completed.

(16) Boot Program State Inquiry

The boot program will return indications of its present state and error condition. This inquiry can be made in the inquiry/selection state or the programming/erasing state.

Command

H'4F

- Command, H'4F, (1 byte): Inquiry regarding boot program's state

Response

H'5F	Size	Status	ERROR	SUM
------	------	--------	-------	-----

- Response, H'5F, (1 byte): Response to boot program state inquiry
- Size (1 byte): The number of bytes. This is fixed to 2.
- Status (1 byte): State of the boot program
- ERROR (1 byte): Error status
ERROR = 0 indicates normal operation.
ERROR = 1 indicates error has occurred.
- SUM (1 byte): Sum check

Table 20.13 Status Code

Code	Description
H'11	Device Selection Wait
H'12	Clock Mode Selection Wait
H'13	Bit Rate Selection Wait
H'1F	Programming/Erasing State Transition Wait (Bit rate selection is completed)
H'31	Programming State for Erasure
H'3F	Programming/Erasing Selection Wait (Erasure is completed)
H'4F	Programming Data Receive Wait (Programming is completed)
H'5F	Erasure Block Specification Wait (Erasure is completed)

Table 20.14 Error Code

Code	Description
H'00	No Error
H'11	Sum Check Error
H'12	Program Size Error
H'21	Device Code Mismatch Error
H'22	Clock Mode Mismatch Error
H'24	Bit Rate Selection Error
H'25	Input Frequency Error
H'26	Multiplication Ratio Error
H'27	Operating Frequency Error
H'29	Block Number Error
H'2A	Address Error
H'2B	Data Length Error
H'51	Erasure Error
H'52	Erasure Incomplete Error
H'53	Programming Error
H'54	Selection Processing Error
H'80	Command Error
H'FF	Bit-Rate-Adjustment Confirmation Error

20.9 Usage Notes

1. The initial state of the product at its shipment is in the erased state. For the product whose revision of erasing is undefined, we recommend to execute automatic erasure for checking the initial state (erased state) and compensating.
2. For the PROM programmer suitable for programmer mode in this LSI and its program version, refer to the instruction manual of the socket adapter.
3. If the socket, socket adapter, or product index does not match the specifications, too much current flows and the product may be damaged.
4. If a voltage higher than the rated voltage is applied, the product may be fatally damaged. Use a PROM programmer that supports the 256 or 512-kbyte flash memory on-chip MCU device at 3.3 V. Do not set the programmer to HN28F101 or the programming voltage to 5.0 V. Use only the specified socket adapter. If other adapters are used, the product may be damaged.
5. Do not remove the chip from the PROM programmer nor input a reset signal during programming/erasing. As a high voltage is applied to the flash memory during programming/erasing, doing so may damage or destroy flash memory permanently. If reset is executed accidentally, reset must be released after the reset input period of 100 μ s which is longer than normal.
6. The flash memory is not accessible until FKEY is cleared after programming/erasing completes. If this LSI is restarted by a reset immediately after programming/erasing has finished, secure the reset period (period of $\overline{\text{RES}} = 0$) of more than 100 μ s. Though transition to the reset state or hardware standby state during programming/erasing is prohibited, if reset is executed accidentally, reset must be released after the reset input period of 100 μ s which is longer than normal.
7. At powering on or off the Vcc power supply, fix the $\overline{\text{RES}}$ pin to low and set the flash memory to hardware protection state. This power on/off timing must also be satisfied at a power-off and power-on caused by a power failure and other factors.
8. Program the area with 128-byte programming-unit blocks in on-board programming or programmer mode only once. Perform programming in the state where the programming-unit block is fully erased.
9. When the chip is to be reprogrammed with the programmer after execution of programming or erasure in on-board programming mode, it is recommend that automatic programming is performed after execution of automatic erasure.
10. To write data or programs to the flash memory, data or programs must be allocated to addresses higher than that of the external interrupt vector table (H'000040) and H'FF must be written to the areas that are reserved for the system in the exception handling vector table.
11. If data other than H'FFFFFFFF is written to the key code area (H'00003C to H'00003F) of flash memory, only H'00 can be read in programmer mode. (In this case, data is read as H'00. Rewrite is possible after erasing the data.) For reading in programmer mode, make sure to write H'FFFFFFFF to the entire key code area. If data other than H'FF is to be written to the

key code area in programmer mode, a verification error will occur unless a software countermeasure is taken for the PROM programmer and the version of its program.

12. The programming program that includes the initialization routine and the erasing program that includes the initialization routine are each 2 kbytes or less. Accordingly, when the CPU clock frequency is 33 MHz, the download for each program takes approximately 120 μ s at the maximum.
13. While an instruction in on-chip RAM is being executed, the DTC can write to the SCO bit in FCCS that is used for a download request or FMATS that is used for MAT switching. Make sure that these registers are not accidentally written to, otherwise an on-chip program may be downloaded and damage RAM or a MAT switchover may occur and the CPU get out of control. Do not use DTC to program flash related registers.
14. A programming/erasing program for flash memory used in the conventional H8S F-ZTAT microcomputer which does not support download of the on-chip program by a SCO transfer request cannot run in this LSI. Be sure to download the on-chip program to execute programming/erasing of flash memory in this LSI.
15. Unlike the conventional H8S F-ZTAT microcomputer, no countermeasures are available for a runaway by WDT during programming/erasing. Prepare countermeasures (e.g. use of the periodic timer interrupts) for WDT with taking the programming/erasing time into consideration as required.

Section 21 Boundary Scan (JTAG)

The JTAG (Joint Test Action Group) is standardized as an international standard, IEEE Standard 1149.1, and is open to the public as IEEE Standard Test Access Port and Boundary-Scan Architecture. Although the name of the function is boundary scan and the name of the group who worked on standardization is the JTAG, the JTAG is commonly used as the name of a boundary scan architecture and a serial interface to access the devices having the architecture.

This LSI has a boundary scan function (JTAG). Using this function along with other LSIs facilitates testing a printed-circuit board.

21.1 Features

- Five test pins (ETCK, ETDI, ETDO, ETMS, and $\overline{\text{ETRST}}$)
 - TAP controller
 - Six instructions
 - BYPASS mode
 - EXTEST mode
 - SAMPLE/PRELOAD mode
 - CLAMP mode
 - HIGHZ mode
 - IDCODE mode
- (These instructions are test modes corresponding to IEEE 1149.1.)

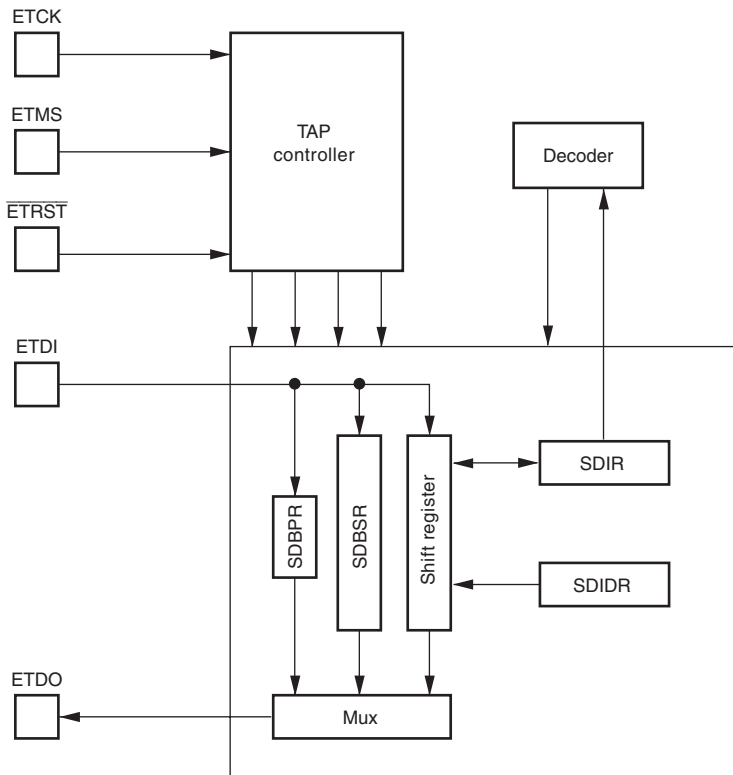

- [Legend]
- SDIR: Instruction register
 - SDBPR: Bypass register
 - SDBSR: Boundary scan register
 - SDIDR: ID code register

Figure 21.1 JTAG Block Diagram

21.2 Input/Output Pins

Table 21.1 shows the JTAG pin configuration.

Table 21.1 Pin Configuration

Pin Name	Abbreviation	I/O	Function
Test clock	ETCK	Input	Test clock input Provides an independent clock supply to the JTAG. As the clock input to the ETCK pin is supplied directly to the JTAG, a clock waveform with a duty cycle close to 50% should be input. For details, see section 25, Electrical Characteristics. If there is no input, the ETCK pin is fixed to 1 by an internal pull-up.
Test mode select	ETMS	Input	Test mode select input Sampled on the rise of the ETCK pin. The ETMS pin controls the internal state of the TAP controller. If there is no input, the ETMS pin is fixed to 1 by an internal pull-up.
Test data input	ETDI	Input	Serial data input Performs serial input of instructions and data for JTAG registers. ETDI is sampled on the rise of the ETCK pin. If there is no input, the ETDI pin is fixed to 1 by an internal pull-up.
Test data output	ETDO	Output	Serial data output Performs serial output of instructions and data from JTAG registers. Transfer is performed in synchronization with the ETCK pin. If there is no output, the ETDO pin goes to the high-impedance state.
Test reset	$\overline{\text{ETRST}}$	Input	Test reset input signal Initializes the JTAG asynchronously. If there is no input, the ETRST pin is fixed to 1 by an internal pull-up.

21.3 Register Descriptions

The JTAG has the following registers.

- Instruction register (SDIR)
- Bypass register (SDBPR)
- Boundary scan register (SDBSR)
- ID code register (SDIDR)

Instructions can be input to the instruction register (SDIR) by serial transfer from the test data input pin (ETDI). Data from SDIR can be output via the test data output pin (ETDO). The bypass register (SDBPR) is a 1-bit register to which the ETDI and ETDO pins are connected in BYPASS, CLAMP, or HIGHZ mode. The boundary scan register (SDBSR) is a 334-bit register to which the ETDI and ETDO pins are connected in SAMPLE/PRELOAD or EXTEST mode. The ID code register (SDIDR) is a 32-bit register; a fixed code can be output via the ETDO pin in IDCODE mode. All registers cannot be accessed directly by the CPU.

Table 21.2 shows the kinds of serial transfer possible with each JTAG register.

Table 21.2 JTAG Register Serial Transfer

Register	Serial Input	Serial Output
SDIR	Possible	Possible
SDBPR	Possible	Possible
SDBSR	Possible	Possible
SDIDR	Impossible	Possible

21.3.1 Instruction Register (SDIR)

SDIR is a 32-bit register. JTAG instructions can be transferred to SDIR by serial input from the ETDI pin. SDIR can be initialized when the $\overline{\text{ETRST}}$ pin is low or the TAP controller is in the Test-Logic-Reset state, but is not initialized by a reset or in standby mode.

Only 4-bit instructions can be transferred to SDIR. If an instruction exceeding 4 bits is input, the last 4 bits of the serial data will be stored in SDIR.

- H8S/2168

Bit	Bit Name	Initial Value	R/W	Description
31	TS3	1	R/W	Test Set Bits
30	TS2	1	R/W	0000: EXTEST mode
29	TS1	1	R/W	0001: Setting prohibited
28	TS0	0	R/W	0010: CLAMP mode
				0011: HIGHZ mode
				0100: SAMPLE/PRELOAD mode
				0101: Setting prohibited
				: :
				1101: Setting prohibited
				1110: IDCODE mode (Initial value)
				1111: BYPASS mode
27 to 14	—	All 0	R	Reserved These bits are always read as 0 and cannot be modified.
13	—	1	R	Reserved This bit is always read as 1 and cannot be modified.
12	—	0	R	Reserved This bit is always read as 0 and cannot be modified.
11	—	1	R	Reserved This bit is always read as 1 and cannot be modified.
10 to 1	—	All 0	R	Reserved These bits are always read as 0 and cannot be modified.
0	—	1	R	Reserved This bit is always read as 1 and cannot be modified.

- H8S/2167, H8S/2166

Bit	Bit Name	Initial Value	R/W	Description
31	TS3	1	R/W	Test Set Bits
30	TS2	1	R/W	0000: EXTEST mode
29	TS1	1	R/W	0001: Setting prohibited
28	TS0	0	R/W	0010: CLAMP mode
				0011: HIGHZ mode
				0100: SAMPLE/PRELOAD mode
				0101: Setting prohibited
				: :
				1101: Setting prohibited
				1110: IDCODE mode (Initial value)
				1111: BYPASS mode
27 to 14	—	All 0	R	Reserved These bits are always read as 0 and cannot be modified.
13	—	1	R	Reserved This bit is always read as 1 and cannot be modified.
12	—	0	R	Reserved This bit is always read as 0 and cannot be modified.
11, 10	—	All 1	R	Reserved These bits are always read as 1 and cannot be modified.
9	—	0	R	Reserved This bit is always read as 0 and cannot be modified.
8	—	1	R	Reserved This bit is always read as 1 and cannot be modified.
7 to 1	—	All 0	R	Reserved These bits are always read as 0 and cannot be modified.
0	—	1	R	Reserved This bit is always read as 1 and cannot be modified.

21.3.2 Bypass Register (SDBPR)

SDBPR is a 1-bit shift register. In BYPASS, CLAMP, or HIGHZ mode, SDBPR is connected between the ETDI and ETDO pins.

21.3.3 Boundary Scan Register (SDBSR)

SDBSR is a shift register provided on the PAD for controlling the I/O terminals of this LSI.

Using EXTEST mode or SAMPLE/PRELOAD mode, a boundary scan test conforming to the IEEE1149.1 standard can be performed.

Table 21.3 shows the relationship between the terminals of this LSI and the boundary scan register.

Table 21.3 Correspondence between Pins and Boundary Scan Register

Pin No.	Pin Name	Input/Output	Bit No.
from ETDI			
2	P45	Input	333
		Enable	332
		Output	331
3	P46	Input	330
		Enable	329
		Output	328
4	P47	Input	327
		Enable	326
		Output	325
5	P56	Input	324
		Enable	323
		Output	322
6	P57	Input	321
		Enable	320
		Output	319
9	MD1	Input	318
10	MD0	Input	317
11	NMI	Input	316
14	MD2	Input	315
15	P51	Input	314
		Enable	313
		Output	312
16	P50	Input	311
		Enable	310
		Output	309
17	P97	Input	308
		Enable	307
		Output	306
18	P96	Input	305
		Enable	304
		Output	303

Pin No.	Pin Name	Input/Output	Bit No.
19	P95	Input	302
		Enable	301
		Output	300
20	P94	Input	299
		Enable	298
		Output	297
21	P93	Input	296
		Enable	295
		Output	294
22	P92	Input	293
		Enable	292
		Output	291
23	P91	Input	290
		Enable	289
		Output	288
24	P90	Input	287
		Enable	286
		Output	285
25	PC7	Input	284
		Enable	283
		Output	282
26	PC6	Input	281
		Enable	280
		Output	279
27	PC5	Input	278
		Enable	277
		Output	276
28	PC4	Input	275
		Enable	274
		Output	273
29	PC3	Input	272
		Enable	271
		Output	270
30	PC2	Input	269
		Enable	268
		Output	267
31	PC1	Input	266
		Enable	265
		Output	264

Pin No.	Pin Name	Input/Output	Bit No.
32	PC0	Input	263
		Enable	262
		Output	261
33	PA7	Input	260
		Enable	259
		Output	258
34	PA6	Input	257
		Enable	256
		Output	255
35	PA5	Input	254
		Enable	253
		Output	252
37	PA4	Input	251
		Enable	250
		Output	249
38	PA3	Input	248
		Enable	247
		Output	246
39	PA2	Input	245
		Enable	244
		Output	243
40	PA1	Input	242
		Enable	241
		Output	240
41	PA0	Input	239
		Enable	238
		Output	237
43	P87	Input	236
		Enable	235
		Output	234
44	P86	Input	233
		Enable	232
		Output	231
45	P85	Input	230
		Enable	229
		Output	228
46	P84	Input	227
		Enable	226
		Output	225

Pin No.	Pin Name	Input/Output	Bit No.
47	P83	Input	224
		Enable	223
		Output	222
48	P82	Input	221
		Enable	220
		Output	219
49	P81	Input	218
		Enable	217
		Output	216
50	P80	Input	215
		Enable	214
		Output	213
51	PE7	Input	212
		Enable	211
		Output	210
52	PE6	Input	209
		Enable	208
		Output	207
53	PE5	Input	206
		Enable	205
		Output	204
54	PE4	Input	203
		Enable	202
		Output	201
55	PE3	Input	200
		Enable	199
		Output	198
56	PE2	Input	197
		Enable	196
		Output	195
57	PE1	Input	194
		Enable	193
		Output	192
58	PE0	Input	191
		Enable	190
		Output	189
59	PD7	Input	188
		Enable	187
		Output	186

Pin No.	Pin Name	Input/Output	Bit No.
60	PD6	Input	185
		Enable	184
		Output	183
61	PD5	Input	182
		Enable	181
		Output	180
62	PD4	Input	179
		Enable	178
		Output	177
63	PD3	Input	176
		Enable	175
		Output	174
64	PD2	Input	173
		Enable	172
		Output	171
65	PD1	Input	170
		Enable	169
		Output	168
66	PD0	Input	167
		Enable	166
		Output	165
68	P70	Input	164
69	P71	Input	163
70	P72	Input	162
71	P73	Input	161
72	P74	Input	160
73	P75	Input	159
74	P76	Input	158
75	P77	Input	157
78	P60	Input	156
		Enable	155
		Output	154
79	P61	Input	153
		Enable	152
		Output	151
80	P62	Input	150
		Enable	149
		Output	148

Pin No.	Pin Name	Input/Output	Bit No.
81	P63	Input	147
		Enable	146
		Output	145
82	P64	Input	144
		Enable	143
		Output	142
83	P65	Input	141
		Enable	140
		Output	139
84	P66	Input	138
		Enable	137
		Output	136
85	P67	Input	135
		Enable	134
		Output	133
92	PF2	Input	132
		Enable	131
		Output	130
93	PF1	Input	129
		Enable	128
		Output	127
94	PF0	Input	126
		Enable	125
		Output	124
96	P27	Input	123
		Enable	122
		Output	121
97	P26	Input	120
		Enable	119
		Output	118
98	P25	Input	117
		Enable	116
		Output	115
99	P24	Input	114
		Enable	113
		Output	112
100	P23	Input	111
		Enable	110
		Output	109

Pin No.	Pin Name	Input/Output	Bit No.
101	P22	Input	108
		Enable	107
		Output	106
102	P21	Input	105
		Enable	104
		Output	103
103	P20	Input	102
		Enable	101
		Output	100
104	P17	Input	99
		Enable	98
		Output	97
105	P16	Input	96
		Enable	95
		Output	94
106	P15	Input	93
		Enable	92
		Output	91
107	P14	Input	90
		Enable	89
		Output	88
108	P13	Input	87
		Enable	86
		Output	85
109	P12	Input	84
		Enable	83
		Output	82
110	P11	Input	81
		Enable	80
		Output	79
112	P10	Input	78
		Enable	77
		Output	76
113	PB7	Input	75
		Enable	74
		Output	73
114	PB6	Input	72
		Enable	71
		Output	70

Pin No.	Pin Name	Input/Output	Bit No.
115	PB5	Input	69
		Enable	68
		Output	67
116	PB4	Input	66
		Enable	65
		Output	64
117	PB3	Input	63
		Enable	62
		Output	61
118	PB2	Input	60
		Enable	59
		Output	58
119	PB1	Input	57
		Enable	56
		Output	55
120	PB0	Input	54
		Enable	53
		Output	52
121	P30	Input	51
		Enable	50
		Output	49
122	P31	Input	48
		Enable	47
		Output	46
123	P32	Input	45
		Enable	44
		Output	43
124	P33	Input	42
		Enable	41
		Output	40
125	P34	Input	39
		Enable	38
		Output	37
126	P35	Input	36
		Enable	35
		Output	34
127	P36	Input	33
		Enable	32
		Output	31

Pin No.	Pin Name	Input/Output	Bit No.
128	P37	Input	30
		Enable	29
		Output	28
129	P40	Input	27
		Enable	26
		Output	25
130	P41	Input	24
		Enable	23
		Output	22
131	P42	Input	21
		Enable	20
		Output	19
132	P43	Input	18
		Enable	17
		Output	16
133	P52	Input	15
		Enable	14
		Output	13
134	P53	Input	12
		Enable	11
		Output	10
135	FWE	Input	9
136	P54	Input	8
		Enable	7
		Output	6
137	P55	Input	5
		Enable	4
		Output	3
138	P44	Input	2
		Enable	1
		Output	0

to ETDO

Note: The enable signals are active-high. When an enable signal is driven high, the corresponding pin is driven with the output value.

21.3.4 ID Code Register (SDIDR)

SDIDR is a 32-bit register. In IDCODE mode, SDIDR can output H'0026200F (H8S/2168) or H'0030200F (H8S/2167 or H8S/2166), that are fixed codes, from ETDO. However, no serial data can be written to SDIDR via ETDI.

- H8S/2168

31 28	27	12	11	1	0
0000	0000 0010 0110 0010		0000 0000 111		1
Version (4 bits)	Part Number (16 bits)		Manufacture Identify (11 bits)		Fixed Code (1 bit)

- H8S/2167, H8S/2166

31 28	27	12	11	1	0
0000	0000 0011 0000 0010		0000 0000 111		1
Version (4 bits)	Part Number (16 bits)		Manufacture Identify (11 bits)		Fixed Code (1 bit)

21.4 Operation

21.4.1 TAP Controller State Transitions

Figure 21.2 shows the internal states of the TAP controller. State transitions basically conform to the IEEE1149.1 standard.

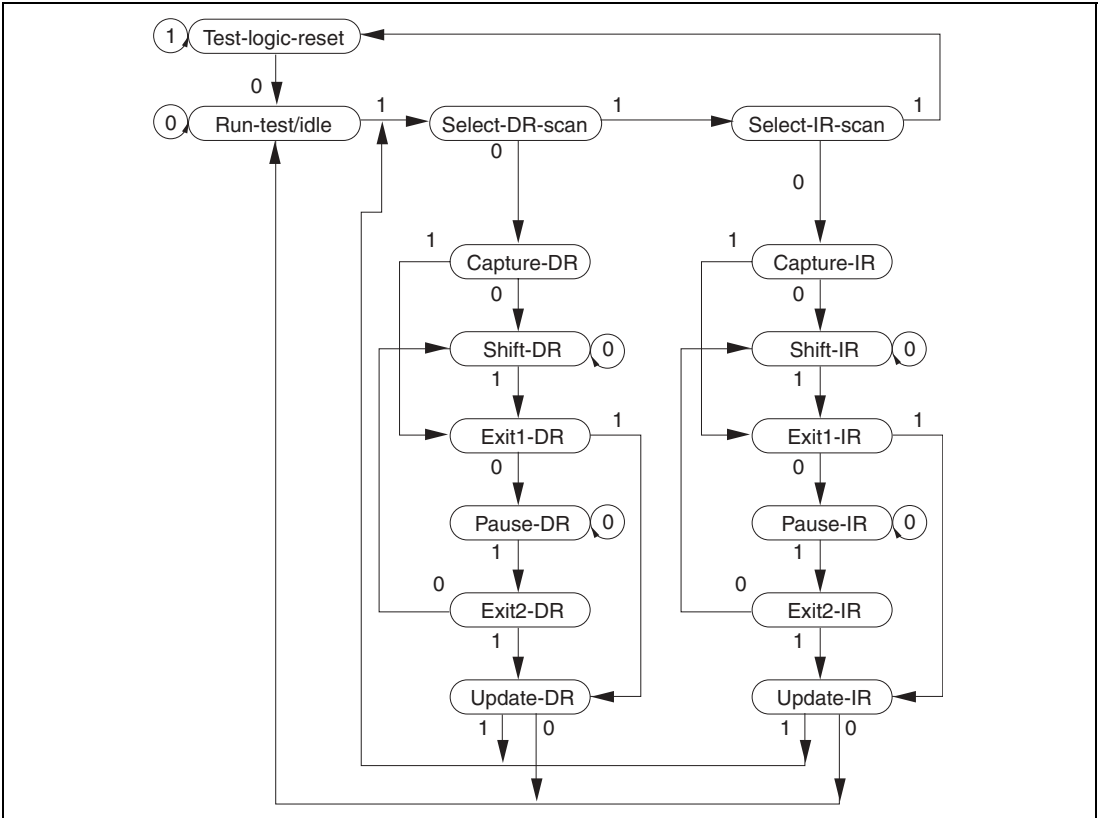

Figure 21.2 TAP Controller State Transitions

21.4.2 JTAG Reset

The JTAG can be reset in two ways.

- The JTAG is reset when the $\overline{\text{ETRST}}$ pin is held at 0.
- When $\overline{\text{ETRST}} = 1$, the JTAG can be reset by inputting at least five ETCK clock cycles while $\text{ETMS} = 1$.

21.5 Boundary Scan

The JTAG pins can be placed in the boundary scan mode stipulated by the IEEE1149.1 standard by setting a command in SDIR.

21.5.1 Supported Instructions

This LSI supports the three essential instructions defined in the IEEE1149.1 standard (BYPASS, SAMPLE/PRELOAD, and EXTEST) and optional instructions (CLAMP, HIGHZ, and IDCODE).

BYPASS: Instruction code: B'1111

The BYPASS instruction is an instruction that operates the bypass register. This instruction shortens the shift path to speed up serial data transfer involving other chips on the printed circuit board. While this instruction is being executed, the test circuit has no effect on the system circuits.

SAMPLE/PRELOAD: Instruction code: B'0100

The SAMPLE/PRELOAD instruction inputs values from this LSI internal circuitry to the boundary scan register, outputs values from the scan path, and loads data onto the scan path. When this instruction is being executed, this LSI's input pin signals are transmitted directly to the internal circuitry, and internal circuit values are directly output externally from the output pins. This LSI system circuits are not affected by execution of this instruction.

In a SAMPLE operation, a snapshot of a value to be transferred from an input pin to the internal circuitry, or a value to be transferred from the internal circuitry to an output pin, is latched into the boundary scan register and read from the scan path. Snapshot latching does not affect normal operation of this LSI.

In a PRELOAD operation, an initial value is set in the parallel output latch of the boundary scan register from the scan path prior to the EXTEST instruction. Without a PRELOAD operation, when the EXTEST instruction was executed an undefined value would be output from the output pin until completion of the initial scan sequence (transfer to the output latch) (with the EXTEST instruction, the parallel output latch value is constantly output to the output pin).

EXTEST: Instruction code: B'0000

The EXTEST instruction is provided to test external circuitry when this LSI is mounted on a printed circuit board. When this instruction is executed, output pins are used to output test data (previously set by the SAMPLE/PRELOAD instruction) from the boundary scan register to the printed circuit board, and input pins are used to latch test results into the boundary scan register from the printed circuit board. If testing is carried out by using the EXTEST instruction N times, the Nth test data is scanned in when test data (N-1) is scanned out.

Data loaded into the output pin boundary scan register in the Capture-DR state is not used for external circuit testing (it is replaced by a shift operation).

CLAMP: Instruction code: B'0010

When the CLAMP instruction is enabled, the output pin outputs the value of the boundary scan register that has been previously set by the SAMPLE/PRELOAD instruction. While the CLAMP instruction is enabled, the state of the boundary scan register maintains the previous state regardless of the state of the TAP controller.

A bypass register is connected between the ETDI and ETDO pins. The related circuit operates in the same way when the BYPASS instruction is enabled.

HIGHZ: Instruction code: B'0011

When the HIGHZ instruction is enabled, all output pins enter a high-impedance state. While the HIGHZ instruction is enabled, the state of the boundary scan register maintains the previous state regardless of the state of the TAP controller.

A bypass register is connected between the ETDI and ETDO pins. The related circuit operates in the same way when the BYPASS instruction is enabled.

IDCODE: Instruction code: B'1110

When the IDCODE instruction is enabled, the value of the ID code register is output from the ETDO pin with LSB first when the TAP controller is in the Shift-DR state. While the IDCODE instruction is being executed, the test circuit does not affect the system circuit.

When the TAP controller is in the Test-Logic-Reset state, the instruction register is initialized to the IDCODE instruction.

- Notes:
1. Boundary scan mode does not cover power-supply-related pins (VCC, VCL, VSS, AVCC, AVSS, and AVref).
 2. Boundary scan mode does not cover clock-related pins (EXTAL, XTAL, and PFSEL).
 3. Boundary scan mode does not cover reset- and standby-related pins ($\overline{\text{RES}}$, $\overline{\text{STBY}}$, and $\overline{\text{RESO}}$).
 4. Boundary scan mode does not cover JTAG-related pins (ETCK, ETDI, ETDO, ETMS, and $\overline{\text{ETRST}}$).
 5. Fix the $\overline{\text{MD2}}$ pin high.
 6. Use the $\overline{\text{STBY}}$ pin in high state.

21.6 Usage Notes

1. A reset must always be executed by driving the $\overline{\text{ETRST}}$ pin to 0, regardless of whether or not the JTAG is to be activated. The $\overline{\text{ETRST}}$ pin must be held low for 20 ETCK clock cycles. For details, see section 25, Electrical Characteristics. To activate the JTAG after a reset, drive the $\overline{\text{ETRST}}$ pin to 1 and specify the ETCK, ETMS, and ETDI pins to any value. If the JTAG is not to be activated, drive the $\overline{\text{ETRST}}$, ETCK, ETMS, and ETDI pins to 1 or the high-impedance state. These pins are internally pulled up and are noted in standby mode.
2. The following must be considered when the power-on reset signal is applied to the $\overline{\text{ETRST}}$ pin.
 - The reset signal must be applied at power-on.
 - To prevent the LSI system operation from being affected by the $\overline{\text{ETRST}}$ pin of the board tester, circuits must be separated .
 - Alternatively, to prevent the $\overline{\text{ETRST}}$ pin of the board tester from being affected by the LSI system reset, circuits must be separated.

Figure 21.3 shows a design example of the reset signal circuit wherein no reset signal interference occurs.

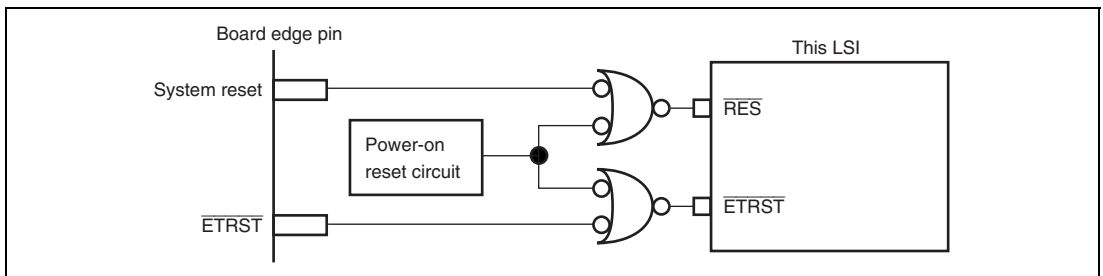

Figure 21.3 Reset Signal Circuit Without Reset Signal Interference

3. The registers are not initialized in standby mode. If the $\overline{\text{ETRST}}$ pin is set to 0 in standby mode, IDCODE mode will be entered.
4. The frequency of the ETCK pin must be lower than that of the system clock. For details, see section 25, Electrical Characteristics.
5. Data input/output in serial data transfer starts from the LSB. Figure 21.4 and 21.5 shows examples of serial data input/output.
6. When data that exceeds the number of bits of the register connected between the ETDI and ETDO pins is serially transferred, the serial data that exceeds the number of register bits and output from the ETDO pin is the same as that input from the ETDI pin.
7. If the JTAG serial transfer sequence is disrupted, the $\overline{\text{ETRST}}$ pin must be reset. Transfer should then be retried, regardless of the transfer operation.
8. If a pin with a pull-up function is sampled while its pull-up function is enabled, 1 can be detected at the corresponding input scan register. In this case, the corresponding enable scan register should be cleared to 0.

9. If a pin with an open-drain function is sampled while its open-drain function is enabled and its corresponding output scan register is 1, 0 can be detected at the corresponding enable scan register.

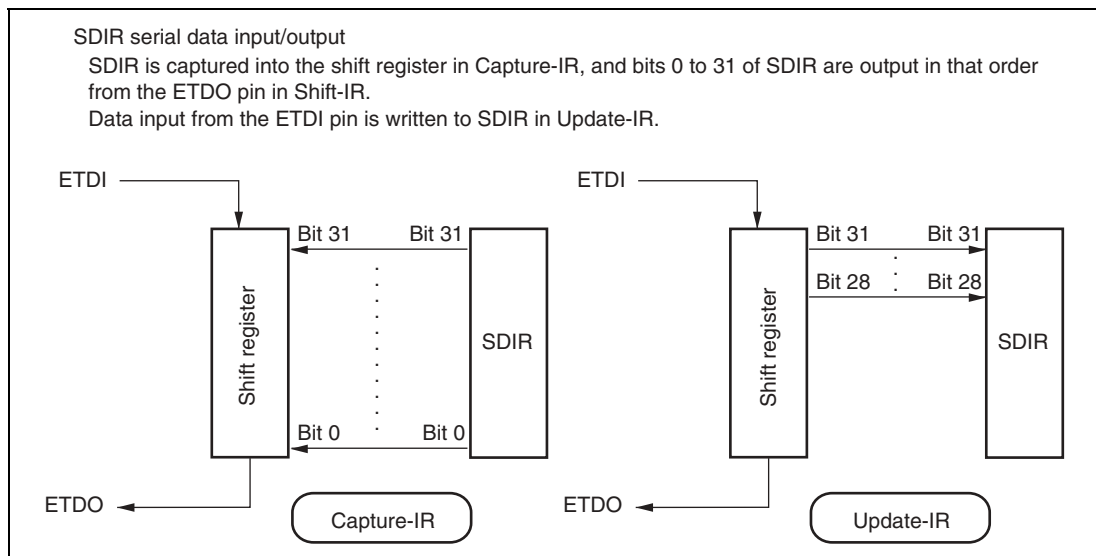

Figure 21.4 Serial Data Input/Output (1)

SDIDR serial data input/output

SDIDR is captured into the shift register in Capture-DR in IDCODE mode, and bits 0 to 31 of SDIDR are output in that order from the ETDO pin in Shift-DR.

Data input from the ETDI pin is not written to any register in Update-DR.

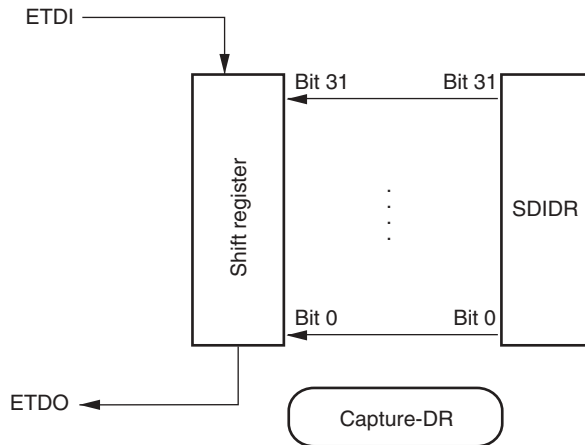

Figure 21.5 Serial Data Input/Output (2)

Section 22 Clock Pulse Generator

This LSI incorporates a clock pulse generator which generates the system clock (ϕ), internal clock, bus master clock, and subclock (ϕ SUB). The clock pulse generator consists of an oscillator, PLL multiplier circuit, system clock select circuit, medium-speed clock divider, bus master clock select circuit, subclock input circuit, and subclock waveform forming circuit. Figure 22.1 shows a block diagram of the clock pulse generator.

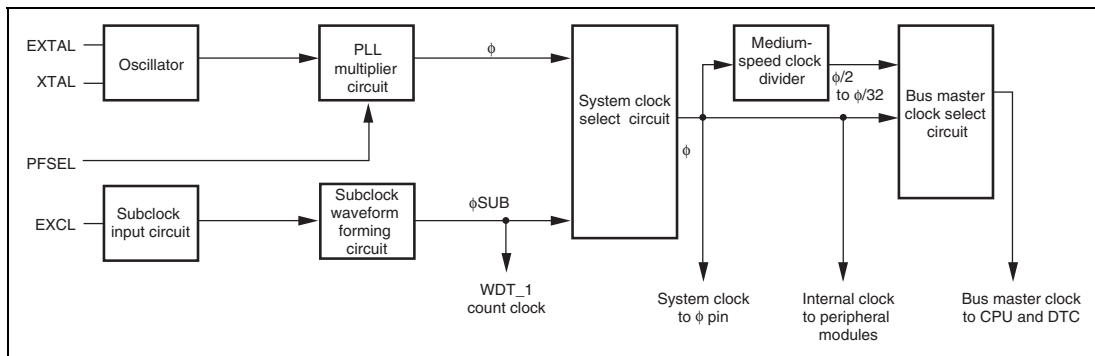

Figure 22.1 Block Diagram of Clock Pulse Generator

The bus master clock is selected as either high-speed mode or medium-speed mode by software according to the settings of the SCK2 to SCK0 bits in the standby control register. Use of the medium-speed clock ($\phi/2$ to $\phi/32$) may be limited during CPU operation and when accessing the internal memory of the CPU. The operation speed of the DTC and the external space access cycle are thus stabilized regardless of the setting of medium-speed mode. For details on the standby control register, see section 23.1.1, Standby Control Register (SBYCR).

The subclock input is controlled by software according to the EXCLE bit setting in the low power control register. For details on the low power control register, see section 23.1.2, Low-Power Control Register (LPWRCR).

22.1 Oscillator

Clock pulses can be supplied either by connecting a crystal resonator or by providing external clock input.

22.1.1 Connecting Crystal Resonator

Figure 22.2 shows a typical method of connecting a crystal resonator. An appropriate damping resistance R_d , given in table 22.1, should be used. An AT-cut parallel-resonance crystal resonator should be used.

Figure 22.3 shows the equivalent circuit of a crystal resonator. A crystal resonator having the characteristics given in table 22.2 should be used.

When PFSEL is high, the system clock (ϕ) frequency should be no more than 25 MHz and a crystal resonator with frequency identical to that of the system clock (ϕ) should be used. When PFSEL is low, a crystal resonator with $\frac{1}{4}$ times the frequency of the system clock (ϕ) should be used.

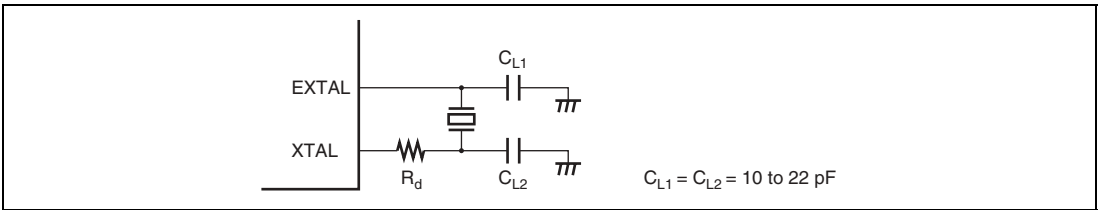

Figure 22.2 Typical Connection to Crystal Resonator

Table 22.1 Damping Resistance Values

Frequency (MHz)	5	8	10	12	16	20	25
R_d (Ω)	300	200	0	0	0	0	0

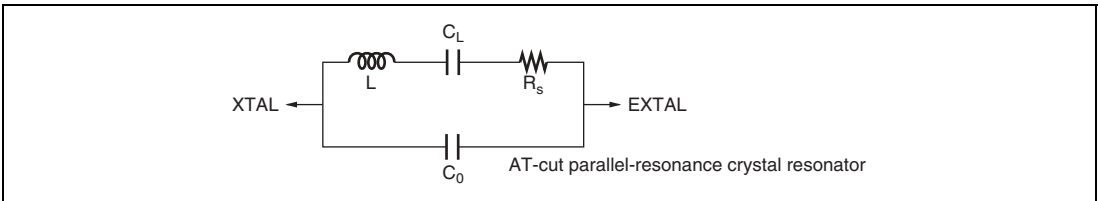

Figure 22.3 Equivalent Circuit of Crystal Resonator

Table 22.2 Crystal Resonator Parameters

Frequency(MHz)	5	8	10	12	16	20	25
R_s (max) (Ω)	100	80	70	60	50	40	30
C_0 (max) (pF)	7	7	7	7	7	7	7

22.1.2 External Clock Input Method

Figure 22.4 shows a typical method of connecting an external clock signal. To leave the XTAL pin open, incidental capacitance should be 10 pF or less.

To input an inverted clock to the XTAL pin, the external clock should be set to high in standby mode, subactive mode, subsleep mode, and watch mode. The frequency of the external clock should be the same as that of the system clock (ϕ) when PFSEL is high. When PFSEL is low, an external clock of 1/4 times the frequency of the system clock (ϕ) should be used.

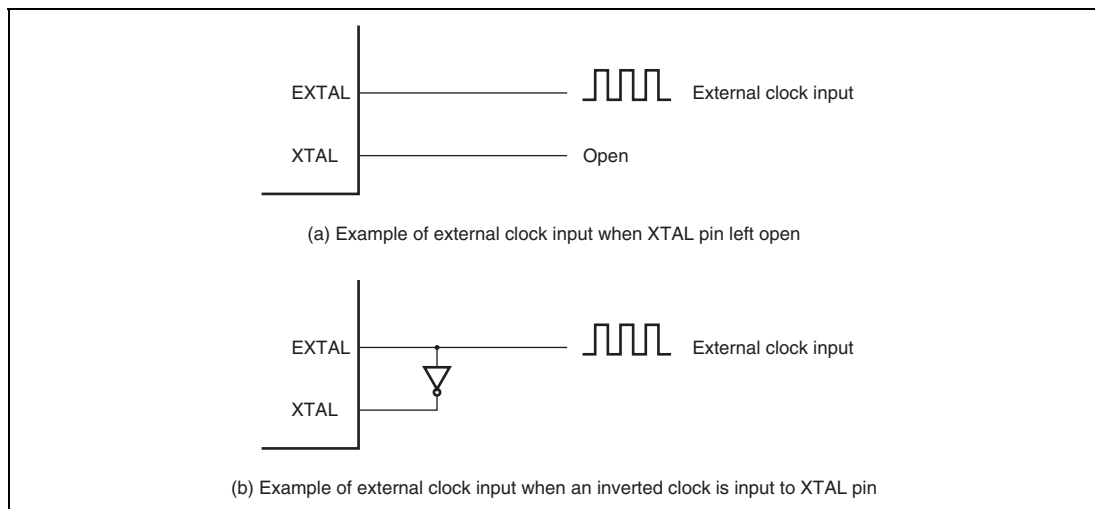

Figure 22.4 Example of External Clock Input

When a specified clock signal is input to the EXTAL pin, internal clock signal output is determined after the external clock output stabilization delay time (t_{DEXT}) has passed. As the clock signal output is not determined during the t_{DEXT} cycle, a reset signal should be set to low to hold it in reset state. For the external clock output stabilization delay time, refer to table 25.5 and figure 25.8.

22.2 PLL Multiplier Circuit

The PLL multiplier circuit generates a clock of 1 or 4 times the frequency of its input clock. The PFSEL states and corresponding multiplier values are shown in table 22.5.

Table 22.3 PFSEL and Multipliers

	Input Clock (MHz)	PFSEL	Multiplier	System Clock (MHz)
Crystal Resonator	5 to 25	1	1	5 to 25
	5 to 8.25	0	4	20 to 33
External Clock	5 to 33	1	1	5 to 33
	5 to 8.25	0	4	20 to 33

22.3 Medium-Speed Clock Divider

The medium-speed clock divider divides the system clock (ϕ), and generates $\phi/2$, $\phi/4$, $\phi/8$, $\phi/16$, and $\phi/32$ clocks.

22.4 Bus Master Clock Select Circuit

The bus master clock select circuit selects a clock to supply the bus master with either the system clock (ϕ) or medium-speed clock ($\phi/2$, $\phi/4$, $\phi/8$, $\phi/16$, or $\phi/32$) by the SCK2 to SCK0 bits in SBYCR.

22.5 Subclock Input Circuit

The subclock input circuit controls subclock input from the EXCL pin. To use the subclock, a 32.768-kHz external clock should be input from the EXCL pin. At this time, the P96DDR bit in P9DDR should be cleared to 0, and the EXCLE bit in LPWRCR should be set to 1.

When the subclock is not used, subclock input should not be enabled.

22.6 Subclock Waveform Forming Circuit

To remove noise from the subclock input at the EXCL pin, the subclock is sampled by a divided ϕ clock. The sampling frequency is set by the NESEL bit in LPWRCR.

The subclock is not sampled in subactive mode, subsleep mode, or watch mode.

22.7 Clock Select Circuit

The clock select circuit selects the system clock that is used in this LSI.

A clock generated by the oscillator, to which the EXTAL and XTAL pins are input, and multiplied by the PLL circuit is selected as a system clock when returning from high-speed mode, medium-speed mode, sleep mode, the reset state, or standby mode.

In subactive mode, subsleep mode, or watch mode, a subclock input from the EXCL pin is selected as a system clock when the EXCLE bit in LPWRCR is 1. At this time, modules such as the CPU, TMR_0, TMR_1, WDT_0, WDT_1, ports, and interrupt controller and their functions operate on the ϕ SUB. The count clock and sampling clock for each timer are divided ϕ SUB clocks.

22.8 Usage Notes

22.8.1 Note on Resonator

Since all kinds of characteristics of the resonator are closely related to the board design by the user, use the example of resonator connection in this document for only reference; be sure to use an resonator that has been sufficiently evaluated by the user. Consult with the resonator manufacturer about the resonator circuit ratings which vary depending on the stray capacitances of the resonator and installation circuit. Make sure the voltage applied to the oscillation pins do not exceed the maximum rating.

22.8.2 Notes on Board Design

When using a crystal resonator, the crystal resonator and its load capacitors should be placed as close as possible to the EXTAL and XTAL pins. Other signal lines should be routed away from the oscillation circuit to prevent inductive interference with the correct oscillation as shown in figure 22.5.

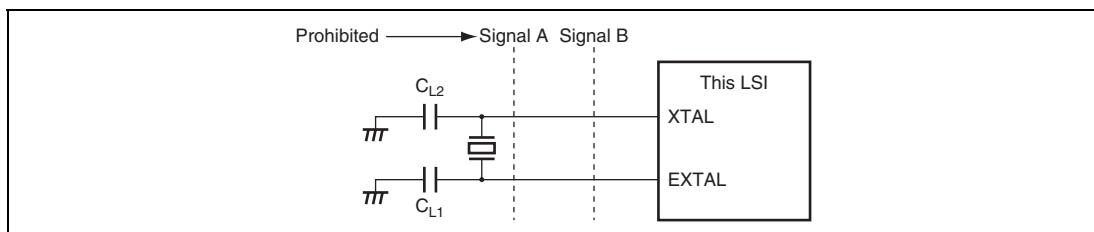

Figure 22.5 Note on Board Design of Oscillation Circuit Section

22.8.3 Note on Operation Check

This LSI may oscillate at several kHz of frequency even when a crystal resonator is not connected to the EXTAL and XTAL pins or an external clock is not input. Use this LSI after confirming that the LSI operates with appropriate frequency.

Section 23 Power-Down Modes

For operating modes after the reset state is cancelled, this LSI has not only the normal program execution state but also seven power-down modes in which power consumption is significantly reduced. In addition, there is also module stop mode in which reduced power consumption can be achieved by individually stopping on-chip peripheral modules.

- Medium-speed mode
System clock frequency for the CPU operation can be selected as $\phi/2$, $\phi/4$, $\phi/8$, $\phi/16$, or $\phi/32$.
- Subactive mode
The CPU operates based on the subclock and on-chip peripheral modules other than TMR_0, TMR_1, WDT_0, and WDT_1 stop operating.
- Sleep mode
The CPU stops but on-chip peripheral modules continue operating.
- Subsleep mode
The CPU and on-chip peripheral modules other than TMR_0, TMR_1, WDT_0, and WDT_1 stop operating.
- Watch mode
The CPU and on-chip peripheral modules other than WDT_1 stop operating.
- Software standby mode
Clock oscillation stops, and the CPU and on-chip peripheral modules stop operating.
- Hardware standby mode
Clock oscillation stops, and the CPU and on-chip peripheral modules enter reset state.
- Module stop mode
Independently of above operating modes, on-chip peripheral modules that are not used can be stopped individually.

23.1 Register Descriptions

Power-down modes are controlled by the following registers. To access SBYCR, LPWRCR, MSTPCRH, and MSTPCRL, the FLSHE bit in the serial timer control register (STCR) must be cleared to 0. For details on STCR, see section 3.2.3, Serial Timer Control Register (STCR).

- Standby control register (SBYCR)
- Low power control register (LPWRCR)
- Module stop control register H (MSTPCRH)
- Module stop control register L (MSTPCRL)
- Module stop control register A (MSTPCRA)
- Sub-chip module stop control register BH, BL (SUBMSTPBH, SUBMSTPBL)
- Sub-chip module stop control register AH, AL (SUBMSTPAH, SUBMSTPAL)

23.1.1 Standby Control Register (SBYCR)

SBYCR controls power-down modes.

Bit	Bit Name	Initial Value	R/W	Description
7	SSBY	0	R/W	<p>Software Standby</p> <p>Specifies the operating mode to be entered after executing the SLEEP instruction.</p> <p>When the SLEEP instruction is executed in high-speed mode or medium-speed mode:</p> <p>0: Shifts to sleep mode</p> <p>1: Shifts to software standby mode, subactive mode, or watch mode</p> <p>When the SLEEP instruction is executed in subactive mode:</p> <p>0: Shifts to subsleep mode</p> <p>1: Shifts to watch mode or high-speed mode</p> <p>Note that the SSBY bit is not changed even if a mode transition occurs by an interrupt.</p>

Bit	Bit Name	Initial Value	R/W	Description
6	STS2	0	R/W	Standby Timer Select 2 to 0
5	STS1	0	R/W	<p>Select the wait time for clock settling from clock oscillation start when canceling software standby mode, watch mode, or subactive mode. Select a wait time of 8 ms (oscillation settling time) or more, depending on the operating frequency.</p> <p>With an external clock, select a wait time of 500 μs (external clock output settling delay time) or more, depending on the operating frequency.</p> <p>Table 23.1 shows the relationship between the STS2 to STS0 values and wait time.</p>
4	STS0	0	R/W	
<hr/>				
3	DTSPEED	0	R/W	<p>DTC Speed</p> <p>Specifies the operating clock for the bus masters (DTC) other than the CPU in medium-speed mode.</p> <p>0: All bus masters operate based on the medium-speed clock.</p> <p>1: The DTC operates based on the system clock.</p> <p>The operating clock is changed when a DTC transfer is requested even if the CPU operates based on the medium-speed clock.</p>
<hr/>				
2	SCK2	0	R/W	System Clock Select 2 to 0
1	SCK1	0	R/W	<p>Select a clock for the bus master in high-speed mode or medium-speed mode.</p> <p>When making a transition to subactive mode or watch mode, SCK2 to SCK0 must be cleared to 0.</p> <p>000: High-speed mode (Initial value)</p> <p>001: Medium-speed clock: $\phi/2$</p> <p>010: Medium-speed clock: $\phi/4$</p> <p>011: Medium-speed clock: $\phi/8$</p> <p>100: Medium-speed clock: $\phi/16$</p> <p>101: Medium-speed clock: $\phi/32$</p> <p>11*: Must not be set.</p>
0	SCK0	0	R/W	
<hr/>				

[Legend]

*: Don't care

Table 23.1 Operating Frequency and Wait Time

STS2	STS1	STS0	Wait Time	33M Hz	25M Hz	20 MHz	10 MHz	8 MHz	6 MHz	Unit
0	0	0	8192 states	0.2	0.3	0.4	0.8	1.0	1.3	ms
0	0	1	16384 states	0.5	0.7	0.8	1.6	2.0	2.7	
0	1	0	32768 states	1.0	1.3	1.6	3.3	4.1	5.5	
0	1	1	65536 states	2.0	2.6	3.3	6.6	8.2	10.9	
1	0	0	131072 states	4.0	5.2	6.6	13.1	16.4	21.8	
1	0	1	262144 states	8.0	10.5	13.1	26.2	32.8	43.7	
1	1	0	Reserved	—	—	—	—	—	—	
1	1	1	16 states*	0.5	0.7	0.8	1.6	2.0	2.7	μs

 Recommended specification

Note: Setting prohibited.

23.1.2 Low-Power Control Register (LPWRCR)

LPWRCR controls power-down modes and signals in the multiplex bus extended mode.

Bit	Bit Name	Initial Value	R/W	Description
7	DTON	0	R/W	Direct Transfer On Flag Specifies the operating mode to be entered after executing the SLEEP instruction. When the SLEEP instruction is executed in high-speed mode or medium-speed mode: 0: Shifts to sleep mode, software standby mode, or watch mode 1: Shifts directly to subactive mode, or shifts to sleep mode or software standby mode When the SLEEP instruction is executed in subactive mode: 0: Shifts to subsleep mode or watch mode 1: Shifts directly to high-speed mode, or shifts to subsleep mode

Bit	Bit Name	Initial Value	R/W	Description
6	LSON	0	R/W	<p>Low-Speed On Flag</p> <p>Specifies the operating mode to be entered after executing the SLEEP instruction. This bit also controls whether to shift to high-speed mode or subactive mode when watch mode is cancelled.</p> <p>When the SLEEP instruction is executed in high-speed mode or medium-speed mode:</p> <p>0: Shifts to sleep mode, software standby mode, or watch mode 1: Shifts to watch mode or subactive mode</p> <p>When the SLEEP instruction is executed in subactive mode:</p> <p>0: Shifts directly to watch mode or high-speed mode 1: Shifts to subsleep mode or watch mode</p> <p>When watch mode is cancelled:</p> <p>0: Shifts to high-speed mode 1: Shifts to subactive mode</p>
5	NESEL	0	R/W	<p>Noise Elimination Sampling Frequency Select</p> <p>Selects the frequency by which the subclock (ϕSUB) input from the EXCL pin is sampled using the clock (ϕ) generated by the system clock pulse generator.</p> <p>0: Sampling using $\phi/32$ clock 1: Sampling using $\phi/4$ clock</p>
4	EXCLE	0	R/W	<p>Subclock Input Enable</p> <p>Enables/disables subclock input from the EXCL pin.</p> <p>0: Disables subclock input from the EXCL pin 1: Enables subclock input from the EXCL pin</p>
3	—	0	R/W	<p>Reserved</p> <p>The initial value should not be changed.</p>
2	PNCCS	0	R/W	<p>Address Multiplex Chip Select</p> <p>Controls the output polarity of chip select signals ($\overline{\text{CS256}}$, $\overline{\text{CPCS}}$, $\overline{\text{IOS}}$) in the address multiplex extended mode.</p> <p>0: Outputs $\overline{\text{CS256}}$, $\overline{\text{CPCS}}$, and $\overline{\text{IOS}}$ 1: Outputs CS256, CPCS, and IOS</p>
1	PNCAH	0	R/W	<p>Address Multiplex Address Hold</p> <p>Controls the output polarity of the address hold signal ($\overline{\text{AH}}$) in the address multiplex extended mode.</p> <p>0: Outputs $\overline{\text{AH}}$ 1: Outputs AH</p>

Bit	Bit Name	Initial Value	R/W	Description
0	—	0	R/W	Reserved

The initial value should not be changed.

23.1.3 Module Stop Control Registers H, L, and A (MSTPCRH, MSTPCRL, MSTPCRA)

MSTPCR specifies on-chip peripheral modules to shift to module stop mode in module units. Each module can enter module stop mode by setting the corresponding bit to 1.

- MSTPCRH

Bit	Bit Name	Initial Value	R/W	Corresponding Module
7	MSTP15	0	R/W	Reserved
The initial value should not be changed.				
6	MSTP14	0	R/W	Data transfer controller (DTC)
5	MSTP13	1	R/W	16-bit free-running timer (FRT)
4	MSTP12	1	R/W	8-bit timers (TMR_0, TMR_1)
3	MSTP11	1	R/W	8-bit PWM timer (PWM), 14-bit PWM timer (PWMX)
2	MSTP10	1	R/W	D/A converter
1	MSTP9	1	R/W	A/D converter
0	MSTP8	1	R/W	8-bit timers (TMR_X, TMR_Y)

- MSTPCRL

Bit	Bit Name	Initial Value	R/W	Corresponding Module
7	MSTP7	1	R/W	Serial communication interface 0 (SCI_0)
6	MSTP6	1	R/W	Serial communication interface 1 (SCI_1)
5	MSTP5	1	R/W	Serial communication interface 2 (SCI_2)
4	MSTP4	1	R/W	I ² C bus interface channel 0 (IIC_0)
3	MSTP3	1	R/W	I ² C bus interface channel 1 (IIC_1)
2	MSTP2	1	R/W	I ² C bus interface channel 2, 3 (IIC_2, IIC_3)
1	MSTP1	1	R/W	CRC operation circuit
0	MSTP0	1	R/W	I ² C bus interface channel 4, 5 (IIC_4, IIC_5)

- MSTPCRA

Bit	Bit Name	Initial Value	R/W	Corresponding Module
7 to 3	MSTPA7 to MSTPA3	All 0	R/W	Reserved The initial values should not be changed.
2	MSTPA2	0	R/W	14-bit PWM timer (PWMX_1)
1	MSTPA1	0	R/W	14-bit PWM timer (PWMX_0)
0	MSTPA0	0	R/W	8-bit PWM timer (PWM)

MSTPCR sets operation and stop by the combination of bits as follows:

MSTPCRH (bit 3) MSTP11	MSTPCRA (bit 2) MSTPA2	Function
0	0	14-bit PWM timer (PWMX_1) operates.
0	1	14-bit PWM timer (PWMX_1) stops.
1	0	14-bit PWM timer (PWMX_1) stops.
1	1	14-bit PWM timer (PWMX_1) stops.

MSTPCRH (bit 3) MSTP11	MSTPCRA (bit 1) MSTPA1	Function
0	0	14-bit PWM timer (PWMX_0) operates.
0	1	14-bit PWM timer (PWMX_0) stops.
1	0	14-bit PWM timer (PWMX_0) stops.
1	1	14-bit PWM timer (PWMX_0) stops.

MSTPCRH (bit 3) MSTP11	MSTPCRA (bit 0) MSTPA0	Function
0	0	8-bit PWM timer (PWM) operates.
0	1	8-bit PWM timer (PWM) stops.
1	0	8-bit PWM timer (PWM) stops.
1	1	8-bit PWM timer (PWM) stops.

Note: Bit 3 of MSTPCRH is the module stop bit of PWM, PWMX_0, and PWMX_1.

23.1.4 Sub-Chip Module Stop Control Registers BH, BL (SUBMSTPBH, SUBMSTPBL)

SUBMSTPB specifies on-chip peripheral modules to shift to module stop mode in module units. Each module can enter module stop mode by setting the corresponding bit to 1.

- SUBMSTPBH

Bit	Bit Name	Initial Value	R/W	Corresponding Module
7 to 0	SMSTPB15 to SMSTPB8	All 1	R/W	Reserved The initial values should not be changed.

- SUBMSTPBL

Bit	Bit Name	Initial Value	R/W	Corresponding Module
7 to 1	SMSTPB7 to SMSTPB1	All 1	R/W	Reserved The initial values should not be changed.
0	SMSTPB0	1	R/W	LPC interface (LPC)

23.1.5 Sub-Chip Module Stop Control Registers AH, AL (SUBMSTPAH, SUBMSTPAL)

Set the values in SUBMSTPAH and SUBMSTPAL same as in SUBMSTPBH and SUBMSTPBL.

- SUBMSTPAH

Bit	Bit Name	Initial Value	R/W	Corresponding Module
7 to 0	SMSTPA15 to SMSTPA8	All 1	W	Reserved The initial values should not be changed.

- SUBMSTPAL

Bit	Bit Name	Initial Value	R/W	Corresponding Module
7 to 1	SMSTPA7 to SMSTPA1	All 1	W	Reserved The initial values should not be changed.
0	SMSTPA0	1	W	LPC interface (LPC)

23.2 Mode Transitions and LSI States

Figure 23.1 shows the enabled mode transition diagram. The mode transition from program execution state to program halt state is performed by the SLEEP instruction. The mode transition from program halt state to program execution state is performed by an interrupt. The \overline{STBY} input causes a mode transition from any state to hardware standby mode. The \overline{RES} input causes a mode transition from a state other than hardware standby mode to the reset state. Table 23.2 shows the LSI internal states in each operating mode.

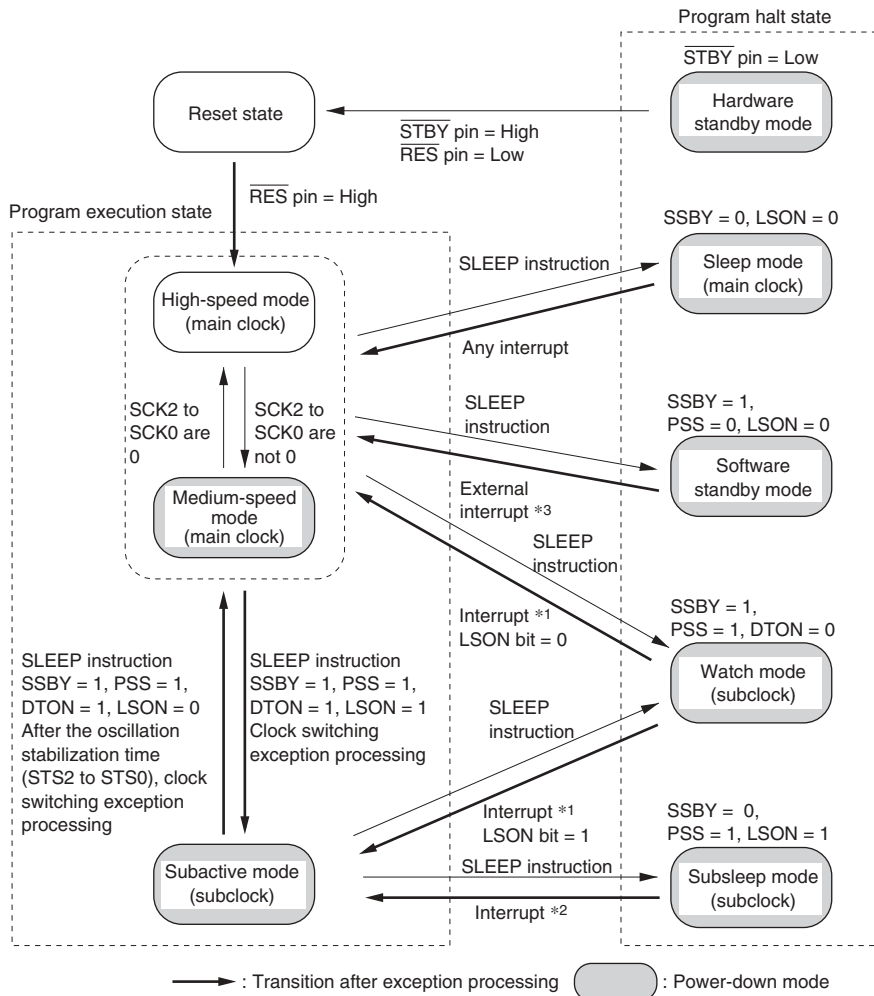

- Notes:
- When a transition is made between modes by means of an interrupt, the transition cannot be made on interrupt source generation alone. Ensure that interrupt handling is performed after accepting the interrupt request.
 - Always select high-speed mode before making a transition to watch mode or sub-active mode.
- NMI, IRQ0 to IRQ15, KIN0 to KIN15, WUE8 to WUE15, and WDT_1 interrupts
 - NMI, IRQ0 to IRQ15, KIN0 to KIN15, WUE8 to WUE15, WDT_0, WDT_1, TMR_0, and TMR_1 interrupts
 - NMI, IRQ0 to IRQ15, KIN0 to KIN15, and WUE8 to WUE15 interrupts

Figure 23.1 Mode Transition Diagram

Table 23.2 LSI Internal States in Each Mode

Function		High-Speed	Medium-Speed	Sleep	Module Stop	Watch	Sub-Active	Sub-Sleep	Software Standby	Hardware Standby
System clock pulse generator		Functioning	Functioning	Functioning	Functioning	Halted	Halted	Halted	Halted	Halted
Subclock pulse generator		Functioning	Functioning	Functioning	Functioning	Functioning	Functioning	Functioning	Halted	Halted
CPU	Instruction execution	Functioning	Functioning in medium-speed mode	Halted	Functioning	Halted	Subclock operation	Halted	Halted	Halted
	Registers			Retained		Retained		Retained	Retained	Undefined
External interrupts	NMI	Functioning	Functioning	Functioning	Functioning	Functioning	Functioning	Functioning	Functioning	Halted
	IRQ0 to IRQ15									
	KIN0 to KIN15									
	WUE8 to WUE15									
Peripheral modules	DTC	Functioning	Functioning in medium-speed mode/Functioning	Functioning	Functioning/Halted (retained)	Halted (retained)	Halted (retained)	Halted (retained)	Halted (retained)	Halted (reset)
	WDT_1		Functioning		Functioning	Subclock operation	Subclock operation	Subclock operation		
	WDT_0					Halted (retained)				
	TMR_0, TMR_1				Functioning/Halted (retained)					
	LPC						Halted (retained)	Halted (retained)		
	FRT									
	TMR_X, TMR_Y									
	IIC_0 to IIC_5									

Function	High-Speed	Medium-Speed	Sleep	Module Stop	Watch	Sub-Active	Sub-Sleep	Software Standby	Hardware Standby
Peripheral modules	CRC	Functioning	Functioning	Functioning	Functioning/Halted (retained)	Halted (retained)	Halted (retained)	Halted (retained)	Halted (reset)
	D/A converter								
	SCL_0 to SCL_2								
	PWM								
	PWMX_0, PWMX_1								
	A/D converter								
RAM		Functioning (DTC)	Functioning	Retained	Functioning	Retained	Retained	Retained	
I/O		Functioning				Functioning		High impedance	

Notes: Halted (retained) means that internal register values are retained. The internal state is operation suspended.

Halted (reset) means that internal register values and internal states are initialized.

In module stop mode, only modules for which a stop setting has been made are halted (reset or retained).

23.3 Medium-Speed Mode

The CPU makes a transition to medium-speed mode as soon as the current bus cycle ends according to the setting of the SCK2 to SCK0 bits in SBYCR. In medium-speed mode, the CPU operates on the operating clock ($\phi/2$, $\phi/4$, $\phi/8$, $\phi/16$, or $\phi/32$) specified by the SCK2 to SCK0 bits. The bus masters other than the CPU (DTC) also operate in medium-speed mode when the DTSPEED bit in SBYCR is cleared to 0. On-chip peripheral modules other than the bus masters always operate on the system clock (ϕ).

When the DTSPEED bit in SBYCR or the EXCKS bit in BCR2 is set to 1, the ϕ clock can be used as the DTC operating clock or external extended area bus cycle clock.

In medium-speed mode, a bus access is executed in the specified number of states with respect to the bus master operating clock. For example, if $\phi/4$ is selected as the operating clock, on-chip memory is accessed in 4 states, and internal I/O registers in 8 states.

By clearing all of bits SCK2 to SCK0 to 0, a transition is made to high-speed mode at the end of the current bus cycle.

If a SLEEP instruction is executed when the SSBY bit in SBYCR is cleared to 0, and the LSON bit in LPWRCR is cleared to 0, a transition is made to sleep mode. When sleep mode is cleared by an interrupt, medium-speed mode is restored. When the SLEEP instruction is executed with the SSBY bit set to 1, the LSON bit cleared to 0, and the PSS bit in TCSR (WDT_1) cleared to 0, operation shifts to software standby mode. When software standby mode is cleared by an external interrupt, medium-speed mode is restored.

When the $\overline{\text{RES}}$ pin is set low, medium-speed mode is cancelled and operation shifts to the reset state. The same applies in the case of a reset caused by overflow of the watchdog timer.

When the $\overline{\text{STBY}}$ pin is driven low, a transition is made to hardware standby mode.

Figure 23.2 shows an example of medium-speed mode timing.

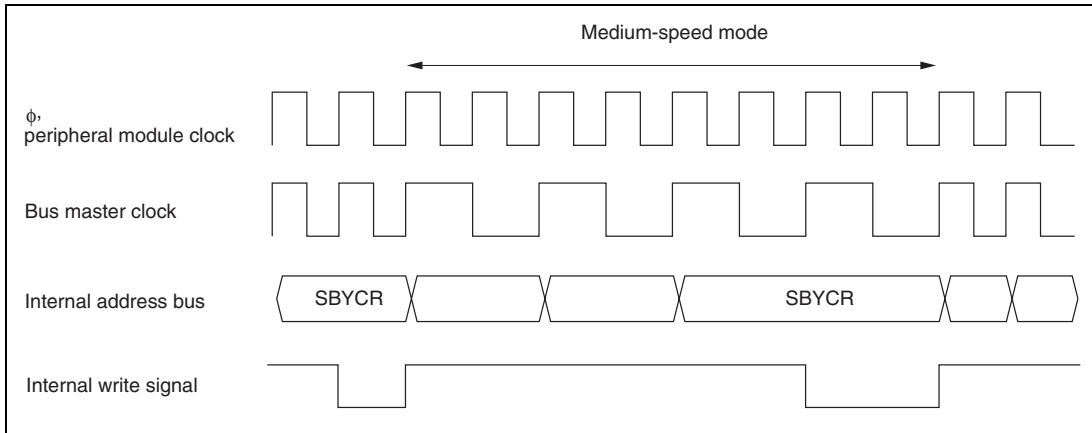

Figure 23.2 Medium-Speed Mode Timing

23.4 Sleep Mode

The CPU makes a transition to sleep mode if the SLEEP instruction is executed when the SSBY bit in SBYCR is cleared to 0 and the LSON bit in LPWRCR is cleared to 0. In sleep mode, CPU operation stops but the peripheral modules do not stop. The contents of the CPU's internal registers are retained.

Sleep mode is exited by any interrupt, the $\overline{\text{RES}}$ pin, or the $\overline{\text{STBY}}$ pin.

When an interrupt occurs, sleep mode is exited and interrupt exception handling starts. Sleep mode is not exited if the interrupt is disabled, or interrupts other than NMI are masked by the CPU.

Setting the $\overline{\text{RES}}$ pin level low cancels sleep mode and selects the reset state. After the oscillation settling time has passed, driving the $\overline{\text{RES}}$ pin high causes the CPU to start reset exception handling.

When the $\overline{\text{STBY}}$ pin level is driven low, a transition is made to hardware standby mode.

23.5 Software Standby Mode

The CPU makes a transition to software standby mode when the SLEEP instruction is executed with the SSBY bit in SBYCR set to 1, the LSON bit in LPWRCR cleared to 0, and the PSS bit in TCSR (WDT_1) cleared to 0.

In software standby mode, the CPU, on-chip peripheral modules, and clock pulse generator all stop. However, the contents of the CPU registers, on-chip RAM data, I/O ports, and the states of on-chip peripheral modules other than the PWM, PWMX, A/D converter, and part of the SCI are retained as long as the prescribed voltage is supplied.

Software standby mode is cleared by an external interrupt (NMI, IRQ0 to IRQ15, KIN0 to KIN15, or WUE8 to WUE15), the $\overline{\text{RES}}$ pin input, or $\overline{\text{STBY}}$ pin input.

When an external interrupt request signal is input, system clock oscillation starts, and after the elapse of the time set in bits STS2 to STS0 in SBYCR, software standby mode is cleared, and interrupt exception handling is started. When exiting software standby mode with an IRQ0 to IRQ15 interrupt, set the corresponding enable bit to 1. When exiting software standby mode with a KIN0 to KIN15 or WUE8 to WUE15 interrupt, enable the input. In these cases, ensure that no interrupt with a higher priority than interrupts IRQ0 to IRQ15 is generated. In the case of an IRQ0 to IRQ15 interrupt, software standby mode is not exited if the corresponding enable bit is cleared to 0 or if the interrupt has been masked by the CPU. In the case of a KIN0 to KIN15 or WUE8 to WUE15 interrupt, software standby mode is not exited if input is disabled or if the interrupt has been masked by the CPU.

When the $\overline{\text{RES}}$ pin is driven low, system clock oscillation is started. At the same time as system clock oscillation starts, the system clock is supplied to the entire LSI. Note that the $\overline{\text{RES}}$ pin must be held low until clock oscillation settles. When the $\overline{\text{RES}}$ pin goes high after clock oscillation settles, the CPU begins reset exception handling.

When the $\overline{\text{STBY}}$ pin is driven low, software standby mode is cancelled and a transition is made to hardware standby mode.

Figure 23.3 shows an example in which a transition is made to software standby mode at the falling edge of the NMI pin, and software standby mode is cleared at the rising edge of the NMI pin.

In this example, an NMI interrupt is accepted with the NMIEG bit in SYSCR cleared to 0 (falling edge specification), then the NMIEG bit is set to 1 (rising edge specification), the SSBY bit is set to 1, and a SLEEP instruction is executed, causing a transition to software standby mode.

Software standby mode is then cleared at the rising edge of the NMI pin.

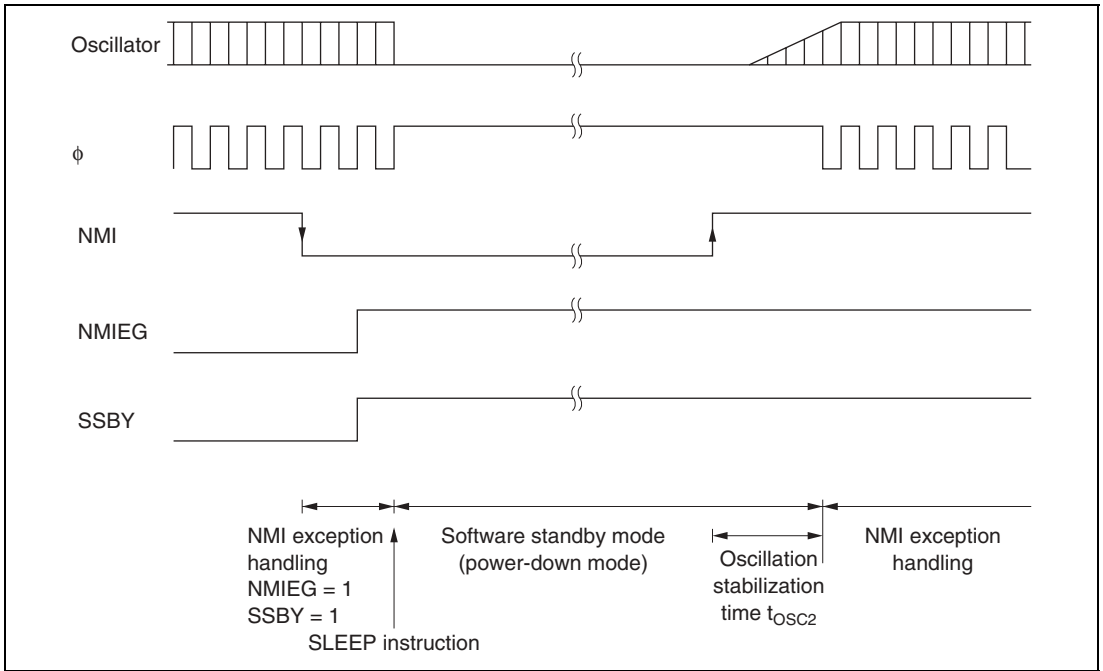

Figure 23.3 Software Standby Mode Application Example

23.6 Hardware Standby Mode

The CPU makes a transition to hardware standby mode from any mode when the $\overline{\text{STBY}}$ pin is driven low.

In hardware standby mode, all functions enter the reset state. As long as the prescribed voltage is supplied, on-chip RAM data is retained. The I/O ports are set to the high-impedance state.

In order to retain on-chip RAM data, the RAME bit in SYSCR should be cleared to 0 before driving the $\overline{\text{STBY}}$ pin low. Do not change the state of the mode pins ($\overline{\text{MD2}}$, $\overline{\text{MD1}}$, and $\overline{\text{MD0}}$) while this LSI is in hardware standby mode.

Hardware standby mode is cleared by the $\overline{\text{STBY}}$ pin input or the $\overline{\text{RES}}$ pin input.

When the $\overline{\text{STBY}}$ pin is driven high while the $\overline{\text{RES}}$ pin is low, clock oscillation is started. Ensure that the $\overline{\text{RES}}$ pin is held low until system clock oscillation settles. When the $\overline{\text{RES}}$ pin is subsequently driven high after the clock oscillation settling time has passed, reset exception handling starts.

Figure 23.4 shows an example of hardware standby mode timing.

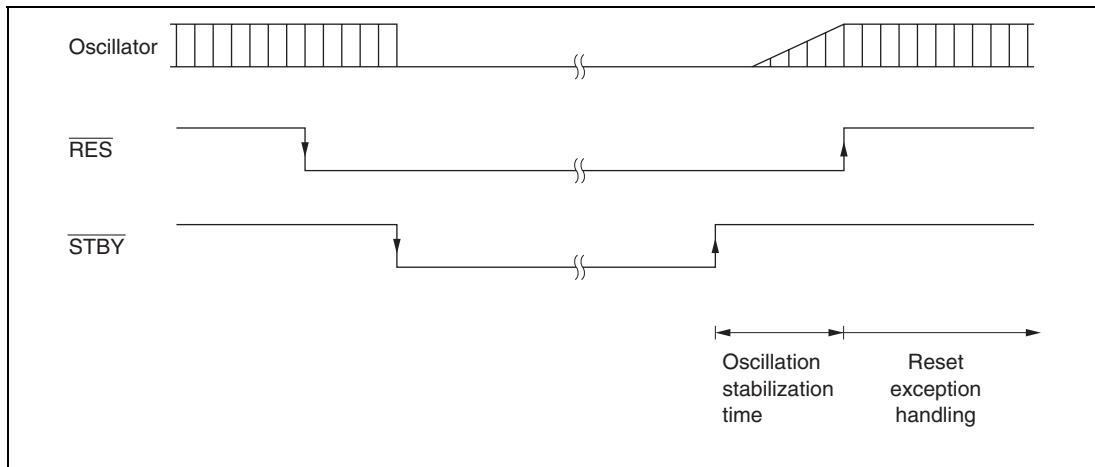

Figure 23.4 Hardware Standby Mode Timing

23.7 Watch Mode

The CPU makes a transition to watch mode when the SLEEP instruction is executed in high-speed mode or subactive mode with the SSBY bit in SBYCR set to 1, the DTON bit in LPWRCCR cleared to 0, and the PSS bit in TCSR (WDT_1) set to 1.

In watch mode, the CPU is stopped and peripheral modules other than WDT_1 are also stopped. The contents of the CPU's internal registers, several on-chip peripheral module registers, and on-chip RAM data are retained and the I/O ports retain their values before transition as long as the prescribed voltage is supplied.

Watch mode is exited by an interrupt (WOVI1, NMI, IRQ0 to IRQ15, KIN0 to KIN15, or WUE8 to WUE15), $\overline{\text{RES}}$ pin input, or $\overline{\text{STBY}}$ pin input.

When an interrupt occurs, watch mode is exited and a transition is made to high-speed mode or medium-speed mode when the LSON bit in LPWRCCR cleared to 0 or to subactive mode when the LSON bit is set to 1. When a transition is made to high-speed mode, a stable clock is supplied to the entire LSI and interrupt exception handling starts after the time set in the STS2 to STS0 bits in SBYCR has elapsed.

In the case of an IRQ0 to IRQ15 interrupt, watch mode is not exited if the corresponding enable bit has been cleared to 0 or the interrupt is masked by the CPU. In the case of a KIN0 to KIN15 or WUE8 to WUE15 interrupt, watch mode is not exited if input is disabled or the interrupt is masked by the CPU. In the case of an interrupt from the on-chip peripheral modules, watch mode is not exited if the interrupt enable register has been set to disable the reception of that interrupt or the interrupt is masked by the CPU.

When the $\overline{\text{RES}}$ pin is driven low, system clock oscillation starts. Simultaneously with the start of system clock oscillation, the system clock is supplied to the entire LSI. Note that the $\overline{\text{RES}}$ pin must be held low until clock oscillation is settled. If the $\overline{\text{RES}}$ pin is driven high after the clock oscillation settling time has passed, the CPU begins reset exception handling.

If the $\overline{\text{STBY}}$ pin is driven low, the LSI enters hardware standby mode.

23.8 Subsleep Mode

The CPU makes a transition to subsleep mode when the SLEEP instruction is executed in subactive mode with the SSBY bit in SBYCR cleared to 0, the LSON bit in LPWRCR set to 1, and the PSS bit in TCSR (WDT_1) set to 1.

In subsleep mode, the CPU is stopped. Peripheral modules other than TMR_0, TMR_1, WDT_0, and WDT_1 are also stopped. The contents of the CPU's internal registers, several on-chip peripheral module registers, and on-chip RAM data are retained and the I/O ports retain their values before transition as long as the prescribed voltage is supplied.

Subsleep mode is exited by an interrupt (interrupts by on-chip peripheral modules, NMI, IRQ0 to IRQ15, KIN0 to KIN15, or WUE8 to WUE15), the $\overline{\text{RES}}$ pin input, or the $\overline{\text{STBY}}$ pin input.

When an interrupt occurs, subsleep mode is exited and interrupt exception handling starts.

In the case of an IRQ0 to IRQ15 interrupt, subsleep mode is not exited if the corresponding enable bit has been cleared to 0 or the interrupt is masked by the CPU. In the case of a KIN0 to KIN15 or WUE8 to WUE15 interrupt, subsleep mode is not exited if input is disabled or the interrupt is masked by the CPU. In the case of an interrupt from the on-chip peripheral modules, subsleep mode is not exited if the interrupt enable register has been set to disable the reception of that interrupt or the interrupt is masked by the CPU.

When the $\overline{\text{RES}}$ pin is driven low, system clock oscillation starts. Simultaneously with the start of system clock oscillation, the system clock is supplied to the entire LSI. Note that the $\overline{\text{RES}}$ pin must be held low until clock oscillation is settled. If the $\overline{\text{RES}}$ pin is driven high after the clock oscillation settling time has passed, the CPU begins reset exception handling.

If the $\overline{\text{STBY}}$ pin is driven low, the LSI enters hardware standby mode.

23.9 Subactive Mode

The CPU makes a transition to subactive mode when the SLEEP instruction is executed in high-speed mode with the SSBY bit in SBYCR set to 1, the DTON bit and LSON bit in LPWRCCR set to 1, and the PSS bit in TCSR (WDT_1) set to 1. When an interrupt occurs in watch mode, and if the LSON bit in LPWRCCR is 1, a direct transition is made to subactive mode. Similarly, if an interrupt occurs in subsleep mode, a transition is made to subactive mode.

In subactive mode, the CPU operates at a low speed based on the subclock and sequentially executes programs. Peripheral modules other than TMR_0, TMR_1, WDT_0, and WDT_1 are also stopped.

When operating the CPU in subactive mode, the SCK2 to SCK0 bits in SBYCR must be cleared to 0.

Subactive mode is exited by the SLEEP instruction, $\overline{\text{RES}}$ pin input, or $\overline{\text{STBY}}$ pin input.

When the SLEEP instruction is executed with the SSBY bit in SBYCR set to 1, the DTON bit in LPWRCCR cleared to 0, and the PSS bit in TCSR (WDT_1) set to 1, the CPU exits subactive mode and a transition is made to watch mode. When the SLEEP instruction is executed with the SSBY bit in SBYCR cleared to 0, the LSON bit in LPWRCCR set to 1, and the PSS bit in TCSR (WDT_1) set to 1, a transition is made to subsleep mode. When the SLEEP instruction is executed with the SSBY bit in SBYCR set to 1, the DTON bit and LSON bit in LPWRCCR set to 10, and the PSS bit in TCSR (WDT_1) set to 1, a direct transition is made to high-speed mode.

For details of direct transitions, see section 23.11, Direct Transitions.

When the $\overline{\text{RES}}$ pin is driven low, system clock oscillation starts. Simultaneously with the start of system clock oscillation, the system clock is supplied to the entire LSI. Note that the $\overline{\text{RES}}$ pin must be held low until the clock oscillation is settled. If the $\overline{\text{RES}}$ pin is driven high after the clock oscillation settling time has passed, the CPU begins reset exception handling.

If the $\overline{\text{STBY}}$ pin is driven low, the LSI enters hardware standby mode.

23.10 Module Stop Mode

Module stop mode can be individually set for each on-chip peripheral module.

When the corresponding MSTP bit in MSTPCR and SUBMSTP is set to 1, module operation stops at the end of the bus cycle and a transition is made to module stop mode. In turn, when the corresponding MSTP bit is cleared to 0, module stop mode is cancelled and the module operation resumes at the end of the bus cycle. In module stop mode, the internal states of on-chip peripheral modules other than the PWM, PWMX, A/D converter, and part of the SCI are retained.

After the reset state is cancelled, all modules other than DTC are in module stop mode.

While an on-chip peripheral module is in module stop mode, read/write access to its registers is disabled.

23.11 Direct Transitions

The CPU executes programs in three modes: high-speed, medium-speed, and subactive. When a direct transition is made from high-speed mode to subactive mode, there is no interruption of program execution. A direct transition is enabled by setting the DTON bit in LPWRCR to 1 and then executing the SLEEP instruction. After a transition, direct transition exception handling starts.

The CPU makes a transition to subactive mode when the SLEEP instruction is executed in high-speed mode with the SSBY bit in SBYCR set to 1, the LSON bit and DTON bit in LPWRCR set to 11, and the PSS bit in TCSR (WDT_1) set to 1.

To make a direct transition to high-speed mode after the time set in the STS2 to STS0 bits in SBYCR has elapsed, execute the SLEEP instruction in subactive mode with the SSBY bit in SBYCR set to 1, the LSON bit and DTON bit in LPWRCR set to 01, and the PSS bit in TCSR (WDT_1) set to 1.

23.12 Usage Notes

23.12.1 I/O Port Status

The status of the I/O ports is retained in software standby mode. Therefore, when a high level is output, the current consumption is not reduced by the amount of current to support the high level output.

23.12.2 Current Consumption when Waiting for Oscillation Settling

The current consumption increases during oscillation settling.

23.12.3 DTC Module Stop Mode

If the DTC module stop mode specification and DTC bus request occur simultaneously, the bus is released to the DTC and the MSTP bit cannot be set to 1. After completing the DTC bus cycle, set the MSTP bit to 1 again.

23.12.4 Notes on Subclock Usage

When using the subclock, make a transition to power-down mode after setting the EXCLE bit in LPWRCR to 1 and loading the subclock two or more cycles. When not using the subclock, the EXCLE bit should not be set to 1.

Section 24 List of Registers

The register list gives information on the on-chip I/O register addresses, how the register bits are configured, and the register states in each operating mode. The information is given as shown below.

1. Register Addresses (address order)

- Registers are listed from the lower allocation addresses.
- The MSB-side address is indicated for 16-bit addresses.
- Registers are classified by functional modules.
- The access size is indicated.

2. Register Bits

- Bit configurations of the registers are described in the same order as the Register Addresses (address order) above.
- Reserved bits are indicated by — in the bit name column.
- The bit number in the bit-name column indicates that the whole register is allocated as a counter or for holding data.
- 16-bit registers are indicated from the bit on the MSB side.

3. Register States in Each Operating Mode

- Register states are described in the same order as the Register Addresses (address order) above.
- The register states described here are for the basic operating modes. If there is a specific reset for an on-chip peripheral module, refer to the section on that on-chip peripheral module.

24.1 Register Addresses (Address Order)

The data bus width indicates the numbers of bits by which the register is accessed.

The number of access states indicates the number of states based on the specified reference clock.

Note: Access to undefined or reserved addresses is prohibited. Since operation or continued operation is not guaranteed when these registers are accessed, do not attempt such access.

Register Name	Abbreviation	Number of Bits	Address	Module	Data Bus Width	Number of Access States
Host interface control register_4	HICR4	8	H'FE00	LPC	16	2
BT status register_0	BTSR0	8	H'FE02	LPC	16	2
BT status register_1	BTSR1	8	H'FE03	LPC	16	2
BT control status register_0	BTCSR0	8	H'FE04	LPC	16	2
BT control status register_1	BTCSR1	8	H'FE05	LPC	16	2
BT control register	BTCCR	8	H'FE06	LPC	16	2
BT interrupt mask register 0	BTIMSR	8	H'FE07	LPC	16	2
SMIC flag register	SMICFLG	8	H'FE08	LPC	16	2
SMIC control status register 1	SMICCSR	8	H'FE0A	LPC	16	2
SMIC data register	SMICDTR	8	H'FE0B	LPC	16	2
SMIC interrupt register_0	SMICIR0	8	H'FE0C	LPC	16	2
SMIC interrupt register_1	SMICIR1	8	H'FE0E	LPC	16	2
Two-way data register 0MW	TWR0MW	8	H'FE10	LPC	16	2
Two-way data register 0SW	TWR0SW	8	H'FE10	LPC	16	2
Two-way data register 1	TWR1	8	H'FE11	LPC	16	2
Two-way data register 2	TWR2	8	H'FE12	LPC	16	2
Two-way data register 3	TWR3	8	H'FE13	LPC	16	2
Two-way data register 4	TWR4	8	H'FE14	LPC	16	2
Two-way data register 5	TWR5	8	H'FE15	LPC	16	2
Two-way data register 6	TWR6	8	H'FE16	LPC	16	2
Two-way data register 7	TWR7	8	H'FE17	LPC	16	2
Two-way data register 8	TWR8	8	H'FE18	LPC	16	2
Two-way data register 9	TWR9	8	H'FE19	LPC	16	2
Two-way data register 10	TWR10	8	H'FE1A	LPC	16	2
Two-way data register 11	TWR11	8	H'FE1B	LPC	16	2
Two-way data register 12	TWR12	8	H'FE1C	LPC	16	2
Two-way data register 13	TWR13	8	H'FE1D	LPC	16	2
Two-way data register 14	TWR14	8	H'FE1E	LPC	16	2
Two-way data register 15	TWR15	8	H'FE1F	LPC	16	2

Register Name	Abbreviation	Number of Bits	Address	Module	Data Bus Width	Number of Access States
Input data register 3	IDR3	8	H'FE20	LPC	16	2
Output data register 3	ODR3	8	H'FE21	LPC	16	2
Status register 3	STR3	8	H'FE22	LPC	16	2
LPC channel 3 address register H	LADR3H	8	H'FE24	LPC	16	2
LPC channel 3 address register L	LADR3L	8	H'FE25	LPC	16	2
SERIRQ control register 0	SIRQCR0	8	H'FE26	LPC	16	2
SERIRQ control register 1	SIRQCR1	8	H'FE27	LPC	16	2
Input data register 1	IDR1	8	H'FE28	LPC	16	2
Output data register 1	ODR1	8	H'FE29	LPC	16	2
Status register 1	STR1	8	H'FE2A	LPC	16	2
Input data register 2	IDR2	8	H'FE2C	LPC	16	2
Output data register 2	ODR2	8	H'FE2D	LPC	16	2
Status register 2	STR2	8	H'FE2E	LPC	16	2
Host interface select register	HISEL	8	H'FE2F	LPC	16	2
Host interface control register 0	HICR0	8	H'FE30	LPC	16	2
Host interface control register 1	HICR1	8	H'FE31	LPC	16	2
Host interface control register 2	HICR2	8	H'FE32	LPC	16	2
Host interface control register 3	HICR3	8	H'FE33	LPC	16	2
SERIRQ control register 2	SIRQCR2	8	H'FE34	LPC	16	2
BT data buffer	BTDR	8	H'FE35	LPC	16	2
BT FIFO enable size register 0	BTFVSR0	8	H'FE36	LPC	16	2
BT FIFO enable size register 1	BTFVSR1	8	H'FE37	LPC	16	2
LPC channel 1, 2 address register H	LADR12H	8	H'FE38	LPC	16	2
LPC channel 1, 2 address register L	LADR12L	8	H'FE39	LPC	16	2

Register Name	Abbreviation	Number of Bits	Address	Module	Data Bus Width	Number of Access States
Sub-chip module stop control register AH	SUBMSTPAH	8	H'FE3C	SYSTEM	8	2
Sub-chip module stop control register AL	SUBMSTPAL	8	H'FE3D	SYSTEM	8	2
Sub-chip module stop control register BH	SUBMSTPBH	8	H'FE3E	SYSTEM	8	2
Sub-chip module stop control register BL	SUBMSTPBL	8	H'FE3F	SYSTEM	8	2
Event count status register	ECS	16	H'FE40	EVC	16	2
Event count control register	ECCR	8	H'FE42	EVC	8	2
Module stop control register A	MSTPCRA	8	H'FE43	SYSTEM	8	2
Noise canceler enable register	P6NCE	8	H'FE44	PORT	8	2
Noise canceler decision control register	P6NCMC	8	H'FE45	PORT	8	2
Noise canceler cycle setting register	P6NCCS	8	H'FE46	PORT	8	2
Port E output data register	PEODR	8	H'FE48	PORT	8	2
Port F output data register	PFODR	8	H'FE49	PORT	8	2
Port E input data register	PEPIN	8	H'FE4A (Read)	PORT	8	2
Port E data direction register	PEDDR	8	H'FE4A (Write)	PORT	8	2
Port F input data register	PFPIN	8	H'FE4B (Read)	PORT	8	2
Port F data direction register	PFDDR	8	H'FE4B (Write)	PORT	8	2
Port C output data register	PCODR	8	H'FE4C	PORT	8	2
Port D output data register	PDODR	8	H'FE4D	PORT	8	2
Port C input data register	PCPIN	8	H'FE4E (Read)	PORT	8	2
Port C data direction register	PCDDR	8	H'FE4E (Write)	PORT	8	2
Port D input data register	PDPIN	8	H'FE4F (Read)	PORT	8	2

Register Name	Abbreviation	Number of Bits	Address	Module	Data Bus Width	Number of Access States
Port D data direction register	PDDDR	8	H'FE4F (Write)	PORT	8	2
Flash code control status register	FCCS	8	H'FE88	FLASH	8	2
Flash program code select register	FPCS	8	H'FE89	FLASH	8	2
Flash erase code select register	FECS	8	H'FE8A	FLASH	8	2
Flash key code register	FKEY	8	H'FE8C	FLASH	8	2
Flash MAT select register	FMATS	8	H'FE8D	FLASH	8	2
Flash transfer destination address register	FTDAR	8	H'FE8E	FLASH	8	2
I ² C bus control register_4	ICCR_4	8	H'FEB0	IIC_4	8	2
I ² C bus status register_4	ICSR_4	8	H'FEB1	IIC_4	8	2
I ² C bus data register_4	ICDR_4	8	H'FEB2	IIC_4	8	2
Second slave address register_4	SARX_4	8	H'FEB2	IIC_4	8	2
I ² C bus mode register_4	ICMR_4	8	H'FEB3	IIC_4	8	2
Slave address register_4	SAR_4	8	H'FEB3	IIC_4	8	2
I ² C bus control register_5	ICCR_5	8	H'FEB4	IIC_5	8	2
I ² C bus status register_5	ICSR_5	8	H'FEB5	IIC_5	8	2
I ² C bus data register_5	ICDR_5	8	H'FEB6	IIC_5	8	2
Second slave address register_5	SARX_5	8	H'FEB6	IIC_5	8	2
I ² C bus mode register_5	ICMR_5	8	H'FEB7	IIC_5	8	2
Slave address register_5	SAR_5	8	H'FEB7	IIC_5	8	2
I ² C bus control register_3	ICCR_3	8	H'FEC0	IIC_3	8	2
I ² C bus status register_3	ICSR_3	8	H'FEC1	IIC_3	8	2
I ² C bus data register_3	ICDR_3	8	H'FEC2	IIC_3	8	2
Second slave address register_3	SARX_3	8	H'FEC2	IIC_3	8	2
I ² C bus mode register_3	ICMR_3	8	H'FEC3	IIC_3	8	2
Slave address register_3	SAR_3	8	H'FEC3	IIC_3	8	2
I ² C bus control register_2	ICCR_2	8	H'FEC8	IIC_2	8	2
I ² C bus status register_2	ICSR_2	8	H'FEC9	IIC_2	8	2
I ² C bus data register_2	ICDR_2	8	H'FECA	IIC_2	8	2

Register Name	Abbreviation	Number of Bits	Address	Module	Data Bus Width	Number of Access States
Second slave address register_2	SARX_2	8	H'FECA	IIC_2	8	2
I ² C bus mode register_2	ICMR_2	8	H'FECB	IIC_2	8	2
Slave address register_2	SAR_2	8	H'FECB	IIC_2	8	2
PWMX (D/A) data register A_1	DADRA_1	16	H'FECC	PWMX_1	8	4
PWMX (D/A) control register_1	DACR_1	8	H'FECC	PWMX_1	8	2
PWMX (D/A) data register B_1	DADRB_1	16	H'FECE	PWMX_1	8	4
PWMX (D/A) counter_1	DACNT_1	16	H'FECE	PWMX_1	8	4
Serial extended mode register_0	SEMR_0	8	H'FED0	SCI_0	8	2
Serial extended mode register_2	SEMR_2	8	H'FED2	SCI_2	8	2
CRC control register	CRCCR	8	H'FED4	CRC	16	2
CRC data input register	CRCDIR	8	H'FED5	CRC	16	2
CRC data output register	CRCDOR	16	H'FED6	CRC	16	2
I ² C bus control extended register_0	ICXR_0	8	H'FED8	IIC_0	8	2
I ² C bus control extended register_1	ICXR_1	8	H'FED9	IIC_1	8	2
I ² C SMBus control register	ICSMBCR	8	H'FEDB	IIC	8	2
I ² C bus control extended register_2	ICXR_2	8	H'FEDC	IIC_2	8	2
I ² C bus control extended register_3	ICXR_3	8	H'FEDD	IIC_3	8	2
I ² C bus transfer select register	IICX3	8	H'FEDF	IIC	8	2
I ² C bus control extended register_4	ICXR_4	8	H'FEE0	IIC_4	8	2
I ² C bus control extended register_5	ICXR_5	8	H'FEE1	IIC_5	8	2
Keyboard comparator control register	KBCOMP	8	H'FEE4	EVC	8	2
Serial interface control register	SCICR	8	H'FEE5	SCI_1	8	2
Interrupt control register D	ICRD	8	H'FEE7	INT	8	2
Interrupt control register A	ICRA	8	H'FEE8	INT	8	2
Interrupt control register B	ICRB	8	H'FEE9	INT	8	2
Interrupt control register C	ICRC	8	H'FEEA	INT	8	2
IRQ status register	ISR	8	H'FEEB	INT	8	2
IRQ sense control register H	ISCRH	8	H'FEEC	INT	8	2
IRQ sense control register L	ISCR_L	8	H'FEED	INT	8	2

Register Name	Abbreviation	Number of Bits	Address	Module	Data Bus Width	Number of Access States
DTC enable register A	DTCERA	8	H'FEEE	DTD	8	2
DTC enable register B	DTCERB	8	H'FEFF	DTC	8	2
DTC enable register C	DTCERC	8	H'FEF0	DTC	8	2
DTC enable register D	DTCERD	8	H'FEF1	DTC	8	2
DTC enable register E	DTCERE	8	H'FEF2	DTC	8	2
DTC vector register	DTVECR	8	H'FEF3	DTC	8	2
Address break control register	ABRKCR	8	H'FEF4	INT	8	2
Break address register A	BARA	8	H'FEF5	INT	8	2
Break address register B	BARB	8	H'FEF6	INT	8	2
Break address register C	BARC	8	H'FEF7	INT	8	2
IRQ enable register 16	IER16	8	H'FEF8	INT	8	2
IRQ status register 16	ISR16	8	H'FEF9	INT	8	2
IRQ sense control register 16H	ISCR16H	8	H'FEEA	INT	8	2
IRQ sense control register 16L	ISCR16L	8	H'FEFB	INT	8	2
IRQ sense port select register 16	ISSR16	8	H'FEFC	PORT	8	2
IRQ sense port select register	ISSR	8	H'FEFD	PORT	8	2
Port control register 0	PTCNT0	8	H'FEFE	PORT	8	2
Bus control register 2	BCR2	8	H'FF80	BSC	8	2
Wait state control register 2	WSCR2	8	H'FF81	BSC	8	2
Peripheral clock select register	PCSR	8	H'FF82	PWM	8	2
System control register 2	SYSCR2	8	H'FF83	SYSTEM	8	2
Standby control register	SBYCR	8	H'FF84	SYSTEM	8	2
Low power control register	LPWRCR	8	H'FF85	SYSTEM	8	2
Module stop control register H	MSTPCRH	8	H'FF86	SYSTEM	8	2
Module stop control register L	MSTPCRL	8	H'FF87	SYSTEM	8	2
Serial mode register_1	SMR_1	8	H'FF88	SCI_1	8	2
I ² C bus control register_1	ICCR_1	8	H'FF88	IIC_1	8	2
Bit rate register_1	BRR_1	8	H'FF89	SCI_1	8	2
I ² C bus status register_1	ICSR_1	8	H'FF89	IIC_1	8	2

Register Name	Abbreviation	Number of Bits	Address	Module	Data Bus Width	Number of Access States
Serial control register_1	SCR_1	8	H'FF8A	SCI_1	8	2
Transmit data register_1	TDR_1	8	H'FF8B	SCI_1	8	2
Serial status register_1	SSR_1	8	H'FF8C	SCI_1	8	2
Receive data register_1	RDR_1	8	H'FF8D	SCI_1	8	2
Smart card mode register_1	SCMR_1	8	H'FF8E	SCI_1	8	2
I ² C bus data register_1	ICDR_1	8	H'FF8E	IIC_1	8	2
Second slave address register_1	SARX_1	8	H'FF8E	IIC_1	8	2
I ² C bus mode register_1	ICMR_1	8	H'FF8F	IIC_1	8	2
Slave address register_1	SAR_1	8	H'FF8F	IIC_1	8	2
Timer interrupt enable register	TIER	8	H'FF90	FRT	8	2
Timer control/status register	TCSR	8	H'FF91	FRT	8	2
Free-running counter	FRC	16	H'FF92	FRT	16	2
Output Compare register A	OCRA	16	H'FF94	FRT	16	2
Output Compare register B	OCRB	16	H'FF94	FRT	16	2
Timer control register	TCR	8	H'FF96	FRT	16	2
Timer output compare control register	TOCR	8	H'FF97	FRT	16	2
Input capture register A	ICRA	16	H'FF98	FRT	16	2
Output Compare register AR	OCRAR	16	H'FF98	FRT	16	2
Input capture register B	ICRB	16	H'FF9A	FRT	16	2
Output Compare register AF	OCRAF	16	H'FF9A	FRT	16	2
Input capture register C	ICRC	16	H'FF9C	FRT	16	2
Output compare register DM	OCRDM	16	H'FF9C	FRT	16	2
Input capture register D	ICRD	16	H'FF9E	FRT	16	2
Serial mode register_2	SMR_2	8	H'FFA0	SCI_2	8	2
PWMX (D/A) control register_0	DACR_0	8	H'FFA0	PWMX_0	8	2
PWMX (D/A) data register A_0	DADRA_0	16	H'FFA0	PWMX_0	8	4
Bit rate register_2	BRR_2	8	H'FFA1	SCI_2	8	2
Serial control register_2	SCR_2	8	H'FFA2	SCI_2	8	2
Transmit data register_2	TDR_2	8	H'FFA3	SCI_2	8	2

Register Name	Abbreviation	Number of Bits	Address	Module	Data Bus Width	Number of Access States
Serial status register_2	SSR_2	8	H'FFA4	SCI_2	8	2
Receive data register_2	RDR_2	8	H'FFA5	SCI_2	8	2
Smart card mode register_2	SCMR_2	8	H'FFA6	SCI_2	8	2
PWMX (D/A) counter_0	DACNT_0	16	H'FFA6	PWMX_0	8	4
PWMX (D/A) data register B_0	DADRB_0	16	H'FFA6	PWMX_0	8	4
Timer control/status register_0	TCSR_0	8	H'FFA8 (read)	WDT_0	16	2
Timer control/status register_0	TCSR_0	16	H'FFA8 (write)	WDT_0	16	2
Timer counter_0	TCNT_0	8	H'FFA9 (read)	WDT_0	16	2
Timer counter_0	TCNT_0	16	H'FFA8 (write)	WDT_0	16	2
Port A output data register	PAODR	8	H'FFAA	PORT	8	2
Port A input data register	PAPIN	8	H'FFAB (read)	PORT	8	2
Port A data direction register	PADDR	8	H'FFAB (write)	PORT	8	2
Port 1 pull-up MOS control register	P1PCR	8	H'FFAC	PORT	8	2
Port 2 pull-up MOS control register	P2PCR	8	H'FFAD	PORT	8	2
Port 3 pull-up MOS control register	P3PCR	8	H'FFAE	PORT	8	2
Port 1 data direction register	P1DDR	8	H'FFB0	PORT	8	2
Port 2 data direction register	P2DDR	8	H'FFB1	PORT	8	2
Port 1 data register	P1DR	8	H'FFB2	PORT	8	2
Port 2 data register	P2DR	8	H'FFB3	PORT	8	2
Port 3 data direction register	P3DDR	8	H'FFB4	PORT	8	2
Port 4 data direction register	P4DDR	8	H'FFB5	PORT	8	2
Port 3 data register	P3DR	8	H'FFB6	PORT	8	2
Port 4 data register	P4DR	8	H'FFB7	PORT	8	2
Port 5 data direction register	P5DDR	8	H'FFB8	PORT	8	2
Port 6 data direction register	P6DDR	8	H'FFB9	PORT	8	2
Port 5 data register	P5DR	8	H'FFBA	PORT	8	2

Register Name	Abbreviation	Number of Bits	Address	Module	Data Bus Width	Number of Access States
Port 6 data register	P6DR	8	H'FFBB	PORT	8	2
Port B output data register	PBODR	8	H'FFBC	PORT	8	2
Port B input data register	PBPIN	8	H'FFBD (Read)	PORT	8	2
Port 8 data direction register	P8DDR	8	H'FFBD (Write)	PORT	8	2
Port 7 input data register	P7PIN	8	H'FFBE (Read)	PORT	8	2
Port B data direction register	PBDDR	8	H'FFBE (Write)	PORT	8	2
Port 8 data register	P8DR	8	H'FFBF	PORT	8	2
Port 9 data direction register	P9DDR	8	H'FFC0	PORT	8	2
Port 9 data register	P9DR	8	H'FFC1	PORT	8	2
Interrupt enable register	IER	8	H'FFC2	INT	8	2
Serial timer control register	STCR	8	H'FFC3	SYSTEM	8	2
System control register	SYSCR	8	H'FFC4	SYSTEM	8	2
Mode control register	MDCR	8	H'FFC5	SYSTEM	8	2
Bus control register	BCR	8	H'FFC6	BSC	8	2
Wait state control register	WSCR	8	H'FFC7	BSC	8	2
Timer control register_0	TCR_0	8	H'FFC8	TMR_0	16	2
Timer control register_1	TCR_1	8	H'FFC9	TMR_1	16	2
Timer control/status register_0	TCSR_0	8	H'FFCA	TMR_0	16	2
Timer control/status register_1	TCSR_1	8	H'FFCB	TMR_1	16	2
Time constant register A_0	TCORA_0	8	H'FFCC	TMR_0	16	2
Time constant register A_1	TCORA_1	8	H'FFCD	TMR_1	16	2
Time constant register B_0	TCORB_0	8	H'FFCE	TMR_0	16	2
Time constant register B_1	TCORB_1	8	H'FFCF	TMR_1	16	2
Timer counter_0	TCNT_0	8	H'FFD0	TMR_0	16	2
Timer counter_1	TCNT_1	8	H'FFD1	TMR_1	16	2
PWM output enable register B	PWOERB	8	H'FFD2	PWM	8	2
PWM output enable register A	PWOERA	8	H'FFD3	PWM	8	2

Register Name	Abbreviation	Number of Bits	Address	Module	Data Bus Width	Number of Access States
PWM data polarity register B	PWDPRB	8	H'FFD4	PWM	8	2
PWM data polarity register A	PWDPRA	8	H'FFD5	PWM	8	2
PWM register select	PWSL	8	H'FFD6	PWM	8	2
PWM data registers 15 to 0	PWDR15-0	8	H'FFD7	PWM	8	2
Serial mode register_0	SMR_0	8	H'FFD8	SCI_0	8	2
I ² C bus control register_0	ICCR_0	8	H'FFD8	IIC_0	8	2
Bit rate register_0	BRR_0	8	H'FFD9	SCI_0	8	2
I ² C bus status register_0	ICSR_0	8	H'FFD9	IIC_0	8	2
Serial control register_0	SCR_0	8	H'FFDA	SCI_0	8	2
Transmit data register_0	TDR_0	8	H'FFDB	SCI_0	8	2
Serial status register_0	SSR_0	8	H'FFDC	SCI_0	8	2
Receive data register_0	RDR_0	8	H'FFDD	SCI_0	8	2
Smart card mode register_0	SCMR_0	8	H'FFDE	SCI_0	8	2
I ² C bus data register_0	ICDR_0	8	H'FFDE	IIC_0	8	2
Second slave address register_0	SARX_0	8	H'FFDE	IIC_0	8	2
I ² C bus mode register_0	ICMR_0	8	H'FFDF	IIC_0	8	2
Slave address register_0	SAR_0	8	H'FFDF	IIC_0	8	2
A/D data register AH	ADDRAH	8	H'FFE0	A/D converter	8	2
A/D data register AL	ADDRAL	8	H'FFE1	A/D converter	8	2
A/D data register BH	ADDRBH	8	H'FFE2	A/D converter	8	2
A/D data register BL	ADDRBL	8	H'FFE3	A/D converter	8	2
A/D data register CH	ADDRCH	8	H'FFE4	A/D converter	8	2
A/D data register CL	ADDRCL	8	H'FFE5	A/D converter	8	2

Register Name	Abbreviation	Number of Bits	Address	Module	Data Bus Width	Number of Access States
A/D data register DH	ADDRDH	8	H'FFE6	A/D converter	8	2
A/D data register DL	ADDRDL	8	H'FFE7	A/D converter	8	2
A/D control/status register	ADCSR	8	H'FFE8	A/D converter	8	2
A/D control register	ADCR	8	H'FFE9	A/D converter	8	2
Timer control/status register_1	TCSR_1	8	H'FFEA (read)	WDT_1	16	2
Timer control/status register_1	TCSR_1	16	H'FFEA (write)	WDT_1	16	2
Timer counter_1	TCNT_1	8	H'FFEB (read)	WDT_1	16	2
Timer counter_1	TCNT_1	16	H'FFEA (write)	WDT_1	16	2
Timer control register_X	TCR_X	8	H'FFF0	TMR_X	8	2
Timer control register_Y	TCR_Y	8	H'FFF0	TMR_Y	8	2
Keyboard matrix interrupt mask register 6	KMIMR6	8	H'FFF1	INT	8	2
Timer control/status register_X	TCSR_X	8	H'FFF1	TMR_X	8	2
Timer control/status register_Y	TCSR_Y	8	H'FFF1	TMR_Y	8	2
Port 6 pull-up MOS control register	KMPCR6	8	H'FFF2	PORT	8	2
Input capture register R	TICRR	8	H'FFF2	TMR_X	8	2
Time constant register A_Y	TCORA_Y	8	H'FFF2	TMR_Y	8	2
Keyboard matrix interrupt mask register A	KMIMRA	8	H'FFF3	INT	8	2
Input capture register F	TICRF	8	H'FFF3	TMR_X	8	2
Time constant register B_Y	TCORB_Y	8	H'FFF3	TMR_Y	8	2
Wakeup event interrupt mask register 3	WUEMR3	8	H'FFF4	INT	8	2

Register Name	Abbreviation	Number of Bits	Address	Module	Data Bus Width	Number of Access States
Timer counter_X	TCNT_X	8	H'FFF4	TMR_X	8	2
Timer counter_Y	TCNT_Y	8	H'FFF4	TMR_Y	8	2
Time constant register C	TCORC	8	H'FFF5	TMR_X	8	2
Timer input select register	TISR	8	H'FFF5	TMR_Y	8	2
Time constant register A_X	TCORA_X	8	H'FFF6	TMR_X	8	2
Time constant register B_X	TCORB_X	8	H'FFF7	TMR_X	8	2
D/A data register 0	DADR0	8	H'FFF8	D/A converter	8	2
D/A data register 1	DADR1	8	H'FFF9	D/A converter	8	2
D/A control register	DACR	8	H'FFFA	D/A converter	8	2
Timer connection register I	TCONRI	8	H'FFFC	TMR	8	2
Timer connection register S	TCONRS	8	H'FFFE	TMR	8	2

24.2 Register Bits

Register addresses and bit names of the on-chip peripheral modules are described below.

Each line covers eight bits, so 16-bit registers are shown as 2 lines.

Register Abbreviation	Bit 7	Bit 6	Bit 5	Bit 4	Bit 3	Bit 2	Bit 1	Bit 0	Module
HICR4	LADR12SEL	—	—	—	SWENBL	KCSENBL	SMICENBL	BTENBL	LPC
BTSR0	—	—	—	FRDI	HRDI	HWRI	HBTWI	HBTRI	
BTSR1	—	HRSTI	IRQCRI	BEVTI	B2HI	H2BI	CRRPI	CRWPI	
BTCSR0	—	FSEL1	FSEL0	FRDIE	HRDIE	HWRIE	HBTWIE	HBTRIE	
BTCSR1	RSTRENBL	HRSTIE	IRQCRIE	BEVTIE	B2HIE	H2BIE	CRRPIE	CRWPIE	
BTCR	B_BUSY	H_BUSY	OEM0	BEVT_ATN	B2H_ATN	H2B_ATN	CLR_RD_PTR	CLR_WR_PTR	
BTIMSR	BMC_HWRST	—	—	OME3	OME2	OME1	B2H_IRQ	B2H_IRQ_EN	
SMICFLG	RX_DATA_RDY	TX_DATA_RDY	—	SMI	SEVT_ATN	SMS_ATN	—	BUSY	
SMICCSR	Bit 7	Bit 6	Bit 5	Bit 4	Bit 3	Bit 2	Bit 1	Bit 0	
SMICDTR	Bit 7	Bit 6	Bit 5	Bit 4	Bit 3	Bit 2	Bit 1	Bit 0	
SMICIR0	—	—	—	HDTWI	HDTRI	STARI	CTLWI	BUSYI	
SMICIR1	—	—	—	HDTWIE	HDTRIE	STARIE	CTLWIE	BUSYIE	
TWR0MW	Bit 7	Bit 6	Bit 5	Bit 4	Bit 3	Bit 2	Bit 1	Bit 0	
TWR0SW	Bit 7	Bit 6	Bit 5	Bit 4	Bit 3	Bit 2	Bit 1	Bit 0	
TWR1	Bit 7	Bit 6	Bit 5	Bit 4	Bit 3	Bit 2	Bit 1	Bit 0	
TWR2	Bit 7	Bit 6	Bit 5	Bit 4	Bit 3	Bit 2	Bit 1	Bit 0	
TWR3	Bit 7	Bit 6	Bit 5	Bit 4	Bit 3	Bit 2	Bit 1	Bit 0	
TWR4	Bit 7	Bit 6	Bit 5	Bit 4	Bit 3	Bit 2	Bit 1	Bit 0	
TWR5	Bit 7	Bit 6	Bit 5	Bit 4	Bit 3	Bit 2	Bit 1	Bit 0	
TWR6	Bit 7	Bit 6	Bit 5	Bit 4	Bit 3	Bit 2	Bit 1	Bit 0	
TWR7	Bit 7	Bit 6	Bit 5	Bit 4	Bit 3	Bit 2	Bit 1	Bit 0	
TWR8	Bit 7	Bit 6	Bit 5	Bit 4	Bit 3	Bit 2	Bit 1	Bit 0	
TWR9	Bit 7	Bit 6	Bit 5	Bit 4	Bit 3	Bit 2	Bit 1	Bit 0	
TWR10	Bit 7	Bit 6	Bit 5	Bit 4	Bit 3	Bit 2	Bit 1	Bit 0	
TWR11	Bit 7	Bit 6	Bit 5	Bit 4	Bit 3	Bit 2	Bit 1	Bit 0	
TWR12	Bit 7	Bit 6	Bit 5	Bit 4	Bit 3	Bit 2	Bit 1	Bit 0	
TWR13	Bit 7	Bit 6	Bit 5	Bit 4	Bit 3	Bit 2	Bit 1	Bit 0	

Register	Bit 7	Bit 6	Bit 5	Bit 4	Bit 3	Bit 2	Bit 1	Bit 0	Module
TWR14	Bit 7	Bit 6	Bit 5	Bit 4	Bit 3	Bit 2	Bit 1	Bit 0	LPC
TWR15	Bit 7	Bit 6	Bit 5	Bit 4	Bit 3	Bit 2	Bit 1	Bit 0	
IDR3	Bit 7	Bit 6	Bit 5	Bit 4	Bit 3	Bit 2	Bit 1	Bit 0	
ODR3	Bit 7	Bit 6	Bit 5	Bit 4	Bit 3	Bit 2	Bit 1	Bit 0	
STR3* ¹	IBF3B	OBF3B	MWMF	SWMF	C/D ₃	DBU32	IBF3A	OBF3A	
STR3* ²	DBU37	DBU36	DBU35	DBU34	C/D ₃	DBU32	IBF3A	OBF3A	
LADR3H	Bit 15	Bit 14	Bit 13	Bit 12	Bit 11	Bit 10	Bit 9	Bit 8	
LADR3L	Bit 7	Bit 6	Bit 5	Bit 4	Bit 3	—	Bit 1	TWRE	
SIRQCR0	Q/C	SELRE0	IEDIR	SMIE3B	SMIE3A	SMIE2	IRQ12E1	IRQ1E1	
SIRQCR1	IRQ11E3	IRQ10E3	IRQ9E3	IRQ6E3	IRQ11E2	IRQ10E2	IRQ9E2	IRQ6E2	
IDR1	Bit 7	Bit 6	Bit 5	Bit 4	Bit 3	Bit 2	Bit 1	Bit 0	
ODR1	Bit 7	Bit 6	Bit 5	Bit 4	Bit 3	Bit 2	Bit 1	Bit 0	
STR1	DBU17	DBU16	DBU15	DBU14	C/D ₁	DBU12	IBF1	OBF1	
IDR2	Bit 7	Bit 6	Bit 5	Bit 4	Bit 3	Bit 2	Bit 1	Bit 0	
ODR2	Bit 7	Bit 6	Bit 5	Bit 4	Bit 3	Bit 2	Bit 1	Bit 0	
STR2	DBU27	DBU26	DBU25	DBU24	C/D ₂	DBU22	IBF2	OBF2	
HISEL	SELSTR3	SELIRQ11	SELIRQ10	SELIRQ9	SELIRQ6	SELSMI	SELIRQ12	SELIRQ1	
HICR0	LPC3E	LPC2E	LPC1E	FGA20E	SDWNE	PMEE	LSMIE	LSCIE	
HICR1	LPCBSY	CLKREQ	IRQBSY	LRSTB	SDWNB	PMEB	LSMIB	LSCIB	
HICR2	GA20	LRST	SDWN	ABRT	IBFIE3	IBFIE2	IBFIE1	ERRIE	
HICR3	LFRAME	CLKRUN	SERIRQ	LRESET	LPCPD	PME	LSMI	LSCI	
SIRQCR2	IEDIR3	—	—	—	—	—	—	—	
BTDR	Bit 7	Bit 6	Bit 5	Bit 4	Bit 3	Bit 2	Bit 1	Bit 0	
BTFVSR0	N7	N6	N5	N4	N3	N2	N1	N0	
BTFVSR1	N7	N6	N5	N4	N3	N2	N1	N0	
LADR12H	Bit 15	Bit 14	Bit 13	Bit 12	Bit 11	Bit 10	Bit 9	Bit 8	
LADR12L	Bit 7	Bit 6	Bit 5	Bit 4	Bit 3	—	Bit 1	Bit 0	
SUBMSTPAH	SMSTPA15	SMSTPA14	SMSTPA13	SMSTPA12	SMSTPA11	SMSTPA10	SMSTPA9	SMSTPA8	SYSTEM
SUBMSTPAL	SMSTPA7	SMSTPA6	SMSTPA5	SMSTPA4	SMSTPA3	SMSTPA2	SMSTPA1	SMSTPA0	
SUBMSTPBH	SMSTPB15	SMSTPB14	SMSTPB13	SMSTPB12	SMSTPB11	SMSTPB10	SMSTPB9	SMSTPB8	
SUBMSTPBL	SMSTPB7	SMSTPB6	SMSTPB5	SMSTPB4	SMSTPB3	SMSTPB2	SMSTPB1	SMSTPB0	

Register									
Abbreviation	Bit 7	Bit 6	Bit 5	Bit 4	Bit 3	Bit 2	Bit 1	Bit 0	Module
ECS	E15	E14	E13	E12	E11	E10	E9	E8	EVC
	E7	E6	E5	E4	E3	E2	E1	E0	
ECCR	EDSB	—	—	—	ECSB3	ECSB2	ECSB1	ECSB0	
MSTPCRA	MSTPA7	MSTPA6	MSTPA5	MSTPA4	MSTPA3	MSTPA2	MSTPA1	MSTPA0	SYSTEM
P6NCE	P67NCE	P66NCE	P65NCE	P64NCE	P63NCE	P62NCE	P61NCE	P60NCE	PORT
P6NCMC	P67NCMC	P66NCMC	P65NCMC	P64NCMC	P63NCMC	P62NCMC	P61NCMC	P60NCMC	
P6NCCS	—	—	—	—	—	NCKK2	NCKK1	NCKK0	
PEODR	PE7ODR	PE6ODR	PE5ODR	PE4ODR	PE3ODR	PE2ODR	PE1ODR	PE0ODR	
PFODR	—	—	—	—	—	PF2ODR	PF1ODR	PF0ODR	
PEPIN	PE7PIN	PE6PIN	PE5PIN	PE4PIN	PE3PIN	PE2PIN	PE1PIN	PE0PIN	
PEDDR	PE7DDR	PE6DDR	PE5DDR	PE4DDR	PE3DDR	PE2DDR	PE1DDR	PE0DDR	
PFPIN	—	—	—	—	—	PF2PIN	PF1PIN	PF0PIN	
PFDDR	—	—	—	—	—	PF2DDR	PF1DDR	PF0DDR	
PCODR	PC7ODR	PC6ODR	PC5ODR	PC4ODR	PC3ODR	PC2ODR	PC1ODR	PC0ODR	
PDODR	PD7ODR	PD6ODR	PD5ODR	PD4ODR	PD3ODR	PD2ODR	PD1ODR	PD0ODR	
PCPIN	PC7PIN	PC6PIN	PC5PIN	PC4PIN	PC3PIN	PC2PIN	PC1PIN	PC0PIN	
PCDDR	PC7DDR	PC6DDR	PC5DDR	PC4DDR	PC3DDR	PC2DDR	PC1DDR	PC0DDR	
PDPIN	PD7PIN	PD6PIN	PD5PIN	PD4PIN	PD3PIN	PD2PIN	PD1PIN	PD0PIN	
PDDDR	PD7DDR	PD6DDR	PD5DDR	PD4DDR	PD3DDR	PD2DDR	PD1DDR	PD0DDR	
FCCS	FWE	—	—	FLER	WEINTE	—	—	SC0	FLASH
FPCS	—	—	—	—	—	—	—	PPVS	
FECS	—	—	—	—	—	—	—	EPVB	
FKEY	K7	K6	K5	K4	K3	K2	K1	K0	
FMATS	MS7	MS6	MS5	MS4	MS3	MS2	MS1	MS0	
FTDAR	TDER	TDA6	TDA5	TDA4	TDA3	TDA2	TDA1	TDA0	
ICCR_4	ICE	IEIC	MST	TRS	ACKE	BBSY	IRIC	SCP	IIC_4
ICSR_4	ESTP	STOP	IRTR	AASX	AL	AAS	ADZ	ACKB	
ICDR-4	Bit 7	Bit 6	Bit 5	Bit 4	Bit 3	Bit 2	Bit 1	Bit 0	
SARX_4	SVAX6	SVAX5	SVAX4	SVAX3	SVAX2	SVAX1	SVAX0	FSX	
ICMR_4	MLS	WAIT	CKS2	CKS1	CKS0	BC2	BC1	BC0	
SAR_4	SVA6	SVA5	SVA4	SVA3	SVA2	SVA1	SVA0	FS	

Register Abbreviation	Bit 7	Bit 6	Bit 5	Bit 4	Bit 3	Bit 2	Bit 1	Bit 0	Module
ICCR_5	ICE	IEIC	MST	TRS	ACKE	BBSY	IRIC	SCP	IIC_5
ICSR_5	ESTP	STOP	IRTR	AASX	AL	AAS	ADZ	ACKB	
ICDR_5	Bit 7	Bit 6	Bit 5	Bit 4	Bit 3	Bit 2	Bit 1	Bit 0	
SARX_5	SVAX6	SVAX5	SVAX4	SVAX3	SVAX2	SVAX1	SVAX0	FSX	
ICMR_5	MLS	WAIT	CKS2	CKS1	CKS0	BC2	BC1	BC0	
SAR_5	SVA6	SVA5	SVA4	SVA3	SVA2	SVA1	SVA0	FS	
ICCR_3	ICE	IEIC	MST	TRS	ACKE	BBSY	IRIC	SCP	IIC_3
ICSR_3	ESTP	STOP	IRTR	AASX	AL	AAS	ADZ	ACKB	
ICDR_3	Bit 7	Bit 6	Bit 5	Bit 4	Bit 3	Bit 2	Bit 1	Bit 0	
SARX_3	SVAX6	SVAX5	SVAX4	SVAX3	SVAX2	SVAX1	SVAX0	FSX	
ICMR_3	MLS	WAIT	CKS2	CKS1	CKS0	BC2	BC1	BC0	
SAR_3	SVA6	SVA5	SVA4	SVA3	SVA2	SVA1	SVA0	FS	
ICCR_2	ICE	IEIC	MST	TRS	ACKE	BBSY	IRIC	SCP	IIC_2
ICSR_2	ESTP	STOP	IRTR	AASX	AL	AAS	ADZ	ACKB	
ICDR_2	Bit 7	Bit 6	Bit 5	Bit 4	Bit 3	Bit 2	Bit 1	Bit 0	
SARX_2	SVAX6	SVAX5	SVAX4	SVAX3	SVAX2	SVAX1	SVAX0	FSX	
ICMR_2	MLS	WAIT	CKS2	CKS1	CKS0	BC2	BC1	BC0	
SAR_2	SVA6	SVA5	SVA4	SVA3	SVA2	SVA1	SVA0	FS	
DADRA_1	DA13	DA12	DA11	DA10	DA9	DA8	DA7	DA6	PWMX_1
	DA5	DA4	DA3	DA2	DA1	DA0	CFS	—	
DACR_1	—	PWME	—	—	OEB	OEA	OS	CKS	
DADRB_1	DA13	DA12	DA11	DA10	DA9	DA8	DA7	DA6	
	DA5	DA4	DA3	DA2	DA1	DA0	CFS	REGS	
DACNT_1	UC7	UC6	UC5	UC4	UC3	UC2	UC1	UC0	
	UC8	UC9	UC10	UC11	UC12	UC13	—	REGS	
SEMR_0	SSE	—	—	ACS4	ABCS	ACS2	ACS1	ACS0	SCI_0
SEMR_2	SSE	—	—	ACS4	ABCS	ACS2	ACS1	ACS0	SCI_2
CRCCR	DORCLR	—	—	—	—	LMS	G1	G0	CRC
CRCDIR	Bit 7	Bit 6	Bit 5	Bit 4	Bit 3	Bit 2	Bit 1	Bit 0	
CRCDOR	Bit 15	Bit 14	Bit 13	Bit 12	Bit 11	Bit 10	Bit 9	Bit 8	
	Bit 7	Bit 6	Bit 5	Bit 4	Bit 3	Bit 2	Bit 1	Bit 0	
ICXR_0	STOPIM	HNDS	ICDRF	ICDRE	ALIE	ALSL	FNC1	FNC0	IIC_0
ICXR_1	STOPIM	HNDS	ICDRF	ICDRE	ALIE	ALSL	FNC1	FNC0	IIC_1

Register	Bit 7	Bit 6	Bit 5	Bit 4	Bit 3	Bit 2	Bit 1	Bit 0	Module
ICSMBCR	SMB5E	SMB4E	SME3E	SMB2E	SMB1E	SMB0E	FSEL1	FSEL0	IIC
ICXR_2	STOPIM	HNDS	ICDRF	ICDRE	ALIE	ALSL	FNC1	FNC0	IIC_2
ICXR_3	STOPIM	HNDS	ICDRF	ICDRE	ALIE	ALSL	FNC1	FNC0	IIC_3
IICX3	—	—	—	—	TCSS	IICX5	IICX4	IICX3	IIC
ICXR_4	STOPIM	HNDS	ICDRF	ICDRE	ALIE	ALSL	FNC1	FNC0	IIC_4
ICXR_5	STOPIM	HNDS	ICDRF	ICDRE	ALIE	ALSL	FNC1	FNC0	IIC_5
KBCOMP	EVENTE	—	—	—	—	—	—	—	EVC
SCICR	IrE	IrCKS2	IrCKS1	IrCKS0	—	—	—	—	SCI_1
ICRD	ICRD7	ICRD7	—	—	—	—	—	—	INT
ICRA	ICRA7	ICRA6	ICRA5	ICRA4	ICRA3	ICRA2	ICRA1	ICRA0	
ICRB	ICRB7	ICRB6	—	ICRB4	ICRB3	ICRB2	ICRB1	ICRB0	
ICRC	ICRC7	ICRC6	ICRC5	ICRC4	ICRC3	ICRC2	ICRC1	—	
ISR	IRQ7F	IRQ6F	IRQ5F	IRQ4F	IRQ3F	IRQ2F	IRQ1F	IRQ0F	
ISCRH	IRQ7SCB	IRQ7SCA	IRQ6SCB	IRQ6SCA	IRQ5SCB	IRQ5SCA	IRQ4SCB	IRQ4SCA	
ISCR_L	IRQ3SCB	IRQ3SCA	IRQ2SCB	IRQ2SCA	IRQ1SCB	IRQ1SCA	IRQ0SCB	IRQ0SCA	
DTCERA	DTCEA7	DTCEA6	DTCEA5	DTCEA4	DTCEA3	DTCEA2	DTCEA1	DTCEA0	DTC
DTCERB	DTCEB7	DTCEB6	DTCEB5	—	—	DTCEB2	DTCEB1	DTCEB0	
DTCERC	DTCEC7	DTCEC6	DTCEC5	DTCEC4	DTCEC3	DTCEC2	DTCEC1	DTCEC0	
DTCERD	DTCED7	DTCED6	DTCED5	DTCED4	DTCED3	—	—	DTCED0	
DTCERE	—	—	—	—	DTCEE3	DTCEE2	DTCEE1	DTCEE0	
DTVECR	SWDTE	DTVEC6	DTVEC5	DTVEC4	DTVEC3	DTVEC2	DTVEC1	DTVEC0	
ABRKCR	CMF	—	—	—	—	—	—	BIE	INT
BARA	A23	A22	A21	A20	A19	A18	A17	A16	
BARB	A15	A14	A13	A12	A11	A10	A9	A8	
BARC	A7	A6	A5	A4	A3	A2	A1	—	
IER16	IRQ15E	IRQ14E	IRQ13E	IRQ12E	IRQ11E	IRQ10E	IRQ9E	IRQ8E	
ISR16	IRQ15F	IRQ14F	IRQ13F	IRQ12F	IRQ11F	IRQ10F	IRQ9F	IRQ8F	
ISCR16H	IRQ15SCB	IRQ15SCA	IRQ14SCB	IRQ14SCA	IRQ13SCB	IRQ13SCA	IRQ12SCB	IRQ12SCA	
ISCR16L	IRQ11SCB	IRQ11SCA	IRQ10SCB	IRQ10SCA	IRQ9SCB	IRQ9SCA	IRQ8SCB	IRQ8SCA	
ISSR16	ISS15	ISS14	ISS13	ISS12	ISS11	ISS0	ISS9	ISS8	PORT
ISSR	ISS7	ISS6	ISS5	ISS4	ISS3	ISS2	ISS1	ISS0	
PTCNT0	TMI0S	TMI1S	TMIXS	TMIYS	—	PWMS	—	—	

Register	Bit 7	Bit 6	Bit 5	Bit 4	Bit 3	Bit 2	Bit 1	Bit 0	Module
BCR2	—	—	ABWCP	ASTCP	ADFULLE	EXCKS	—	CPCSE	BSC
WSCR2	WMS10	WC11	WC10	WMS21	WMS20	WC22	WC21	WC20	
PCSR	PWCKX1B	PWCKX1A	PWCKX0B	PWCKX0A	PWCKX1C	PWCKB	PWCKA	PWCKX0C	PWM
SYSCR2	—	—	P6PUE	—	ADMXE	—	—	—	SYSTEM
SBYCR	SSBY	STS2	STS1	STS0	DTSPEED	SCK2	SCK1	SCK0	
LPWRCR	DTON	LSON	NESEL	EXCLE	—	PNCCS	PNCAH	—	
MSTPCRH	MSTP15	MSTP14	MSTP13	MSTP12	MSTP11	MSTP10	MSTP9	MSTP8	
MSTPCRL	MSTP7	MSTP6	MSTP5	MSTP4	MSTP3	MSTP2	MSTP1	MSTP0	
SMR_1* ³	C/Ā (GM)	CHR (BLK)	PE (PE)	O/Ē (O/E)	STOP (BCP1)	MP (BCP0)	CKS1 (CKS1)	CKS0 (CKS0)	SCI_1
ICCR_1	ICE	IEIC	MST	TRS	ACKE	BBSY	IRIC	SCP	IIC_1
BRR_1	Bit 7	Bit 6	Bit 5	Bit 4	Bit 3	Bit 2	Bit 1	Bit 0	SCI_1
ICSR_1	ESTP	STOP	IRTR	AASX	AL	AAS	ADZ	ACKB	IIC_1
SCR_1	TIE	RIE	TE	RE	MPIE	TEIE	CKE1	CKE0	SCI_1
TDR_1	Bit 7	Bit 6	Bit 5	Bit 4	Bit 3	Bit 2	Bit 1	Bit 0	
SSR_1* ³	TDRE (TDRE)	RDRF (RDRF)	ORER (ORER)	FER (ERS)	PER (PER)	TEND (TEND)	MPB (MPB)	MPBT (MPBT)	
RDR_1	Bit 7	Bit 6	Bit 5	Bit 4	Bit 3	Bit 2	Bit 1	Bit 0	
SCMR_1	—	—	—	—	SDIR	SINV	—	SMIF	
ICDR_1	Bit 7	Bit 6	Bit 5	Bit 4	Bit 3	Bit 2	Bit 1	Bit 0	IIC_1
SARX_1	SVAX6	SVAX5	SVAX4	SVAX3	SVAX2	SVAX1	SVAX0	FSX	
ICMR_1	MLS	WAIT	CKS2	CKS1	CKS0	BC2	BC1	BC0	
SAR_1	SVA6	SVA5	SVA4	SVA3	SVA2	SVA1	SVA0	FS	
TIER	ICIAE	ICIBE	ICICE	ICIDE	OCIAE	OCIBE	OVIE	—	FRT
TCSR	ICFA	ICFB	ICFC	ICFD	OCFA	OCFB	OVF	CCLRA	
FRC	Bit 15	Bit 14	Bit 13	Bit 12	Bit 11	Bit 10	Bit 9	Bit 8	
	Bit 7	Bit 6	Bit 5	Bit 4	Bit 3	Bit 2	Bit 1	Bit 0	
OCRA	Bit 15	Bit 14	Bit 13	Bit 12	Bit 11	Bit 10	Bit 9	Bit 8	
	Bit 7	Bit 6	Bit 5	Bit 4	Bit 3	Bit 2	Bit 1	Bit 0	
OCRB	Bit 15	Bit 14	Bit 13	Bit 12	Bit 11	Bit 10	Bit 9	Bit 8	
	Bit 7	Bit 6	Bit 5	Bit 4	Bit 3	Bit 2	Bit 1	Bit 0	
TCR	IEDGA	IEDGB	IEDGC	IEDGD	BUFEA	BUFEB	CKS1	CKS0	
TOCR	ICRDMS	OCRAMS	ICRS	OCRS	OEA	OEB	OLVLA	OLVLB	

Register									
Abbreviation	Bit 7	Bit 6	Bit 5	Bit 4	Bit 3	Bit 2	Bit 1	Bit 0	Module
ICRA	Bit 15	Bit 14	Bit 13	Bit 12	Bit 11	Bit 10	Bit 9	Bit 8	FRT
	Bit 7	Bit 6	Bit 5	Bit 4	Bit 3	Bit 2	Bit 1	Bit 0	
OCRAR	Bit 15	Bit 14	Bit 13	Bit 12	Bit 11	Bit 10	Bit 9	Bit 8	
	Bit 7	Bit 6	Bit 5	Bit 4	Bit 3	Bit 2	Bit 1	Bit 0	
ICRB	Bit 15	Bit 14	Bit 13	Bit 12	Bit 11	Bit 10	Bit 9	Bit 8	
	Bit 7	Bit 6	Bit 5	Bit 4	Bit 3	Bit 2	Bit 1	Bit 0	
OCRRAF	Bit 15	Bit 14	Bit 13	Bit 12	Bit 11	Bit 10	Bit 9	Bit 8	
	Bit 7	Bit 6	Bit 5	Bit 4	Bit 3	Bit 2	Bit 1	Bit 0	
ICRC	Bit 15	Bit 14	Bit 13	Bit 12	Bit 11	Bit 10	Bit 9	Bit 8	
	Bit 7	Bit 6	Bit 5	Bit 4	Bit 3	Bit 2	Bit 1	Bit 0	
OCRDM	Bit 15	Bit 14	Bit 13	Bit 12	Bit 11	Bit 10	Bit 9	Bit 8	
	Bit 7	Bit 6	Bit 5	Bit 4	Bit 3	Bit 2	Bit 1	Bit 0	
ICRD	Bit 15	Bit 14	Bit 13	Bit 12	Bit 11	Bit 10	Bit 9	Bit 8	
	Bit 7	Bit 6	Bit 5	Bit 4	Bit 3	Bit 2	Bit 1	Bit 0	
SMR_2* ³	C/ \bar{A} (GM)	CHR (BLK)	PE (PE)	O/ \bar{E} (O/ \bar{E})	STOP (BCP1)	MP (BCP0)	CKS1 (CKS1)	CKS0 (CKS0)	SCI_2
DACR_0	—	PWME	—	—	OEB	OEA	OS	CKS	PWMX_0
DADRA_0	DA13	DA12	DA11	DA10	DA9	DA8	DA7	DA6	
	DA5	DA4	DA3	DA2	DA1	DA0	CFS	—	
BRR_2	Bit 7	Bit 6	Bit 5	Bit 4	Bit 3	Bit 2	Bit 1	Bit 0	SCI_2
SCR_2	TIE	RIE	TE	RE	MPIE	TEIE	CKE1	CKE0	
TDR_2	Bit 7	Bit 6	Bit 5	Bit 4	Bit 3	Bit 2	Bit 1	Bit 0	
SSR_2* ³	TDRE (TDRE)	RDRF (RDRF)	ORER (ORER)	FER (ERS)	PER (PER)	TEND (TEND)	MPB (MPB)	MPBT (MPBT)	
RDR_2	Bit 7	Bit 6	Bit 5	Bit 4	Bit 3	Bit 2	Bit 1	Bit 0	
SCMR_2	—	—	—	—	SDIR	SINV	—	SMIF	
DADRB_0	DA13	DA12	DA11	DA10	DA9	DA8	DA7	DA6	PWMX_0
	DA5	DA4	DA3	DA2	DA1	DA0	CFS	REGS	
DACNT_0	UC7	UC6	UC5	UC4	UC3	UC2	UC1	UC0	
	UC8	UC9	UC10	UC11	UC12	UC13	—	REGS	
TCSR_0	OVF	WT/ \bar{IT}	TME	—	RST/ \bar{NMI}	CKS2	CKS1	CKS0	WDT_0
TCNT_0	Bit 7	Bit 6	Bit 5	Bit 4	Bit 3	Bit 2	Bit 1	Bit 0	

Register									Module
Abbreviation	Bit 7	Bit 6	Bit 5	Bit 4	Bit 3	Bit 2	Bit 1	Bit 0	
PAODR	PA7ODR	PA6ODR	PA5ODR	PA4ODR	PA3ODR	PA2ODR	PA1ODR	PA0ODR	PORT
PAPIN	PA7PIN	PA6PIN	PA5PIN	PA4PIN	PA3PIN	PA2PIN	PA1PIN	PA0PIN	
PADDR	PA7DDR	PA6DDR	PA5DDR	PA4DDR	PA3DDR	PA2DDR	PA1DDR	PA0DDR	
P1PCR	P17PCR	P16PCR	P15PCR	P14PCR	P13PCR	P12PCR	P11PCR	P10PCR	
P2PCR	P27PCR	P26PCR	P25PCR	P24PCR	P23PCR	P22PCR	P21PCR	P20PCR	
P3PCR	P37PCR	P36PCR	P35PCR	P34PCR	P33PCR	P32PCR	P31PCR	P30PCR	
P1DDR	P17DDR	P16DDR	P15DDR	P14DDR	P13DDR	P12DDR	P11DDR	P10DDR	
P2DDR	P27DDR	P26DDR	P25DDR	P24DDR	P23DDR	P22DDR	P21DDR	P20DDR	
P1DR	P17DR	P16DR	P15DR	P14DR	P13DR	P12DR	P11DR	P10DR	
P2DR	P27DR	P26DR	P25DR	P24DR	P23DR	P22DR	P21DR	P20DR	
P3DDR	P37DDR	P36DDR	P35DDR	P34DDR	P33DDR	P32DDR	P31DDR	P30DDR	
P4DDR	P47DDR	P46DDR	P45DDR	P44DDR	P43DDR	P42DDR	P41DDR	P40DDR	
P3DR	P37DR	P36DR	P35DR	P34DR	P33DR	P32DR	P31DR	P30DR	
P4DR	P47DR	P46DR	P45DR	P44DR	P43DR	P42DR	P41DR	P40DR	
P5DDR	P57DDR	P56DDR	P55DDR	P54DDR	P53DDR	P52DDR	P51DDR	P50DDR	
P6DDR	P67DDR	P66DDR	P65DDR	P64DDR	P63DDR	P62DDR	P61DDR	P60DDR	
P5DR	P57DR	P56DR	P55DR	P54DR	P53DR	P52DR	P51DR	P50DR	
P6DR	P67DR	P66DR	P65DR	P64DR	P63DR	P62DR	P61DR	P60DR	
PBODR	PB7ODR	PB6ODR	PB5ODR	PB4ODR	PB3ODR	PB2ODR	PB1ODR	PB0ODR	
PBPIN	PB7PIN	PB6PIN	PB5PIN	PB4PIN	PB3PIN	PB2PIN	PB1PIN	PB0PIN	
P8DDR	P87DDR	P86DDR	P85DDR	P84DDR	P83DDR	P82DDR	P81DDR	P80DDR	
P7PIN	P77PIN	P76PIN	P75PIN	P74PIN	P73PIN	P72PIN	P71PIN	P70PIN	
PBDDR	PB7DDR	PB6DDR	PB5DDR	PB4DDR	PB3DDR	PB2DDR	PB1DDR	PB0DDR	
P8DR	P87DR	P86DR	P85DR	P84DR	P83DR	P82DR	P81DR	P80DR	
P9DDR	P97DDR	P96DDR	P95DDR	P94DDR	P93DDR	P92DDR	P91DDR	P90DDR	
P9DR	P97DR	P96DR	P95DR	P94DR	P93DR	P92DR	P91DR	P90DR	
IER	IRQ7E	IRQ6E	IRQ5E	IRQ4E	IRQ3E	IRQ2E	IRQ1E	IRQ0E	INT
STCR	IICX2	IICX1	IICX0	IICE	FLSHE	—	ICKS1	ICKS0	SYSTEM
SYSCR	CS256E	IOSE	INTM1	INTM0	XRST	NMIEG	KINWUE	RAME	
MDCR	EXPE	—	—	—	—	MDS2	MDS1	MDS0	
BCR	—	ICIS	BRSTRM	BRSTS1	BRSTS0	—	IOS1	IOS0	BSC
WSCR	ABW256	AST256	ABW	AST	WMS1	WMS0	WC1	WC0	

Register									
Abbreviation	Bit 7	Bit 6	Bit 5	Bit 4	Bit 3	Bit 2	Bit 1	Bit 0	Module
TCR_0	CMIEB	CMIEA	OVIE	CCLR1	CCLR0	CKS2	CKS1	CKS0	TMR_0,
TCR_1	CMIEB	CMIEA	OVIE	CCLR1	CCLR0	CKS2	CKS1	CKS0	TMR_1
TCSR_0	CMFB	CMFA	OVF	ADTE	OS3	OS2	OS1	OS0	
TCSR_1	CMFB	CMFA	OVF	—	OS3	OS2	OS1	OS0	
TCORA_0	Bit 7	Bit 6	Bit 5	Bit 4	Bit 3	Bit 2	Bit 1	Bit 0	
TCORA_1	Bit 7	Bit 6	Bit 5	Bit 4	Bit 3	Bit 2	Bit 1	Bit 0	
TCORB_0	Bit 7	Bit 6	Bit 5	Bit 4	Bit 3	Bit 2	Bit 1	Bit 0	
TCORB_1	Bit 7	Bit 6	Bit 5	Bit 4	Bit 3	Bit 2	Bit 1	Bit 0	
TCNT_0	Bit 7	Bit 6	Bit 5	Bit 4	Bit 3	Bit 2	Bit 1	Bit 0	
TCNT_1	Bit 7	Bit 6	Bit 5	Bit 4	Bit 3	Bit 2	Bit 1	Bit 0	
PWOERB	OE15	OE14	OE13	OE12	OE11	OE10	OE9	OE8	PWM
PWOERA	OE7	OE6	OE5	OE4	OE3	OE2	OE1	OE0	
PWDPRB	OS15	OS14	OS13	OS12	OS11	OS10	OS9	OS8	
PWDPRA	OS7	OS6	OS5	OS4	OS3	OS2	OS1	OS0	
PWSL	PWCKE	PWCKS	—	—	RS3	RS2	RS1	RS0	
PWDR15-0	Bit 7	Bit 6	Bit 5	Bit 4	Bit 3	Bit 2	Bit 1	Bit 0	
SMR_0*3	C/A (GM)	CHR (BLK)	PE (PE)	O/E (O/E)	STOP (BCP1)	MP (BCP0)	CKS1 (CKS1)	CKS0 (CKS0)	SCI_0
ICCR_0	ICE	IEIC	MST	TRS	ACKE	BBSY	IRIC	SCP	IIC_0
BRR_0	Bit 7	Bit 6	Bit 5	Bit 4	Bit 3	Bit 2	Bit 1	Bit 0	SCI_0
ICSR_0	ESTP	STOP	IRTR	AASX	AL	AAS	ADZ	ACKB	IIC_0
SCR_0	TIE	RIE	TE	RE	MPIE	TEIE	CKE1	CKE0	SCI_0
TDR_0	Bit 7	Bit 6	Bit 5	Bit 4	Bit 3	Bit 2	Bit 1	Bit 0	
SSR_0*3	TDRE (TDRE)	RDRF (RDRF)	ORER (ORER)	FER (ERS)	PER (PER)	TEND (TEND)	MPB (MPB)	MPBT (MPBT)	
RDR_0	Bit 7	Bit 6	Bit 5	Bit 4	Bit 3	Bit 2	Bit 1	Bit 0	
SCMR_0	—	—	—	—	SDIR	SINV	—	SMIF	
ICDR_0	Bit 7	Bit 6	Bit 5	Bit 4	Bit 3	Bit 2	Bit 1	Bit 0	IIC_0
SARX_0	SVAX6	SVAX5	SVAX4	SVAX3	SVAX2	SVAX1	SVAX0	FSX	
ICMR_0	MLS	WAIT	CKS2	CKS1	CKS0	BC2	BC1	BC0	
SAR_0	SVA6	SVA5	SVA4	SVA3	SVA2	SVA1	SVA0	FS	

Register	Bit 7	Bit 6	Bit 5	Bit 4	Bit 3	Bit 2	Bit 1	Bit 0	Module
ADDRAH	AD9	AD8	AD7	AD6	AD5	AD4	AD3	AD2	A/D converter
ADDRAL	AD1	AD0	—	—	—	—	—	—	
ADDRBH	AD9	AD8	AD7	AD6	AD5	AD4	AD3	AD2	
ADDRBL	AD1	AD0	—	—	—	—	—	—	
ADDRCH	AD9	AD8	AD7	AD6	AD5	AD4	AD3	AD2	
ADDRCL	AD1	AD0	—	—	—	—	—	—	
ADDRDH	AD9	AD8	AD7	AD6	AD5	AD4	AD3	AD2	
ADDRDL	AD1	AD0	—	—	—	—	—	—	
ADCSR	ADF	ADIE	ADST	SCAN	CKS	CH2	CH1	CH0	
ADCR	TRGS1	TRGS0	—	—	—	—	—	—	
TCSR_1	OVF	WT/IT	TME	PSS	RST/NMI	CKS2	CKS1	CKS0	WDT_1
TCNT_1	Bit 7	Bit 6	Bit 5	Bit 4	Bit 3	Bit 2	Bit 1	Bit 0	
TCR_X	CMIEB	CMIEA	OVIE	CCLR1	CCLR0	CKS2	CKS1	CKS0	
TCR_Y	CMIEB	CMIEA	OVIE	CCLR1	CCLR0	CKS2	CKS1	CKS0	TMR_Y
KMIMR6	KMIM7	KMIM6	KMIM5	KMIM4	KMIM3	KMIM2	KMIM1	KMIM0	INT
TCSR_X	CMFB	CMFA	OVF	ICF	OS3	OS2	OS1	OS0	TMR_X
TCSR_Y	CMFB	CMFA	OVF	ICIE	OS3	OS2	OS1	OS0	TMR_Y
KMPCR6	KM7PCR	KM6PCR	KM5PCR	KM4PCR	KM3PCR	KM2PCR	KM1PCR	KM0PCR	PORT
TICRR	Bit 7	Bit 6	Bit 5	Bit 4	Bit 3	Bit 2	Bit 1	Bit 0	TMR_X
TCORA_Y	Bit 7	Bit 6	Bit 5	Bit 4	Bit 3	Bit 2	Bit 1	Bit 0	TMR_Y
KMIMRA	KMIM15	KMIM14	KMIM13	KMIM12	KMIM11	KMIM10	KMIM9	KMIM8	INT
TICRF	Bit 7	Bit 6	Bit 5	Bit 4	Bit 3	Bit 2	Bit 1	Bit 0	TMR_X
TCORB_Y	Bit 7	Bit 6	Bit 5	Bit 4	Bit 3	Bit 2	Bit 1	Bit 0	TMR_Y
WUEMR3	WUEM15	WUEM14	WUEM13	WUEM12	WUEM11	WUEM10	WUEM9	WUEM8	INT
TCNT_X	Bit 7	Bit 6	Bit 5	Bit 4	Bit 3	Bit 2	Bit 1	Bit 0	TMR_X
TCNT_Y	Bit 7	Bit 6	Bit 5	Bit 4	Bit 3	Bit 2	Bit 1	Bit 0	TMR_Y
TCORC	Bit 7	Bit 6	Bit 5	Bit 4	Bit 3	Bit 2	Bit 1	Bit 0	TMR_X
TISR	—	—	—	—	—	—	—	IS	TMR_Y
TCORA_X	Bit 7	Bit 6	Bit 5	Bit 4	Bit 3	Bit 2	Bit 1	Bit 0	TMR_X
TCORB_X	Bit 7	Bit 6	Bit 5	Bit 4	Bit 3	Bit 2	Bit 1	Bit 0	
DADR0	Bit 7	Bit 6	Bit 5	Bit 4	Bit 3	Bit 2	Bit 1	Bit 0	D/A converter
DADR1	Bit 7	Bit 6	Bit 5	Bit 4	Bit 3	Bit 2	Bit 1	Bit 0	
DACR	DAOE1	DAOE0	DAE	—	—	—	—	—	

Register

Abbreviation	Bit 7	Bit 6	Bit 5	Bit 4	Bit 3	Bit 2	Bit 1	Bit 0	Module
TCONRI	—	—	—	ICST	—	—	—	—	TMR
TCONRS	TMRX/Y	—	—	—	—	—	—	—	

- Notes:
1. When TWRE = 1 or SELSTR3 = 0
 2. When TWRE = 0 and SELSTR3 = 1
 3. Some Bits have different names in normal mode and smart card interface mode. The Bit name in smart card interface mode is enclosed in parentheses.

24.3 Register States in Each Operating Mode

Register Abbreviation	Reset	High-Speed/ Medium-Speed					Module Stop	Software Standby	Hardware Standby	Module
		Speed	Watch	Sleep	Sub-Active	Sub-Sleep				
HICR4	Initialized	—	—	—	—	—	—	—	Initialized	LPC
BTSR0	Initialized	—	—	—	—	—	—	—	Initialized	
BTSR1	Initialized	—	—	—	—	—	—	—	Initialized	
BTCSR0	Initialized	—	—	—	—	—	—	—	Initialized	
BTCSR1	Initialized	—	—	—	—	—	—	—	Initialized	
BTCR	Initialized	—	—	—	—	—	—	—	Initialized	
BTIMSR	Initialized	—	—	—	—	—	—	—	Initialized	
SMICFLG	Initialized	—	—	—	—	—	—	—	Initialized	
SMICCSR	—	—	—	—	—	—	—	—	—	
SMICDTR	—	—	—	—	—	—	—	—	—	
SMICIR0	Initialized	—	—	—	—	—	—	—	Initialized	
SMICIR1	Initialized	—	—	—	—	—	—	—	Initialized	
TWR0MW	—	—	—	—	—	—	—	—	—	
TWR0SW	—	—	—	—	—	—	—	—	—	
TWR1	—	—	—	—	—	—	—	—	—	
TWR2	—	—	—	—	—	—	—	—	—	
TWR3	—	—	—	—	—	—	—	—	—	
TWR4	—	—	—	—	—	—	—	—	—	
TWR5	—	—	—	—	—	—	—	—	—	
TWR6	—	—	—	—	—	—	—	—	—	
TWR7	—	—	—	—	—	—	—	—	—	
TWR8	—	—	—	—	—	—	—	—	—	
TWR9	—	—	—	—	—	—	—	—	—	
TWR10	—	—	—	—	—	—	—	—	—	
TWR11	—	—	—	—	—	—	—	—	—	
TWR12	—	—	—	—	—	—	—	—	—	
TWR13	—	—	—	—	—	—	—	—	—	
TWR14	—	—	—	—	—	—	—	—	—	
TWR15	—	—	—	—	—	—	—	—	—	
IDR3	—	—	—	—	—	—	—	—	—	
ODR3	—	—	—	—	—	—	—	—	—	

Register Abbrevia- tion	Reset	High-Speed/ Medium-					Module Stop	Software Standby	Hardware Standby	Module
		Speed	Watch	Sleep	Sub-Active	Sub-Sleep				
STR3	Initialized	—	—	—	—	—	—	—	Initialized	LPC
LADR3H	Initialized	—	—	—	—	—	—	—	Initialized	
LADR3L	Initialized	—	—	—	—	—	—	—	Initialized	
SIRQCR0	Initialized	—	—	—	—	—	—	—	Initialized	
SIRQCR1	Initialized	—	—	—	—	—	—	—	Initialized	
IDR1	—	—	—	—	—	—	—	—	—	
ODR1	—	—	—	—	—	—	—	—	—	
STR1	Initialized	—	—	—	—	—	—	—	Initialized	
IDR2	—	—	—	—	—	—	—	—	—	
ODR2	—	—	—	—	—	—	—	—	—	
STR2	Initialized	—	—	—	—	—	—	—	Initialized	
HISEL	Initialized	—	—	—	—	—	—	—	Initialized	
HICR0	Initialized	—	—	—	—	—	—	—	Initialized	
HICR1	Initialized	—	—	—	—	—	—	—	Initialized	
HICR2	Initialized	—	—	—	—	—	—	—	Initialized	
HICR3	—	—	—	—	—	—	—	—	—	
SIRQCR2	Initialized	—	—	—	—	—	—	—	Initialized	
BTDR	—	—	—	—	—	—	—	—	—	
BTFVSR0	Initialized	—	—	—	—	—	—	—	Initialized	
BTFVSR1	Initialized	—	—	—	—	—	—	—	Initialized	
LADR12H	Initialized	—	—	—	—	—	—	—	Initialized	
LADR12L	Initialized	—	—	—	—	—	—	—	Initialized	
SUBMSTPAH	Initialized	—	—	—	—	—	—	—	Initialized	SYSTEM
SUBMSTPAL	Initialized	—	—	—	—	—	—	—	Initialized	
SUBMSTPBH	Initialized	—	—	—	—	—	—	—	Initialized	
SUBMSTPBL	Initialized	—	—	—	—	—	—	—	Initialized	
ECS	Initialized	—	—	—	—	—	—	—	Initialized	EVC
ECCR	Initialized	—	—	—	—	—	—	—	Initialized	
MSTPCRA	Initialized	—	—	—	—	—	—	—	Initialized	SYSTEM

Register Abbrevia- tion	Reset	High-Speed/ Medium-					Module Stop	Software Standby	Hardware Standby	Module
		Speed	Watch	Sleep	Sub-Active	Sub-Sleep				
P6NCE	Initialized	—	—	—	—	—	—	—	Initialized	PORT
P6NCMC	Initialized	—	—	—	—	—	—	—	Initialized	
P6NCCS	Initialized	—	—	—	—	—	—	—	Initialized	
PEODR	Initialized	—	—	—	—	—	—	—	Initialized	
PFODR	Initialized	—	—	—	—	—	—	—	Initialized	
PEPIN	—	—	—	—	—	—	—	—	—	
PEDDR	Initialized	—	—	—	—	—	—	—	Initialized	
PFPIN	—	—	—	—	—	—	—	—	—	
PFDDR	Initialized	—	—	—	—	—	—	—	Initialized	
PCODR	Initialized	—	—	—	—	—	—	—	Initialized	
PDO DR	Initialized	—	—	—	—	—	—	—	Initialized	
PCPIN	—	—	—	—	—	—	—	—	—	
PCDDR	Initialized	—	—	—	—	—	—	—	Initialized	
PDPIN	—	—	—	—	—	—	—	—	—	
PDDDR	Initialized	—	—	—	—	—	—	—	Initialized	
FCCS	Initialized	—	—	—	—	—	—	—	Initialized	FLASH
FPCS	Initialized	—	—	—	—	—	—	—	Initialized	
FECS	Initialized	—	—	—	—	—	—	—	Initialized	
FKEY	Initialized	—	—	—	—	—	—	—	Initialized	
FMATS	Initialized	—	—	—	—	—	—	—	Initialized	
FTDAR	Initialized	—	—	—	—	—	—	—	Initialized	
ICCR_4	Initialized	—	—	—	—	—	—	—	Initialized	IIC_4
ICSR_4	Initialized	—	—	—	—	—	—	—	Initialized	
ICDR_4	—	—	—	—	—	—	—	—	—	
SARX_4	Initialized	—	—	—	—	—	—	—	Initialized	
ICMR_4	Initialized	—	—	—	—	—	—	—	Initialized	
SAR_4	Initialized	—	—	—	—	—	—	—	Initialized	
ICCR_5	Initialized	—	—	—	—	—	—	—	Initialized	IIC_5
ICSR_5	Initialized	—	—	—	—	—	—	—	Initialized	
ICDR_5	—	—	—	—	—	—	—	—	—	
SARX_5	Initialized	—	—	—	—	—	—	—	Initialized	
ICMR_5	Initialized	—	—	—	—	—	—	—	Initialized	
SAR_5	Initialized	—	—	—	—	—	—	—	Initialized	

Register Abbrevia- tion	Reset	High-Speed/ Medium-					Module Stop	Software Standby	Hardware Standby	Module
		Speed	Watch	Sleep	Sub-Active	Sub-Sleep				
ICCR_3	Initialized	—	—	—	—	—	—	—	Initialized	IIC_3
ICSR_3	Initialized	—	—	—	—	—	—	—	Initialized	
ICDR_3	—	—	—	—	—	—	—	—	—	
SARX_3	Initialized	—	—	—	—	—	—	—	Initialized	
ICMR_3	Initialized	—	—	—	—	—	—	—	Initialized	
SAR_3	Initialized	—	—	—	—	—	—	—	Initialized	
ICCR_2	Initialized	—	—	—	—	—	—	—	Initialized	IIC_2
ICSR_2	Initialized	—	—	—	—	—	—	—	Initialized	
ICDR_2	—	—	—	—	—	—	—	—	—	
SARX_2	Initialized	—	—	—	—	—	—	—	Initialized	
ICMR_2	Initialized	—	—	—	—	—	—	—	Initialized	
SAR_2	Initialized	—	—	—	—	—	—	—	Initialized	
DADRA_1	Initialized	—	Initialized	—	Initialized	Initialized	Initialized	Initialized	Initialized	PWMX_1
DACR_1	Initialized	—	Initialized	—	Initialized	Initialized	Initialized	Initialized	Initialized	
DADRB_1	Initialized	—	Initialized	—	Initialized	Initialized	Initialized	Initialized	Initialized	
DACNT_1	Initialized	—	Initialized	—	Initialized	Initialized	Initialized	Initialized	Initialized	
SEMR_0	Initialized	—	—	—	—	—	—	—	Initialized	SCI_0
SEMR_2	Initialized	—	—	—	—	—	—	—	Initialized	SCI_2
CRCCR	Initialized	—	—	—	—	—	—	—	Initialized	CRC
CRCDIR	Initialized	—	—	—	—	—	—	—	Initialized	
CRCDOR	Initialized	—	—	—	—	—	—	—	Initialized	
ICXR_0	Initialized	—	—	—	—	—	—	—	Initialized	IIC_0
ICXR_1	Initialized	—	—	—	—	—	—	—	Initialized	IIC_1
ICSMBCR	initialized	—	—	—	—	—	—	—	Initialized	IIC
ICXR_2	Initialized	—	—	—	—	—	—	—	Initialized	IIC_2
ICXR_3	Initialized	—	—	—	—	—	—	—	Initialized	IIC_3
IICX3	Initialized	—	—	—	—	—	—	—	Initialized	IIC
ICXR_4	Initialized	—	—	—	—	—	—	—	Initialized	IIC_4
ICXR_5	Initialized	—	—	—	—	—	—	—	Initialized	IIC_5
KBCOMP	Initialized	—	—	—	—	—	—	—	Initialized	EVC
SCICR	Initialized	—	—	—	—	—	—	—	Initialized	SCI_1
ICRD	Initialized	—	—	—	—	—	—	—	Initialized	INT

Register Abbrevia- tion	Reset	High-Speed/ Medium-					Module Stop	Software Standby	Hardware Standby	Module
		Speed	Watch	Sleep	Sub-Active	Sub-Sleep				
ICRA	Initialized	—	—	—	—	—	—	—	Initialized	INT
ICRB	Initialized	—	—	—	—	—	—	—	Initialized	
ICRC	Initialized	—	—	—	—	—	—	—	Initialized	
ISR	Initialized	—	—	—	—	—	—	—	Initialized	
ISCRH	Initialized	—	—	—	—	—	—	—	Initialized	
ISCR_L	Initialized	—	—	—	—	—	—	—	Initialized	
DTCERA	Initialized	—	—	—	—	—	—	—	Initialized	DTC
DTCERB	Initialized	—	—	—	—	—	—	—	Initialized	
DTCERC	Initialized	—	—	—	—	—	—	—	Initialized	
DTCERD	Initialized	—	—	—	—	—	—	—	Initialized	
DTCERE	Initialized	—	—	—	—	—	—	—	Initialized	
DTVECR	Initialized	—	—	—	—	—	—	—	Initialized	
ABRKCR	Initialized	—	—	—	—	—	—	—	Initialized	INT
BARA	Initialized	—	—	—	—	—	—	—	Initialized	
BARB	Initialized	—	—	—	—	—	—	—	Initialized	
BARC	Initialized	—	—	—	—	—	—	—	Initialized	
IER16	Initialized	—	—	—	—	—	—	—	Initialized	
ISR16	Initialized	—	—	—	—	—	—	—	Initialized	
ISCR16H	Initialized	—	—	—	—	—	—	—	Initialized	
ISCR16L	Initialized	—	—	—	—	—	—	—	Initialized	
ISSR16	Initialized	—	—	—	—	—	—	—	Initialized	
ISSR	Initialized	—	—	—	—	—	—	—	Initialized	
PTCNT0	Initialized	—	—	—	—	—	—	—	Initialized	PORT
BCR2	Initialized	—	—	—	—	—	—	—	Initialized	BSC
WSCR2	Initialized	—	—	—	—	—	—	—	Initialized	
PCSR	Initialized	—	Initialized	—	Initialized	Initialized	Initialized	Initialized	Initialized	PWM
SYSCR2	Initialized	—	—	—	—	—	—	—	Initialized	SYSTEM
SBYCR	Initialized	—	—	—	—	—	—	—	Initialized	
LPWRCR	Initialized	—	—	—	—	—	—	—	Initialized	
MSTPCR_H	Initialized	—	—	—	—	—	—	—	Initialized	
MSTPCR_L	Initialized	—	—	—	—	—	—	—	Initialized	
SMR_1	Initialized	—	—	—	—	—	—	—	Initialized	SCI_1
ICCR_1	Initialized	—	—	—	—	—	—	—	Initialized	IC_1

Register Abbrevia- tion	Reset	High-Speed/ Medium-					Module Stop	Software Standby	Hardware Standby	Module
		Speed	Watch	Sleep	Sub-Active	Sub-Sleep				
BRR_1	Initialized	—	—	—	—	—	—	—	Initialized	SCI_1
ISCR_1	Initialized	—	—	—	—	—	—	—	Initialized	IIC_1
SCR_1	Initialized	—	—	—	—	—	—	—	Initialized	SCI_1
TDR_1	Initialized	—	Initialized	—	Initialized	Initialized	Initialized	Initialized	Initialized	
SSR_1	Initialized	—	Initialized	—	Initialized	Initialized	Initialized	Initialized	Initialized	
RDR_1	Initialized	—	Initialized	—	Initialized	Initialized	Initialized	Initialized	Initialized	
SCMR_1	Initialized	—	—	—	—	—	—	—	Initialized	
ICDR_1	—	—	—	—	—	—	—	—	—	IIC_1
SARX_1	Initialized	—	—	—	—	—	—	—	Initialized	
ICMR_1	Initialized	—	—	—	—	—	—	—	Initialized	
SAR_1	Initialized	—	—	—	—	—	—	—	Initialized	
TIER	Initialized	—	—	—	—	—	—	—	Initialized	FRT
TCSR	Initialized	—	—	—	—	—	—	—	Initialized	
FRC	Initialized	—	—	—	—	—	—	—	Initialized	
OCRA	Initialized	—	—	—	—	—	—	—	Initialized	
OCRB	Initialized	—	—	—	—	—	—	—	Initialized	
TCR	Initialized	—	—	—	—	—	—	—	Initialized	
TOCR	Initialized	—	—	—	—	—	—	—	Initialized	
ICRA	Initialized	—	—	—	—	—	—	—	Initialized	
OCRAR	Initialized	—	—	—	—	—	—	—	Initialized	
ICRB	Initialized	—	—	—	—	—	—	—	Initialized	
OCRAF	Initialized	—	—	—	—	—	—	—	Initialized	
ICRC	Initialized	—	—	—	—	—	—	—	Initialized	
OCRDM	Initialized	—	—	—	—	—	—	—	Initialized	
ICRD	Initialized	—	—	—	—	—	—	—	Initialized	
SMR_2	Initialized	—	—	—	—	—	—	—	Initialized	SCI_2
DACR_0	Initialized	—	Initialized	—	Initialized	Initialized	Initialized	Initialized	Initialized	PWMX_0
DADRA_0	Initialized	—	Initialized	—	Initialized	Initialized	Initialized	Initialized	Initialized	
BRR_2	Initialized	—	—	—	—	—	—	—	Initialized	SCI_2
SCR_2	Initialized	—	—	—	—	—	—	—	Initialized	
TDR_2	Initialized	—	Initialized	—	Initialized	Initialized	Initialized	Initialized	Initialized	
SSR_2	Initialized	—	Initialized	—	Initialized	Initialized	Initialized	Initialized	Initialized	
RDR_2	Initialized	—	Initialized	—	Initialized	Initialized	Initialized	Initialized	Initialized	

Register Abbrevia- tion	Reset	High-Speed/ Medium-					Module Stop	Software Standby	Hardware Standby	Module
		Speed	Watch	Sleep	Sub-Active	Sub-Sleep				
SCMR_2	Initialized	—	—	—	—	—	—	—	Initialized	SCI_2
DADRB_0	Initialized	—	Initialized	—	Initialized	Initialized	Initialized	Initialized	Initialized	PWMX_0
DACNT_0	Initialized	—	Initialized	—	Initialized	Initialized	Initialized	Initialized	Initialized	
TCSR_0	Initialized	—	—	—	—	—	—	—	Initialized	WDT_0
TCNT_0	Initialized	—	—	—	—	—	—	—	Initialized	
PAODR	Initialized	—	—	—	—	—	—	—	Initialized	PORT
PAPIN	—	—	—	—	—	—	—	—	—	
PADDR	Initialized	—	—	—	—	—	—	—	Initialized	
P1PCR	Initialized	—	—	—	—	—	—	—	Initialized	
P2PCR	Initialized	—	—	—	—	—	—	—	Initialized	
P3PCR	Initialized	—	—	—	—	—	—	—	Initialized	
P1DDR	Initialized	—	—	—	—	—	—	—	Initialized	
P2DDR	Initialized	—	—	—	—	—	—	—	Initialized	
P1DR	Initialized	—	—	—	—	—	—	—	Initialized	
P2DR	Initialized	—	—	—	—	—	—	—	Initialized	
P3DDR	Initialized	—	—	—	—	—	—	—	Initialized	
P4DDR	Initialized	—	—	—	—	—	—	—	Initialized	
P3DR	Initialized	—	—	—	—	—	—	—	Initialized	
P4DR	Initialized	—	—	—	—	—	—	—	Initialized	
P5DDR	Initialized	—	—	—	—	—	—	—	Initialized	
P6DDR	Initialized	—	—	—	—	—	—	—	Initialized	
P5DR	Initialized	—	—	—	—	—	—	—	Initialized	
P6DR	Initialized	—	—	—	—	—	—	—	Initialized	
PBODR	Initialized	—	—	—	—	—	—	—	Initialized	
PBPIN	—	—	—	—	—	—	—	—	—	
P8DDR	Initialized	—	—	—	—	—	—	—	Initialized	
P7PIN	—	—	—	—	—	—	—	—	—	
PBDDR	Initialized	—	—	—	—	—	—	—	Initialized	
P8DR	Initialized	—	—	—	—	—	—	—	Initialized	
P9DDR	Initialized	—	—	—	—	—	—	—	Initialized	
P9DR	Initialized	—	—	—	—	—	—	—	Initialized	
IER	Initialized	—	—	—	—	—	—	—	Initialized	INT
STCR	Initialized	—	—	—	—	—	—	—	Initialized	SYSTEM

Register Abbrevia- tion	Reset	High-Speed/ Medium-					Module Stop	Software Standby	Hardware Standby	Module
		Speed	Watch	Sleep	Sub-Active	Sub-Sleep				
SYSCR	Initialized	—	—	—	—	—	—	—	Initialized	SYSTEM
MDCR	Initialized	—	—	—	—	—	—	—	Initialized	
BCR	Initialized	—	—	—	—	—	—	—	Initialized	BSC
WSCR	Initialized	—	—	—	—	—	—	—	Initialized	
TCR_0	Initialized	—	—	—	—	—	—	—	Initialized	TMR_0,
TCR_1	Initialized	—	—	—	—	—	—	—	Initialized	TMR_1
TCSR_0	Initialized	—	—	—	—	—	—	—	Initialized	
TCSR_1	Initialized	—	—	—	—	—	—	—	Initialized	
TCORA_0	Initialized	—	—	—	—	—	—	—	Initialized	
TCORA_1	Initialized	—	—	—	—	—	—	—	Initialized	
TCORB_0	Initialized	—	—	—	—	—	—	—	Initialized	
TCORB_1	Initialized	—	—	—	—	—	—	—	Initialized	
TCNT_0	Initialized	—	—	—	—	—	—	—	Initialized	
TCNT_1	Initialized	—	—	—	—	—	—	—	Initialized	
PWOERB	Initialized	—	Initialized	—	Initialized	Initialized	Initialized	Initialized	Initialized	PWM
PWOERA	Initialized	—	Initialized	—	Initialized	Initialized	Initialized	Initialized	Initialized	
PWDPRB	Initialized	—	Initialized	—	Initialized	Initialized	Initialized	Initialized	Initialized	
PWDpra	Initialized	—	Initialized	—	Initialized	Initialized	Initialized	Initialized	Initialized	
PWSL	Initialized	—	Initialized	—	Initialized	Initialized	Initialized	Initialized	Initialized	
PWDR15 to 0	Initialized	—	Initialized	—	Initialized	Initialized	Initialized	Initialized	Initialized	
SMR_0	Initialized	—	—	—	—	—	—	—	Initialized	SCI_0
ICCR_0	Initialized	—	—	—	—	—	—	—	Initialized	IIC_0
BRR_0	Initialized	—	—	—	—	—	—	—	Initialized	SCI_0
ICSR_0	Initialized	—	—	—	—	—	—	—	Initialized	IIC_0
SCR_0	Initialized	—	—	—	—	—	—	—	Initialized	SCI_0
TDR_0	Initialized	—	Initialized	—	Initialized	Initialized	Initialized	Initialized	Initialized	
SSR_0	Initialized	—	Initialized	—	Initialized	Initialized	Initialized	Initialized	Initialized	
RDR_0	Initialized	—	Initialized	—	Initialized	Initialized	Initialized	Initialized	Initialized	
SCMR_0	Initialized	—	—	—	—	—	—	—	Initialized	
ICDR_0	—	—	—	—	—	—	—	—	—	IIC_0
SARX_0	Initialized	—	—	—	—	—	—	—	Initialized	
ICMR_0	Initialized	—	—	—	—	—	—	—	Initialized	
SAR_0	Initialized	—	—	—	—	—	—	—	Initialized	
ADDRAH	Initialized	—	Initialized	—	Initialized	Initialized	Initialized	Initialized	Initialized	A/D
ADDRAL	Initialized	—	Initialized	—	Initialized	Initialized	Initialized	Initialized	Initialized	converter

Register Abbreviation	Reset	High-Speed/ Medium-Speed	Watch	Sleep	Sub-Active	Sub-Sleep	Module Stop	Software Standby	Hardware Standby	Module
		Speed								
ADDRBH	Initialized	—	Initialized	—	Initialized	Initialized	Initialized	Initialized	Initialized	A/D converter
ADDRBL	Initialized	—	Initialized	—	Initialized	Initialized	Initialized	Initialized	Initialized	
ADDRCH	Initialized	—	Initialized	—	Initialized	Initialized	Initialized	Initialized	Initialized	
ADDRCL	Initialized	—	Initialized	—	Initialized	Initialized	Initialized	Initialized	Initialized	
ADDRDH	Initialized	—	Initialized	—	Initialized	Initialized	Initialized	Initialized	Initialized	
ADDRDL	Initialized	—	Initialized	—	Initialized	Initialized	Initialized	Initialized	Initialized	
ADCSR	Initialized	—	Initialized	—	Initialized	Initialized	Initialized	Initialized	Initialized	
ADCR	Initialized	—	Initialized	—	Initialized	Initialized	Initialized	Initialized	Initialized	
TCSR_1	Initialized	—	—	—	—	—	—	—	Initialized	WDT_1
TCNT_1	Initialized	—	—	—	—	—	—	—	Initialized	
TCR_X	Initialized	—	—	—	—	—	—	—	Initialized	TMR_X
TCY_Y	Initialized	—	—	—	—	—	—	—	Initialized	TMR_Y
KMIMR6	Initialized	—	—	—	—	—	—	—	Initialized	INT
TCSR_X	Initialized	—	—	—	—	—	—	—	Initialized	TMR_X
TCSR_Y	Initialized	—	—	—	—	—	—	—	Initialized	TMR_Y
KMPCR6	Initialized	—	—	—	—	—	—	—	Initialized	PORT
TICRR	Initialized	—	—	—	—	—	—	—	Initialized	TMR_X
TCORA_Y	Initialized	—	—	—	—	—	—	—	Initialized	TMR_Y
KMIMRA	Initialized	—	—	—	—	—	—	—	Initialized	INT
TICRF	Initialized	—	—	—	—	—	—	—	Initialized	TMR_X
TCORB_Y	Initialized	—	—	—	—	—	—	—	Initialized	TMR_Y
WUEMR3	Initialized	—	—	—	—	—	—	—	Initialized	INT
TCNT_X	Initialized	—	—	—	—	—	—	—	Initialized	TMR_X
TCNT_Y	Initialized	—	—	—	—	—	—	—	Initialized	TMR_Y
TCORC	Initialized	—	—	—	—	—	—	—	Initialized	TMR_X
TISR	Initialized	—	—	—	—	—	—	—	Initialized	TMR_Y
TCORA_X	Initialized	—	—	—	—	—	—	—	Initialized	TMR_X
TCORB_X	Initialized	—	—	—	—	—	—	—	Initialized	
DADR0	Initialized	—	—	—	—	—	—	—	Initialized	D/A converter
DADR1	Initialized	—	—	—	—	—	—	—	Initialized	
DACR	Initialized	—	—	—	—	—	—	—	Initialized	
TCONRI	Initialized	—	—	—	—	—	—	—	Initialized	TMR
TCONRS	Initialized	—	—	—	—	—	—	—	Initialized	

Section 25 Electrical Characteristics

25.1 Absolute Maximum Ratings

Table 25.1 lists the absolute maximum ratings.

Table 25.1 Absolute Maximum Ratings

Item	Symbol	Value	Unit
Power supply voltage*	VCC	-0.3 to +4.3	V
Input voltage (except port 7, 8, C0 to C5, D6, and D7)	V _{in}	-0.3 to VCC +0.3	
Input voltage (port 7)	V _{in}	-0.3 to AVCC +0.3	
Input voltage (port 8, C0 to C5, D6, and D7)	V _{in}	-0.3 to +7.0	
Reference power supply voltage	AVref	-0.3 to AVCC +0.3	
Analog power supply voltage	AVCC	-0.3 to +4.3	
Analog input voltage	V _{AN}	-0.3 to AVCC +0.3	
Operating temperature	T _{opr}	Regular specifications: -20 to +75	°C
		Wide-range specifications: -40 to +85	
Operating temperature (when flash memory is programmed or erased)	T _{opr}	0 to +75	
Storage temperature	T _{stg}	-55 to +125	

Caution: Permanent damage to this LSI may result if absolute maximum ratings are exceeded.

Note: * Voltage applied to the VCC pin.

Make sure power is not applied to the VCL pin.

25.2 DC Characteristics

Table 25.2 lists the DC characteristics. Table 25.3 lists the permissible output currents. Table 25.4 lists the bus drive characteristics.

Table 25.2 DC Characteristics (1)

Conditions: $V_{CC} = 3.0\text{ V to }3.6\text{ V}$, $AV_{CC}^{*1} = 3.0\text{ V to }3.6\text{ V}$,
 $AV_{ref}^{*1} = 3.0\text{ V to }AV_{CC}$, $V_{SS} = AV_{SS}^{*1} = 0\text{ V}$

Item	Symbol	Min.	Typ.	Max.	Test Unit	Conditions
Schmitt trigger input voltage	P67 to P60* ² , EVENT15 to EVENT0, (Ex)TMIY, (Ex)TMIX, (Ex)TMI1, (Ex)TMI0, (Ex)IRQ15 to (Ex)IRQ2, IRQ1, IRQ0, KIN15 to KIN0, WUE15 to WUE8, ETRST, XTAL, EXCL, ADTRG	(1) V_T^-	$V_{CC} \times 0.2$	—	—	V
		V_T^+	—	—	$V_{CC} \times 0.7$	
		$V_T^+ - V_T^-$	$V_{CC} \times 0.05$	—	—	
		SCL5 to SCL0, SDA5 to SDA0				
	V_T^-	$V_{CC} \times 0.3$	—	—		
	V_T^+	—	—	$V_{CC} \times 0.7$		
	$V_T^+ - V_T^-$	$V_{CC} \times 0.05$	—	—		
Input high voltage	RES, STBY, NMI, FWE, MD2, MD1 MD0 EXTAL Port 7 SCL5 to SCL0, SDA5 to SDA0 CLKRUN, GA20, PME, LSMI, LSCI, SERIRQ, LAD3 to LAD0, LPCPD, LCLK, LRESET, LFRAME	(2) V_{IH}	$V_{CC} \times 0.9$	—	$V_{CC} + 0.3$	
			$V_{CC} \times 0.7$	—	$V_{CC} + 0.3$	
			2.2	—	$AV_{CC} + 0.3$	
			—	—	5.5	
			$V_{CC} \times 0.5$	—	$V_{CC} + 0.3$	
			2.2	—	$V_{CC} + 0.3$	
Input low voltage	RES, STBY, NMI, FWE, MD2, MD1, MD0 EXTAL Port 7 CLKRUN, GA20, PME, LSMI, LSCI, SERIRQ, LAD3 to LAD0, LPCPD, LCLK, LRESET, LFRAME	(3) V_{IL}	-0.3	—	$V_{CC} \times 0.1$	
			-0.3	—	$V_{CC} \times 0.1$	$f > 25\text{ MHz}$
			-0.3	—	$V_{CC} \times 0.2$	$f \leq 25\text{ MHz}$
			-0.3	—	$AV_{CC} \times 0.2$	
			-0.3	—	$V_{CC} \times 0.3$	
			-0.3	—	$V_{CC} \times 0.2$	
	Input pins other than (1) and (3) above	-0.3	—	$V_{CC} \times 0.2$		

Item	Symbol	Min.	Typ.	Max.	Test		
					Unit	Conditions	
Output high voltage	SCL5 to SCL0, SDA5 to SDA0* ³	(4) V_{OH}	—	—	—		
	Port 8, C0 to C5, D6, D7, SCK2 to SCK0* ⁴		0.5	—	—		$I_{OH} = -200 \mu A$
	CLKRUN, GA20, PME, LSMI, LSCI, SERIRQ, LAD3 to LAD0		$VCC \times 0.9$	—	—		$I_{OH} = -0.5 mA$
	Output pins other than (4) above		$VCC - 0.5$	—	—		$I_{OH} = -200 \mu A$
Output low voltage	SCL5 to SCL0, SDA5 to SDA0* ³	(5) V_{OL}	—	—	0.5		$I_{OL} = 8 mA$
	Port 8, C0 to C5, D6, D7, SCK2 to SCK0* ⁴		—	—	0.4		$I_{OL} = 3 mA$
	CLKRUN, GA20, PME, LSMI, LSCI, SERIRQ, LAD3 to LAD0		—	—	$VCC \times 0.1$		$I_{OL} = 1.5 mA$
	Output pins other than (5) above		—	—	0.4		$I_{OL} = 1.6 mA$
	Ports 1, 2, and 3		—	—	1.0		$I_{OL} = 5 mA$

Table 25.2 DC Characteristics (2)

Conditions: $VCC = 3.0 V$ to $3.6 V$, $AVCC^{*1} = 3.0 V$ to $3.6 V$,
 $AVref^{*1} = 3.0 V$ to $AVCC$, $VSS = AVSS^{*1} = 0 V$

Item	Symbol	Min.	Typ.	Max.	Unit	Test		
						Unit	Conditions	
Input leakage current	RES, STBY, NMI, FWE, MD2, MD1, MD0, PFSEL	$ I_{in} $	—	—	1.0	μA	$V_{IN} = 0.5$ to $VCC - 0.5 V$	
	Port 7		—	—	1.0		$V_{IN} = 0.5$ to $AVCC - 0.5 V$	
Three-state leakage current (off state)	Ports 1 to 6 Ports 8 to F	$ I_{TSI} $	—	—	1.0		$V_{IN} = 0.5$ to $VCC - 0.5 V$	
Input pull-up MOS current	Ports 1 to 3	$-I_p$	5	—	150		$V_{IN} = 0 V$	
	Ports 6 (P6PUE=0), A, D		30	—	300			
	Port 6 (P6PUE=1)		3	—	100			
Current consumption* ⁵	Normal operation	I_{CC}	—	43	55	mA	$f = 33 MHz$, high-speed mode, All modules operating	
	Sleep mode		—	30	40		$f = 33 MHz$	
	Standby mode* ⁶			—	38	90	μA	$Ta \leq 50 ^\circ C$
				—	—	120		$50 ^\circ C < Ta$

Item		Symbol	Min.	Typ.	Max.	Unit	Test
							Conditions
Analog power supply current	During A/D, D/A conversion	AI_{cc}	—	1.0	2.0	mA	
	A/D, D/A conversion standby		—	2.5	5.0	μ A	
Reference power supply current	During A/D conversion	AI_{ref}	—	0.1	1.0	mA	
	During A/D, D/A conversion		—	0.5	5.0		
	A/D, D/A conversion standby		—	0.5	5.0	μ A	
Input capacitance	All input pin	C_{in}	—	—	10	pF	$V_{in} = 0$ V, $f = 1$ MHz, $T_a = 25$ °C
RAM standby voltage		V_{RAM}	3.0	—	—	V	
VCC start voltage		VCC_{START}	—	0	0.8	V	
VCC rising edge		SVCC	—	—	20	ms/V	

Notes: 1. Do not leave the AVCC, AVref, and AVSS pins open even if the A/D converter or D/A converter is not used.

Even if the A/D converter or D/A converter is not used, apply a value in the range from 3.0 V to 3.6 V to the AVCC and AVref pins by connecting them to the power supply (VCC). The relationship between these two pins should be $AVref \leq AVCC$.

2. When noise cancel has been enabled.
3. An external pull-up resistor is necessary to provide high-level output from SCL5 to SCL0 and SDA5 to SDA0 (ICE bit in ICCR is 1).
4. Port 8, C0 to C5, D6, and D7 are NMOS push-pull outputs.
Port 8, C0 to C5, D6, D7, and SCK0 to SCK2 (ICE bit in ICCR = 0) high levels are driven by NMOS. An external pull-up resistor is necessary to provide high-level output from these pins when they are used as an output.
5. Current consumption values are for $V_{IH} \text{ min} = VCC - 0.2$ V and $V_{IL} \text{ max} = 0.2$ V with all output pins unloaded and the on-chip pull-up MOSs in the off state.
6. When $VCC = 3.0$ V, $V_{IH} \text{ min} = VCC - 0.2$ V, and $V_{IL} \text{ max} = 0.2$ V.

Table 25.3 Permissible Output Currents

Conditions: $V_{CC} = 3.0\text{ V to }3.6\text{ V}$, $AV_{CC} = 3.0\text{ V to }3.6\text{ V}$,
 $AV_{ref} = 3.0\text{ V to }AV_{CC}$, $V_{SS} = AV_{SS} = 0\text{ V}$

Item		Symbol	Min.	Typ.	Max.	Unit
Permissible output low current (per pin)	SCL5 to SCL0, SDA5 to SDA0	I_{OL}	—	—	10	mA
	Ports 1, 2, and 3		—	—	5	
	Other output pins		—	—	1.6	
Permissible output low current (total)	Total of ports 1, 2, and 3	ΣI_{OL}	—	—	80	
	Total of all output pins, including the above		—	—	90	
Permissible output high current (per pin)	All output pins	$-I_{OH}$	—	—	2	
Permissible output high current (total)	Total of all output pins	$\Sigma -I_{OH}$	—	—	60	

- Notes:
1. To protect LSI reliability, do not exceed the output current values in table 25.3.
 2. When driving a Darlington transistor or LED, always insert a current-limiting resistor in the output line, as show in figures 25.1 and 25.2.

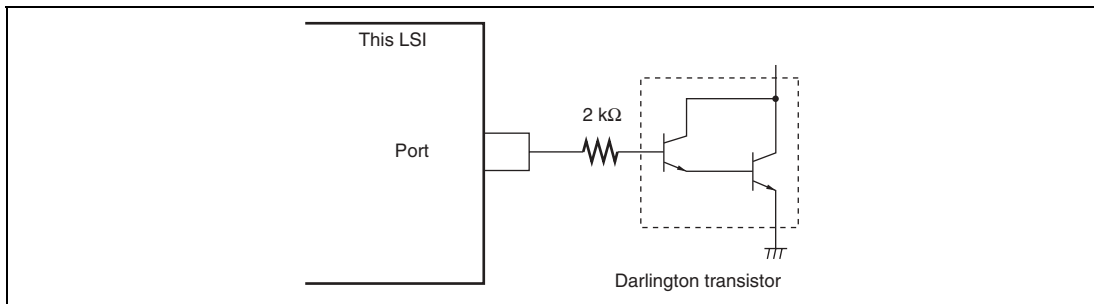

Figure 25.1 Darlington Transistor Drive Circuit (Example)

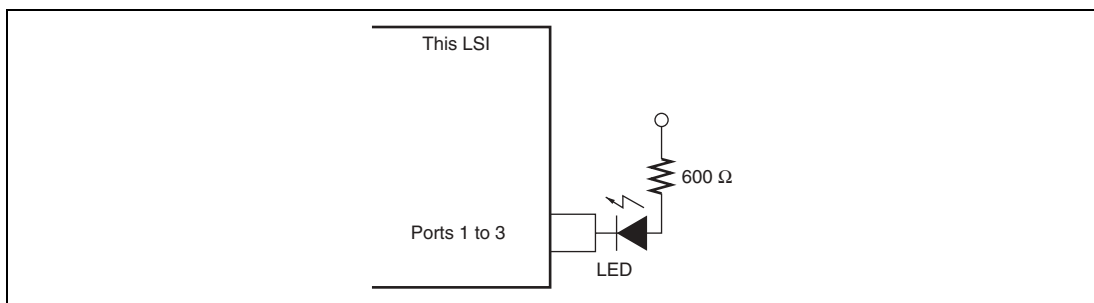

Figure 25.2 LED Drive Circuit (Example)

25.3 AC Characteristics

Figure 25.3 shows the test conditions for the AC characteristics.

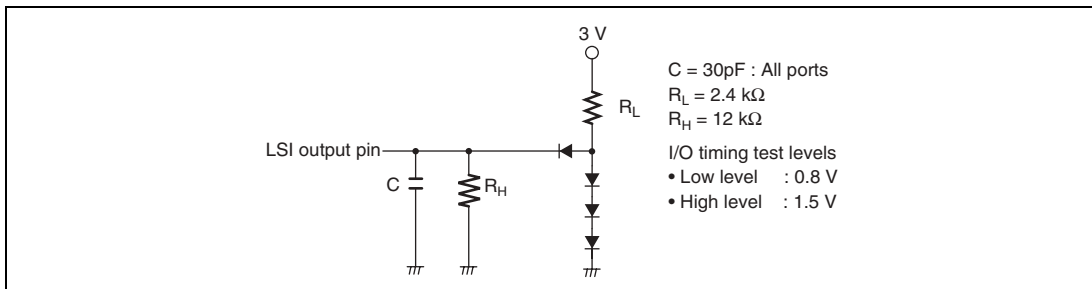

Figure 25.3 Output Load Circuit

25.3.1 Clock Timing

Table 25.4 shows the clock timing. The clock timing specified here covers clock output (ϕ) and clock pulse generator (crystal) and external clock input (EXTAL pin) oscillation stabilization times. For details of external clock input (EXTAL pin and EXCL pin) timing, see table 25.5 and 25.6.

Table 25.4 Clock Timing

Condition: VCC = 3.0 V to 3.6 V, VSS = 0 V, ϕ = 5 MHz to 33 MHz

Item	Symbol	Min.	Max.	Unit	Reference
Clock cycle time	t_{cyc}	30	200	ns	Figure 25.4
Clock high level pulse width	t_{CH}	10	—		
Clock low level pulse width	t_{CL}	10	—		
Clock rise time	t_{Cr}	—	5		
Clock fall time	t_{Cf}	—	5		
Reset oscillation stabilization (crystal)	t_{OSC1}	10	—	ms	Figure 25.5
Software standby oscillation stabilization time (crystal)	t_{OSC2}	8	—		Figure 25.6

Table 25.5 External Clock Input Conditions

Condition: VCC = 3.0 V to 3.6 V, VSS = 0 V, ϕ = 5 MHz to 33 MHz

Item	Symbol	Min.	Max.	Unit	Test Conditions
External clock input low level pulse width	t_{EXL}	10	—	ns	Figure 25.7
External clock input high level pulse width	t_{EXH}	10	—	ns	
External clock input rising time	t_{EXr}	—	5	ns	
External clock input falling time	t_{EXf}	—	5	ns	
Clock low level pulse width	t_{CL}	0.4	0.6	t_{cyc}	Figure 25.4
Clock high level pulse width	t_{CH}	0.4	0.6	t_{cyc}	
External clock output stabilization delay time	t_{DEXT}^*	500	—	μ s	Figure 25.8

Note: * t_{DEXT} includes a \overline{RES} pulse width (t_{RESW}).

Table 25.6 Subclock Input Conditions

Condition: VCC = 3.0 V to 3.6 V, VSS = 0 V, ϕ SUB = 32.768 kHz, 5 MHz to 33 MHz

Item	Symbol	Min.	Typ.	Max.	Unit	Measurement Condition
Subclock input low level pulse width	t_{EXCLL}	—	15.26	—	μ s	Figure 25.9
Subclock input high level pulse width	t_{EXCLH}	—	15.26	—	μ s	
Subclock input rising time	t_{EXCLr}	—	—	10	ns	
Subclock input falling time	t_{EXCLf}	—	—	10	ns	
Clock low level pulse width	t_{CL}	0.4	—	0.6	t_{cyc}	Figure 25.4
Clock high level pulse width	t_{CH}	0.4	—	0.6	t_{cyc}	

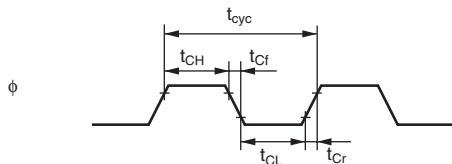

Figure 25.4 System Clock Timing

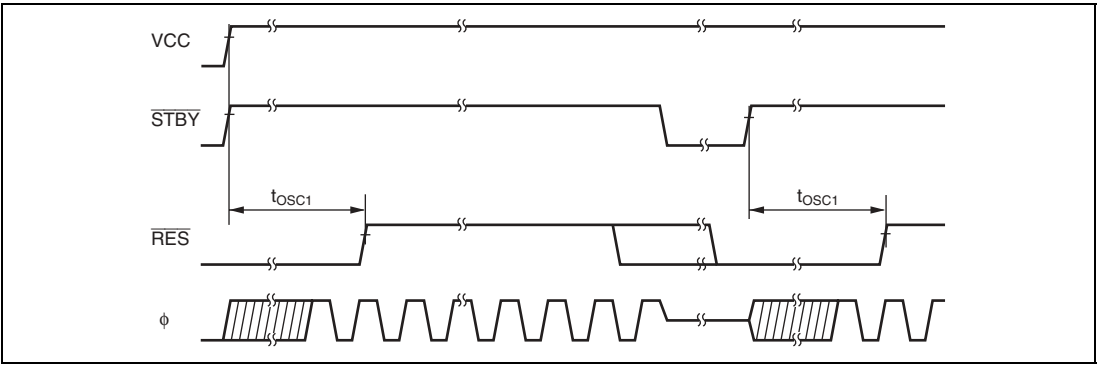

Figure 25.5 Oscillation Stabilization Timing

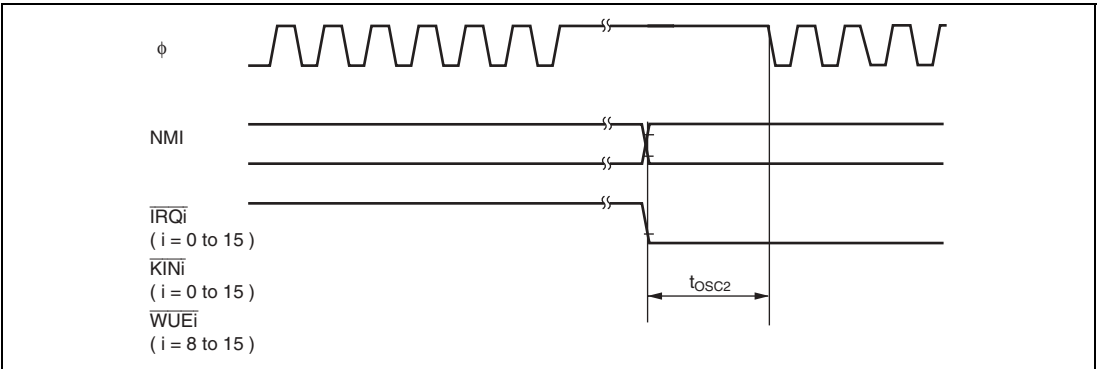

Figure 25.6 Oscillation Stabilization Timing (Exiting Software Standby Mode)

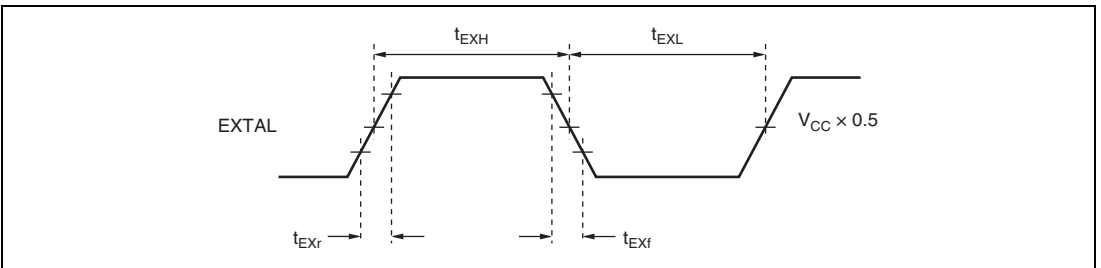
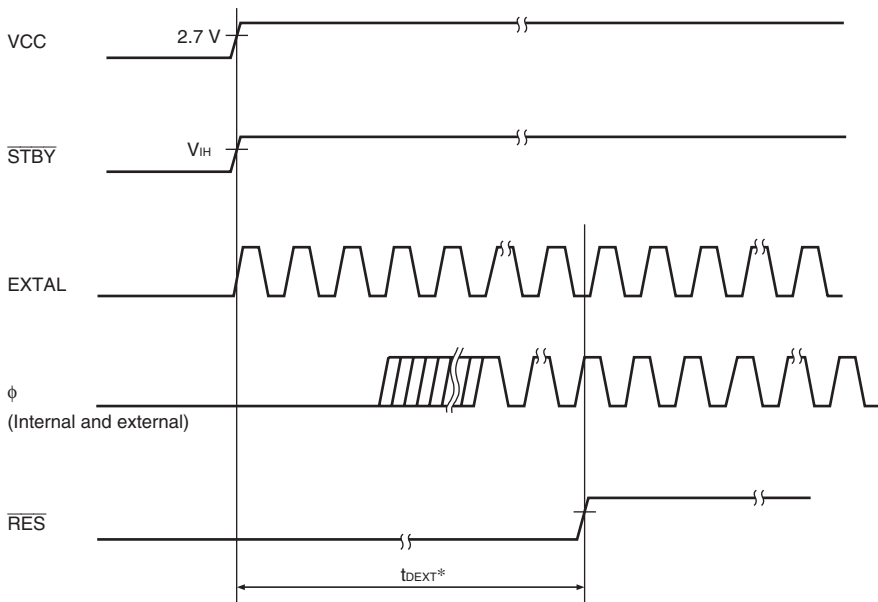

Figure 25.7 External Clock Input Timing



Note: The external clock output stabilization delay time (t_{DEXT}) includes a \overline{RES} pulse width (t_{RESW}).

Figure 25.8 Timing of External Clock Output Stabilization Delay Time

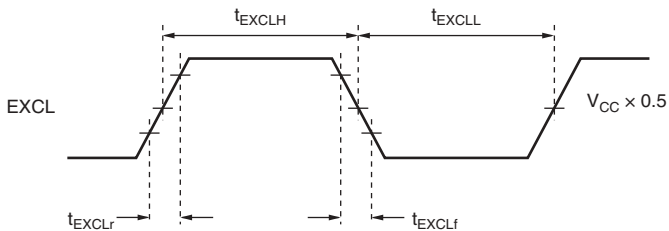

Figure 25.9 Subclock Input Timing

25.3.2 Control Signal Timing

Table 25.7 shows the control signal timing. Only external interrupts NMI, IRQ0 to IRQ15, KIN0 to KIN15, and WUE8 to WUE15 can be operated based on the subclock ($\phi_{SUB} = 32.768$ kHz).

Table 25.7 Control Signal Timing

Condition: VCC = 3.0 V to 3.6 V, VSS = 0 V, $\phi = 5$ MHz to 33 MHz

Item	Symbol	Min.	Max.	Unit	Test Conditions
\overline{RES} setup time	t_{RESS}	200	—	ns	Figure 25.10
\overline{RES} pulse width	t_{RESW}	20	—	t_{cyc}	
NMI setup time	t_{NMIS}	150	—	ns	Figure 25.11
NMI hold time	t_{NMIH}	10	—		
NMI pulse width (exiting software standby mode)	t_{NMIW}	200	—		
IRQ setup time (IRQ15 to IRQ0, KIN15 to KIN0, WUE15 to WUE8)	t_{IRQS}	150	—		
IRQ hold time (IRQ15 to IRQ0, KIN15 to KIN0, WUE15 to WUE8)	t_{IRQH}	10	—		
IRQ pulse width (IRQ15 to IRQ0, KIN15 to KIN0, WUE15 to WUE8) (exiting software standby mode)	t_{IRQW}	200	—		

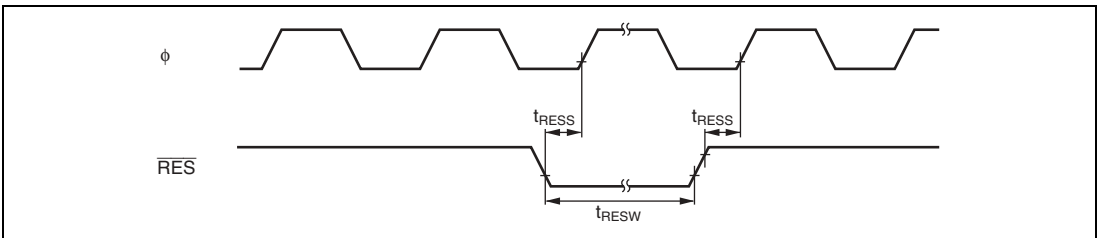

Figure 25.10 Reset Input Timing

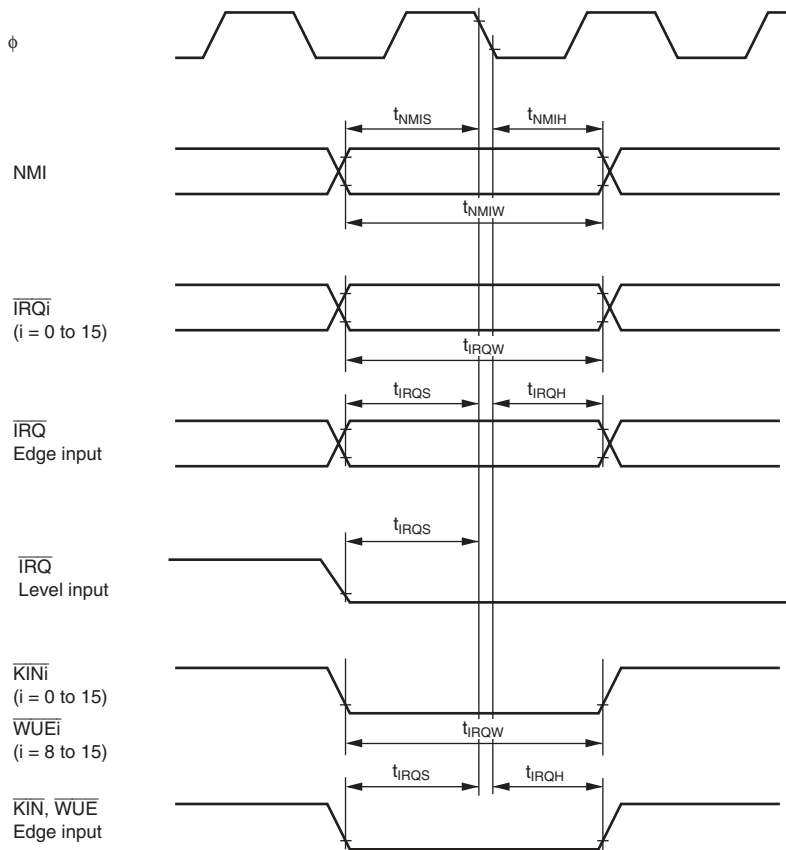

Figure 25.11 Interrupt Input Timing

25.3.3 Bus Timing

Table 25.8 shows the bus timing. In subclock ($\phi_{\text{SUB}} = 32.768 \text{ kHz}$) operation, external expansion mode operation cannot be guaranteed.

Table 25.8 Bus Timing

Condition: $V_{\text{CC}} = 3.0 \text{ V to } 3.6 \text{ V}$, $V_{\text{SS}} = 0 \text{ V}$, $\phi = 5 \text{ MHz to } 33 \text{ MHz}$

Item	Symbol	Min.	Max.	Unit	Test Conditions
Address delay time	t_{AD}	—	15	ns	Figures 25.12 to 25.16
Address setup time	t_{AS}	$0.5 \times t_{\text{cyc}} - 15$	—		
Address hold time	t_{AH}	$0.5 \times t_{\text{cyc}} - 10$	—		
$\overline{\text{CS}}$ delay time ($\overline{\text{IOS}}$, $\overline{\text{CS256}}$, $\overline{\text{CPCS1}}$)	t_{CSD}	—	15		
$\overline{\text{AS}}$ delay time	t_{ASD}	—	15		
$\overline{\text{RD}}$ delay time 1	t_{RSD1}	—	15		
$\overline{\text{RD}}$ delay time 2	t_{RSD2}	—	15		
Read data setup time	t_{RDS}	15	—		
Read data hold time	t_{RDH}	0	—		
Read data access time 1	t_{ACC1}	—	$1.0 \times t_{\text{cyc}} - 30$		
Read data access time 2	t_{ACC2}	—	$1.5 \times t_{\text{cyc}} - 25$		
Read data access time 3	t_{ACC3}	—	$2.0 \times t_{\text{cyc}} - 30$		
Read data access time 4	t_{ACC4}	—	$2.5 \times t_{\text{cyc}} - 25$		
Read data access time 5	t_{ACC5}	—	$3.0 \times t_{\text{cyc}} - 30$		
$\overline{\text{WR}}$ delay time 1	t_{WRD1}	—	15		
$\overline{\text{WR}}$ delay time 2	t_{WRD2}	—	15		
$\overline{\text{WR}}$ pulse width 1	t_{WSW1}	$1.0 \times t_{\text{cyc}} - 20$	—		
$\overline{\text{WR}}$ pulse width 2	t_{WSW2}	$1.5 \times t_{\text{cyc}} - 20$	—		
Write data delay time	t_{WDD}	—	25		
Write data setup time	t_{WDS}	0	—		
Write data hold time	t_{WDH}	$0.5 \times t_{\text{cyc}} - 5$	—		
$\overline{\text{WAIT}}$ setup time	t_{WTS}	25	—		
$\overline{\text{WAIT}}$ hold time	t_{WTH}	5	—		

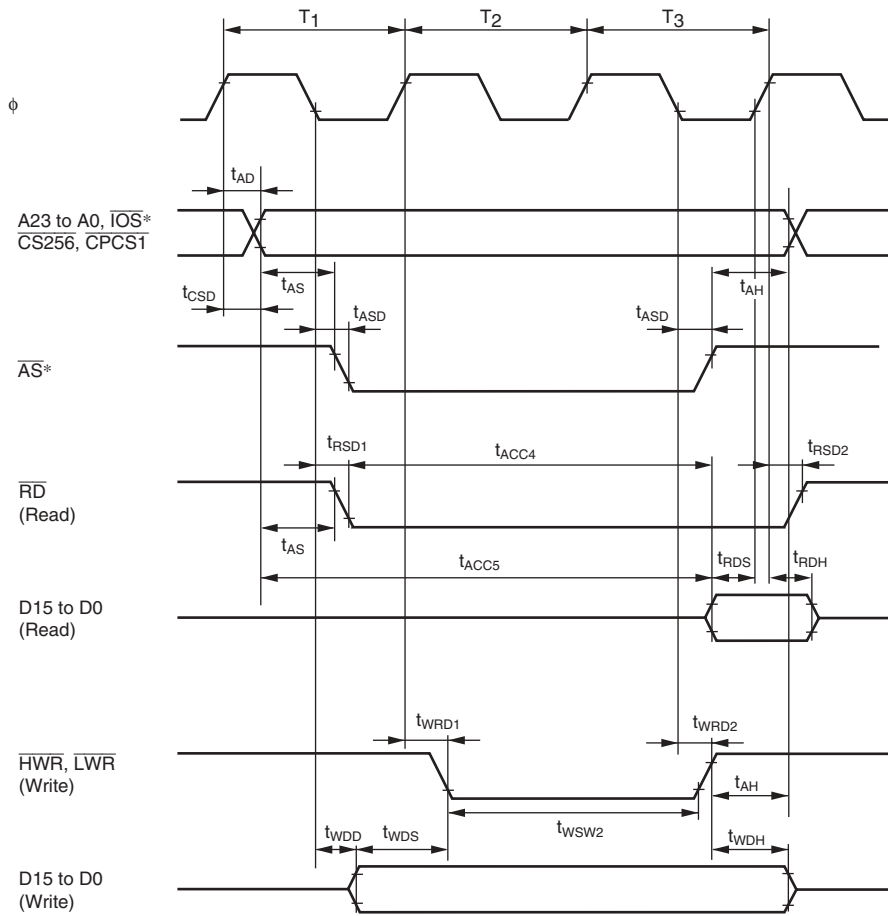

Note: * \overline{AS} is multiplexed with \overline{IOS} . Either the \overline{AS} or \overline{IOS} function can be selected by the IOSE bit of SYSCR.

Figure 25.13 Basic Bus Timing/3-State Access

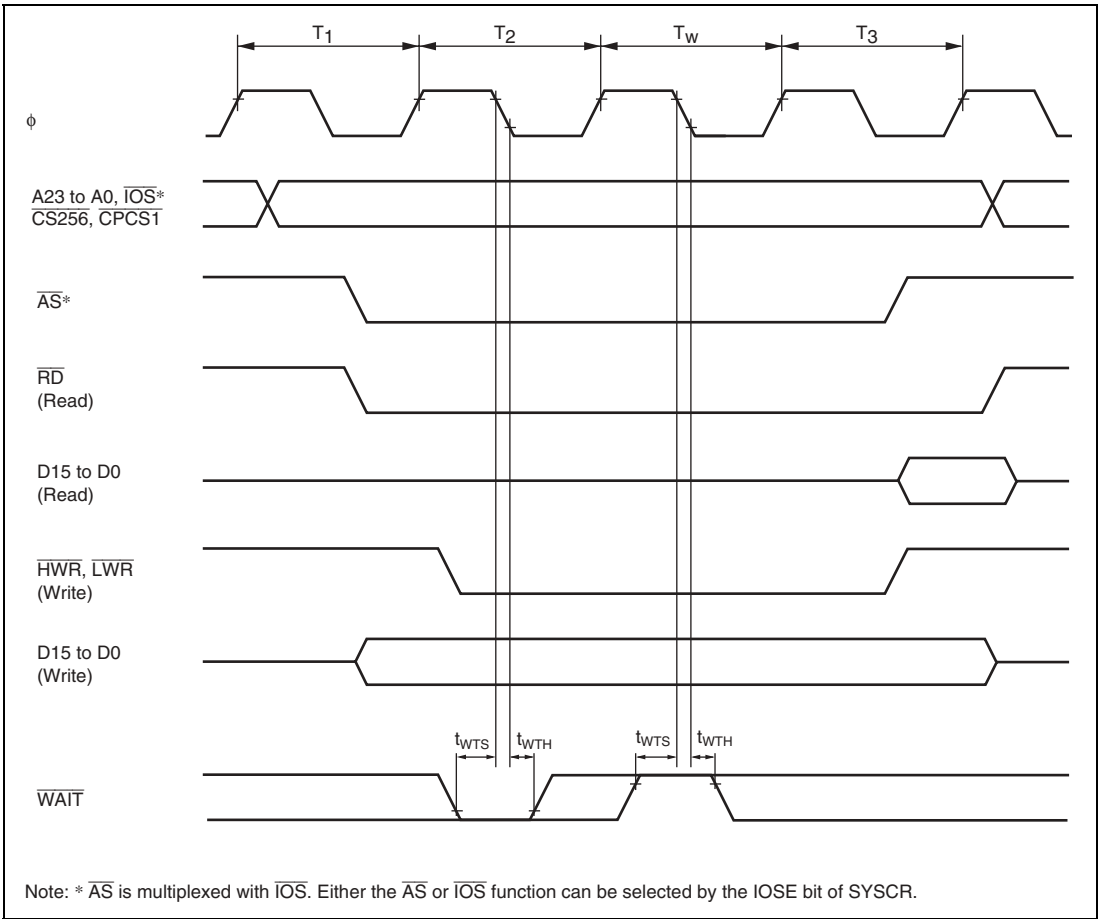

Figure 25.14 Basic Bus Timing/3-State Access with One Wait State

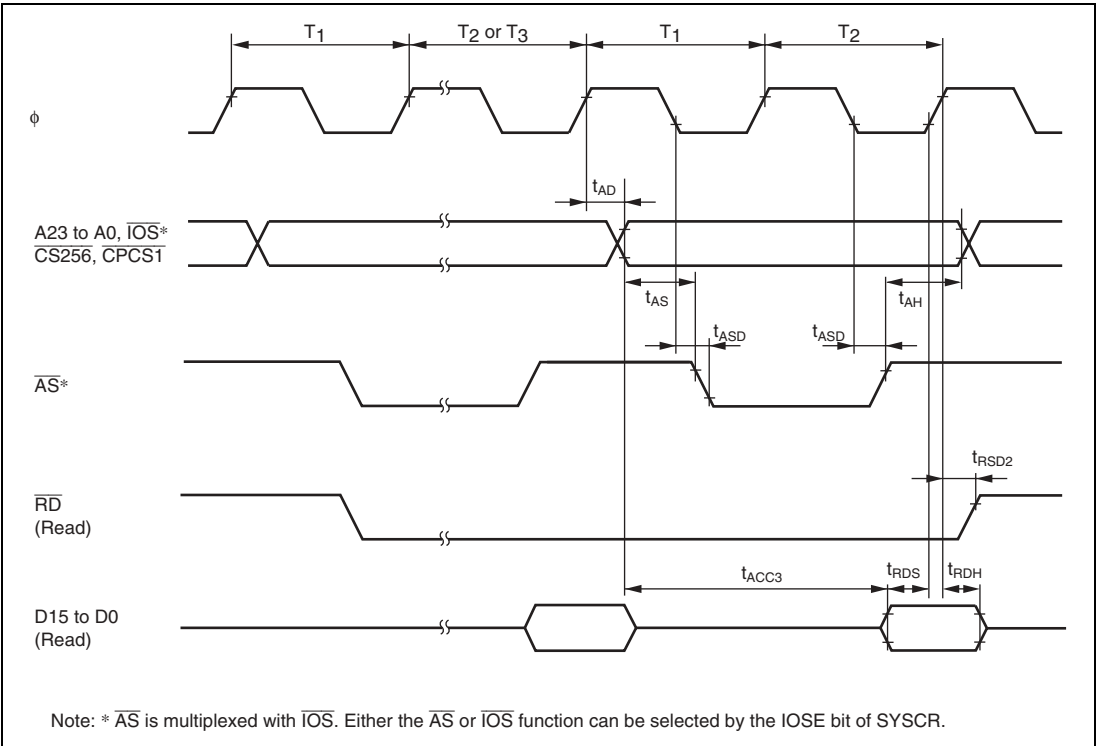
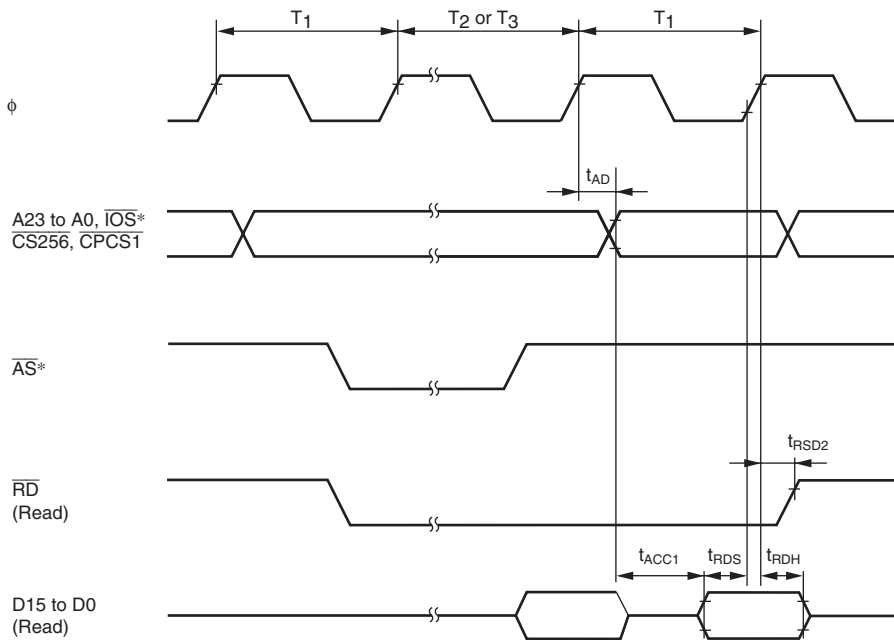

Figure 25.15 Burst ROM Access Timing/2-State Access



Note: * \overline{AS} is multiplexed with \overline{IOS} . Either the \overline{AS} or \overline{IOS} function can be selected by the IOSE bit of SYSCR.

Figure 25.16 Burst ROM Access Timing/1-State Access

25.3.4 Multiplex Bus Timing

Table 25.9 shows the Multiplex bus interface timing. In subclock ($\phi_{SUB} = 32.768$ kHz) operation, external expansion mode operation cannot be guaranteed.

Table 25.9 Multiplex Bus Timing

Condition: $V_{CC} = 3.0$ V to 3.6 V, $V_{SS} = 0$ V, $\phi = 5$ MHz to 33 MHz

Item	Symbol	Min..	Max.	Unit	Test Conditions
Address delay time	t_{AD}	—	15	ns	Figures 25.17,
Address setup time 2	t_{AS2}	$0.5 \times t_{cyc} - 15$	—		25.18
Address hold time 2	t_{AH2}	$1.0 \times t_{cyc} - 10$	—		
\overline{CS} delay time (\overline{IOS} , $CS256$, $CPCS1$)	t_{CSD}	—	15		
\overline{AH} delay time	t_{AHD}	—	15		
\overline{RD} delay time 1	t_{RSD1}	—	15		
\overline{RD} delay time 2	t_{RSD2}	—	15		
Read data setup time	t_{RDS}	15	—		
Read data hold time	t_{RDH}	0	—		
Read data access time 2	t_{ACC2}	—	$1.5 \times t_{cyc} - 25$		
Read data access time 4	t_{ACC4}	—	$2.5 \times t_{cyc} - 25$		
Read data access time 6	t_{ACC6}	—	$3.5 \times t_{cyc} - 25$		
Read data access time 7	t_{ACC7}	—	$4.5 \times t_{cyc} - 25$		
\overline{WR} delay time 1	t_{WRD1}	—	15		
\overline{WR} delay time 2	t_{WRD2}	—	15		
\overline{WR} pulse width time 1	t_{WSW1}	$1.0 \times t_{cyc} - 20$	—		
\overline{WR} pulse width time 2	t_{WSW2}	$1.5 \times t_{cyc} - 20$	—		
Write data delay time	t_{WDD}	—	25		
Write data setup time	t_{WDS}	0	—		
Write data hold time	t_{WDH}	$0.5 \times t_{cyc} - 5$	—		

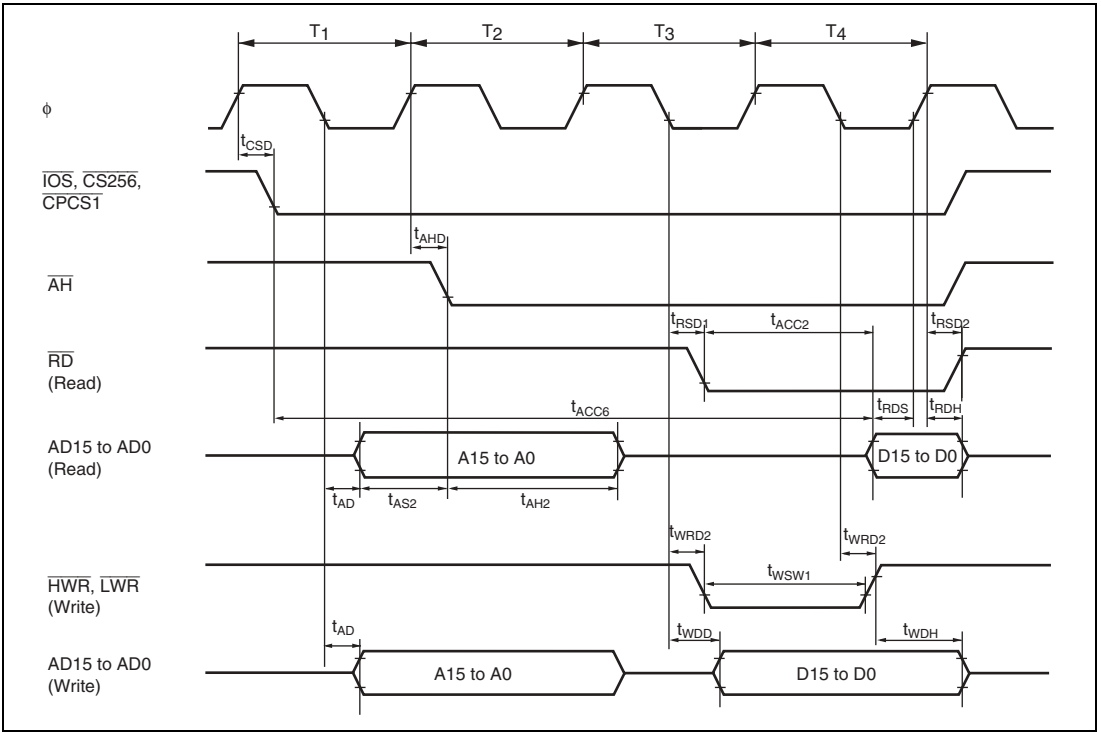

Figure 25.17 Multiplex Bus Timing/Data 2-State Access

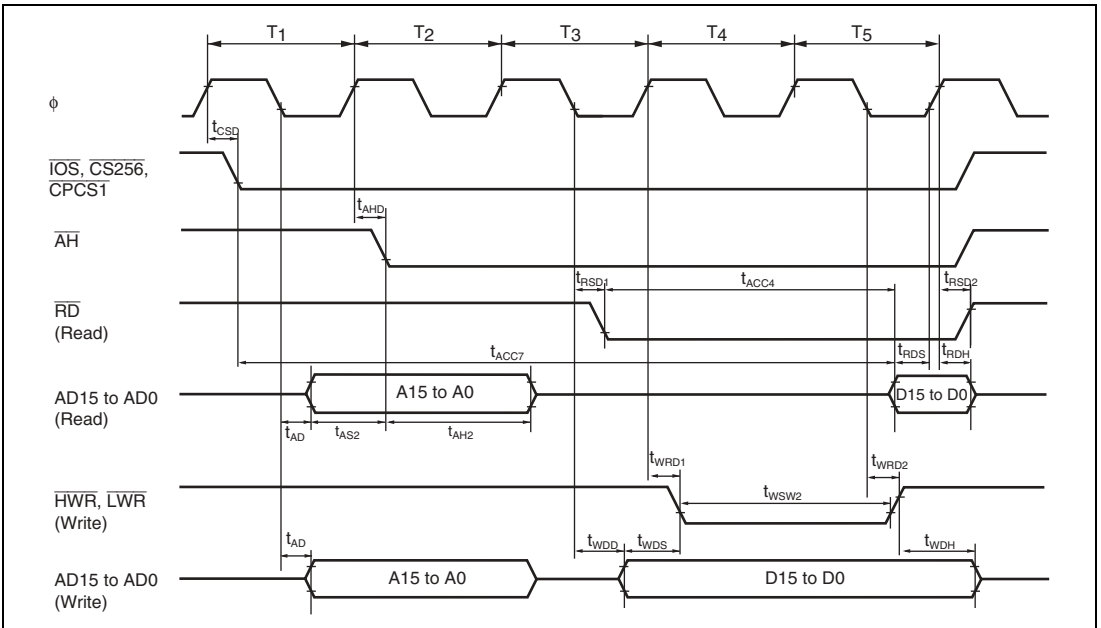

Figure 25.18 Multiplex Bus Timing/Data 3-State Access

25.3.5 Timing of On-Chip Peripheral Modules

Tables 25.10 to 25.13 show the on-chip peripheral module timing. The on-chip peripheral modules that can be operated by the subclock ($\phi_{\text{SUB}} = 32.768 \text{ kHz}$) are I/O ports, external interrupts (NMI, IRQ0 to IRQ15, KIN0 to KIN15, and WUE8 to WUE15), watchdog timer, and 8-bit timer (channels 0 and 1) only.

Table 25.10 Timing of On-Chip Peripheral Modules

 Condition: VCC = 3.0 V to 3.6 V, VSS = 0 V, ϕ SUB = 32.768 kHz*, ϕ = 5 MHz to 33 MHz

Item		Symbol	Min.	Max.	Unit	Test Conditions	
I/O ports	Output data delay time	t_{PWD}	—	30	ns	Figure 25.19	
	Input data setup time	t_{PRS}	20	—			
	Input data hold time	t_{PRH}	20	—			
FRT	Timer output delay time	t_{FTOD}	—	30	ns	Figure 25.20	
	Timer input setup time	t_{FTIS}	20	—			
	Timer clock input setup time	t_{FTCS}	20	—		Figure 25.21	
	Timer clock pulse width	Single edge	t_{FTCWH}	1.5	—		t_{cyc}
Both edges		t_{FTCWL}	2.5	—			
TMR	Timer output delay time	t_{TMOD}	—	30	ns	Figure 25.22	
	Timer reset input setup time	t_{TMRS}	20	—		Figure 25.24	
	Timer clock input setup time	t_{TMCS}	20	—		Figure 25.23	
	Timer clock pulse width	Single edge	t_{TMCWH}	1.5	—	t_{cyc}	
Both edges		t_{TMCWL}	2.5	—			
PWM, PWMX	Timer output delay time	t_{PWOD}	—	30	ns	Figure 25.25	
SCI	Input clock cycle	Asynchronous	t_{Scyc}	4	—	t_{cyc}	Figure 25.26
		Synchronous		6	—		
	Input clock pulse width	t_{SCKW}	0.4	0.6	t_{Scyc}		
	Input clock rise time	t_{SCKr}	—	1.5	t_{cyc}		
	Input clock fall time	t_{SCKf}	—	1.5			
	Transmit data delay time (synchronous)	t_{TXD}	—	30	ns	Figure 25.27	
	Receive data setup time (synchronous)	t_{RXS}	20	—			
Receive data hold time (synchronous)	t_{RXH}	20	—				
A/D converter	Trigger input setup time	t_{TRGS}	20	—	ns	Figure 25.28	
WDT	$\overline{RES0}$ output delay time	t_{RESD}	—	200	ns	Figure 25.29	
	$\overline{RES0}$ output pulse width	t_{RESOW}	132	—	t_{cyc}		

Note: * Only the peripheral modules that can be used in subclock operation.

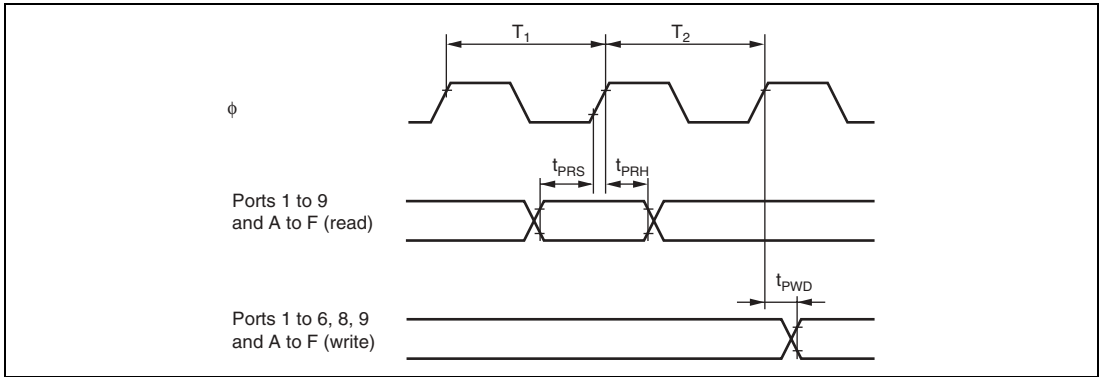

Figure 25.19 I/O Port Input/Output Timing

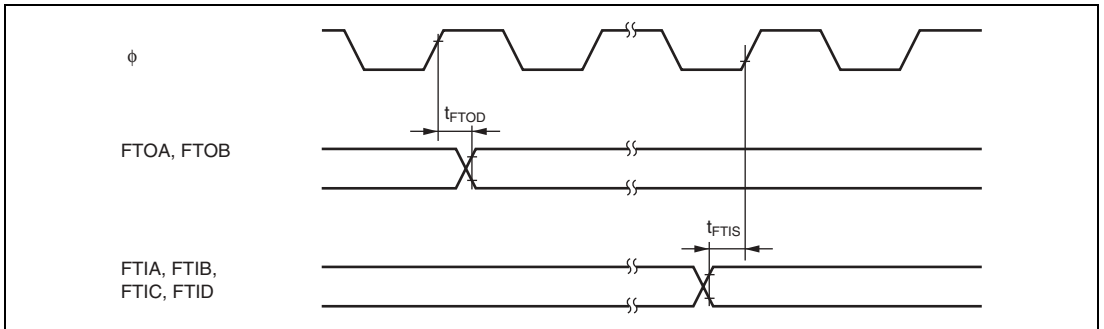

Figure 25.20 FRT Input/Output Timing

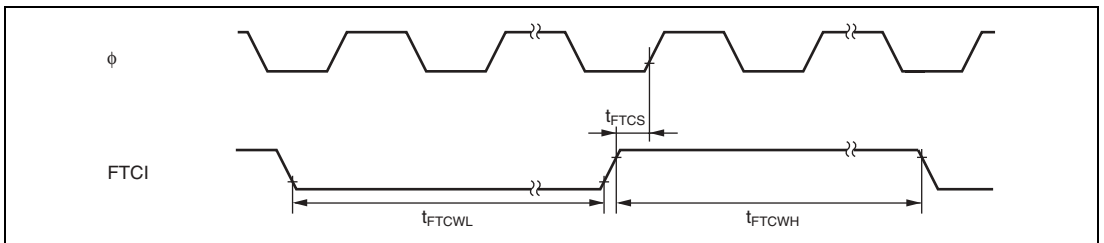

Figure 25.21 FRT Clock Input Timing

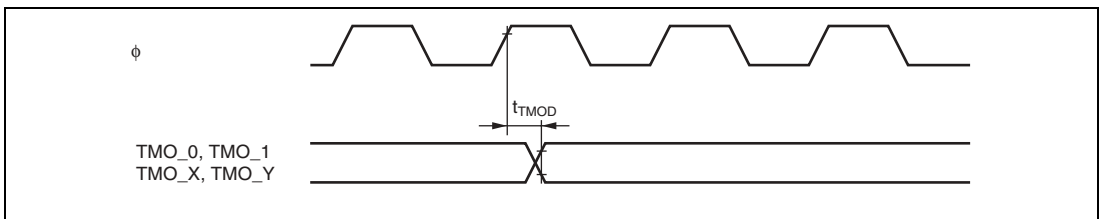

Figure 25.22 8-Bit Timer Output Timing

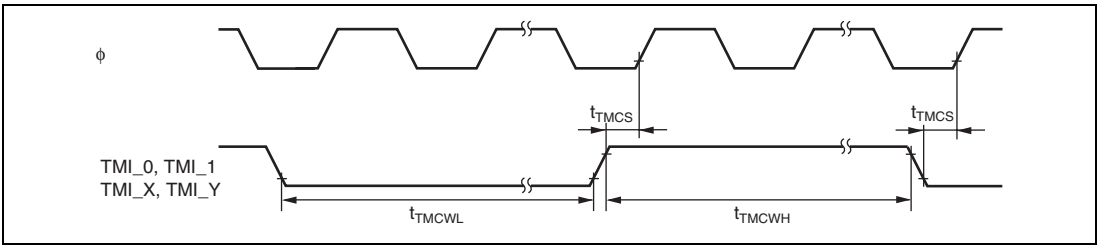

Figure 25.23 8-Bit Timer Clock Input Timing

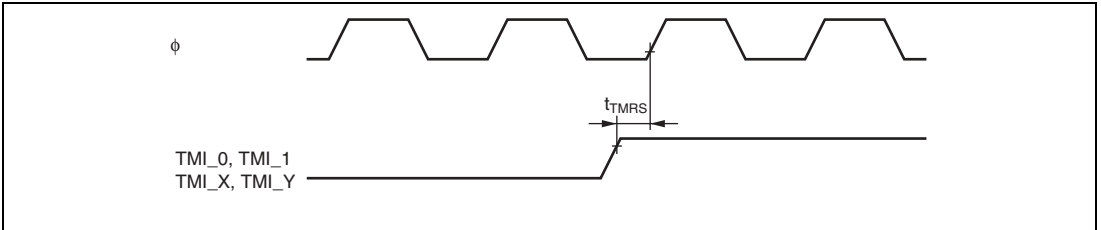

Figure 25.24 8-Bit Timer Reset Input Timing

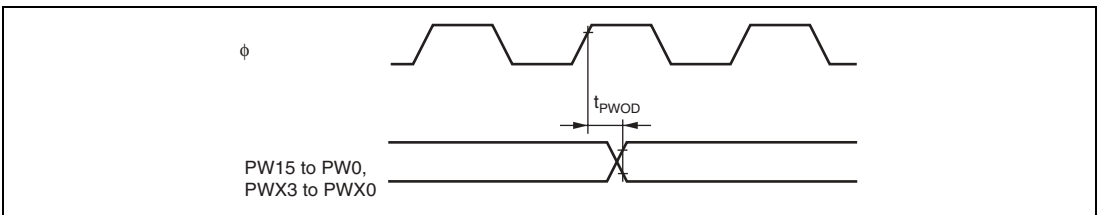

Figure 25.25 PWM, PWMX Output Timing

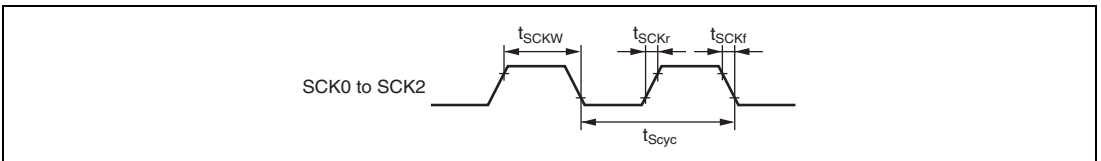

Figure 25.26 SCK Clock Input Timing

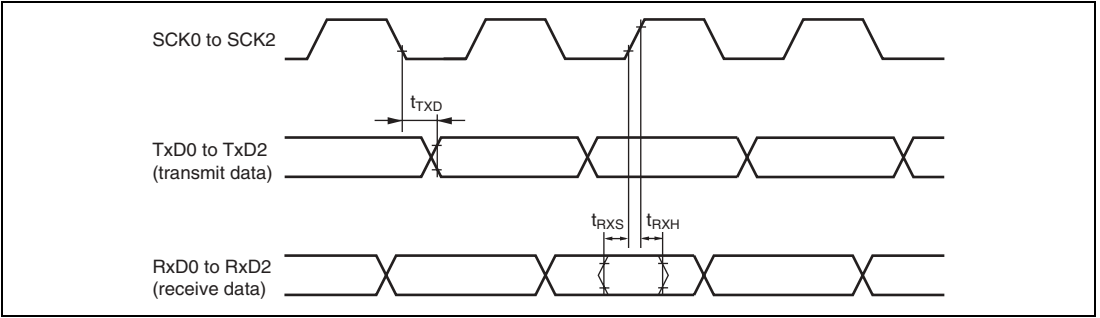

Figure 25.27 SCI Input/Output Timing (Clock Synchronous Mode)

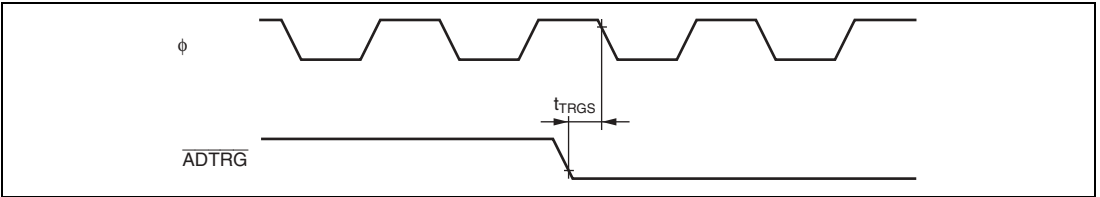

Figure 25.28 A/D Converter External Trigger Input Timing

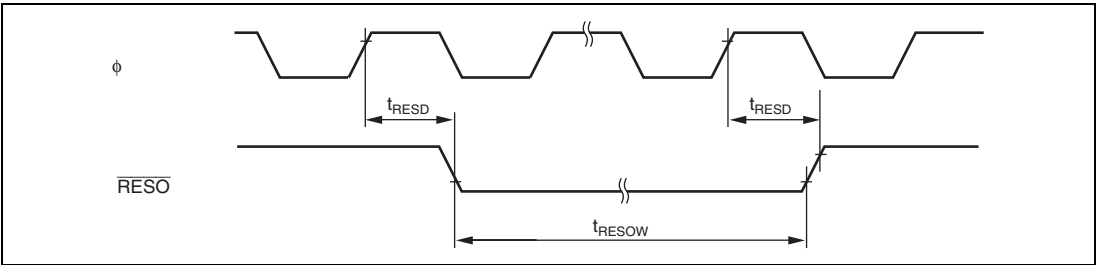

Figure 25.29 WDT Output Timing (\overline{RESO})

Table 25.11 I²C Bus TimingCondition: VCC = 3.0 V to 3.6 V, VSS = 0 V, ϕ = 5 MHz to 33 MHz

Item	Symbol	Min.	Typ.	Max.	Unit	Test Conditions
SCL input cycle time	t_{SCL}	12	—	—	t_{cyc}	Figure 25.30
SCL input high pulse width	t_{SCLH}	3	—	—		
SCL input low pulse width	t_{SCLL}	5	—	—		
SCL, SDA input rise time	t_{Sr}	—	—	7.5*		
SCL, SDA input fall time	t_{Sf}	—	—	300	ns	
SCL, SDA output fall time	t_{Of}	$20 + 0.1 C_b$	—	250		
SCL, SDA input spike pulse elimination time	t_{SP}	—	—	1	t_{cyc}	
SDA input bus free time	t_{BUF}	5	—	—		
Start condition input hold time	t_{STAH}	3	—	—		
Retransmission start condition input setup time	t_{STAS}	3	—	—		
Stop condition input setup time	t_{STOS}	3	—	—		
Data input setup time	t_{SDAS}	0.5	—	—		
Data input hold time	t_{SDAH}	0	—	—	ns	
SCL, SDA capacitive load	C_b	—	—	400	pF	

Note: * $17.5 t_{cyc}$ or $37.5 t_{cyc}$ can be set according to the clock selected for use by the IIC module.

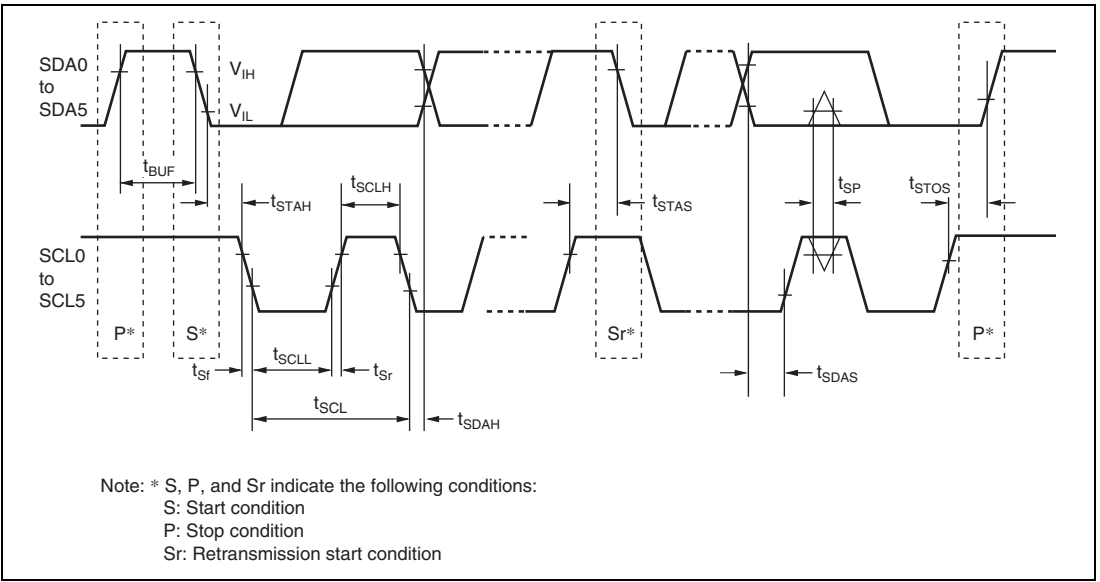

Figure 25.30 I²C Bus Interface Input/Output Timing

Table 25.12 LPC Module Timing

Conditions: VCC = 3.0 V to 3.6V, VSS = 0 V, ϕ = 5 MHz to 33 MHz

Item	Symbol	Min.	Typ.	Max.	Unit	Test Conditions
Input clock cycle	t_{Lcyc}	30	—	—	ns	Figure 25.31
Input clock pulse width (H)	t_{LCKH}	11	—	—		
Input clock pulse width (L)	t_{LCKL}	11	—	—		
Transmit signal delay time	t_{TXD}	2	—	11		
Transmit signal floating delay time	t_{OFF}	—	—	28		
Receive signal setup time	t_{RXS}	7	—	—		
Receive signal hold time	t_{RXH}	0	—	—		

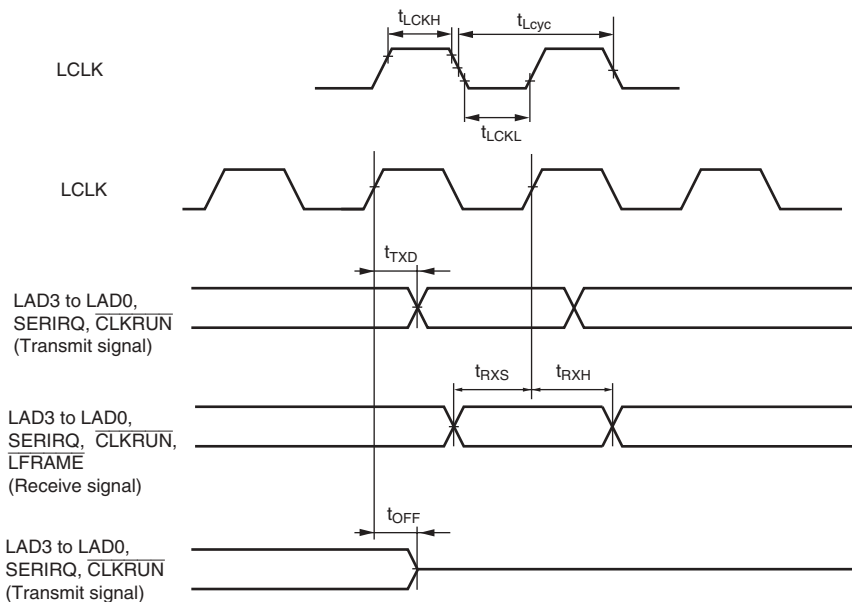

Figure 25.31 LPC Interface (LPC) Timing

Table 25.13 JTAG Timing

Condition: VCC = 3.0 V to 3.6 V, VSS = 0 V, ϕ = 5 MHz to 33 MHz

Item	Symbol	Min.	Max.	Unit	Test Conditions
ETCK clock cycle time	t_{TCKcyc}	40*	200*	ns	Figure 25.32
ETCK clock high pulse width	t_{TCKH}	15	—		
ETCK clock low pulse width	t_{TCKL}	15	—		
ETCK clock rise time	t_{TCKr}	—	5		
ETCK clock fall time	t_{TCKf}	—	5		
ETRST pulse width	t_{TRSTW}	20	—	t_{cyc}	Figure 25.33
Reset hold transition pulse width	t_{RSTHW}	3	—		
ETMS setup time	t_{TMSS}	20	—	ns	Figure 25.34
ETMS hold time	t_{TMSh}	20	—		
ETDI setup time	t_{TDis}	20	—		
ETDI hold time	t_{TDIH}	20	—		
ETDO data delay time	t_{TDOD}	—	20		

Note: * When $t_{cyc} \leq t_{TCKcyc}$

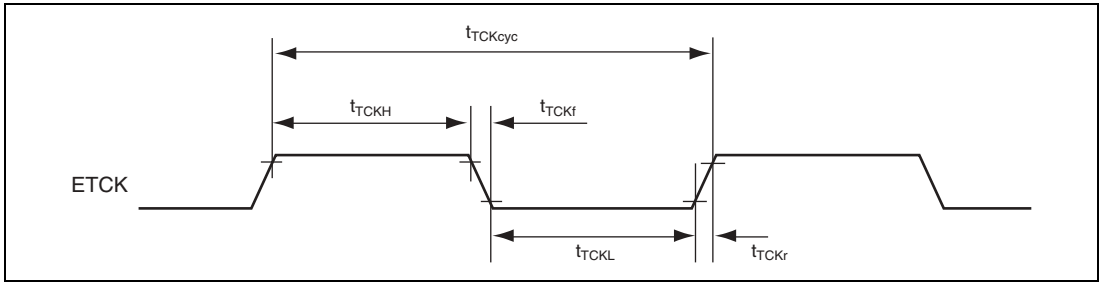

Figure 25.32 JTAG ETCK Timing

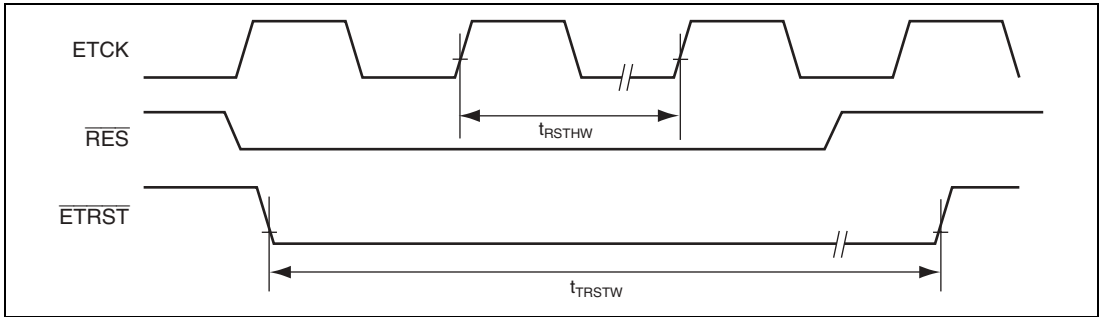

Figure 25.33 Reset Hold Timing

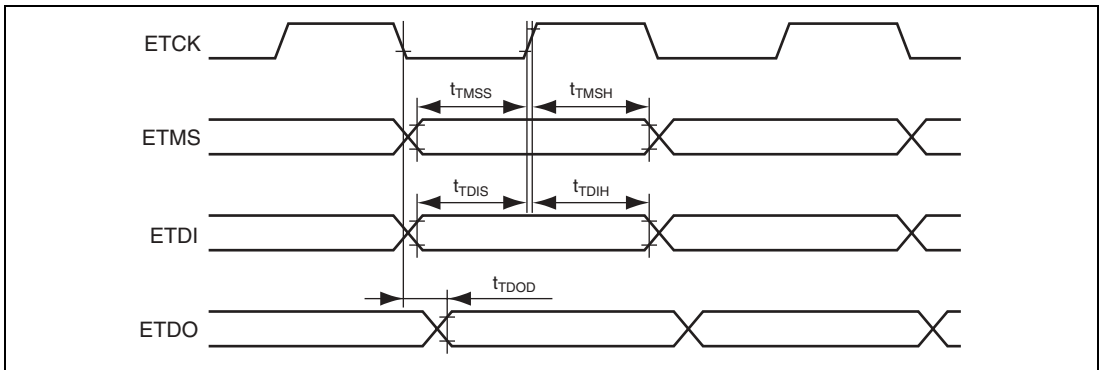

Figure 25.34 JTAG Input/Output Timing

25.4 A/D Conversion Characteristics

Table 25.14 lists the A/D conversion characteristics.

Table 25.14 A/D Conversion Characteristics
(AN7 to AN0 Input: 134/266-State Conversion)

Condition A: VCC = 3.0 V to 3.6 V, AVCC = 3.0 V to 3.6 V, AVref = 3.0 V to AVCC
VSS = AVSS = 0 V, ϕ = 5 MHz to 16 MHz

Condition B: VCC = 3.0 V to 3.6 V, AVCC = 3.0 V to 3.6 V, AVref = 3.0 V to AVCC,
VSS = AVSS = 0 V, ϕ = 5 MHz to 33 MHz

Item	Condition A			Condition B			Unit
	Min.	Typ.	Max.	Min.	Typ.	Max.	
Resolution		10			10		Bits
Conversion time	—	—	8.38* ¹	—	—	8.06* ²	μ s
Analog input capacitance	—	—	20	—	—	20	pF
Permissible signal-source impedance	—	—	5	—	—	5	k Ω
Nonlinearity error	—	—	± 7.0	—	—	± 7.0	LSB
Offset error	—	—	± 7.5	—	—	± 7.5	
Full-scale error	—	—	± 7.5	—	—	± 7.5	
Quantization error	—	—	± 0.5	—	—	± 0.5	
Absolute accuracy	—	—	± 8.0	—	—	± 8.0	

Notes: 1. Value when using the maximum operating frequency in single mode of 134 states.
2. Value when using the maximum operating frequency in single mode of 266 states.

25.5 D/A Conversion Characteristics

Table 25.15 lists the D/A conversion characteristics.

Table 25.15 D/A Conversion Characteristics

Condition: VCC = 3.0 V to 3.6 V, AVCC = 3.0 V to 3.6 V, AVref = 3.0 V to AVCC
VSS = AVSS = 0 V, ϕ = 5 MHz to 33 MHz

Item		Min.	Typ.	Max.	Unit
Resolution		8	8	8	Bits
Conversion time	Load capacitance 20 pF	—	—	10	μ s
Absolute accuracy	Load resistance 2 M Ω	—	± 2.0	± 3.0	LSB
	Load resistance 4 M Ω	—	—	± 2.0	

25.6 Flash Memory Characteristics

Table 25.16 lists the flash memory characteristics.

Table 25.16 Flash Memory Characteristics

Condition: VCC = 3.0 V to 3.6 V, AVCC = 3.0 V to 3.6 V, Avref = 3.0 V to AVCC, VSS = AVSS = 0 V

Ta = 0°C to +75°C (operating temperature range for programming/erasing in regular specifications)

Ta = 0°C to +85°C (operating temperature range for programming/erasing in wide-range specifications)

- H8S/2168

Item	Symbol	Min.	Typ.	Max.	Unit	Test Conditions
Programming time* ¹ * ² * ⁴	t _p	—	3	30	ms/128 bytes	
Erase time* ¹ * ² * ⁴	t _E	—	80	800	ms/4-kbyte block	
		—	500	5000	ms/32-kbyte block	
		—	1000	10000	ms/64-kbyte block	
Programming time (total)* ¹ * ² * ⁴	Σ t _p	—	5	15	s/256 kbytes	Ta = 25°C
Erase time (total)* ¹ * ² * ⁴	Σ t _E	—	5	15	s/256 kbytes	Ta = 25°C
Programming and Erase time (total)* ¹ * ² * ⁴	Σ t _{PE}	—	10	30	s/256 kbytes	Ta = 25°C
Reprogramming count* ⁵	N _{WEC}	100* ³	1000	—	Times	
Data retention time* ⁴	t _{DRP}	10	—	—	Years	

Notes: 1. Programming and erase time depends on the data.

2. Programming and erase time do not include data transfer time.

3. This value indicates the minimum number of which the flash memory are reprogrammed with all characteristics guaranteed. (The guaranteed value ranges from 1 to the minimum number.)

4. This value indicates the characteristics while the flash memory is reprogrammed within the specified range (including the minimum number).

5. Reprogramming count in each erase block.

Item	Symbol	Min.	Typ.	Max.	Unit	Test Conditions
Programming time* ¹ * ² * ⁴	t_p	—	3	30	ms/128 bytes	
Erase time* ¹ * ² * ⁴	t_E	—	80	800	ms/4-kbyte block	
			500	5000	ms/32-kbyte block	
			1000	10000	ms/64-kbyte block	
Programming time (total)* ¹ * ² * ⁴	Σt_p	—	7.5	22.5	s/384 kbytes	Ta = 25°C
Erase time (total)* ¹ * ² * ⁴	Σt_E	—	7.5	22.5	s/384 kbytes	Ta = 25°C
Programming and Erase time (total)* ¹ * ² * ⁴	Σt_{PE}	—	15	45	s/384 kbytes	Ta = 25°C
Reprogramming count* ⁵	N_{WEC}	100* ³	1000	—	Times	
Data retention time* ⁴	t_{DRP}	10	—	—	Years	

- Notes: 1. Programming and erase time depends on the data.
 2. Programming and erase time do not include data transfer time.
 3. This value indicates the minimum number of which the flash memory are reprogrammed with all characteristics guaranteed. (The guaranteed value ranges from 1 to the minimum number.)
 4. This value indicates the characteristics while the flash memory is reprogrammed within the specified range (including the minimum number).
 5. Reprogramming count in each erase block.

Item	Symbol	Min.	Typ.	Max.	Unit	Test Conditions
Programming time* ¹ * ² * ⁴	t_p	—	3	30	ms/128 bytes	
Erase time* ¹ * ² * ⁴	t_E	—	80	800	ms/4-kbyte block	
			500	5000	ms/32-kbyte block	
			1000	10000	ms/64-kbyte block	
Programming time (total)* ¹ * ² * ⁴	Σt_p	—	10	30	s/512 kbytes	Ta = 25°C
Erase time (total)* ¹ * ² * ⁴	Σt_E	—	10	30	s/512 kbytes	Ta = 25°C
Programming and Erase time (total)* ¹ * ² * ⁴	Σt_{PE}	—	20	60	s/512 kbytes	Ta = 25°C
Reprogramming count* ⁵	N_{WEC}	100* ³	1000	—	Times	
Data retention time* ⁴	t_{DRP}	10	—	—	Years	

- Notes:
1. Programming and erase time depends on the data.
 2. Programming and erase time do not include data transfer time.
 3. This value indicates the minimum number of which the flash memory are reprogrammed with all characteristics guaranteed. (The guaranteed value ranges from 1 to the minimum number.)
 4. This value indicates the characteristics while the flash memory is reprogrammed within the specified range (including the minimum number).
 5. Reprogramming count in each erase block.

25.7 Usage Notes

It is necessary to connect a bypass capacitor between the VCC pin and VSS pin and a capacitor between the VCL pin and VSS pin for stable internal step-down power. An example of connection is shown in figure 25.35.

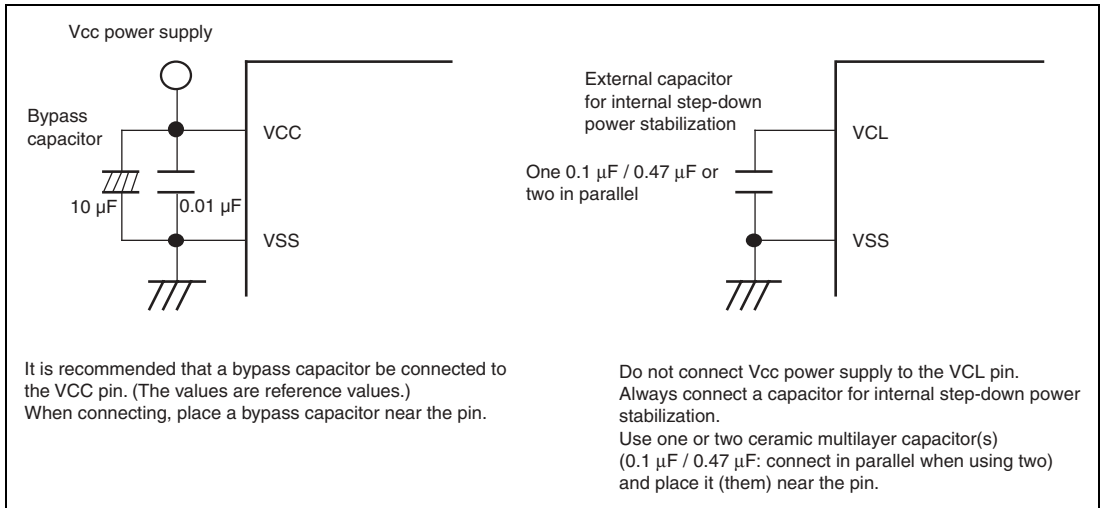

Figure 25.35 Connection of VCL Capacitor

Appendix

A. I/O Port States in Each Pin State

Port Name Pin Name	MCU Operating Mode	Reset	Hardware Standby Mode	Software Standby Mode	Watch Mode	Sleep Mode	Subsleep Mode	Subactive Mode	Program Execution State
Port 1 A7 to A0	(EXPE = 1)	T	T	kept*	kept*	kept*	kept*	Address output/input port	Address output/input port
	(EXPE = 0)							I/O port	I/O port
Port 2 A15 to A8	(EXPE = 1)	T	T	kept*	kept*	kept*	kept*	Address output/ I/O port	Address output/ I/O port
	(EXPE = 0)							I/O port	I/O port
Port 3 D15 to D8	(EXPE = 1)	T	T	T	T	T	T	D15 to D8	D15 to D8
	(EXPE = 0)			kept	kept	kept	kept	I/O port	I/O port
Port 4	(EXPE = 1)	T	T	kept	kept	kept	kept	I/O port	I/O port
	(EXPE = 0)								
Port 5	(EXPE = 1)	T	T	kept	kept	kept	kept	I/O port	I/O port
	(EXPE = 0)								
Port 6 D7 to D0	(EXPE = 1)	T	T	kept	kept	kept	kept	D7 to D0/ I/O port	D7 to D0/ I/O port
	(EXPE = 0)							I/O port	I/O port
Port 7	(EXPE = 1)	T	T	T	T	T	T	Input port	Input port
	(EXPE = 0)								
Port 8	(EXPE = 1)	T	T	kept	kept	kept	kept	I/O port	I/O port
	(EXPE = 0)								
Port 97 WAIT, CS256	(EXPE = 1)	T	T	T/kept	T/kept	T/kept	T/kept	WAIT/CS256/ I/O port	WAIT/CS256 //I/O port
	(EXPE = 0)			kept	kept	kept	kept	I/O port	I/O port
Port 96 φ, EXCL	(EXPE = 1)	T	T	[DDR = 1] H	EXCL input	[DDR = 1] Clock output	EXCL input	EXCL input	Clock output/ EXCL input/ Input port
	(EXPE = 0)			[DDR = 0] T		[DDR = 0] T			

Port Name Pin Name	MCU Operating Mode	Reset	Hardware Standby Mode	Software Standby Mode	Watch Mode	Sleep Mode	Subsleep Mode	Subactive Mode	Program Execution State
Port 95 to 93 \overline{AS} , \overline{IOS} , \overline{HWR} , \overline{RD}	(EXPE = 1)	T	T	H	H	H	H	$\overline{AS}/\overline{IOS}$, $\overline{HWR}/\overline{RD}$	$\overline{AS}/\overline{IOS}$, $\overline{HWR}/\overline{RD}$
	(EXPE = 0)			kept	kept	kept	kept	I/O port	I/O port
Port 92 and 91 $\overline{CPCS1}$	(EXPE = 1)	T	T	kept	kept	kept	kept	$\overline{CPCS1}/$ I/O port	$\overline{CPCS1}/$ I/O port
	(EXPE = 0)							I/O port	I/O port
Port 90 \overline{LWR}	(EXPE = 1)	T	T	H/kept	H/kept	H/kept	H/kept	$\overline{LWR}/$ I/O port	$\overline{LWR}/$ I/O port
	(EXPE = 0)			kept	kept	kept	kept	I/O port	I/O port
Port A A23 to A16	(EXPE = 1)	T	T	kept*	kept*	kept*	kept*	Address output/ I/O port	Address output/ I/O port
	(EXPE = 0)							I/O port	I/O port
Port B	(EXPE = 1)	T	T	kept	kept	kept	kept	I/O port	I/O port
	(EXPE = 0)								
Port C	(EXPE = 1)	T	T	kept	kept	kept	kept	I/O port	I/O port
	(EXPE = 0)								
Port D	(EXPE = 1)	T	T	kept	kept	kept	kept	I/O port	I/O port
	(EXPE = 0)								
Port E	(EXPE = 1)	T	T	kept	kept	kept	kept	I/O port	I/O port
	(EXPE = 0)								
Port F	(EXPE = 1)	T	T	kept	kept	kept	kept	I/O port	I/O port
	(EXPE = 0)								

Legend

H: High level

L: Low level

T: High impedance

kept: Input ports are in the high-impedance state (when DDR = 0 and PCR = 1, the input pull-up MOS remains on).

Output ports maintain their previous state.

Depending on the pins, the on-chip peripheral modules may be initialized and the I/O port function determined by DDR and DR.

DDR: Data direction register

Note: * In the case of address output, the last address accessed is retained.

B. Product Lineup

Product Type	Type Code	Mark Code	Package (Code)
H8S/2168 F-ZTAT version	HD64F2168	F2168VTE33	144-pin TQFP (TFP-144)
H8S/2167	HD64F2167	F2167VTE33	
H8S/2166	HD64F2166	F2166VTE33	

C. Package Dimensions

For package dimensions, dimensions described in Renesas Semiconductor Packages have priority.

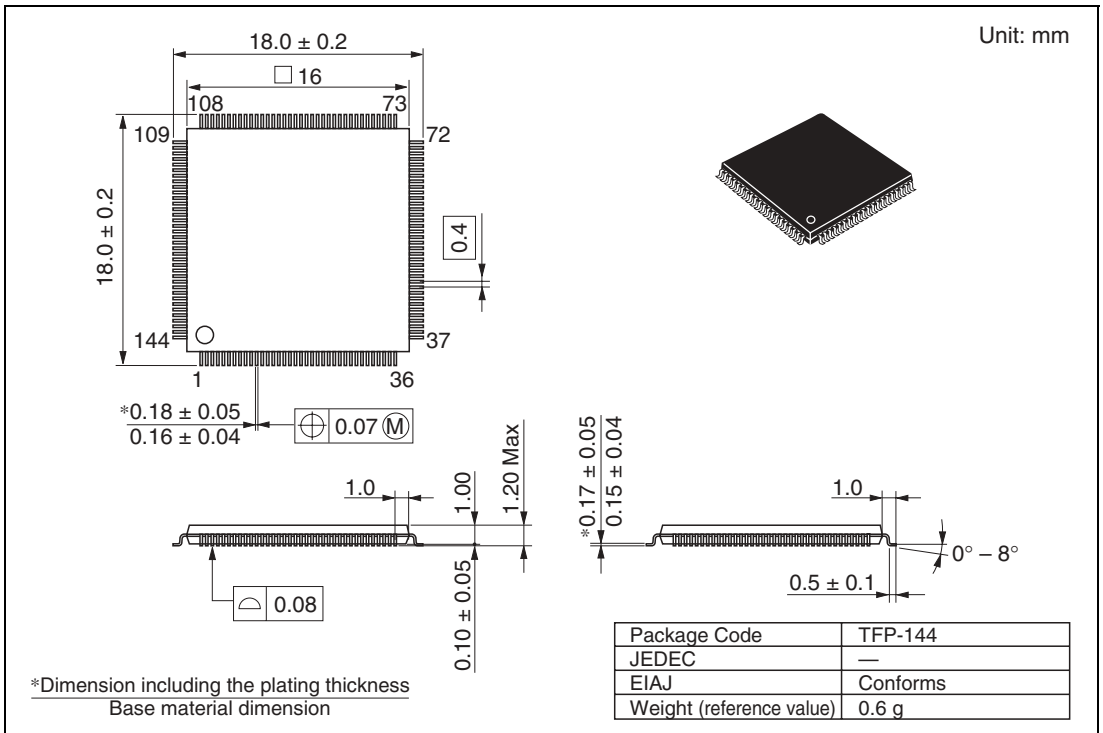

Figure C.1 Package Dimensions (TFP-144)

Main Revisions and Additions in this Edition

Item	Page	Revisions (See Manual for Details)																																																		
Section 5 Interrupt Controller	100	Section 5.7.4 added.																																																		
5.7.4 Note on IRQ Status Registers (ISR16, ISR)																																																				
Section 12 8-bit Timer 12.1 Features	305	<ul style="list-style-type: none"> Cascading of TMR_0 and TMR_1 (Cascading of TMR_Y and TMR_X is not allowed) <ul style="list-style-type: none"> Operation as a 16-bit timer can be performed using TMR_0 as the upper half and TMR_1 as the lower half (16-bit count mode). TMR_1 can be used to count TMR_0 compare-match occurrences (compare match count mode) 																																																		
Section 12.3.4 Timer Control register (TCR)	312, 313	Description amended.																																																		
Table 12.2 Clock Input to TCNT and Count Condition		<table border="1"> <thead> <tr> <th rowspan="2">Channel</th> <th colspan="3">TCR</th> <th rowspan="2">Description</th> </tr> <tr> <th>CKS2</th> <th>CKS1</th> <th>CKS0</th> </tr> </thead> <tbody> <tr> <td rowspan="5">TMR_Y</td> <td>0</td> <td>0</td> <td>0</td> <td>Disables clock input</td> </tr> <tr> <td>0</td> <td>0</td> <td>1</td> <td>Increments at falling edge of internal clock $\phi/4$</td> </tr> <tr> <td>0</td> <td>1</td> <td>0</td> <td>Increments at falling edge of internal clock $\phi/256$</td> </tr> <tr> <td>0</td> <td>1</td> <td>1</td> <td>Increments at falling edge of internal clock $\phi/2048$</td> </tr> <tr> <td>1</td> <td>0</td> <td>0</td> <td>Setting prohibited</td> </tr> <tr> <td rowspan="5">TMR_X</td> <td>0</td> <td>0</td> <td>0</td> <td>Disables clock input</td> </tr> <tr> <td>0</td> <td>0</td> <td>1</td> <td>Increments at falling edge of internal clock ϕ</td> </tr> <tr> <td>0</td> <td>1</td> <td>0</td> <td>Increments at falling edge of internal clock $\phi/2$</td> </tr> <tr> <td>0</td> <td>1</td> <td>1</td> <td>Increments at falling edge of internal clock $\phi/4$</td> </tr> <tr> <td>1</td> <td>0</td> <td>0</td> <td>Setting prohibited</td> </tr> </tbody> </table>	Channel	TCR			Description	CKS2	CKS1	CKS0	TMR_Y	0	0	0	Disables clock input	0	0	1	Increments at falling edge of internal clock $\phi/4$	0	1	0	Increments at falling edge of internal clock $\phi/256$	0	1	1	Increments at falling edge of internal clock $\phi/2048$	1	0	0	Setting prohibited	TMR_X	0	0	0	Disables clock input	0	0	1	Increments at falling edge of internal clock ϕ	0	1	0	Increments at falling edge of internal clock $\phi/2$	0	1	1	Increments at falling edge of internal clock $\phi/4$	1	0	0	Setting prohibited
Channel	TCR			Description																																																
	CKS2	CKS1	CKS0																																																	
TMR_Y	0	0	0	Disables clock input																																																
	0	0	1	Increments at falling edge of internal clock $\phi/4$																																																
	0	1	0	Increments at falling edge of internal clock $\phi/256$																																																
	0	1	1	Increments at falling edge of internal clock $\phi/2048$																																																
	1	0	0	Setting prohibited																																																
TMR_X	0	0	0	Disables clock input																																																
	0	0	1	Increments at falling edge of internal clock ϕ																																																
	0	1	0	Increments at falling edge of internal clock $\phi/2$																																																
	0	1	1	Increments at falling edge of internal clock $\phi/4$																																																
	1	0	0	Setting prohibited																																																
		Note: * If the TMR_0 clock input is set as the TCNT_1 overflow signal and the TMR_1 clock input is set as the TCNT_0 compare-match signal simultaneously, a count-up clock cannot be generated. Setting of these conditions should therefore be avoided.																																																		

Section 14 Serial Communication Interface (SCI)	352	<p>Feature of asynchronous mode added.</p> <ul style="list-style-type: none"> Average transfer rate generator (SCI_0 and SCI_2): 460.606 kbps or 115.152 kbps selectable at 10.667-MHz operation; 720 kbps, 460.784 kbps, 230.392 kbps, or 115.196 kbps selectable at 16- or 24-MHz operation; 230.392 kbps or 115.196 kbps selectable at 20-MHz operation; and 720 kbps selectable at 32-MHz operation
---	-----	--

14.3.10 Serial Interface Control register (SCICR)	375	<p>Description amended.</p> <p style="text-align: center;">Initial</p> <table border="1"> <thead> <tr> <th>Bit</th> <th>Bit Name</th> <th>Value</th> <th>R/W</th> <th>Description</th> </tr> </thead> <tbody> <tr> <td>3, 2</td> <td>—</td> <td>All 0</td> <td>R/W</td> <td>Reserved The initial value should no be changed.</td> </tr> </tbody> </table>	Bit	Bit Name	Value	R/W	Description	3, 2	—	All 0	R/W	Reserved The initial value should no be changed.
Bit	Bit Name	Value	R/W	Description								
3, 2	—	All 0	R/W	Reserved The initial value should no be changed.								

14.3.11 Serial Enhanced Mode Register_0 and 2 (SEMR_0 and SEMR_2)	377	<p>Description amended.</p> <p style="text-align: center;">Initial</p> <table border="1"> <thead> <tr> <th>Bit</th> <th>Bit Name</th> <th>Value</th> <th>R/W</th> <th>Description</th> </tr> </thead> <tbody> <tr> <td>4</td> <td>ACS4</td> <td>0</td> <td>R/W</td> <td rowspan="5">0011: Average transfer rate operation at 720 kbps when the system clock frequency is 32 MHz (operated using the basic clock with a frequency 16 times the transfer clock frequency)</td> </tr> <tr> <td>2</td> <td>ACS2</td> <td>0</td> <td>R/W</td> </tr> <tr> <td>1</td> <td>ACS1</td> <td>0</td> <td>R/W</td> </tr> <tr> <td>0</td> <td>ACS0</td> <td>0</td> <td>R/W</td> </tr> </tbody> </table>	Bit	Bit Name	Value	R/W	Description	4	ACS4	0	R/W	0011: Average transfer rate operation at 720 kbps when the system clock frequency is 32 MHz (operated using the basic clock with a frequency 16 times the transfer clock frequency)	2	ACS2	0	R/W	1	ACS1	0	R/W	0	ACS0	0	R/W
Bit	Bit Name	Value	R/W	Description																				
4	ACS4	0	R/W	0011: Average transfer rate operation at 720 kbps when the system clock frequency is 32 MHz (operated using the basic clock with a frequency 16 times the transfer clock frequency)																				
2	ACS2	0	R/W																					
1	ACS1	0	R/W																					
0	ACS0	0	R/W																					

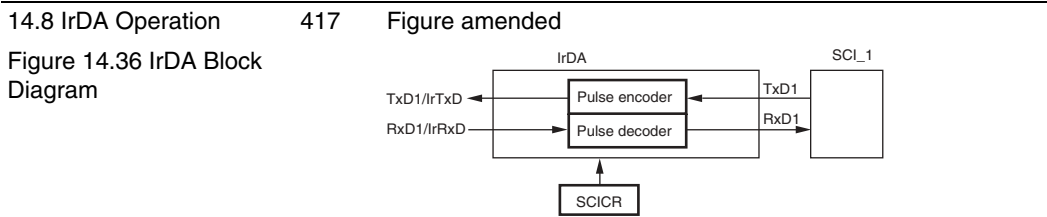

Item	Page	Revisions (See Manual for Details)																																				
Transmission:	417, 418	Deleted The output waveform can also be inverted using the IrTxINV bit in SCICR.																																				
Reception:		Deleted Here, the input waveform can also be inverted using the IrRxINV bit in SCICR.																																				
Section 15 I ² C Bus Interface (IIC) 15.6 Usage Notes	505	Added																																				
Section 21 Boundary Scan (JTAG) 21.5.1 Supported Instructions IDCODE: Instruction Code: B'1110	717	Modified 6. Use the \overline{STBY} pin in high state.																																				
Section 24 List of Registers 24.2 Register Bits	766	Description amended. <table border="1"> <thead> <tr> <th>Register</th> <th>Abbreviation</th> <th>Bit 7</th> <th>Bit 6</th> <th>Bit 5</th> <th>Bit 4</th> <th>Bit 3</th> <th>Bit 2</th> <th>Bit 1</th> <th>Bit 0</th> </tr> </thead> <tbody> <tr> <td>SCICR</td> <td>IrE</td> <td>IrCKS2</td> <td>IrCKS1</td> <td>IrCKS0</td> <td>—</td> <td>—</td> <td>—</td> <td>—</td> <td>—</td> </tr> </tbody> </table>	Register	Abbreviation	Bit 7	Bit 6	Bit 5	Bit 4	Bit 3	Bit 2	Bit 1	Bit 0	SCICR	IrE	IrCKS2	IrCKS1	IrCKS0	—	—	—	—	—																
Register	Abbreviation	Bit 7	Bit 6	Bit 5	Bit 4	Bit 3	Bit 2	Bit 1	Bit 0																													
SCICR	IrE	IrCKS2	IrCKS1	IrCKS0	—	—	—	—	—																													
Section 25 Electrical Characteristics 25.2 DC Characteristics Table 25.2 DC Characteristics (1)	784	Amended <table border="1"> <thead> <tr> <th>Item</th> <th>Symbol</th> <th>Min.</th> <th>Typ.</th> <th>Max.</th> <th>Test Conditions</th> </tr> </thead> <tbody> <tr> <td>Input low voltage</td> <td>\overline{RES}, \overline{STBY}, (3) V_L</td> <td>-0.3</td> <td>—</td> <td>$V_{CC} \times 0.1$</td> <td></td> </tr> <tr> <td></td> <td>$\overline{MD2}$, MD1, MD0</td> <td></td> <td></td> <td></td> <td></td> </tr> <tr> <td></td> <td>EXTAL</td> <td>-0.3</td> <td>—</td> <td>$V_{CC} \times 0.1$</td> <td>$f > 25$ MHz</td> </tr> <tr> <td></td> <td></td> <td>-0.3</td> <td>—</td> <td>$V_{CC} \times 0.2$</td> <td>$f \leq 25$ MHz</td> </tr> <tr> <td></td> <td>Port 7</td> <td>-0.3</td> <td>—</td> <td>$AV_{CC} \times 0.2$</td> <td></td> </tr> </tbody> </table>	Item	Symbol	Min.	Typ.	Max.	Test Conditions	Input low voltage	\overline{RES} , \overline{STBY} , (3) V_L	-0.3	—	$V_{CC} \times 0.1$			$\overline{MD2}$, MD1, MD0						EXTAL	-0.3	—	$V_{CC} \times 0.1$	$f > 25$ MHz			-0.3	—	$V_{CC} \times 0.2$	$f \leq 25$ MHz		Port 7	-0.3	—	$AV_{CC} \times 0.2$	
Item	Symbol	Min.	Typ.	Max.	Test Conditions																																	
Input low voltage	\overline{RES} , \overline{STBY} , (3) V_L	-0.3	—	$V_{CC} \times 0.1$																																		
	$\overline{MD2}$, MD1, MD0																																					
	EXTAL	-0.3	—	$V_{CC} \times 0.1$	$f > 25$ MHz																																	
		-0.3	—	$V_{CC} \times 0.2$	$f \leq 25$ MHz																																	
	Port 7	-0.3	—	$AV_{CC} \times 0.2$																																		

Table 25.2 DC Characteristics (2)	785	Description amended.																												
		<table border="1"> <thead> <tr> <th>Item</th> <th>Symbol</th> <th>Min.</th> <th>Typ.</th> <th>Max.</th> <th>Unit</th> </tr> </thead> <tbody> <tr> <td rowspan="3">Current consumption*⁵</td> <td>Normal operation</td> <td>I_{CC}</td> <td>—</td> <td>43</td> <td>55 mA</td> </tr> <tr> <td>Sleep mode</td> <td>—</td> <td>30</td> <td>40</td> <td></td> </tr> <tr> <td>Standby mode*⁶</td> <td>—</td> <td>38</td> <td>90</td> <td>μA</td> </tr> <tr> <td></td> <td></td> <td></td> <td></td> <td>120</td> <td></td> </tr> </tbody> </table>	Item	Symbol	Min.	Typ.	Max.	Unit	Current consumption* ⁵	Normal operation	I_{CC}	—	43	55 mA	Sleep mode	—	30	40		Standby mode* ⁶	—	38	90	μ A					120	
Item	Symbol	Min.	Typ.	Max.	Unit																									
Current consumption* ⁵	Normal operation	I_{CC}	—	43	55 mA																									
	Sleep mode	—	30	40																										
	Standby mode* ⁶	—	38	90	μ A																									
				120																										

25.3 AC Characteristics	794,	Description amended.										
25.3.3 Bus Timing	800											
Table 25.8 Bus Timing		<table border="1"> <thead> <tr> <th>Item</th> <th>Symbol</th> <th>Min.</th> <th>Max.</th> <th>Unit</th> </tr> </thead> <tbody> <tr> <td>Write data hold time</td> <td>t_{WDH}</td> <td>$0.5 \times t_{cyc} - 5$</td> <td>—</td> <td>ns</td> </tr> </tbody> </table>	Item	Symbol	Min.	Max.	Unit	Write data hold time	t_{WDH}	$0.5 \times t_{cyc} - 5$	—	ns
Item	Symbol	Min.	Max.	Unit								
Write data hold time	t_{WDH}	$0.5 \times t_{cyc} - 5$	—	ns								

25.3.4 Multiplex Bus Timing		
Table 25.9 Multiplex Bus Timing		

25.6 Flash Memory Characteristics	813 to 815	Description amended and added.
Table 25.16 Flash Memory Characteristics		<p>$T_a = 0^\circ\text{C}$ to $+75^\circ\text{C}$ (operating temperature range for programming/erasing in regular specifications)</p> <p>$T_a = 0^\circ\text{C}$ to $+85^\circ\text{C}$ (operating temperature range for programming/erasing in wide-range specifications)</p>

Item	Symbol	Min.	Typ.	Max.	Unit	Test Conditions
Reprogramming count* ⁵	N_{WEC}	100* ³	1000	—	Times	

Notes: 5. Reprogramming count in each erase block.

Index

14-bit PWM timer (PWMX).....	261	Bit manipulation instructions	37
16-bit count mode.....	326	Bit rate.....	369
16-bit free-running timer (FRT)	277	Block data transfer instructions.....	41
16-bit, 2-state access space	129	Block transfer mode	168
16-bit, 3-state access space	132	Boot mode.....	638
256-kbyte expansion area	116	Boundary scan.....	715
8-bit PWM timer (PWM).....	251	Branch instructions	39
8-bit timer (TMR).....	305	BRR	369, 759, 770, 780
8-bit, 2-state access space	127	Burst ROM interface.....	145
8-bit, 3-state access space	128	Bus specifications of basic bus interface	114
A/D conversion time.....	602	Carrier frequency	253
A/D converter	595	Cascaded connection.....	326
ABRKCR.....	75, 755, 766, 777	Chain transfer.....	169
Absolute address.....	44	Clock pulse generator	721
Acknowledge.....	466	Clocked synchronous mode	399
Activation by interrupt.....	173	CMIA	329
Activation by software.....	173	CMIA0	329
ADCR.....	600, 760, 771, 781	CMIA1	329
ADCSR.....	599, 760, 771, 781	CMIAX	329
Additional pulse.....	259	CMIAY	329
ADDR.....	598, 759, 771, 780	CMIB	329
Address map	60	CMIB0	329
Address ranges and external address spaces.....	113	CMIB1	329
Address space	22	CMIBX	329
Addressing modes.....	43	CMIBY	329
ADI	604	Communications protocol.....	672
Advanced mode	122	Compare-match count mode	326
Arithmetic operations instructions.....	34	Condition field	41
Asynchronous mode	380	Condition-code register.....	26
BARA	76, 755, 766, 777	Conversion cycle.....	269
BARB	76, 755, 766, 777	CP expansion area (basic mode)	117
BARC	76, 755, 766, 777	CPU.....	15
Basic expansion area.....	115	CPU operating modes	18
Basic operation timing.....	145	CRA	154
Basic pulse.....	258	CRB	154
		CRC operation circuit	428
		CRCCR	429, 754, 765, 776
		CRCDIR.....	429, 754, 765, 776

CRCDOR.....	429, 754, 765, 776	Framing error	389
Crystal oscillator.....	722	FRC.....	280, 756, 767, 778
D/A converter	589	FTDAR	627, 753, 764, 775
DACR.....	266, 591, 754, 761,765, 771, 776, 781	General registers	24
DADR.....	591, 761, 771, 781	Hardware protection	665
DADRA.....	754, 765, 776	Hardware standby mode	743
DADRB.....	754, 765, 776	HICR.....	512, 518, 751, 763, 774
DAR.....	153	I/O ports	177
Data direction register	177	I/O select signals.....	123
Data register.....	177	I ² C bus formats	465
Data transfer controller (DTC)	149	I ² C bus interface (IIC).....	435
Data transfer instructions.....	33	IBF	584
Direct transitions	747	ICCR.....	446, 759, 770, 780
DTC vector table	162	ICDR.....	439, 759, 770, 780
DTCERA	155, 755, 766, 777	ICIA	298
DTCERB	155, 755, 766, 777	ICIB	298
DTCERC	155, 755, 766, 777	ICIC	298
DTCERD	155, 755, 766, 777	ICID	298
DTCERE	155, 755, 766, 777	ICIX	329
DTVECR.....	155, 755, 766, 777	ICMR.....	442, 759, 770, 780
Effective address	47	ICRA.....	75, 754, 766, 777
Effective address extension	41	ICRB	75, 754, 766, 777
ER10.....	420	ICRC	75, 754, 766, 777
ER11.....	420	ICRD.....	75, 754, 766, 776
ER12.....	420	ICSMBCR.....	463, 754, 766, 776
ERR1	584	ICSR	455, 759, 770, 780
Error protection	666	ICXR.....	459, 754, 765, 776
Exception handling.....	63	IDR	527, 751, 763, 774
Exception handling vector table	64	IER.....	79, 758, 769, 779
Extended control register.....	25	IER16.....	79, 755, 766, 777
External clock	723	Immediate	45
External trigger.....	603	Input capture	292
FCCS	622, 753, 764, 775	Input capture operation	327
FECS	624, 753, 764, 775	Input pull-up MOS control register.....	177
FKEY.....	625, 753, 764, 775	Input pull-up MOSs	177
Flash MAT configuration	615	Instruction set.....	31
FMATS.....	626, 753, 764, 775	Interface	351
FOVI.....	298	Internal block diagram	2
FPCS.....	624, 753, 764, 775	Interrupt control modes.....	88
		Interrupt controller.....	71

Interrupt exception handling.....	68	Multiprocessor communication	
Interrupt exception handling sequence	94	function	393
Interrupt exception handling		NMI interrupt.....	82
vector table	85	Normal mode	18, 166, 174
Interrupt mask bit.....	26	Number of DTC execution states.....	171
Interval timer mode.....	345	OCIA.....	298
IrDA.....	417	OCIB.....	298
IRQ15 to IRQ0 interrupts	82	OCRA	280, 756, 767, 778
ISCR	77	OCRAF	281, 756, 768, 778
ISCR16H	77, 755, 766, 777	OCRAR.....	281, 756, 768, 778
ISCR16L.....	77, 755, 766, 777	OCRB	280, 756, 767, 778
ISCRH	78, 754, 766, 777	OCRDM.....	281, 756, 768, 778
ISCR.....	78, 754, 766, 777	ODR.....	527, 751, 763, 774
ISR.....	80, 754, 766, 777	On-board programming	638
ISR16.....	80, 755, 766, 777	On-board programming mode.....	611
ISSR.....	248, 755, 766, 777	Operating modes	53
ISSR16.....	248	Operation field	41
KBCOMP	151, 754, 766, 776	Output compare.....	291
KIN15 to KIN0 interrupts.....	83	Overflow	344
KMIMR6	81, 760, 771, 781	Overrun error	389
KMIMRA	81, 760, 771, 781	OVI	329
KMPCR6	760, 771, 781	OVI0	329
LADR3	522, 751, 763, 774	OVI1	329
Logic operations instructions.....	36	OVI.....	329
LPWRCR.....	730, 755, 767, 777	OVIY	329
LSI internal states in each mode.....	737	P1DDR.....	183, 757, 769, 779
Master receive operation.....	471	P1DR.....	184, 757, 769, 779
Master transmit operation	467	P1PCR.....	184, 757, 769, 779
MDCR	54, 758, 769, 780	P2DDR.....	187, 757, 769, 779
Medium-speed mode	739	P2DR.....	188, 757, 769, 779
Memory indirect	46	P2PCR.....	188, 757, 769, 779
Mode comparison	614	P3DDR.....	191, 757, 769, 779
Mode transition diagram.....	736	P3DR.....	191, 757, 769, 779
Module stop mode	747	P3PCR.....	192, 757, 769, 779
MRA	152	P4DDR.....	196, 757, 769, 779
MRB	153	P4DR.....	196, 757, 769, 779
MSTPCRA	733, 752, 764, 774	P5DDR.....	200, 757, 769, 779
MSTPCRH	732, 755, 767, 777	P5DR.....	200, 757, 769, 779
MSTPCRL.....	732, 755, 767, 777	P6DDR.....	204, 757, 769, 779
		P6DR.....	205, 758, 769, 779

P6NCCS	207, 752, 764, 775	Flash pass/fail parameter.....	637
P6NCE.....	206, 752, 764, 775	Flash programming/erasing frequency	
P6NCMC	207, 752, 764, 775	parameter	631
P7PIN	213, 758, 769, 779	Programming/erasing interface	
P8DDR	217, 758, 769, 779	register	621
P8DR	217, 758, 769, 779	Protection.....	665
P9DDR	222, 758, 769, 779	PTCNT0.....	250, 755, 766, 777
P9DR	223, 758, 769, 779	PWDPR A.....	255, 759, 770, 780
PADDR	226, 757, 769, 779	PWDPRB.....	256, 759, 770, 780
PAODR	227, 757, 769, 779	PWDR.....	255, 759, 770, 780
PAPIN	227, 757, 769, 779	PWM conversion period	253
Parity error.....	389	PWOERA	256, 758, 770, 780
PBDDR.....	232, 758, 769, 779	PWOERB.....	257, 758, 770, 780
PBODR.....	232, 758, 769, 779	PWSL.....	253, 759, 770, 780
PBPIN.....	233, 758, 769, 779	RAM	609
PCDDR.....	235, 752, 764, 775	RDR	356, 759, 770, 780
PCODR.....	235, 752, 764, 775	Register configuration.....	23
PCPIN.....	236, 752, 764, 775	Register direct.....	43
PCSR	267, 755, 767, 777	Register field.....	41
PDDDR	238, 753, 764, 775	Register indirect.....	44
PDODR	239, 752, 764, 775	Register indirect with displacement.....	44
PDPIN	239, 752, 764, 775	Register indirect with post-increment	44
PEDDR.....	243, 752, 764, 775	Register indirect with pre-decrement.....	44
PEODR.....	243, 752, 764, 775	Repeat mode	167
PEPIN	244, 752, 764, 775	Reset	66
PFDDR	246, 752, 764, 775	Reset exception handling	66
PFODR	246, 752, 764, 775	Resolution.....	253
PFPIN	247, 752, 764, 775	RSR.....	356
Pin arrangement.....	3	RXI0	420
Pin functions.....	9	RXI1	420
Power-down modes	727	RXI2	420
Procedure program	655	SAR	440, 759, 770, 780
Processing states	49	SARX.....	441, 759, 770, 780
Program counter	25	SBYCR	728, 755, 767, 777
Program-counter relative	45	Scan mode.....	601
Programmer mode	669	SCICR.....	375, 754, 766, 776
Programming/erasing interface parameter		SCMR	368, 759, 770, 780
Download pass/fail result parameter... 630		SCR.....	361, 759, 770, 780
Flash erase block select parameter..... 636		SDBPR	703
Flash multipurpose address area		SDBSR.....	703
parameter	633	SDIDR	713
Flash multipurpose data destination			
parameter	633		

SDIR.....	701	TCORC.....	319, 761, 771, 781
SEMR.....	376, 754, 765, 776	TCR.....	286, 311, 756, 758, 767, 770, 778, 780
Serial communication interface (SCI)	351	TCSR.....	283, 315, 756, 758, 767, 770, 778, 780
Serial communication interface specification.....	670	TDR.....	357, 759, 770, 780
Serial data reception.....	389, 403	TEI0.....	420
Serial data transmission.....	387, 401	TEI1.....	420
Serial formats.....	465	TEI2.....	420
Shift instructions.....	36	TICR.....	319
Single mode.....	601	TICRF.....	319, 760, 771, 781
SIRQCR.....	536, 751, 763, 774	TICRR.....	319, 760, 771, 781
Slave address.....	466	TIER.....	282, 756, 767, 778
Slave receive operation.....	478	TISR.....	320, 761, 771, 781
Slave transmit operation.....	485	TOCR.....	287, 756, 767, 778
Sleep mode.....	740	Transfer rate.....	444
Smart card.....	351	Trap instruction exception handling.....	68
SMR.....	357, 759, 770, 780	TRAPA instruction.....	68
Software protection.....	666	TSR.....	357
Software standby mode.....	741	TWR.....	528, 750, 762, 773
SSR.....	364, 759, 770, 780	TXI0.....	420
Stack pointer.....	24	TXI1.....	420
Stack status.....	69	TXI2.....	420
Start condition.....	466	User boot MAT.....	668
STCR.....	56, 758, 769, 779	User boot memory MAT.....	611
Stop condition.....	466	User boot mode.....	652
STR.....	529, 751, 763, 774	User MAT.....	668
Subactive mode.....	746	User memory MAT.....	611
SUBMSTPAH.....	734, 752, 763, 774	User program mode.....	642
SUBMSTPAL.....	734, 752, 763, 774	Vector number for the software activation interrupt.....	155
SUBMSTPBH.....	734, 752, 763, 774	Wait control.....	146
SUBMSTPBL.....	734, 752, 763, 774	Watch mode.....	744
Subsleep mode.....	745	Watchdog timer (WDT).....	337
SYSCR.....	55, 758, 769, 780	Watchdog timer mode.....	344
SYSCR2.....	206, 755, 767, 777	WOVI.....	347
System control instructions.....	40	WUE15 to WUE8 interrupts.....	83
TAP controller.....	714	WUEMR3.....	81, 760, 771, 781
TCNT.....	309, 340, 757, 758, 768, 770, 779, 780		
TCONRI.....	320, 761, 772, 781		
TCONRS.....	321, 761, 772, 781		
TCORA.....	310, 758, 770, 780		
TCORB.....	310, 758, 770, 780		

**Renesas 16-Bit Single-Chip Microcomputer
Hardware Manual
H8S/2168 Group**

Publication Date: 1st Edition, Dec, 2002

Rev.3.00, Mar 12, 2004

Published by: Sales Strategic Planning Div.

Renesas Technology Corp.

Edited by: Technical Documentation & Information Department

Renesas Kodaira Semiconductor Co., Ltd.

Renesas Technology Corp. Sales Strategic Planning Div. Nippon Bldg., 2-6-2, Ohte-machi, Chiyoda-ku, Tokyo 100-0004, Japan



RENESAS SALES OFFICES

<http://www.renesas.com>

Renesas Technology America, Inc.
450 Holger Way, San Jose, CA 95134-1368, U.S.A
Tel: <1> (408) 382-7500 Fax: <1> (408) 382-7501

Renesas Technology Europe Limited.
Dukes Meadow, Millboard Road, Bourne End, Buckinghamshire, SL8 5FH, United Kingdom
Tel: <44> (1628) 585 100, Fax: <44> (1628) 585 900

Renesas Technology Europe GmbH
Dornacher Str. 3, D-85622 Feldkirchen, Germany
Tel: <49> (89) 380 70 0, Fax: <49> (89) 929 30 11

Renesas Technology Hong Kong Ltd.
7/F., North Tower, World Finance Centre, Harbour City, Canton Road, Hong Kong
Tel: <852> 2265-6688, Fax: <852> 2375-6836

Renesas Technology Taiwan Co., Ltd.
FL 10, #99, Fu-Hsing N. Rd., Taipei, Taiwan
Tel: <886> (2) 2715-2888, Fax: <886> (2) 2713-2999

Renesas Technology (Shanghai) Co., Ltd.
26/F., Ruijin Building, No.205 Maoming Road (S), Shanghai 200020, China
Tel: <86> (21) 6472-1001, Fax: <86> (21) 6415-2952

Renesas Technology Singapore Pte. Ltd.
1, Harbour Front Avenue, #06-10, Keppel Bay Tower, Singapore 098632
Tel: <65> 6213-0200, Fax: <65> 6278-8001



H8S/2168Group Hardware Manual



Renesas Electronics Corporation

1753, Shimonumabe, Nakahara-ku, Kawasaki-shi, Kanagawa 211-8668 Japan

REJ09B0078-0300Z