

## Product Overview

### Multi-channel Silicon ESD Flow-Through Arrays

TE Connectivity's Silicon ESD arrays help to protect electronic circuits against damage from Electrostatic Discharge (ESD), surge and cable discharge events.

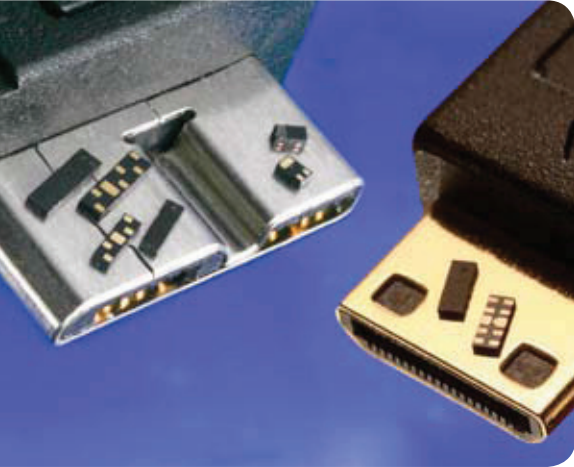



## KEY FEATURES

- Low Capacitance 0.20pF (typ, 200fF)
- Low leakage current - 50nA @ 5V (typ)
- Low clamping voltage - +9.20/-0.80V (typ) @ (tp=8x20µs, Ipp=2A)
- ESD - 20kV contact and air discharge per IEC61000-4-2
- Surge - 2A (tp=8x20µs) per IEC61000-4-5
- Small size and low profile XDFN Array packages - 0.31mm height

RoHS Complaint, Pb and Halogen Free (refers to: Br ≤ 900ppm, Cl ≤ 900ppm, Br+Cl ≤ 1500ppm)

The Silicon ESD (SESD) arrays help provide protection and improve reliability of electronics in applications including but not limited to consumer, portable and mobile electronics. The multi-channel SESD flow-through arrays have industry leading ultra-low capacitance of 0.20pF with low insertion loss which help protect high-speed data signals. The SESD arrays provide robust ESD protection with an industry-leading 20kV contact and air discharge rating per the IEC61000-4-2 standard. The ultra-low capacitance SESD arrays enable signal integrity for today's highest-speed interfaces including USB 3.0/2.0, HDMI, eSATA, DisplayPort, and Thunderbolt.

TE offers four- and six- channel miniature arrays which are up to 85% smaller than common multi-channel arrays to fit into space constrained applications. TE's ultra-small packages have lower parasitic impedance which reduces insertion loss at high frequencies compared to larger size packaged devices. The four- and six-channel arrays, with 0.31mm package height, have a 50% lower profile than other package options in the market. All of TE's SESD arrays are in flow-through design packages which allow for matched impedance PCB trace routing essential for high speed signal integrity.

## APPLICATIONS

- Consumer, mobile and portable electronics
- Tablet PC and external storage with high speed interfaces
- Ultra-high speed data lines
- USB 3.0/2.0, HDMI 1.3/1.4, DisplayPort interface, Thunderbolt interface (Light Peak), V-by-One HS, and LVDS interface
- Applications requiring high ESD performance in small DFN packages

## BENEFITS

- Industry-leading lowest capacitance; provides lowest insertion loss for high speed data signals
- Provides ESD protection up to 20kV contact and air discharge per IEC61000-4-2
- Industry's smallest footprint and lowest profile multi-channel ESD arrays helps to optimize board space
- Flow-through and single connection design helps routing PCB matched impedance high speed data lines
- Helps protect electronic circuits against damage from Electrostatic Discharge (ESD), lightning and cable discharge events
- Assist equipment to pass IEC61000-4-2, level 4 testing

DEVICE ELECTRICAL CHARACTERISTICS

Device Maximum Ratings

Multi-Channel Arrays	IEC 61000-4-2, level 4 (ESD withstand)		Temperature		Peak Current (tp=8x20µs)
	Contact (kV)	Air (kV)	Operating (°C)	Storage (°C)	Ipp (A)
SESD0402Q2UG-0020-090 (2-ch)	20	20	-55 to +125	-55 to +150	2.0
SESD0802Q4UG-0020-090 (4-ch)					
SESD1004Q4UG-0020-090 (4-ch)					
SESD1103Q6UG-0020-090 (6-ch)					

Caution: Stress exceeding Device Maximum Ratings may damage the device. Prolong exposure to stresses above the Recommended Operating Conditions may affect device reliability.

Device Electrical Characteristics @ T = 25°C

Multi-Channel Arrays	Input Capacitance <sup>(1)</sup>		Breakdown Voltage (typ)	Reverse Leakage Current (typ)	Clamping Voltage (typ)
	Typical (pF)	Maximun (pF)	V <sub>br</sub> @ I <sub>t</sub> = 1mA (V)	I <sub>L</sub> @ V <sub>RWM</sub> = 5.0V (nA)	V <sub>CL</sub> @ Ipp = 2.0A (V)
SESD0402Q2UG-0020-090 (2-ch)	0.20	0.22	+9.00 / -0.80	50.0	+9.20 / -0.80
SESD0802Q4UG-0020-090 (4-ch)					
SESD1004Q4UG-0020-090 (4-ch)					
SESD1103Q6UG-0020-090 (6-ch)					

<sup>(1)</sup> @ Vr = 0V, f = 3GHz, I/O to GND

DEVICE IV CHARACTERISTICS AND OPERATION

**SESD Multi-channel Array IV**

**One-channel in Multi-channel SESD Array**

- Helps protect against damage from V<sub>ESD</sub> strikes to 20kV contact & air discharge.
- If the signal voltage goes below -0.8V or above +9.0V the ESD device turns on and shunts to GND.

SESD MULTI-CHANNEL ARRAY SCHEMATIC AND PIN CONFIGURATION

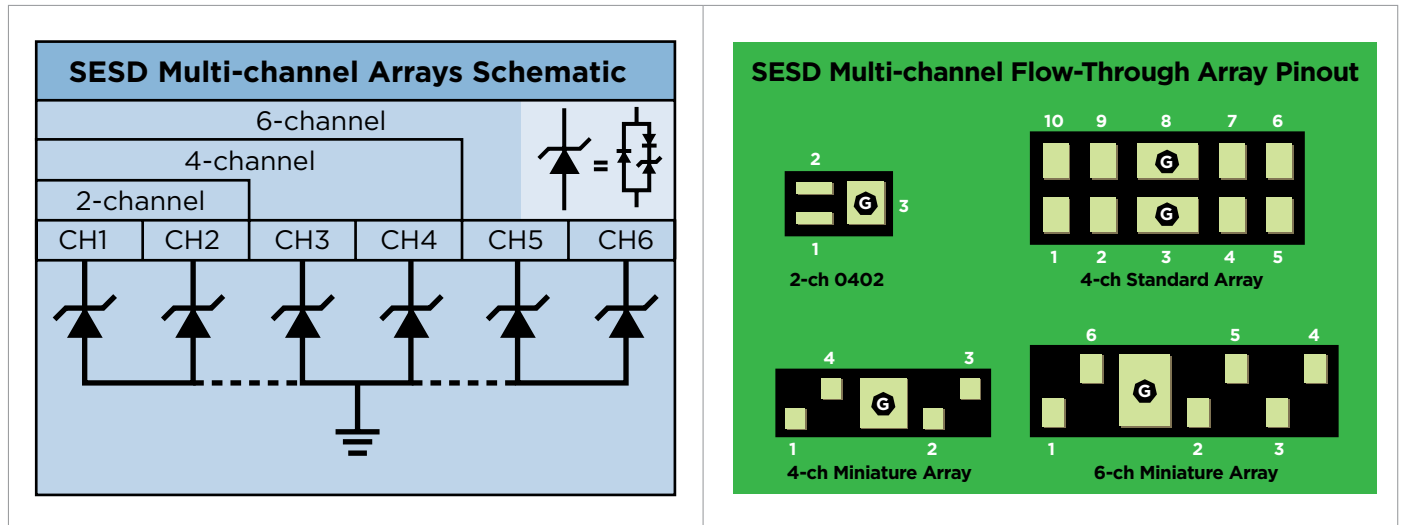

RECOMMENDED APPLICATION CONFIGURATIONS

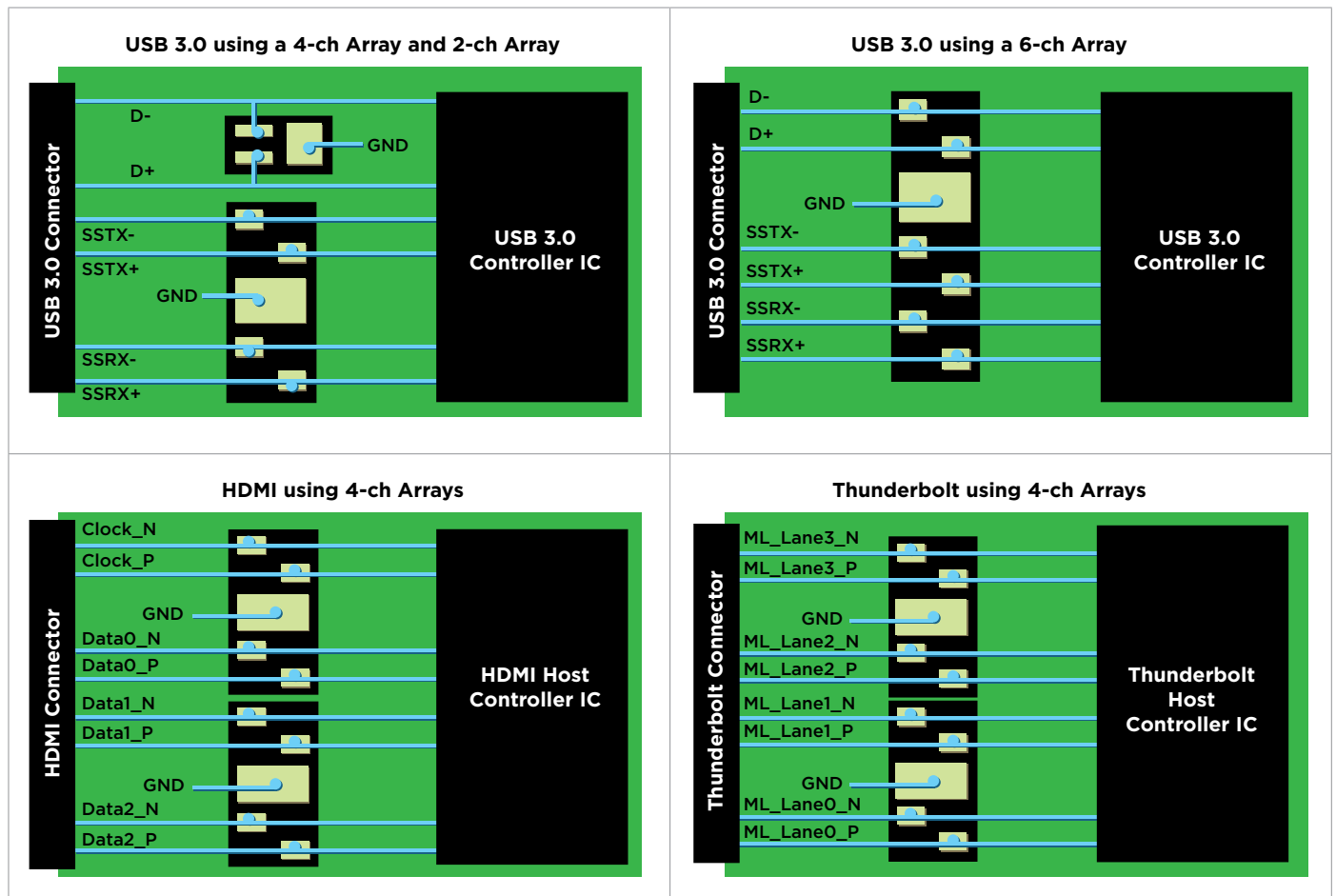

INSERTION LOSS DIAGRAMS

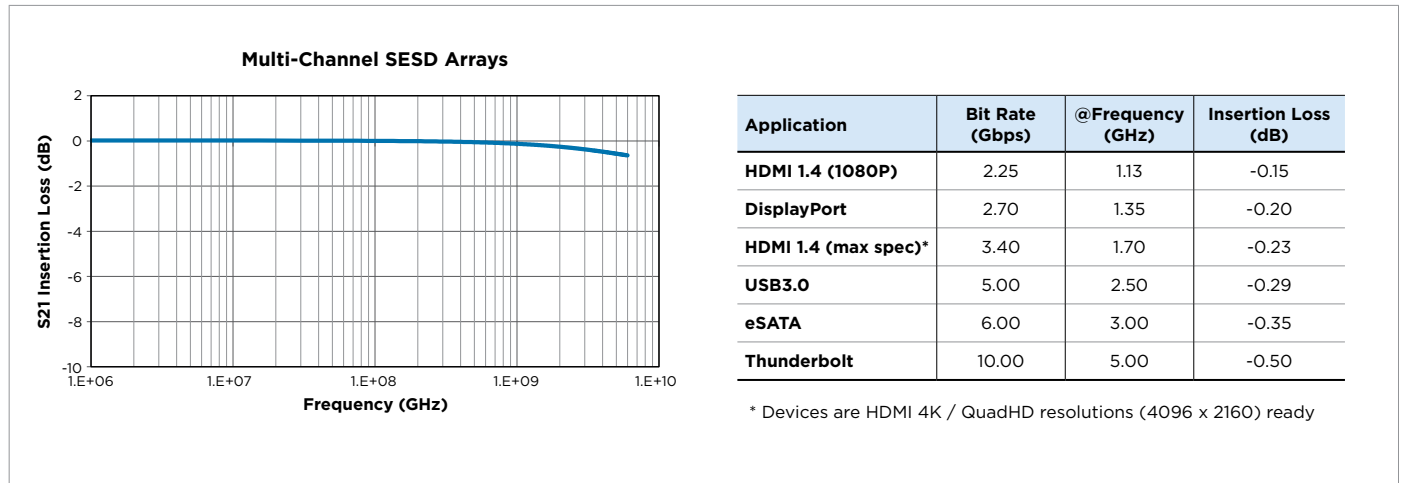

MATERIAL INFORMATION

RoHS Compliant

Directive 2000/53/EC  
Compliant

ELV Compliant

Directive 2002/95/EC  
Compliant

Halogen Free\*



Pb-Free



\* Halogen Free refers to: Br≤900ppm, Cl≤900ppm, Br+Cl≤1500ppm.  
 SESD devices meet MSL-1 Requirements  
 DFN case epoxy meets UL 94 V-0

EYE DIAGRAMS

**USB3.0 Eye Diagrams**  
5.0Gb/s, 1000mV differential, CPO Compliant Test Pattern

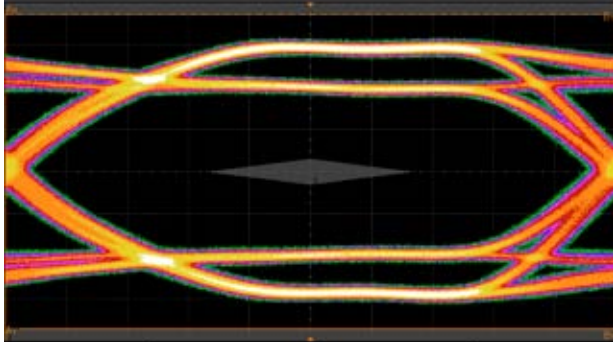

Without SESD Device

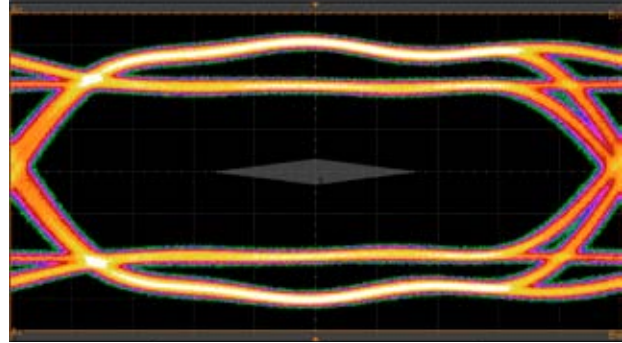

With SESD Device

**DisplayPort Eye Diagrams**  
2.7Gb/s, 800mV differential, PRBS7 Compliant Test Pattern, SSC enabled

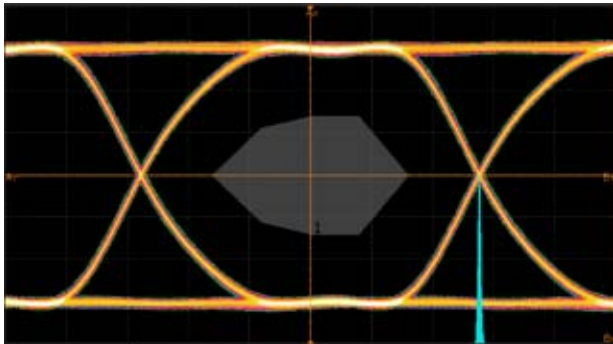

Without SESD Device

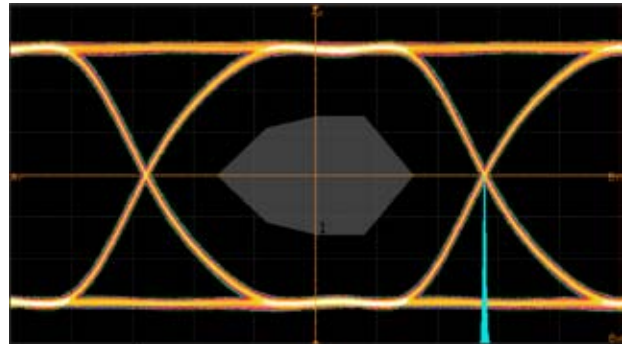

With SESD Device

**HDMI Eye Diagrams**  
3.4Gb/s, 990mV differential, TMDS Data

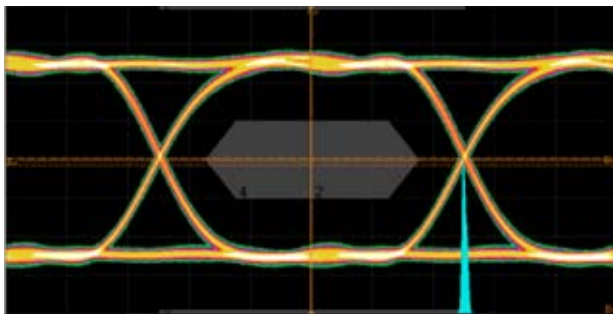

Without SESD Device

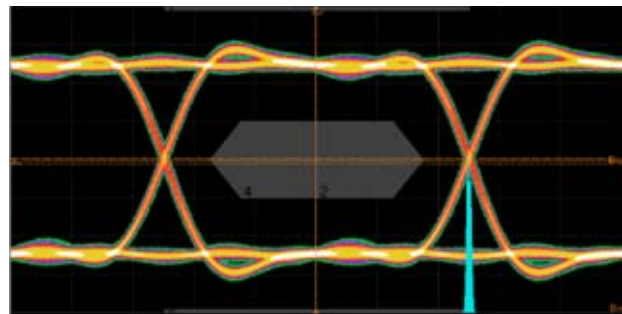

With SESD Device

DEVICE DIMENSION

SESD0402Q2UG-0020-090: 2-ch 0402 Size Array

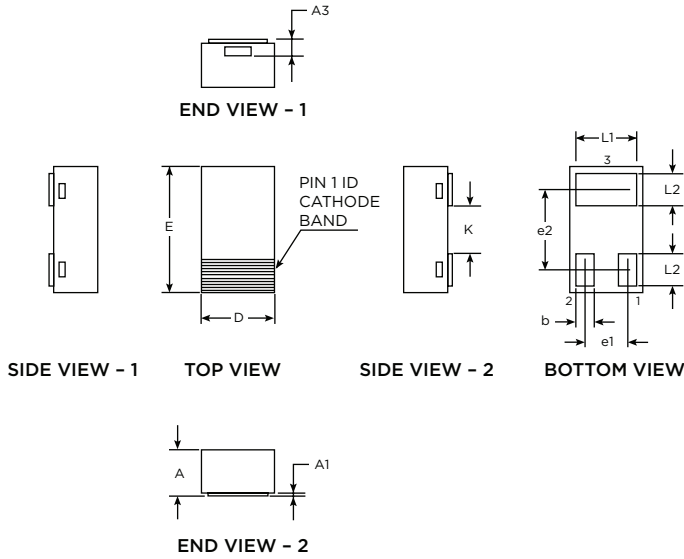

Dim	SESD0402Q2UG-0020-090					
	Millimeters			Inches		
	Min	Nom	Max	Min	Nom	Max
A	0.33	0.38	0.43	0.013	0.015	0.0169
A1	0	-	0.05	0	-	0.0020
A3	0.13 ref.			0.005 ref.		
D	0.55	0.60	0.65	0.022	0.024	0.026
E	0.95	1.00	1.05	0.037	0.039	0.041
K	0.35	0.40	0.45	0.014	0.016	0.018
L1	0.45	0.50	0.55	0.018	0.020	0.022
L2	0.20	0.25	0.30	0.008	0.010	0.012
b	0.10	0.15	0.20	0.004	0.006	0.008
e1	0.35 BSC			0.014 BSC		
e2	0.65 BSC			0.026 BSC		

BSC - Basic Spacing between Centers

SESD1004Q4UG-0020-090: 4-ch Flow-Through Standard Array

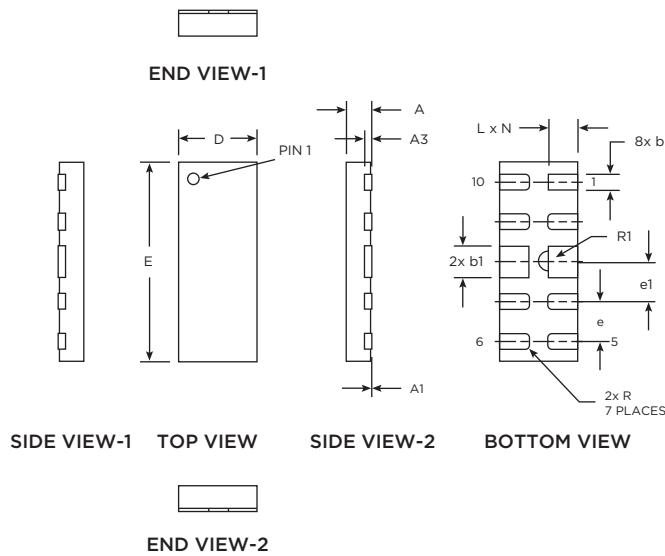

Dim	SESD1004Q4UG-0020-090					
	Millimeters			Inches		
	Min	Nom	Max	Min	Nom	Max
A	0.30	0.31	0.32	0.0118	0.0122	0.0126
A1	0	-	0.05	0	-	0.0020
A3	0.10 ref.			0.004 ref.		
D	0.90	1.00	1.10	0.035	0.039	0.043
E	2.40	2.50	2.60	0.094	0.098	0.102
b	0.15	0.20	0.25	0.006	0.008	0.010
b1	0.35	0.40	0.45	0.014	0.016	0.018
L	0.30	0.38	0.425	0.012	0.015	0.017
e	0.50 BSC			0.020 BSC		
e1	0.60 BSC			0.024 BSC		
N	10			10		
R	0.075 BSC			0.003 BSC		
R1	0.125 BSC			0.005 BSC		

BSC - Basic Spacing between Centers

\* Pin 1 dot is laser marked. Radius and location within the pin 1 terminal.



DEVICE DIMENSION

CONT'D

**SESD0802Q4UG-0020-090: 4-ch Flow-Through Miniature Array**

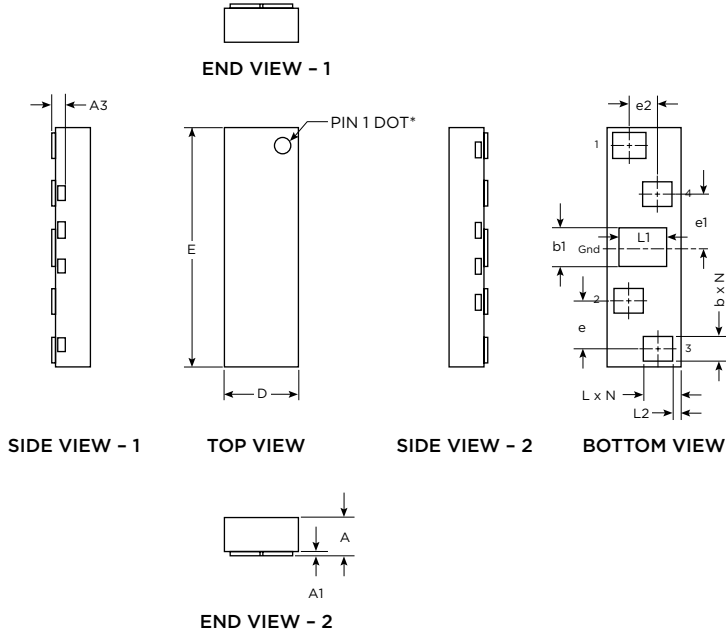

Dim	SESD0802Q4UG-0020-090					
	Millimeters			Inches		
	Min	Nom	Max	Min	Nom	Max
A	0.30	0.31	0.32	0.0118	0.0122	0.0126
A1	0	-	0.05	0	-	0.0020
A3	0.10 ref.			0.004 ref.		
D	0.50	0.60	0.70	0.020	0.024	0.028
E	1.90	2.00	2.10	0.075	0.079	0.083
b	0.15	0.20	0.25	0.006	0.008	0.010
b1	0.25	0.30	0.36	0.010	0.012	0.014
L	0.25	0.30	0.35	0.010	0.012	0.014
L1	0.35	0.40	0.45	0.014	0.016	0.018
L2	0.05 BSC			0.002 BSC		
e	0.40 BSC			0.016 BSC		
e1	0.45 BSC			0.018 BSC		
e2	0.25 BSC			0.010 BSC		
N	4			4		

BSC - Basic Spacing between Centers

**SESD1103Q6UG-0020-090: 6-ch Flow-Through Miniature Array**

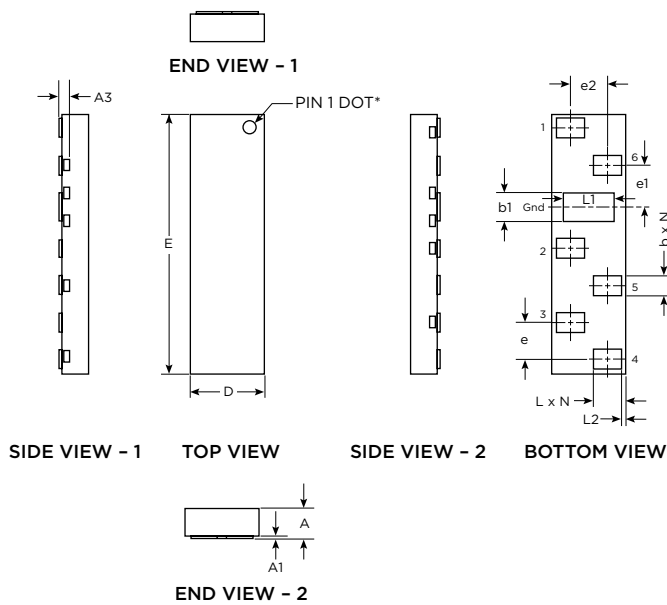

Dim	SESD1103Q6UG-0020-090					
	Millimeters			Inches		
	Min	Nom	Max	Min	Nom	Max
A	0.30	0.31	0.32	0.0118	0.0122	0.0126
A1	0	-	0.05	0	-	0.0020
A3	0.10 ref.			0.004 ref.		
D	0.70	0.80	0.90	0.027	0.031	0.035
E	2.70	2.80	2.90	0.106	0.110	0.114
b	0.15	0.20	0.25	0.006	0.008	0.010
b1	0.25	0.30	0.35	0.010	0.012	0.014
L	0.30	0.35	0.40	0.012	0.014	0.016
L1	0.50	0.55	0.60	0.019	0.021	0.023
L2	0.05 BSC			0.002 BSC		
e	0.40 BSC			0.016 BSC		
e1	0.45 BSC			0.018 BSC		
e2	0.40 BSC			0.016 BSC		
N	6			6		

BSC - Basic Spacing between Centers

\* Pin 1 dot is laser marked. Radius and location within the pin 1 terminal.



RECOMMENDED LANDING PAD LAYOUT

SESD0402Q2UG-0020-090: 2-ch 0402 Size Array

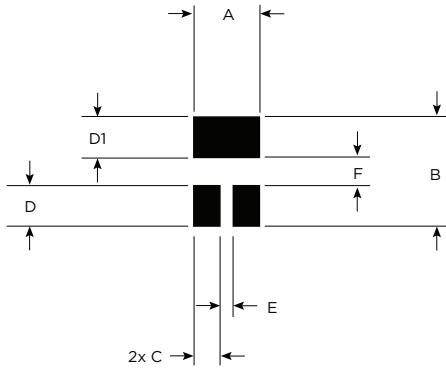

SESD Landing Pad Layout 3 Pin 2-ch 0402 Size Array		
Symbol	Millimeters	Inches
A	0.60	0.024
B	1.00	0.039
C	0.225	0.009
D	0.35	0.014
D1	0.35	0.014
E	0.15	0.006
F	0.30	0.012

SESD1004Q4UG-0020-090: 4-ch Flow-Through Standard Array

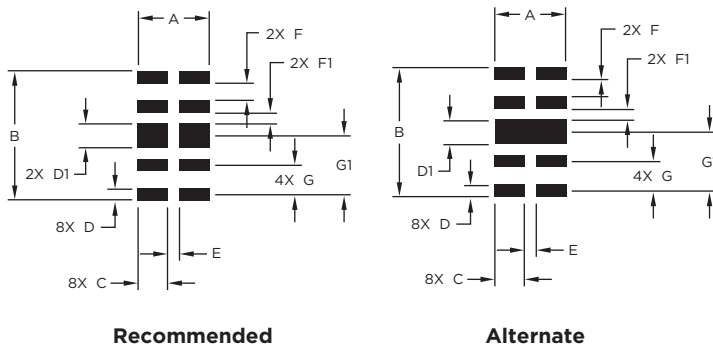

SESD Landing Pad Layout 10 Pin 4-ch Standard FT Array		
Symbol	Millimeters	Inches
A	1.20	0.047
B	2.20	0.087
C	0.50	0.020
D	0.20	0.008
D1	0.40	0.016
E	0.20	0.008
F	0.30	0.012
F1	0.20	0.008
G	0.50 BSC	0.020 BSC
G1	1.00 BSC	0.039 BSC

BSC - Basic Spacing between Centers

RECOMMENDED LANDING PAD LAYOUT

CONT'D

SESD0802Q4UG-0020-090: 4-ch Flow-Through Miniature Array

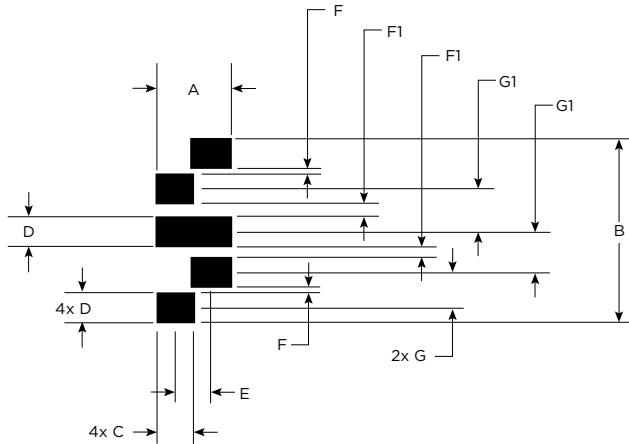

SESD Landing Pad Layout 5 Pin 4-ch Miniature FT Array		
Symbol	Millimeters	Inches
A	0.60	0.024
B	2.00	0.079
C	0.30	0.012
D	0.30	0.012
E	0.30	0.012
F	0.10	0.004
F1	0.15	0.006
G	0.40 BSC	0.016 BSC
G1	0.45 BSC	0.018 BSC

BSC - Basic Spacing between Centers

SESD1103Q6UG-0020-090: 6-ch Flow-Through Miniature Array

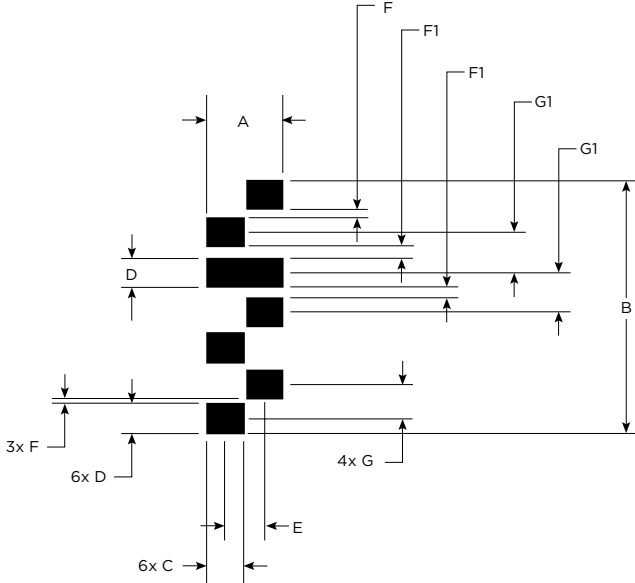

SESD Landing Pad Layout 7 Pin 6-ch Miniature FT Array		
Symbol	Millimeters	Inches
A	0.80	0.031
B	2.80	0.110
C	0.35	0.014
D	0.30	0.012
E	0.45	0.018
F	0.10	0.004
F1	0.15	0.006
G	0.40 BSC	0.016 BSC
G1	0.40 BSC	0.016 BSC

BSC - Basic Spacing between Centers

## FOR MORE INFORMATION

### TE Circuit Protection

308 Constitution Drive  
Menlo Park, CA USA 94025-1164  
Tel : (800) 227-7040, (650) 361-6900  
Fax : (650) 361-4600

[www.circuitprotection.com](http://www.circuitprotection.com)  
[www.circuitprotection.com.hk](http://www.circuitprotection.com.hk) (Chinese)  
[www.te.com/japan/bu/circuitprotection/](http://www.te.com/japan/bu/circuitprotection/) (Japanese)

#### Brazil

Tel : 55-11-2103-6090  
Fax: 55-11-2103-6216

#### UK / Eire / Benelux / Israel

**South Africa / Nordic / Baltic / Others**  
Tel : 49-89-6089485  
Fax: 49-89-6089394

#### Germany / Austria / Switzerland / Eastern Europe / Russia

Tel : 49-89-6089584  
Fax: 49-89-6089394

#### France / Italy / Iberia / Greece / Turkey

Tel : 33-1-34208455  
Fax: 33-1-34208479

#### Japan

Tel : 81-44-900-5110  
Fax: 81-44-900-5140

#### Korea

Tel : 82-2-3415-4654  
Fax: 82-2-3486-1786

#### Taiwan

Tel : 886-2-8768-2788 x 211  
Fax: 886-2-8768-1277

#### China, Hong Kong

Tel : 852-2738-8181  
Fax: 852-2735-1185

#### China, Beijing

Tel : 86-10-6569-3488 x 16526  
Fax: 86-10-6569-3206

#### China, Shanghai

Tel : 86-21-6106-7379  
Fax: 86-21-6485-3255

#### China, Shenzhen / Guangzhou

Tel : 86-755-2515-4797  
Fax: 86-755-2598-0419

#### Singapore / Indonesia

Tel : 65-6590-5089  
Fax: 65-6481-9377

#### Thailand / Malaysia / Vietnam

Tel : 6-04-217-8112  
Fax: 6-04-229-8177

#### Australia / Philippines

Tel : 63-2-988-9465  
Fax: 63-2-848-0205

#### India

Tel : 91-80-4161-3745  
Mobile : 91-99-0248-8886

Part numbers in this brochure are RoHS Compliant\*, unless marked otherwise.  
\*as defined [www.te.com/leadfree](http://www.te.com/leadfree)

**te.com**

© 2012 Tyco Electronics Corporation, a TE Connectivity Ltd. Company. All Rights Reserved.  
RCPO107E 02/2012

TE Connectivity and TE connectivity (logo) are trademarks. Other logos, product and/or company names might be trademarks of their respective owners.

All information, including illustrations, is believed to be accurate and reliable. Users, however, should independently evaluate the suitability of and test each product selected for their application. Tyco Electronics Corporation and/or its Affiliates in the TE Connectivity Ltd. family of companies ("TE") makes no warranties as to the accuracy or completeness of the information, and disclaims any liability regarding its use. TE only obligations are those in the TE Standard Terms and Conditions of Sale and in no case will TE be liable for any incidental, indirect, or consequential damages arising from the sale, resale, use, or misuse of its products. Specifications are subject to change without notice. In addition, TE reserves the right to make changes to materials or processing that do not affect compliance with any applicable specification without notification to Buyer. Without expressed or written consent by an officer of TE, TE does not authorize the use of any of its products as components in nuclear facility applications, aerospace, or in critical life support devices or systems.

