

Specification Status: Released

Electrical Rating

Voltage: 16V_{DC} MAX
Current: 100A MAX

Insulating Material:
Cured, Flame Retardant Epoxy Polymer
meets UL94 V-0 Requirements

Lead Material:
20 AWG Tin Plated Copper
(0.8 mm [0.032] nom. diameter)

Marking:

 Manufacturer's Mark
and Voltage

HF5.5 — Part Identification

— Lot Identification
(can be on back)

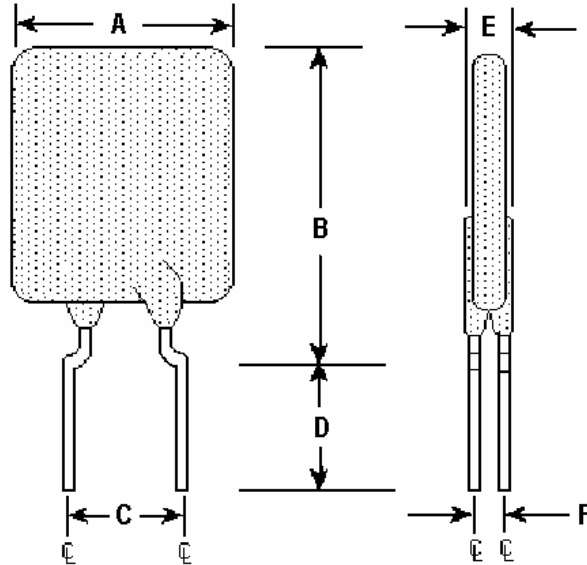

TABLE I. DIMENSIONS:

	A		B		C		D		E		F
	MIN	MAX	MIN	MAX	MIN	MAX	MIN	MAX	MIN	MAX	TYP
mm:	--	11.2	--	18.9	4.3	5.8	7.6	--	--	3.0	1.2
in*:	--	(0.44)	--	(0.74)	(0.17)	(0.23)	(0.3)	--	--	(0.12)	(0.05)

*Rounded off approximation

TABLE II. PERFORMANCE RATINGS:

CURRENT RATINGS		TIME TO TRIP	INITIAL RESISTANCE VALUES		R _a MAX	TRIPPED-STATE POWER DISSIPATION
AMPS AT 25°C HOLD	AMPS AT 25°C TRIP	SECONDS AT 25°C, 27.5A MAX	OHMS AT 25°C MIN	OHMS AT 25°C MAX	OHMS AT 25°C MAX	WATTS AT 25°C 16V TYP
5.5	10.0	6.0	0.013	0.025	0.037	3.5

Reference Documents:

PS400, PS300 (reference for R₁ MAX)

Precedence:

This specification takes precedence over documents referenced herein.

Effectivity:

Reference documents shall be the issue in effect on the date of invitation for bid.

CAUTION:

Operation beyond the rated voltage or current may result in rupture, electrical arcing or flame.

Materials Information

ROHS Compliant

ELV Compliant

Pb-Free





308 Constitution Drive
Menlo Park, CA 94025-1164
Phone: 800-227-4856
www.circuitprotection.com

PolySwitch®
PTC Devices
Overcurrent Protection Device
Raychem Circuit Protection Products

PRODUCT: AHRF550

DOCUMENT: SCD 26636
PCN: RF0206
REV LETTER: D
REV DATE: MARCH 27, 2009
PAGE NO.: 2 OF 2

TABLE III. AUTOMOTIVE SPECIFIC STRESS TESTS AND TEST CONDITIONS:

ELECTRICAL STRESS TESTS	TEST CONDITIONS (see note 2)
ESD Voltage Withstand (see note 1)	25kV
Short Circuit Fault Current Durability	25 cycles, 16V, 200A
Fault Current Durability	350 cycles, 16V/100A
End-of-life Mode Verification	1750 cycles, 16V/100A
Jump Start Endurance (see note 1)	3 cycles, 26V, 1 minute duration
Load Dump Endurance (see note 1)	10 cycles, 86.5V

Note 1: The PolySwitch devices are tested in series with a load resistance and the voltages specified in the test conditions are shared between the PolySwitch device and the load resistance as specified in PS400.

Note 2: Please refer to Appendix A of PS400 for the detailed test procedures.